

Since 1915 —

Manufacturers of Electronic  
Apparatus for Science  
and Industry



CATALOG **Q**

# GENERAL RADIO COMPANY

WEST CONCORD • MASSACHUSETTS • USA



File Courtesy of GRWiki.org

# GENERAL RADIO COMPANY

## Main Office and Factory

West Concord, Massachusetts  
Telephone: (Concord) EMerson 9-4400  
(Boston) MIssion 6-7400  
Cable Address: GENRADCO, BOSTON

## DISTRICT OFFICES

General Radio sales engineering offices are maintained in the following cities. These offices are staffed by competent factory-trained engineers. We invite your inquiries for technical, commercial and service information.

Office	Telephone	Staff
<b>NEW YORK</b> Broad Avenue at Linden, Ridgefield, New Jersey	(N. Y.) WOrth 4-2722 (N. J.) WHitney 3-3140	George G. Ross, <i>Manager</i> Leo J. Chamberlain Peter Bishop Edward F. Sutherland
<b>PHILADELPHIA</b> 1150 York Road, Abington, Pa	HAncock 4-7419	Kipling Adams, <i>Manager</i> John E. Snook
<b>WASHINGTON AND BALTIMORE</b> 8055 13th Street, Silver Spring, Maryland	JUniper 5-1088	C. William Harrison, <i>Manager</i> John C. Held Frank J. Finnegan
<b>CHICAGO</b> 6605 West North Avenue, Oak Park, Illinois	Village 8-9400	William M. Ihde, <i>Manager</i> L. C. (Tom) Fricke Robert P. Delzell Lane W. Gorton
<b>SAN FRANCISCO</b> 1186 Los Altos Avenue, Los Altos, California	Whitecliff 8-8233	James G. Hussey, <i>Manager</i> Donald M. Vogelhaar
<b>LOS ANGELES</b> 1000 North Seward Street, Los Angeles 38, California	HOLlywood 9-6201	Joseph E. Belcher, <i>Manager</i> Frank J. Thoma Kenneth J. Castle John R. Ross
<b>CANADA</b> 99 Floral Parkway, Toronto 15, Ontario	CHerry 6-2171	Arthur Kingsnorth, <i>Manager</i> Richard J. Provan

## REPAIR SERVICES

### East Coast

General Radio Company  
Service Department  
West Concord, Massachusetts  
Telephone: (Concord) EMerson 9-4400  
(Boston) MIssion 6-7400

### New York

General Radio Company  
Service Department  
Broad Avenue at Linden  
Ridgefield, New Jersey  
Telephone: (N. Y.) WOrth 4-2722  
(N. J.) WHitney 3-3140

### Midwest

General Radio Company  
Service Department  
6605 West North Avenue  
Oak Park, Illinois  
Telephone: Village 8-9400

### West Coast

General Radio Company  
Service Department  
1000 North Seward Street  
Los Angeles 38, California  
Telephone: HOLlywood 9-6201

### Canada

Bayly Engineering, Ltd.  
First Street  
Ajax, Ontario  
Telephone: EMpire 2-3741

## EXPORT REPRESENTATIVES

For a list of representatives in other countries, see inside back cover



SINCE 1915

*manufacturers of electronic apparatus for  
science and industry*



CATALOG

Q

MAY 1961

GENERAL RADIO COMPANY

WEST CONCORD, MASSACHUSETTS

NEW YORK • PHILADELPHIA • WASHINGTON  
CHICAGO • LOS ANGELES • SAN FRANCISCO • TORONTO

Copyright, 1961, by General Radio Company, W. Concord, Mass., U.S.A.



# TABLE OF CONTENTS

	Page		Page
<b>WE SELL DIRECT</b> . . . . .	iv	Audio-Frequency . . . . .	60-61
<b>WARRANTY</b> . . . . .	v	Radio-Frequency . . . . .	61
<b>HOW TO ORDER</b> . . . . .	vi, vii	Power Amplifier . . . . .	63
<b>PATENTS</b> . . . . .	viii	Unit Amplifier (Audio) . . . . .	64
<b>BRIDGES AND IMPEDANCE-</b>		<b>FREQUENCY STANDARDS AND METERS 65-84</b>	
<b>MEASURING INSTRUMENTS</b> . . . . .	1-37	5-Mc Standard . . . . .	68
DC Resistance Bridges . . . . .	6-9	1000-Mc Standard . . . . .	68
Power-Frequency Bridges . . . . .	10-12	Frequency Multipliers . . . . .	72
Audio-Frequency Bridges . . . . .	13-29	Heterodyne Interpolation System . . . . .	74
Capacitance Bridges . . . . .	13-19	Digital Time and Frequency Meter . . . . .	75
Dielectric Sample Holder . . . . .	17	Time/Frequency Calibrator . . . . .	82
Inductance Bridges . . . . .	20	Frequency Meter and Discriminator . . . . .	83
Impedance Bridges . . . . .	22-27	<b>GENERATORS</b> . . . . .	<b>85-124</b>
Vacuum-Tube and Transistor Bridge . . . . .	28	Standard-Signal Generators . . . . .	85-93
Radio-Frequency Bridges . . . . .	30-33	5 kc to 50 Mc . . . . .	86
VHF-UHF Bridges . . . . .	34-37	16 kc to 50 Mc . . . . .	88
Admittance Meter . . . . .	34	40 to 250 Mc . . . . .	90
Transfer-Function and Imittance Bridge . . . . .	36	50 to 920 Mc . . . . .	90
<b>COAXIAL INSTRUMENTS AND</b>		<b>SIGNAL GENERATOR ACCESSORIES</b> . . . . .	92
<b>COMPONENTS</b> . . . . .	<b>38-57</b>	Output Devices . . . . .	92
Index . . . . .	39	Modulators . . . . .	93
Coaxial Connectors . . . . .	38, 40	<b>OSCILLATORS</b> . . . . .	<b>94-113</b>
Installation Tools . . . . .	41	Low-Frequency, 0.01 to 1000 cps . . . . .	96
Adaptors to UG and Other Connectors . . . . .	42	Audio-Frequency, 10 to 100,000 cps . . . . .	98-103
Coupling Elements . . . . .	43	Audio-Video Frequency, 20 cps to 12 Mc . . . . .	104
Patch Cords . . . . .	44	Radio Frequency, 0.5 to 50 Mc . . . . .	107, 108
Filters . . . . .	45	VHF-UHF, 50 to 2000 Mc . . . . .	109-112
Mixer . . . . .	45	Microwave, 2000-7400 Mc . . . . .	113
Air Lines . . . . .	46	<b>PULSE AND TIME-DELAY GENERATORS</b> . . . . .	114-122
Line Stretchers . . . . .	46	Unit Pulser . . . . .	115
Terminations . . . . .	47	Pulse, Sweep, and Time-Delay Generator . . . . .	116
Attenuators . . . . .	48	Pulse Amplifier . . . . .	119
Stubs and Tuning Elements . . . . .	49	Time-Delay Generator . . . . .	120
Voltmeters . . . . .	50	Delay Line . . . . .	122
Balun . . . . .	51	<b>RANDOM-NOISE GENERATOR</b> . . . . .	123
Slotted Line . . . . .	52	<b>METERS</b> . . . . .	<b>125-132</b>
Smith Charts . . . . .	55	VACUUM-TUBE VOLTMETER . . . . .	126
<b>DETECTORS AND AMPLIFIERS</b> . . . . .	<b>56-64</b>	ELECTROMETER (AND DC AMPLIFIER) . . . . .	128
Null Detectors . . . . .	58-62	MEGOHMMETER . . . . .	130
UHF-VHF . . . . .	58		

	Page		Page
AUDIO-FREQUENCY MICROVOLTAGE . . . . .	131	Sound-Level Calibrator . . . . .	187
MODULATION MONITOR . . . . .	132	Impact Noise Analyzer . . . . .	188
OUTPUT POWER METERS . . . . .	134	SOUND AND VIBRATION ANALYZER . . . . .	189
<b>POWER SUPPLIES . . . . . 136-140</b>		OCTAVE-BAND ANALYZER . . . . .	191
ADJUSTABLE REGULATED POWER SUPPLY . . . . .	136	VIBRATION METER . . . . .	192
UNIT POWER SUPPLY . . . . .	137	VIBRATION CALIBRATOR . . . . .	194
UNIT REGULATED POWER SUPPLY . . . . .	137	<b>STROBOSCOPES . . . . . 195-198</b>	
Power Pack . . . . .	137	STROBOTAC® ELECTRONIC STROBOSCOPE	196
Amplitude-Regulating Power Supply . . . . .	138	STROBOLUM HIGH INTENSITY LIGHTSOURCE	197
Modulating Power Supply . . . . .	139	CONTACTOR . . . . .	198
<b>RECORDERS AND SWEEP DRIVES . 141-146</b>		<b>VARIAC® ADJUSTABLE AUTO-</b>	
Graphic Level Recorder . . . . .	142	<b>TRANSFORMERS . . . . . 199-217</b>	
Sweep Drive . . . . .	144	50- TO 60-CYCLE MODELS . . . . .	201-209
Dial Drives . . . . .	146	350- TO 1200-CYCLE MODELS . . . . .	210
<b>R-L-C STANDARDS AND DECADES. 147-178</b>		MOTOR DRIVEN MODELS . . . . .	212
RESISTORS . . . . .	147-155	REMOTE CONTROL . . . . .	216
Decade Resistance Boxes . . . . .	149	METERED VARIAC® AUTO-	
Decade Resistance Units . . . . .	151	TRANSFORMERS . . . . .	217
Decade Attenuators . . . . .	153	<b>VOLTAGE REGULATORS . . . . . 218-220</b>	
Decade Voltage Dividers . . . . .	154	COMMERCIAL TYPES . . . . .	218
Fixed Resistors . . . . .	155	MILITARIZED TYPES . . . . .	220
CAPACITORS . . . . .	156-171	<b>VARIAC® MOTOR SPEED CONTROLS 221-223</b>	
Precision Variable Standards . . . . .	158	<b>WAVEFORM-MEASURING</b>	
Fixed Air Standards . . . . .	161, 162	<b>INSTRUMENTS . . . . . 224-228</b>	
Fixed Mica Standards . . . . .	163	WAVE ANALYZER . . . . .	225
Precision Decade Capacitors . . . . .	164	DISTORTION AND NOISE METER . . . . .	227
Decade Capacitor Units . . . . .	166	A-M Detector Unit . . . . .	228
Mica and Paper Decade Boxes . . . . .	168	<b>PARTS AND ACCESSORIES . . . . . 229-241</b>	
Polystyrene Decade Boxes . . . . .	168	VARIABLE AIR CAPACITORS . . . . .	230
Fixed Mica Capacitors . . . . .	170	POTENTIOMETERS . . . . .	231
Fuel-Gage Calibrator . . . . .	171	DIALS . . . . .	234
INDUCTORS . . . . .	172-178	KNOBS . . . . .	236
Standard Inductors—Air Core . . . . .	173	TRANSFORMERS . . . . .	237
Variable Inductors . . . . .	175	BINDING POSTS . . . . .	238
Inductors—Ferromagnetic Core . . . . .	176	ALLIGATOR CLIPS . . . . .	238
Decade Inductance Boxes . . . . .	177	PLUGS AND JACKS (BANANA PLUGS) . . . . .	240
Decade Inductor Units . . . . .	178	PATCH CORDS . . . . .	241
<b>SOUND AND VIBRATION MEASURING</b>		POWER CORDS . . . . .	241
<b>INSTRUMENTS . . . . . 179-194</b>		ADAPTORS—BANANA PLUG TO COAX . . . . .	241
SOUND-SURVEY METER . . . . .	181	<b>CABINETS . . . . . 242</b>	
SOUND-LEVEL METER . . . . .	182	<b>REACTANCE CHARTS . . . . . 244</b>	
CONDENSER MICROPHONE SYSTEM . . . . .	184	<b>DECIBEL TABLES . . . . . 245</b>	
SOUND-LEVEL METER ACCESSORIES . . . . .	185	<b>INDEX BY TYPE NUMBER . . . . . 251</b>	
Vibration Pickup . . . . .	185	<b>INDEX BY TITLE OR FUNCTION . . . . . 254</b>	
Dynamic Microphone . . . . .	186		

# WE SELL DIRECT . . .

To develop the type of product manufactured by the General Radio Company requires a large staff of engineers, each a specialist in one or more branches of electronic engineering and science.

There has always been close contact between our Company and our customers, many of whom are themselves engineers and scientists. To maintain and to further this contact is the responsibility of our staff of sales engineers. This group has the principal function of working directly with the customer for the best selection of instruments for the job with the minimum expenditure. The advice of our development engineering staff is available for expert consultation when the need arises.



View of General Radio plant in West Concord, Massachusetts.

Because of the technical nature and diverse uses of our equipment we feel that a direct method of marketing is the most efficient and useful to the buyer. Consequently, the General Radio Company sells its products directly to the user in the United States and Canada, with no intermediary distributing organization, on a net, no discount basis. The buyer is thus assured of receiving the lowest possible price less all resale discounts and commissions and one that he can immediately find by consulting a current price list. We have always felt that price is as much a part of specifications as is a technical description.

In major marketing areas of the United States and in Toronto the Company maintains district sales offices, which are staffed by skilled factory-trained engineers who are in a position to speak directly for the factory, and who are conveniently available for consultation on all technical and commercial questions. The locations of these offices are given in the inside front cover of this catalog.

In order that customers outside the United States may receive equivalent technical service, exclusive representatives have been appointed in most countries abroad, each capable of giving technical, commercial, and service information regarding General Radio products. For a list of export representatives, see the inside back cover of this catalog. In all matters regarding General Radio apparatus, the customer should communicate with the appropriate representative. Prices listed in the catalog are for domestic use only. Costs in countries abroad, where import duty, freight, and taxes must be added, may be obtained from the representatives in those countries.

# THE HALLMARK OF QUALITY



Quality is traditional in products that bear the GR label. General Radio instruments are quality instruments, built from quality components to give reliable service and to maintain their accuracy over a long and useful life.

This Company's earliest products were laboratory standards, and General Radio today still supplies the standards of inductance, capacitance, and frequency that are basic to the electronics industry. The successful manufacture of standards is predicated on quality, both in design and in production. This tradition of quality is evidenced throughout the GR line. GR instruments are designed and built to exacting specifications, to be accurate, rugged and reliable. Many a laboratory has GR products built several decades ago which are still giving satisfactory service.

Performance specifications are an important yardstick for quality. General Radio specifications are conservative and honest. Each instrument is calibrated to tolerances at least 25% tighter than those published. Performance to these specifications is guaranteed for two years. General Radio is the first instrument manufacturer to make this guarantee on its entire line of products.

Although these specifications attest the accuracy, range, and versatility of GR products, they cannot disclose all the attention to detail in design, manufacture, sales and service that helps to maintain General Radio's reputation for reliable instruments.

## DESIGN

New circuits, new components, new designs, new techniques — these form the basis of new General Radio instruments. General Radio development engineers have a wide variety of background and experience in the United States and abroad. The advice of this engi-

neering staff is available to General Radio customers in the solution of their measurement problems.

## MANUFACTURE

Quality is also evident in details of construction; externally in the sturdy, aluminum panels, dials with low-reflection background and carefully designed scales, quality knobs, well thought out panel layout and markings, attractive finish, and instrument-grade hardware.

Inside the instruments are precision components, many of them made by General Radio, reliable etched circuits, rugged nonmagnetic chassis, and cables with braided covering.

All these parts and components as well as design practices are controlled by a comprehensive standards program, which keeps the number of different pieces, tools and procedures to an economic minimum, thereby making possible high quality at moderate prices. The standards program also includes constant study and testing to evaluate and to maintain quality. The manufacture of the products is carried out by skilled workmen aided by the most modern machinery, and quality is further assured by frequent stages of inspection.

## SALES

Supporting and extending the quality that runs through General Radio design and manufacturing processes are the policies and operations of the Sales Engineering Department, which are summarized on the preceding page — WE SELL DIRECT. The GR sales engineer is responsible not only to his company, but also to the customer. His job is not only to sell GR products, but also to be sure that the customer buys the instrument best suited to his needs.

## SERVICE

General Radio service laboratories are located in several of our District Offices and at the main plant in West Concord. They can furnish prompt, efficient, and satisfactory service when needed.

## PUBLICATIONS

A monthly publication, *The General Radio Experimenter*, describes new developments, as well as general technical information. Sent free upon request, the magazine is distributed to more than 100,000 readers located in the United States and 83 other countries.

### Two-Year Warranty

We warrant that each new instrument sold by us is free from defects in material and workmanship and that properly used it will perform so long according with applicable specifications for a period of two years after original shipment. Any instrument or component that is found within the two-year period not to meet these standards, after examination by our factory, district office, or authorized repair agency personnel will be repaired or, at our option, replaced without charge, except for tubes or batteries that have given normal service.

GENERAL RADIO COMPANY  
WEST CONCORD, MASSACHUSETTS

The instrument and program are guaranteed.

*True*

Guarantee indicated on specifications are based on the National Bureau of Standards.

This warranty tag accompanies all General Radio instruments.



# HOW TO ORDER

## ORDER BY TYPE NUMBER

Always order by catalog type number, and, whenever possible, mention name of item, ranges, or other significant specifications as protection against misunderstanding.

Be sure to include orders for any accessories desired or for calibrations that must be made before shipment. When minor modifications are desired to adapt the equipment to the customer's purposes, our Sales Engineering Department will be glad to discuss the details.

For EXPORT ORDERS please state the desired line-voltage and frequency. For example: 230 volts/50 cps; 115 volts/50 cps.

## TELEGRAPH AND CABLE ORDERS

We have direct teleprinter connections with both Western Union and Bell System TWX for prompt handling of messages. Our TWX call letters are CONC MASS 972.

Use the code words accompanying each catalog description. Our cable address is GENRADCO CONCORD (MASS).

## ADDRESS

All communications, except when otherwise advised, should be sent to General Radio Company, West Concord, Massachusetts, to one of our district offices (see inside front cover), or to the appropriate export representative.

## PACKING

There is no charge for our domestic packing or regular export packing and no charge for shipping containers or cases. Cases are not returnable.

## SHIPPING INSTRUCTIONS

Unless specific instructions accompany the order, we shall use our judgment as to the best method of shipment. Repair parts or other items needed quickly will be shipped by air if requested. The following table shows approximate cost of four different methods of shipment to major cities in the United States, door-to-door.

Export shipments via air freight save transport time and in most cases transport costs. For example, the estimated charges, factory to Milan, Italy, for 100 pounds net weight of instruments (shipping weight 150 pounds by air, 219 pounds by ocean freight) are \$63.20 for air freight and \$101.50 for ocean carrier via New York. Air shipping weight and ocean shipping weight are approximately 50 and 100 percent more, respectively, than the net weight.

## TERMS

All prices are FOB West Concord, Massachusetts.

## MINIMUM BILLING

In order to reduce the proportion of clerical and shipping costs on small orders, the minimum billing per order is \$10.00. This minimum applies to all purchases except repair parts and cash-with-order transactions.

## SOURCE INSPECTION SURCHARGE

A surcharge of 1 percent, \$2.50 minimum, applies on all orders requiring inspection at

	2 POUNDS				5 POUNDS				25 POUNDS				40 POUNDS			
	Air Freight	Air Express	Air Parcel Post	R.E.A. Express	Air Freight	Air Express	Air Parcel Post	R.E.A. Express	Air Freight	Air Express	Truck or Rail Freight Forwarder	R.E.A. Express	Air Freight	Air Express	Truck or Rail Freight Forwarder	R.E.A. Express
BUFFALO.....	\$9.65	\$6.27	\$1.15	\$2.79	\$9.65	\$6.27	\$2.65	\$3.00	\$9.65	\$8.02	\$5.40	\$4.41	\$9.65	\$10.05	\$5.40	\$5.47
CLEVELAND.....	10.45	6.27	1.15	2.82	10.45	6.27	2.65	3.07	10.45	9.62	5.87	4.76	10.45	12.61	5.87	6.02
DETROIT.....	10.85	6.27	1.15	2.84	10.85	6.27	2.65	3.13	10.85	9.62	5.87	5.02	10.85	12.61	5.87	6.44
CHICAGO.....	12.00	6.27	1.26	2.86	12.00	6.27	2.94	3.20	12.00	12.02	6.76	5.37	12.00	16.45	6.76	6.99
ST. LOUIS.....	12.65	6.27	1.39	2.57	12.65	6.30	3.31	2.89	12.65	12.82	7.41	5.11	12.65	17.73	7.41	6.76
ATLANTA.....	12.45	6.27	1.26	2.55	12.45	6.27	2.94	2.87	12.45	12.02	5.56	4.96	12.45	16.45	5.56	6.51
HOUSTON.....	15.75	6.27	1.47	2.65	15.75	7.26	3.63	3.12	15.75	17.62	9.52	6.19	15.75	25.41	9.52	8.50
DALLAS.....	15.90	6.27	1.47	2.65	15.90	7.26	3.63	3.10	15.90	17.62	9.28	6.12	15.90	25.41	9.28	8.36
LOS ANGELES.....	22.15	6.27	1.60	2.80	22.15	8.54	4.00	3.45	22.15	24.02	11.81	7.88	22.15	35.65	11.81	11.19
SEATTLE.....	22.15	6.27	1.60	2.78	22.15	8.54	4.00	3.44	22.15	24.02	11.81	7.82	22.15	35.65	11.81	11.10

	75 POUNDS				100 POUNDS				200 POUNDS				400 POUNDS			
	Air Freight	Air Express	Truck or Rail Freight Forwarder	R.E.A. Express	Air Freight	Air Express	Truck or Rail Freight Forwarder	R.E.A. Express	Air Freight	Air Express	Truck or Rail Freight Forwarder	R.E.A. Express	Air Freight	Air Express	Truck or Rail Freight Forwarder	R.E.A. Express
BUFFALO.....	\$10.95	\$14.78	\$5.40	\$7.96	\$10.95	\$18.16	\$5.40	\$9.72	\$16.75	\$36.12	\$8.42	\$19.24	\$28.80	\$72.04	\$15.84	\$38.28
CLEVELAND.....	13.15	19.58	5.87	8.99	13.15	24.56	5.87	11.10	20.85	48.92	9.72	22.00	40.20	97.64	16.44	43.80
DETROIT.....	13.60	19.58	5.87	9.75	14.32	24.56	5.87	12.12	23.29	48.92	9.72	24.04	45.08	97.64	17.24	47.88
CHICAGO.....	15.25	26.78	6.76	10.79	16.80	34.16	6.76	13.49	28.10	68.12	10.60	26.78	55.40	136.04	20.20	53.36
ST. LOUIS.....	16.40	29.18	7.41	10.63	18.25	37.36	7.41	13.39	31.35	74.52	11.68	26.58	61.60	148.84	22.36	52.96
ATLANTA.....	16.20	26.78	5.56	10.16	16.95	34.16	5.56	12.77	28.95	68.12	11.12	25.34	56.40	136.04	22.24	50.48
HOUSTON.....	21.25	43.58	9.52	13.89	24.15	56.56	9.52	17.73	43.55	112.92	15.20	35.26	86.00	225.64	29.40	70.32
DALLAS.....	21.40	43.58	9.28	13.64	25.36	56.56	9.28	17.42	45.82	112.92	14.80	34.64	90.24	225.64	28.60	69.08
LOS ANGELES.....	30.65	62.78	11.81	18.93	38.18	82.16	11.81	24.45	71.36	164.12	23.62	48.70	141.92	328.04	47.24	97.20
SEATTLE.....	30.65	62.78	11.81	18.76	37.56	82.16	11.81	24.23	69.97	164.12	23.62	48.26	138.24	328.04	47.24	96.32







our plant either by one of the Government services or by the customer's own inspection department or other private agency. The inspection surcharge applies on each shipment source inspected.

**CONDITIONS OF SALE**

Determination of prices, terms and conditions of sale, and final acceptance of orders are made only at our factory, West Concord, Massachusetts.

**Domestic Terms:** Net 30 days if credit has been arranged; otherwise unless payment is received before shipment, shipment will be made C.O.D.

When full payment accompanies an order for equipment, except for repairs, we pay transportation charges to any point in the continental United States (not including Alaska and the Canal Zone) on carrier of our choice.

**Export Terms:** Full payment in advance of shipment or by sight-draft against irrevocable letter of credit at New York or Boston bank.

**REMITTANCES:**

Should be made payable at par in Boston or New York funds.

**PRICE CHANGES**

All prices are subject to change without notice. Formal price quotations remain open for 30 days.

Prices shown will be increased by the amount of any applicable sales, use, excise, or similar taxes that are now in effect or that may hereafter be imposed by Federal, State, or local governments.

**NO TRADE OR EDUCATIONAL DISCOUNTS**

Our prices are established on a direct-to-customer basis, which permits no special discounts. By the elimination of distribution or resale discounts, all users pay the lowest possible prices.

**QUANTITY DISCOUNTS**

When 10 or more identical parts or Variac® autotransformers (not instruments) are ordered at the same time for single shipment to a single destination in the continental United States (not including the Canal Zone) and Canada, the following quantity discounts are allowed except as noted otherwise:

- 10-19 . . . . . 5 percent
- 20-99 . . . . . 10 percent
- 100 or more . . . . . 15 percent

Questions regarding the applicability of quantity discounts to any item in this catalog will be answered promptly by our Sales Engineering or Commercial Departments.

**SPECIFICATION CHANGES**

We reserve the right to discontinue any item without notice and to change specifications at any time without incurring any obligation to incorporate new features in instruments or parts previously sold.

**WARRANTY**

We warrant that each new instrument sold by us is free from defects in material and workmanship and that properly used it will perform in full accordance with applicable specifications for a period of *two years* after original shipment. Any instrument or component that is found within the two-year period not to meet these standards after examination by our factory, district office, or authorized repair agency personnel will be repaired or, at our option, replaced without charge, except for tubes or batteries that have given normal service.

**REPAIR PARTS**

When ordering repair parts, be sure to describe completely the parts required, using the symbol numbers and description from the parts list, and give the type number and serial number of the instrument.

**RETURNED MATERIAL**

Repair service is available from the factory, West Concord, Mass., or from the Repair Services listed on the inside front cover of this catalog.

When returning instruments for repair, recalibration, or for any other reason, please ask for a Return Material Tag and shipping instructions. Please state type number and serial number of the instrument and date of purchase.

**DOMESTIC SALES AGENCIES**

Because of our direct-sales policy no general sales agencies are appointed. Complete stocks are carried only at the factory warehouse. Partial stocks are maintained at all of our district offices (see inside front cover).

**EXPORT REPRESENTATIVES**

Export sales are handled by resident representatives in most overseas countries. Complete technical and commercial information is available from these representatives, at the addresses listed on the inside back cover of the catalog.



## VISIT OUR LABORATORIES AND FACTORY

We cordially invite you to visit our engineering laboratories and factory.

HOURS FOR VISITORS: 10:00 A.M. to 4:00 P.M. every day except Saturdays, Sundays, and legal holidays in Massachusetts.

Our plant is located in West Concord at 22 Baker Avenue. This is a short distance from the intersection of State Routes 2 and 62, and the accompanying map gives details of this area.

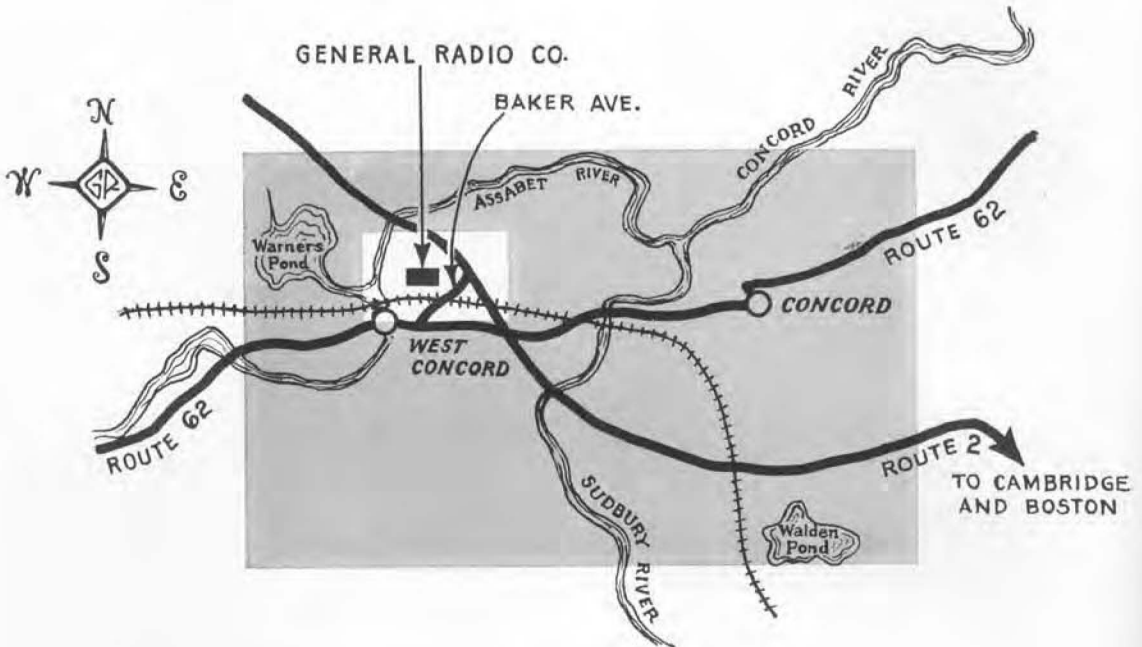

## PATENTS

Many of our products are manufactured and sold under United States Letters Patent owned by the General Radio Company or under license grants from other companies. To simplify the listing of these patents they are given here in a single list and referred to at each instrument only by appropriate reference number.

1. "Certain vacuum-tube amplifier devices, electric wave filters, vacuum-tube oscillators, and sound-level meters are licensed by Western Electric Company, Inc., under all United States Letters Patent owned or controlled by American Telephone and Telegraph Company, or Western Electric Company, Inc., and any or all other United States patents with respect to which Western Electric Company, Inc., has the right to grant a license, solely for utilization in research, investigation, measurement, testing, instruction, and development work in pure and applied science, including engineering and industrial fields."

2. "This apparatus uses inventions of United States Patents licensed by Radio Corporation of America. Patent numbers supplied upon request. Licensed only for use in measuring or testing electronic devices,

electron tube circuits, parts of such devices and circuits, and elements for use in such devices and circuits."

3. Patent D 161,030.
4. Patent 2,548,457.
5. Patent 2,802,907.
6. Licensed under designs, patents and patent applications of Edgerton, Germeshausen and Grier,
7. Patent 2,949,592.
8. Patent Applied For.
9. Patent Re 24,204.
10. Patent 2,367,681.
11. Patent 2,374,248.
12. Patent 2,376,394.
13. Patents D 142,777 and D 143,807.
14. Patent 2,763,733.
15. Patent D 187,740.
16. Patent 2,362,503.
17. Patent 2,354,718.
18. Patent 2,581,133.
19. Patent 2,872,639.
20. Patent 2,943,277.
21. Patent 2,942,172.
22. Patent 2,966,257.

# IMPEDANCE-MEASURING INSTRUMENTS



For the measurement of all types of impedance, resistive or reactive, inductive or capacitive, at frequencies well up into the uhf band, null methods have proved to be the most acceptable on grounds of both precision and convenience. Most of the null methods used from dc to radio frequencies of the order of 100 megacycles are adaptations of the fundamental Wheatstone bridge circuit, although other types of networks which can be adjusted to give zero transmission are sometimes used. Other systems, such as resonant circuits, using deflec-

tion-type instruments also have advantages for certain applications.

At very-high and ultra-high frequencies, where impedances can no longer be treated as lumped elements, bridge circuits based on coaxial-line techniques have been developed in the General Radio laboratories. Impedance can also be determined at these frequencies from a measurement of the standing-wave ratio that the unknown element introduces into a smooth transmission line. Slotted lines for this measurement are described in the coaxial equipment section.

## DIRECT-CURRENT BRIDGES

The so-called Wheatstone bridge, Figure 1, has been used for over a century for the measurement of direct-current resistance and is still considered the fundamental circuit for the purpose. It measures an unknown resistance in terms of calibrated standards of resistance from the relationship:

$$\frac{R_A}{R_B} = \frac{R_N}{R_P} \quad (1)$$

which is satisfied when the voltage across the detector terminals is zero.

The General Radio Company manufactures three dc Wheatstone bridges:

TYPE	NAME	RANGE OF MEASUREMENT	ACCURACY	REMARKS	SEE PAGE
1650-A	Impedance Bridge	1 mΩ to 1 MΩ	±1% ± 1 mΩ	Also measures ac R, L, C	22
1652-A	Resistance Limit Bridge	1 Ω to 1 MΩ	0.5% as limit bridge 0.25% by null method	Equally useful as production or laboratory bridge	6
544-B	Megohm Bridge	0.1 MΩ to 1 MMΩ	3% up to 1000 MΩ	Excellent for measuring resistors and insulation resistance	8

## ALTERNATING-CURRENT BRIDGES

The basic circuit of Figure 1 is also applicable to alternating-current measurements. With impedances substituted for resistances, two conditions of balance must be satisfied, one for the resistive component and one for the reactive component. The equations of balance can be written in either of the following forms:

$$R_P + jX_P = Z_A Z_N Y_B \quad (2)$$

$$G_P + jB_P = Y_A Y_N Z_B \quad (3)$$

Equation (2) expresses the unknown in terms of its impedance components, while Equation (3) expresses the unknown in terms of its admittance components. To sat-

isfy these equations, at least one of the three arms A, P, or B must be complex.

The reactance  $X_P$  can be measured in terms of a similar reactance in an adjacent arm or an unlike reactance in the opposite arm, as indicated in Figure 2.

**Resistive Balance** Figure 3 shows the four basic methods in common use for balancing the loss component of the unknown impedance. These are (a) resistance in series with the standard reactance, (b) resistance in parallel with the standard reactance, (c) capacitance in parallel with a resistive arm, and (d) capacitance in series with a resistive arm.

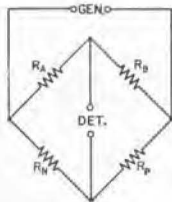

(Left) Figure 1. The general Wheatstone bridge circuit.

(Right) Figure 2. Circuits for capacitance bridges in which like reactances,  $C_N$  and  $C_P$ , or unlike reactances,  $L_A$  and  $C_P$ , are compared.

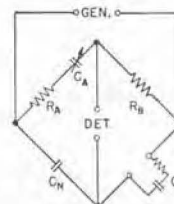
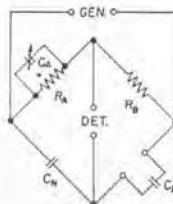
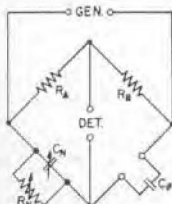
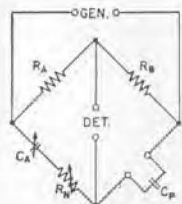
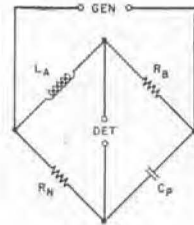
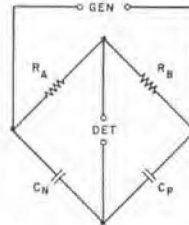

Figure 3. Four basic methods of obtaining resistance balance.



**Dissipation Factor and Storage Factor** An important characteristic of an inductor or a capacitor is the ratio of resistance to reactance or of conductance to susceptance. This ratio is termed dissipation factor,  $D$ , and its reciprocal is storage factor,  $Q$ . These ratios are defined in Figure 4 in terms of phase angle  $\theta$  and loss angle  $\delta$ . Dissipation factor is directly proportional to the energy dissipated, and storage factor to the energy stored, per cycle. Power factor is defined as

$$\text{P. F.} = \cos \theta = \sin \delta$$

and differs from dissipation factor by less than 1% when their values are less than 0.1.

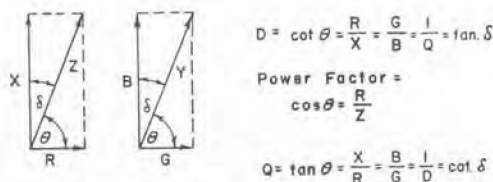

Figure 4. Vector diagram showing the relations between factors  $D$  and  $Q$ , and angles  $\theta$  and  $\delta$ .

In Figure 4,  $R$  &  $X$  are the series resistance and reactance, and  $G$  and  $B$  are the parallel conductance and susceptance of the impedance or admittance involved.

Dissipation factor, which varies directly with the loss, is commonly used for capacitors and, to a lesser extent, for inductors. Its reciprocal, storage factor,  $Q$ , is more often used for inductors, because it is a measure of the voltage step-up in a tuned circuit.

The circuit can often be arranged so that the bridge control for the resistive balance can be calibrated in dissipation factor or in storage factor, for a given frequency.

**Series and Parallel Components** Every impedance can be expressed in terms of either series or parallel components. The choice is a matter of convenience for the problem at hand. One cannot tell from a single measurement whether a combination of a resistive and a reactive element is actually parallel or series, and regardless of the physical configuration, the resistive and reactive components can be measured as, and expressed as, (1) series impedance components, (2) parallel impedance components, or (3) admittance components.

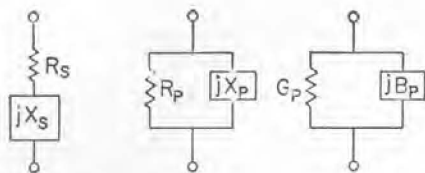

Figure 5. Series and parallel components of impedance.

The relation between these various systems (see Figure 5) are:

$$R_P = \frac{1}{G_P} = \frac{R_S^2 + X_S^2}{R_S} = R_S (1 + Q^2)$$

$$X_P = \frac{1}{B_P} = \frac{R_S^2 + X_S^2}{X_S} = X_S (1 + D^2)$$

So that:

$$C_P = C_S \left( \frac{1}{1 + D^2} \right); C_S = C_P (1 + D^2)$$

$$L_P = L_S \left( 1 + \frac{1}{Q^2} \right); L_S = L_P \left( \frac{Q^2}{1 + Q^2} \right)$$

Where:

$$Q = \frac{X_S}{R_S} = \frac{R_P}{X_P} = \frac{B_P}{G_P} \quad D = \frac{1}{Q} = \frac{R_S}{X_S} = \frac{X_P}{R_P} = \frac{G_P}{B_P}$$

It should be noted that only for values of  $Q$  below 10 (or  $D > .1$ ) does the difference between series and parallel reactance exceed 1%. For very low  $Q$ 's, however, the difference is marked; when  $Q = 1$ , the parallel reactance is twice the series reactance. It is obvious that if there were no losses in the reactive elements (i.e.,  $G = \infty$ ), series and parallel reactance would be equal.

Whether a bridge measures series or parallel components depends upon its own configuration of elements. Measurements with the bridge shown in Figure 3b, for example, will yield parallel values for the unknown. Similarly the bridge of Figure 3a will give series values.

**Substitution Methods** Substitution methods of measurement, as contrasted to the direct method described, can be used to advantage with all ac bridges. In this method the unknown is measured in terms of the difference between two settings of a calibrated resistance or reactance. In the measurement of capacitance by a parallel substitution method, for instance, as shown in Figure 6, the unknown capacitance is connected in parallel with an adjustable calibrated capacitor in either the N- or P-arm of the previously balanced bridge, and the calibrated element is readjusted until the bridge is again in balance.

Increased accuracy in the capacitance measurement results from the fact that the measurement is solely in terms of the difference between two settings of a calibrated precision capacitor, the bridge circuit functioning only as an indicator of identical balance conditions. The bridge circuit does, however, enter into the determination of dissipation factor.

The series substitution method of Figure 7 is used to make resistance and reactance dials direct reading in ohms, on the radio frequency bridges.

## TRANSFORMER BRIDGES

Transformer windings, which can provide extremely precise voltage ratios, will perform the same function as ratio arms in conventional bridge circuits. They have the further advantage of very low impedance to ground, which greatly lessens the effects of stray shunt imped-

ances, and, in the Type 1613-A Capacitance Bridge, obviates the need for a guard circuit when 3-terminal capacitors are measured. Transformer ratio arms are also used in the Type 1605-A Impedance Comparator.



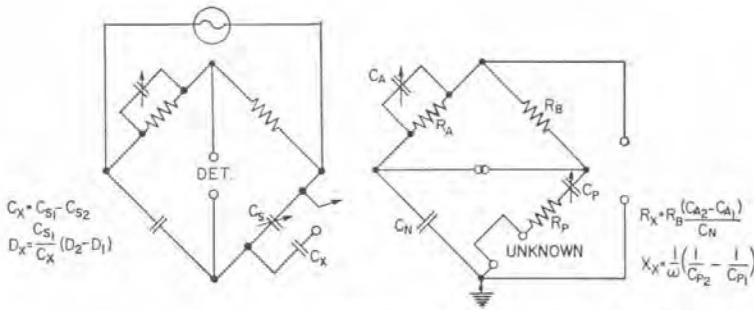

(Left) Figure 6. Parallel substitution method of measurement. (Right) Figure 7. Circuit for series substitution method.

LIMIT BRIDGES AND COMPARATORS

In limit testing the unbalance voltage of the bridge is used to actuate meters that indicate the degree of deviation of one impedance from another. In the Type 1652-A Resistance-Limit Bridge an adjustable resistance standard is included and the instrument is thus a complete system for limit testing of resistors over a wide range of values. Also the operation can be inverted, i.e.,

the bridge balanced as in a conventional bridge, and the answer read on the dials of the internal standards.

The Type 1605-A Impedance Comparator uses a phase-selective voltage measuring system, and the quadrature components of the difference between the unknown and an external standard impedance are displayed independently on the two meters.

AC BRIDGES

TYPE	NAME	MEASURES	NOMINAL ACCURACY	FREQUENCY	REMARKS	SEE PAGE
<b>Power-Frequency Bridges</b>						
1611-B	Capacitance Test Bridge	C 0 to 11,000 $\mu$ f D 0 to 60%	$\pm 1\%$ $\pm 2\%$	60, 120 cps	For testing insulators, bushings, capacitors, cables, and polarized electrolytic capacitors. Measures grounded capacitors.	10
740-B	Capacitance Test Bridge	C 5pf to 1100 $\mu$ f D 0 to 50%	$\pm 1\%$ $\pm 1.5\%$	60cps	Measures ungrounded capacitors.	12
<b>Audio-Frequency Bridges</b>						
1650-A	Impedance Bridge	R 1m $\Omega$ to 1 M $\Omega$ C 1pf to 1000 $\mu$ f L 1 $\mu$ h to 1000 h Also D and Q	$\pm 1\%$ $\pm 1\%$ $\pm 1\%$	dc, 1 kc	Completely self-contained, general purpose, laboratory and production bridge. Belongs in every laboratory and electronic plant.	22
1603-A	Z-Y Bridge	R,X 0-1000 $\Omega$ G,B 0-1000 $\mu$ mho	$\pm 1\%$ $\pm 1\%$	20 cps-20 kc	Will balance for any impedance from 0 to $\infty$ . Ideal for measuring audio-frequency transducers.	24
716-C	Capacitance Bridge	C 100pf to 1 $\mu$ f C 100 to 1000pf C 0.1 to 1000pf D 0.00002 to 0.56	$\pm 0.1\%$ $\pm 0.1\%$ $\pm 0.2\%$ $\pm 2\%$	1 kc 30 cps to 300 kc 30 cps to 300 kc 30 cps to 300 kc	Direct Reading Direct Reading Substitution Method	13
1613-A	Capacitance Bridge	C 5pf to 0.011 $\mu$ f D 0 to 0.11	$\pm 0.1\%$ $\pm 2\%$	400 cps	Measures 3-terminal capacitors.	18
1632-A	Inductance Bridge	L 0.001 $\mu$ h to 1111h G 0.01 $\mu$ mho to 1111mho	$\pm 0.1\%$ $\pm 1\%$	1 kc	Measures both series and parallel inductance.	20
1605-A	Impedance Comparator	$\Delta Z$ $\pm 0.01\%$ to $\pm 10\%$ $\Delta \theta$ $\pm 0.001$ to $\pm 0.1$ radian	$\pm 0.01\%$	0.1, 1, 10, 100 kc	Direct indication on meters, no balancing. Guard circuit included.	26
<b>Radio-Frequency Bridges</b>						
716-CS1	Capacitance Bridge	C 0.1-1100pf D 0.00002 to 0.56	$\pm 0.1\%$ $\pm 2\%$	0.5 to 3 Mc	High-frequency model of Type 716-C.	33
916-AL	Radio Frequency Bridge	X $\pm 11,000 \Omega$ at 100 kc R 0 to 1000 $\Omega$	$\pm 2\%$ $\pm 1\%$	50 kc to 5 Mc	Use for measuring antennas, lines, components.	32
1606-A	Radio Frequency Bridge	X $\pm 5000 \Omega$ at 1 Mc R 0 to 1000 $\Omega$	$\pm 2\%$ $\pm 1\%$	0.4 to 60 Mc	Use for measuring antennas, lines, components.	30

For a more complete discussion of bridge circuits see "Impedance Bridges Assembled from Laboratory Parts," by Ivan G. Easton. Copy free on request.



(Right) Figure 9. Elementary schematic circuit diagram of the Type 716-P4 Guard Circuit connected to the Type 716-C Capacitance Bridge showing the unknown capacitance and its terminal impedances.

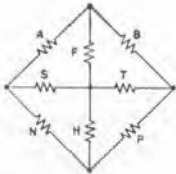
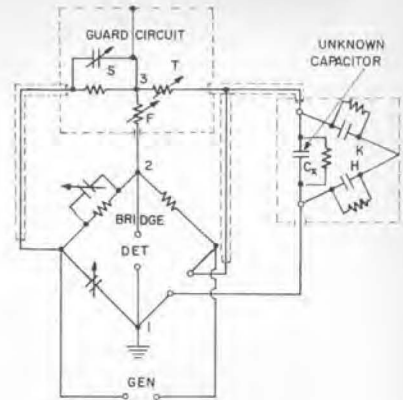

(Left) Figure 8. General bridge network with guard circuit, and unknown three-terminal impedance.

**Guard Circuit** Whenever the impedance to be measured is located at an appreciable distance from the bridge, or when it has appreciable capacitance from its terminals to ground, a guard circuit can be used to eliminate the effects of the unwanted residual impedances. The use of the guard circuit permits the accurate measurement of the direct capacitance and dissipation factor between two terminals of a three-terminal network. One of the most important applications of such a measurement arises in the determination of the properties of dielectric materials. A guard electrode, which forms, with the two measuring electrodes, a three-terminal system, is often employed in such determinations to eliminate effects of variable lead parameters as temperature or other conditions are changed. A guard circuit, TYPE 716-P4, is available for use with the TYPE 716-C Capacitance Bridge, and guard terminals are provided on the TYPE 544-B Megohm Bridge and the TYPE 1605-A Impedance Comparator.

Figure 8 is a schematic of a generalized bridge network with guard circuit. It can be shown that the net-

work is in balance if either of the following conditions is met:

$$\frac{A}{N} = \frac{B}{P} = \frac{F}{H} \quad \frac{A}{B} = \frac{N}{P} = \frac{S}{T}$$

Obviously these conditions include the ordinary equation of balance of the four-arm network A-B-N-P.

Figure 9 shows the elementary schematic diagram of the guard circuit, used with the TYPE 716-C Capacitance Bridge. In this circuit the guard point is brought to ground potential by successive balancing of the bridge alone and of the bridge and guard circuit (ST) in parallel. This balance is facilitated by additional balances first of the bridge alone and then with the coupling circuit (FH) connected. Impedance H is supplied by the capacitance of the ground terminal of the unknown ( $C_x$ ) to shield. At final balance, terminals 3, 2, and 1 are all at the same potential. Impedance K has no effect, because it is part of the guard-circuit impedance, T. Both ends of impedance H are at the same potential, so that it has no effect. Hence, the impedance measured is that of  $C_x$  alone.

COAXIAL LINE INSTRUMENTS

TYPE	NAME	MEASURES	NOMINAL ACCURACY	FREQUENCY	REMARKS	SEE PAGE
1602-B	Admittance Meter	B, G 0.1 to 1000 mmho X, R 1 to 10,000 ohms	±3%	20 to 1500 Mc	For admittance, impedance, and VSWR measurements on coaxial lines, antennas, networks, components	34
1607-A	Transfer Function and Imittance Bridge	$Z_{21}$ 0 to 1500 ohms $Y_{21}$ 0 to 600 mmhos $V_2/V_1$ 0 to 30 $I_2/I_1$ 0 to 30 B, G 0 to 400 mmho X, R 0 to 1000 ohms	±5%	25 to 1500 Mc	Measures four-terminal transfer functions of tubes, transistors and networks; also 2-terminal functions, impedance and admittance	36
874-LBA	Slotted Line	VSWR	3% or better	300 to 5000 Mc	Standard instrument for uhf impedance and VSWR measurement	52

**The Admittance Meter** The upper-frequency limit of conventional bridge circuits using lumped-parameter elements is determined by the magnitude of the residual impedances of the elements and leads. In general, the corrections for these become unmanageable at frequencies higher than a few hundred megacycles, and circuits based on coaxial-line techniques are more satisfactory.

The TYPE 1602-B UHF Admittance Meter (see page 34) is a null device based on these techniques. Through adjustable loops, it samples the currents flowing in three coaxial lines fed from a common source at a common junction point and terminated, respectively, in the unknown element, a standard conductance, and a standard susceptance. The outputs of the loops are combined, and when the loops are properly oriented, the combined



output becomes zero, so that a null balance is produced. Scales associated with the three loops give the value of the unknown admittance directly.

**The Transfer Function and Imittance Bridge** Like the Admittance Meter, the Transfer Function and Imittance Bridge is a null instrument using coaxial lines and adjustable coupling loops. A schematic is shown on page 37. It can measure 4-terminal functions, such as forward and reverse transconductance and transsusceptance, transimpedance, input-output ratios of voltage and current, and output-input ratios, as well as the 2-terminal functions of admittance and impedance.

This instrument is particularly useful for evaluating the transfer functions of vacuum tubes and transistors in the vhf and uhf ranges.

**The Slotted Line** One of the basic methods of determining impedance of a coaxial device is the measurement of the standing-wave ratio it introduces into a smooth line. The measurement is made by means of a coaxial line in whose outer conductor is a longitudinal slot. An electrostatic probe enters the line through this slot and can be moved along the line to sample the electric field between the inner and outer conductors. From the voltage maximum and minimum, and their location with respect to the unknown, the impedance can be calculated.

The TYPE 874-LBA Slotted Line for general impedance measurement is described in the Coaxial Section, pages 38 to 55.

## DETECTORS

(See also the discussion of detectors on page 56).

To obtain the maximum precision of balance with any bridge or null-balance circuit, it is necessary to obtain a virtually complete null balance. With modern amplifiers, however, sufficient sensitivity can be obtained to utilize all the potential precision of any null-balance network, even with relatively low applied bridge voltage.

The desirable characteristics of a bridge detector are:

(1) High sensitivity, preferably the ability to detect a few microvolts.

(2) High selectivity, to reject harmonics, noise, or other interfering signals. This is particularly important in measuring iron-cored coils and other nonlinear elements.

(3) Quasi-logarithmic response, to obviate the necessity of gain adjustments during the balancing procedure. These requirements are best met by some combination of amplifier, filter, and null indicator. At audio frequencies, a tuned amplifier with meter or earphones is satisfactory. The TYPE 1232-A Null Detector and Amplifier is a high-sensitivity device of this type. With visual indicators, such a system can also be used at frequencies up to several megacycles (TYPE 1212-A).

From a few hundred kilocycles to some 40 megacycles, well-shielded radio receivers make excellent detectors, while at very-high and ultra-high frequencies the preferred system is a heterodyning oscillator, mixer, and fixed-frequency amplifier (TYPE DNT).

## GENERATORS

The important considerations in the selection of a power source for ac bridge measurements are good frequency stability, adequate power output, and low harmonic content. For those General Radio bridges that require external generators, a wide choice is available.

For single-frequency measurements at 400 or 1000 cycles, the TYPE 1214-A Oscillator is satisfactory. For measurements over a range of frequencies, recommended oscillators are the TYPES 1301-B, 1210-C, and 1302-A at low and audio frequencies; the TYPES 1330-A and 1211-B at medium frequencies; and, from 0.5 Mc to

2000 Mc, the various vhf and uhf Unit Oscillators and the TYPE 1361-A UHF Oscillator.

## CONNECTIONS-SHIELDING

Adequate ground connection and shielded generator and detector leads are necessary precautions in any bridge measurements, but are particularly important at high frequencies. At audio and low-radio frequencies, electrostatic shielding of the leads is usually all that is necessary; above a few megacycles, coaxial leads must be used, and these must be securely grounded to the detector, generator, and bridge shields to provide a completely shielded system, and to eliminate common impedances between generator and detector.

## SPECIALIZED MEASUREMENTS

**Vacuum Tubes and Transistors** No single device will measure all the desired characteristics of tubes and transistors, nor will it measure any one property at all frequencies. The fundamental vacuum-tube parameters — plate resistance, amplification coefficient, and transconductance — are measured easily and accurately at low frequencies by the TYPE 1661-A Vacuum-Tube Bridge. Of transistors, it will measure the short-circuit conductance parameter, including the  $h_i$  hybrid parameter, and the forward and reverse voltage ratios, including the  $h_r$  hybrid parameter. The  $h_f$ ,  $\alpha$ , and  $\beta$  factors as well as other open-circuit parameters can be calculated from these measurements.

At very high and ultra-high frequencies the TYPE 1607-A Transfer Function and Imittance Bridge measures important parameters of both tubes and transistors. For transistors, these include short-circuit current gain, open-circuit voltage-feedback factor, hybrid input impedance and hybrid output admittance. For tubes, they include open-circuit voltage gain, trans-admittance, feedback admittance, and input and output admittance. These last two quantities can be measured at low frequencies by the TYPE 1603-A Z-Y Bridge.

The equivalent-circuit parameters of tunnel diodes at high frequencies can also be measured on the Transfer-Function and Imittance Bridge.

Small capacitances, such as the collector-to-base capacitance of a transistor, are easily measured on the TYPE 1605-A Impedance Comparator. A similar method of measurement is used to determine the small phase angles of high resistances.

TYPE	NAME	SEE PAGE
1661-B	Vacuum-Tube Bridge	28
1607-A	Transfer Function and Imittance Bridge	36
1603-A	Z-Y Bridge	28

**Dielectric Measurements** For the measurement of the dielectric constant and dissipation factor of insulating materials, the TYPE 716-C Capacitance Bridge is recommended at low frequencies (up to 100 kc), and the TYPE 716-CS1 up to 5 Mc. With the bridges, the TYPE 1690-A Dielectric Sample Holder is useful in 2-terminal measurements. The TYPE 716-P4 Guard Circuit can be used with the TYPE 716-C Capacitance Bridge when the sample is in a conditioning chamber, or, alternatively, the TYPE 1605-A Impedance Comparator, with its built-in guard, can be used for the measurement.

TYPE	NAME	SEE PAGE
716-C	Capacitance Bridge	13
716-CS1	Capacitance Bridge	33
1605-A	Impedance Comparator	26
1690-A	Dielectric Sample Holder	17





## TYPE 1652-A RESISTANCE LIMIT BRIDGE

A LIMIT BRIDGE FOR RAPID TESTING

A WHEATSTONE BRIDGE FOR THE LABORATORY

**USES:** The Resistance Limit Bridge is intended primarily for dc production testing of resistors. It can be used —

- To indicate percentage deviation from an internal standard.
- To match pairs of resistors.
- To compare resistors to a standard sample.
- To measure resistance precisely by the null method.

For manufacturers and users of resistors, this bridge offers an accurate and rapid means of separating resistors into tolerance classifications and for selecting resistors to close tolerances. The manufacturer of electronic equipment can use it to advantage in matching pairs of resistors for operation in balanced circuits.

Its accuracy is adequate for all but the most exacting requirements in the laboratory, and its ability to measure resistors as large as one megohm without the inconvenience of adding booster batteries makes it much more convenient than the ordinary decade bridge.

The bridge can also be adapted for use as the control unit in automatic sorting or inspecting. A relay, in conjunction with external amplification, can be substituted for the indicating meter, to actuate various types of selection mechanisms. By adjustment of the sensitivity of the relay, end points can be es-

tablished to determine tolerances such as  $\pm 5\%$ ,  $\pm 10\%$ , and  $\pm 20\%$ .

**DESCRIPTION:** The TYPE 1652-A Resistance Limit Bridge uses the conventional equal-arm Wheatstone bridge circuit. The bridge is supplied from a constant-voltage dc source, and its indicating meter is calibrated in percentage difference between the unknown and the standard over a range of  $\pm 20\%$ .

A built-in standard consisting of seven TYPE 510 Decade Resistors is adjustable from one ohm to 1,111,111 ohms in 0.1-ohm steps.

Measurements are made simply; the standard is set to the nominal value of the resistor under test, and the percentage difference is indicated on the meter. The test procedure can

Schematic circuit diagram of the Type 1652-A Resistance Limit Bridge.

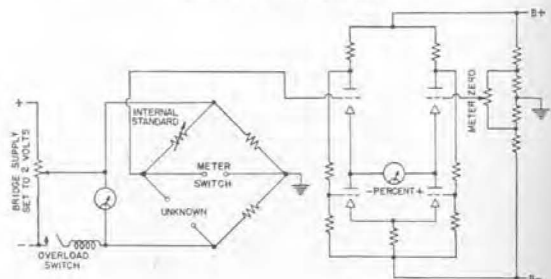





be greatly facilitated by the use of a test fixture (such as the TYPE 1650-P1, page 23) into which the resistors can be plugged, and which can be operated in conjunction with a switch that shorts the meter circuit prior to removal of the resistor from the jig. Panel terminals for such a switch are provided.



Resistance Limit Bridge used to test relay coils for precision relays and switches.

For the matching of resistors, the resistor to be matched is connected to terminals provided and the internal standard is set to zero.

Used as a conventional Wheatstone bridge, the circuit is balanced by adjustment of the internal standard to equality with the unknown resistor; the calibrated meter is used as a null indicator.

### FEATURES:

- Rapid and accurate for limit tests.
- Extreme simplicity of operation.
- Large meter scale, colored gold for 5% limits and silver for 10% limits.
- Equally useful for general resistance measurement.
- Covers a wide resistance range — one ohm to one megohm.
- No batteries required. Operates from 115-volt or 230-volt, 60-cycle line.
- Ruggedly constructed and enclosed in welded aluminum cabinet.
- Accurate — can measure resistors to an accuracy of  $\pm 0.25\%$ .
- Indicating meter cannot be damaged by unbalance of bridge.

### SPECIFICATIONS

**Resistance Range:** As a limit bridge, 1 ohm to 1,111,111 ohms with internal standard; for null measurement, 1 ohm to 1,111,111 ohms with internal standard; 1 ohm to 2 megohms with external standard.

**Limit Range:** Meter reads from  $-20\%$  to  $+20\%$ , with the standard EIA (RETMA) tolerance range of  $\pm 5\%$  and  $\pm 10\%$  clearly indicated by gold and silver coloring, respectively.

**Accuracy:** As a limit bridge,  $\pm 0.5\%$  or better; for matching,  $\pm 0.2\%$ ; for null measurement, with internal standard,  $\pm 0.25\%$  above 10 ohms and  $\pm 0.4\%$  between 1 ohm and 10 ohms; with an external standard, from 1 ohm to 2 megohms  $\pm (0.2\% + \text{accuracy of standard})$ .

**Voltage Applied to Unknown:** One volt when the meter indication is zero. As the meter indication varies from

$-20\%$  to  $+20\%$  the voltage across the unknown will vary from 0.89 volt to 1.10 volts.

**Power Supply:** 105 to 125 (or 210 to 250) volts, 60 cps. The power input is approximately 30 watts.

**Accessories Supplied:** TYPE CAP-22 Three-Wire Power Cord, spare fuses.

**Tube Complement:** One TYPE 6X4 and two TYPE 6SU7-GTY's.

**Mounting:** The bridge is supplied for either relay rack or bench mounting. Cabinet has wrinkle finish.

**Dimensions:** Width 19, height  $8\frac{3}{4}$  inches (485 by 225 mm); depth behind panel; bench model,  $11\frac{1}{4}$  inches (290 mm); relay-rack model,  $10\frac{3}{4}$  inches (275 mm).

**Net Weight:** 29 pounds (13.5 kg).

TYPE		CODE WORD	PRICE
1652-AM	Resistance Limit Bridge (Bench Model.....)	BUXOM	\$520.00
1652-AR	Resistance Limit Bridge (Relay-Rack Model)...	BADGE	520.00
1652-AMQ1	Resistance Limit Bridge (50 cps).....	BUXOMRABID	645.00
1652-ARQ1	Resistance Limit Bridge (50 cps).....	BADGERABID	645.00

**MEGOHM BRIDGE:** The TYPE 544-B Megohm Bridge (page 8) is a Wheatstone bridge for measurements from 0.1 megohm to 1,000,000 megohms. The TYPE 1862-B Megohmmeter (page 130) and the TYPE 1230-A DC Amplifier and Electrometer (page 128) are also designed for measurements in the megohm range.

**AC LIMIT BRIDGE:** The TYPE 1605-A Impedance Comparator (page 26) is designed for the rapid comparison of resistors, capacitors and inductors at 0.1, 1, 10, and 100 kc.



## TYPE 544-B MEGOHM BRIDGE

FOR MEASUREMENT OF INSULATION RESISTANCE, RESISTIVITY, DIELECTRIC ABSORPTION



using the dielectric absorption effects in the insulation of electrical machinery, transformers, and cables. Charging-current curves can be easily obtained over time intervals from one second to many hours.

With external decade resistors, the bridge can be used for intercomparison of resistance standards.

**DESCRIPTION:** The TYPE 544-B Megohm Bridge is a combination of Wheatstone bridge and vacuum-tube voltmeter.

The bridge is composed of the four arms, *A*, *B*, *N*, *P*, as shown in the diagram at the bottom of the page, with the power applied across the arms *A* and *B*, and the vacuum-tube voltmeter connected across the conjugate pairs, *A-N* and *B-P*. For checking the galvanometer zero, the tube is isolated from the bridge voltage in the CHECK position, with the high resistors, *N* and *P*, connected to the grid exactly as in the OPERATE position. The effects of any voltages, alternating or direct, in the unknown resistor, *P*, and of any grid current in the tube will not appear in the bridge balance because they are balanced out in the zero adjustment. There is also a CHARGE position, in which the unknown resistor, *P*, is placed across the arm, *B*. This is valuable in measuring the resistance of large capacitors because full voltage is applied directly to the capacitor, which can then

**USES:** The TYPE 544-B Megohm Bridge is very useful for measurement of all types of resistances in the megohm ranges. These include composition, film, and carbon resistors; insulation resistance of electrical machinery such as generators, motors, and transformers; of electrical equipment such as rheostats and household appliances; of single conductors, cables and capacitors; of long sections of high-voltage cables; of paper capacitors; and of slabs of insulating materials.

Volume resistivity and its change with temperature and humidity can also be determined.

Guard connections are provided for the measurement of three-terminal resistors such as multi-wire cables, three-terminal capacitors, networks, and guarded specimens of insulating materials.

This bridge has been widely used for meas-

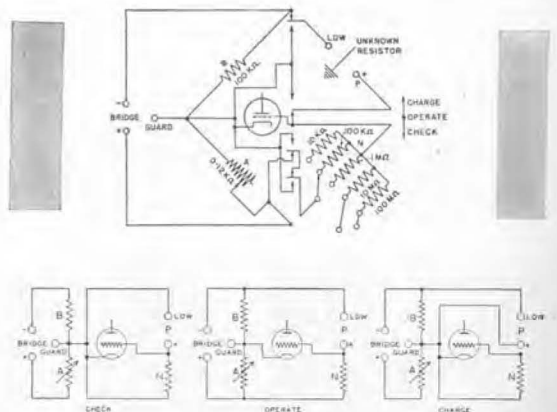

Schematic diagrams of the megohm bridge.



charge at a maximum rate. The zero of the galvanometer can also be checked at any time without being affected by the residual charge in the capacitor.

### FEATURES:

- Direct measurement as high as 1,000,000 megohms.
- Constant fractional accuracy, regardless of setting.
- Voltage applied to unknown is held approximately constant regardless of value of resistance.
- Voltage stabilization prevents surges in charging current.
- Safe to operate since all high-voltage terminals are insulated and current limiters are included in the power supply.



The Megohms dial of Type 544-B Megohm Bridge. The scale is approximately logarithmic over the main decade from 1 to 10.

### SPECIFICATIONS

**Range:** 0.1 megohm to 1,000,000 megohms, covered by a dial and a 5-position multiplier switch. A resistance of 1,000,000 megohms can be distinguished from infinity.

**Accuracy:**  $\pm 3\%$  on the 0.1, 1, and 10 multipliers;  $\pm 4\%$  on the 100 and 1000 multipliers. Above 10,000 megohms, the accuracy is essentially that with which the scale on the MEGOHMS dial can be read.

**Power Supply:** Two types of power supply are available: (1) an ac operated unit delivering dc test voltages of 500 and 100 volts to the bridge, and (2) a battery power supply of 90 volts. The ac unit operates from a 105- to 125-volt (or 210- to 250-volt), 40- to 60-cycle line. The battery power supply consists of one No. 6 dry cell and three 45-volt batteries. This supplies 45 volts for the tube anode and 90 volts for the test voltage.

The bridge with ac power unit will also operate satisfactorily from a 400-cycle supply, although line-frequency ripple will be somewhat greater than with a 60-cycle supply.

**Power Input:** 60 watts at 115 volts, 60 cps; with bat-

tery supply, approximate current requirements are 60 ma for cathode heaters and 7.5 ma for anode.

**External Bridge Voltage:** Up to 500 volts can be applied from an external source.

**Tube Complement:** With battery power supply, one 1L4; the 500-volt power supply uses one each 6K7-G, 6X5-GT, 5U4-G, 6J5-GT, 6K6-GT, 4A1, two NE-18.

**Accessories Supplied:** Test probe. With ac power supply, a TYPE CAP-22 Three-Wire Power Cord, spare fuses, spare neon ballast tube. Batteries are supplied with the battery-operated model.

**Mounting:** Shielded oak cabinet with cover.

**Dimensions:** Width 8 $\frac{1}{2}$ , height 22 $\frac{1}{2}$ , depth 8 inches (220 by 575 by 215 mm), over-all, with cover closed.

**Net Weight:** With battery power supply, 29 $\frac{1}{2}$  pounds (13.5 kg); with ac power supply, 26 $\frac{1}{2}$  pounds (12 kg); TYPE 544-P10, 14 $\frac{1}{4}$  pounds (6.5 kg); TYPE 544-P3, 11 $\frac{1}{4}$  pounds (5.2 kg).

TYPE		CODE WORD	PRICE
544-BA	Megohm Bridge, with AC Power Supply.....	AGREE	\$415.00
544-BB	Megohm Bridge, Battery Operated (Incl. Batteries)	ALOOF	290.00
544-P3	AC Power Supply Unit Only.....	AGREEAPACK	165.00
544-P10	Battery Power Supply Unit Only.....	ALOOFAPACK	40.00

**OTHER INSTRUMENTS FOR HIGH RESISTANCE MEASUREMENTS:** Two direct-indicating instruments for measuring resistances in the megohm range are the TYPE 1862-B Megohmmeter, described on page 130, and the TYPE 1230-A DC Amplifier and Electrometer, described on page 128.



## TYPE 1611-B CAPACITANCE TEST BRIDGE

WIDE-RANGE TEST BRIDGE FOR  
SHOP, FIELD, OR LABORATORY



**USES:** Capacitance and dissipation-factor measurements at 60 cps and 120 cps can be made quickly and conveniently with this bridge. Among its uses are:

- Laboratory and shop testing of paper and mica capacitors.
- Measurements of polarized electrolytic capacitors, including tantalytics, at 120 cps or 60 cps.
- Measurement of dielectric properties of solid insulation and transformer oil.
- In the electric power industry, for the shop testing of insulators and insulation, including bushings, transformers, rotating machines, and cable.
- For the wire and cable manufacturer, this bridge offers a convenient and rapid means for locating breaks in cable and for laboratory and production tests of dissipation factor and capacitance on all kinds of cable.
- The electronics industry will find it useful, not only for routine capacitance and dissipation factor tests on component capacitors,

but also for checking capacitance to ground of transformer windings, shields, and circuit elements.

**DESCRIPTION:** The circuit used is the series-resistance capacitance bridge. One ratio arm is continuously variable and calibrated to read directly in capacitance. The other ratio arm is variable in decade steps and serves as a multiplier for the direct-reading dial. The variable resistors in series with the standard capacitors are calibrated directly in dissipation factor.

A shield terminal is provided, to which a guard electrode or a ground terminal can be connected for 3-terminal measurements.

A visual null indicator is used, consisting of a tuned amplifier and an electron-ray tube. The entire instrument is ac operated.

For 60-cycle measurements, bridge power is derived directly from the power line. For 120-cycle measurements, an external oscillator, TYPE 1214-D is used. Other frequencies up to 1000 cps can also be used, if the detector filter is tuned externally.

A portable luggage-type carrying case houses the complete instrument.

### FEATURES:

- Wide range — 0 to 11,000  $\mu\text{f}$ .
- Measures either 2- or 3-terminal capacitors.
- Visual null indicator is an advantage in noisy locations.
- Detector sensitivity increases as balance point is approached, which greatly simplifies process of locating balance.
- Much less expensive than high-voltage equipment.
- Moderate external electrostatic fields do not affect accuracy.
- A dc polarizing voltage can be introduced from an external source.
- Measures polarized electrolytic capacitors under conditions of actual use — with 120-cycle ripple voltage applied.



### SPECIFICATIONS

**Capacitance Range:** 0 to 11,000  $\mu\text{f}$  at 60 cps. 1 to 11,000  $\mu\text{f}$  at 120 cps or other external frequency.

**Dissipation-Factor Range:** 0 to 60% at 60 cps. Range proportional to frequency. (0 to 120% at 120 cps.)

Dial readings must be multiplied by the ratio  $\frac{f}{60}$  for frequencies other than 60 cps.

**Accuracy:** Capacitance,  $\pm 1\%$ . Dissipation factor,  $\pm(2\%$  of dial reading  $+0.05\% \times \frac{f}{60}$  dissipation factor).

**Sensitivity:** Capacitances from 100 pf to 10,000  $\mu\text{f}$  can be balanced to a precision of at least 0.1%.

**Detector Filter:** Tuned to 60 or 120 cps, selected by switch. Jack provided for use of an external filter for other frequencies.

**External Generator:** Required for frequencies other than 60 cps. TYPE 1214-D Unit Oscillator listed below is recommended for 120-cycle measurements.

**External Fields:** For bushing testing, the fields usually encountered in shop and laboratory, even up to several thousand volts, will not affect the accuracy. For measurements in locations where the overhead voltages are very high, the unknown should be shielded.

**AC Voltage Applied to Capacitance under Test:** Varies from a maximum of approximately 125 volts at 100 pf to less

than 1 volt at 10,000  $\mu\text{f}$ . A maximum of one volt-ampere of reactive power is delivered to the sample. Voltage can be reduced by an external rheostat on the four highest ranges for measurement of tantalum capacitors.

**Polarizing Voltage:** An external de polarizing voltage of up to 500 volts can be applied for measurements on the four highest multiplier ranges. Terminals are provided.

**Temperature and Humidity Effects:** The readings of the bridge are unaffected by temperature and humidity variations over the range of room conditions normally encountered (18 to 35 C, 0 to 90% RH).

**Power Supply:** 105 to 125 (or 210 to 250) volts, 60 cps. A 50-cycle model is available; see price table below. Power input is 15 watts.

**Tube Complement:** One each 6X5-GT/G, 6SJ7, and 6U5.

**Accessories Supplied:** TYPE CAP-22 Three-Wire Power Cord and spare fuses.

**Other Accessories Required:** 120-cycle oscillator, if 120-cycle measurements are to be made. TYPE 1214-D Unit Oscillator is recommended.

**Mounting:** Luggage-type case, completely shielded to insure freedom from electrostatic pickup.

**Dimensions:** Width 14 $\frac{1}{4}$ , height 16, depth 10 inches (370 by 410 by 255 mm), over-all.

**Net Weight:** 30 $\frac{1}{2}$  pounds (14 kg).

TYPE		CODE WORD	PRICE
1611-B	Capacitance Test Bridge.....	FAVOR	\$650.00
1611-BQ1	Capacitance Test Bridge, for 50-cycle supply..	FAVORPASHA	700.00

## TYPE 1214-D UNIT OSCILLATOR

FOR 120-CYCLE MEASUREMENTS WITH TYPE 1611-B BRIDGE



ments of capacitance and dissipation factor in accordance with EIA standards. The output control is a four-position switch to provide four different output impedances, to match the TYPE 1611-B Bridge at each of its four 120-cycle multiplier settings, and is marked in terms of bridge multipliers.

A jack is provided for plugging in an external oscillator so that the output transformer and switching can be used at frequencies other than 120 cps.

Complete specifications for the TYPE 1214-D are given on page 106.

This oscillator drives the TYPE 1611-B Capacitance Bridge at 120 cps for measure-

TYPE		CODE WORD	PRICE
1214-D	120-cycle oscillator (including power supply).....	ABBOT	\$100.00





## TYPE 740-B CAPACITANCE TEST BRIDGE

RELIABLE, MODERATELY  
PRICED BRIDGE FOR  
SHOP AND LABORATORY



**USES:** The TYPE 740-B Capacitance Test Bridge is a 60-cycle capacitance and dissipation-factor bridge for use in both laboratory and production testing of paper, mica, and polarized electrolytic capacitors. The capacitor manufacturer can use it for production tests, the capacitor user for acceptance tests. It is particularly useful in testing polarized electrolytic capacitors, because the test conditions approximate the normal operating conditions of use.

**DESCRIPTION:** The circuit used in this instrument is that of a series-resistance capacitance bridge. One ratio arm is variable in decade steps, and the other is continuously variable and calibrated directly in capacitance.

The TYPE 740-B Capacitance Test Bridge

is a simpler instrument than the TYPE 1611-B, with a smaller capacitance range and lacking some of the features of the latter instrument.

**FEATURES:**

- Measures the direct capacitance of *un-grounded* capacitors. (Use TYPE 1611-B Bridge for grounded capacitors.)
- Visual null indicator makes the bridge useful for production testing in noisy locations.
- Simple to operate.
- Normal operating conditions for polarized electrolytic capacitors are reproduced by the use of a dc polarizing voltage. The ac voltage impressed by the bridge itself is small and simulates the ripple usually encountered in power-supply filters.

## SPECIFICATIONS

**Capacitance Range:** 5 pf to 100  $\mu$ f in seven ranges. Capacitance values are read directly from a logarithmic dial and multiplier switch.

**Dissipation-Factor Range:** 0 to 50% in two ranges. Scale has 50 divisions.

**Capacitance Accuracy:** Within  $\pm 1\%$  over the main decade (1 to 11) of the CAPACITANCE dial for all multiplier settings except .0001. Within  $\pm 1.5\%$  or  $\pm 3$  pf, whichever is the larger, on the .0001 multiplier on the main decade of the CAPACITANCE dial. Below 100 pf the error gradually increases to  $\pm 5$  pf as zero is approached.

**Dissipation Factor Accuracy:** Within  $\pm 1.5\%$  of full-scale reading for all capacitance multipliers except .0001.

On the .0001 capacitance multiplier a correction of 0.3% should be subtracted from the dissipation-factor dial reading. When this correction is made the accuracy is within  $\pm 2$  dial divisions on the x1 multiplier and within  $\pm 1$  division on the x10 multiplier.

**Voltage Applied to Unknown:** Varies continuously with the bridge setting from approximately 35 volts on the lowest range to approximately one volt on the highest range.

**Polarizing Voltage:** A dc polarizing voltage of up to 500 volts can be applied at panel terminals.

**Power Supply:** 105 to 125 (or 210 to 250) volts, 60 cps. The power input is 15 watts.

**Tube Complement:** One each 6X5GT/G, 6J7, 6E5.

**Accessories Supplied:** TYPE CAP-22 Three-Wire Power Cord, spare fuses.

**Mounting:** Luggage-type case.

**Dimensions:** Width 15, height  $14\frac{1}{2}$ , depth  $9\frac{1}{4}$  inches (385 by 370 by 235 mm), over-all.

**Net Weight:** 19 pounds (9 kg).

TYPE		CODE WORD	PRICE
740-B	Capacitance Test Bridge.....	BABEL	\$300.00





## TYPE 716-C CAPACITANCE BRIDGE

FOR THE PRECISE MEASUREMENT OF  
CAPACITORS AND DIELECTRIC MATERIALS

**USES:** This precise, direct-reading, capacitance bridge can be used for a wide variety of capacitance and dissipation-factor measurements. Within its scope are the determination of dielectric constant, dissipation factor, loss factor, phase angle, and other dielectric properties of insulating materials, as well as their change with such factors as frequency, temperature, and humidity.

In addition to direct-reading capacitance measurements, the bridge is capable of measuring other impedances by substitution methods. Among these are the inductance and storage factor of large inductors, up to several thousand henrys; the inductance and resistance of cables at frequencies up to 300 kc; the resistance and parallel capacitance of high-valued resistors, up to several thousand megohms; and capacitances up to several thousand microfarads.

By the addition of an external decade resistor, the bridge can be converted to either a series- or a parallel-resistance bridge; the latter is especially useful in measuring the resistance of electrolytes.

In the General Radio laboratories the TYPE 716 Capacitance Bridge is used for capacitance

standardization measurements. In production it is used for the testing and adjustment of precision fixed capacitors.

**DESCRIPTION:** The TYPE 716-C Capacitance Bridge is a modified Schering bridge, direct reading in capacitance from 30 cps to 300 kc, and in dissipation factor at 100 cps, and 1, 10, and 100 kc.

A wide capacitance range at 1 kilocycle is obtained by four sets of ratio arms giving multiplying factors from 1 to 1000 in decade steps. The built-in standard is a worm-driven variable precision capacitor, calibrated to read directly in total capacitance. All capacitances to ground of the input transformer and ratio arms are removed from the capacitance arms by enclosure in a shielded compartment insulated from the grounded panel and connected to the junction of the ratio arms.

Dissipation factor is indicated directly by the scale setting of an air capacitor and from a decade-step capacitor connected across the fixed ratio arm. The 12-inch scale of the air capacitor is approximately logarithmic, so that, while having a maximum reading of 0.06, its smallest division near zero is 0.0001,





thus allowing the estimation of 0.00002. The accuracy of the dissipation factor reading over the wide capacitance range is made possible by added capacitance across the lower-valued ratio arms, so that the product  $RC\omega M^*$  of all the ratio arms is the same.

### FEATURES:

- Wide capacitance and frequency ranges
- High accuracy
- Direct-reading dials
- Operation is simple, and both terminals and controls are arranged for convenience and flexibility of operation.
- Operation up to 300 kilocycles per second is made possible by careful design of the shielded transformer to minimize leakage impedances and dielectric losses.

\* Where M is the multiplier setting.

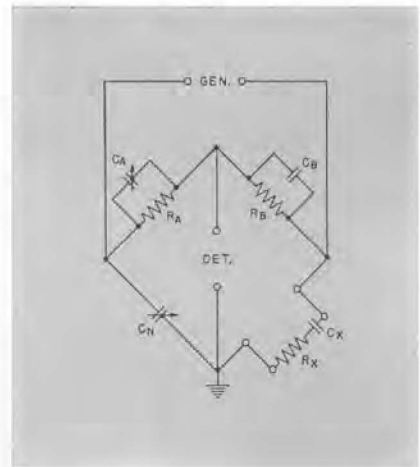

### SPECIFICATIONS

#### Ranges of Measurement

Capacitance, direct-reading: 100 pf to 1.1  $\mu$ f at 1 kc; 100 pf to 1150 pf at 100 cps, 10 kc, and 100 kc.

Capacitance, substitution: 0.1 pf to 1050 pf with the internal standard.

0.1 pf up to value of available standard with external standard.

Dissipation Factor, direct-reading: 0.00002 to 0.56.

Dissipation Factor, substitution:

$$0.00002 \text{ to } 0.56 \times \frac{C \text{ standard}}{C \text{ unknown}}$$

#### Accuracy

Capacitance, direct-reading:  $\pm 0.1\%$  ( $\pm 0.6 \text{ pf} \times \text{capacitance multiplier setting}$ ) when  $D < 0.01$ .

Capacitance, substitution:  $\pm 1.2 \text{ pf}$   
Dissipation Factor, direct reading:  $\pm 0.0005$  or  $\pm 2\%$  of dial reading, whichever is larger.

Dissipation Factor, substitution:  $\pm 0.00005$  or  $\pm 2\%$  for the change in  $D$  when the change is less than 0.06.

When  $D$  is greater than the limits given above, corrections must be made to maintain the stated accuracy. Formulae are supplied to make these corrections. A correction chart for the precision capacitor is also supplied which allows accuracy of substitution measurements of  $\pm 0.05\%$  or  $\pm 0.6 \text{ pf}$ . A 110-point calibration is available, at extra charge, which allows substitution measurements to be made with an accuracy of  $\pm 0.05\%$  or  $\pm 0.2 \text{ pf}$ .

**Frequency Range:** 30 cps to 300 kc. To maintain the accuracies stated above, the operating frequency must not differ from the range-selector frequency by more than a factor of three.

**Zero Capacitance Across the Unknown Terminals:** Ap-

proximately 1 pf (negligible in substitution measurements or direct measurements with the multiplier at 10 or higher).

**Temperature and Humidity:** Variations of temperature from 65 to 95 F have no significant effect on the accuracy of the bridge.

Precise measurements of dissipation factor should not be attempted when the bridge has been exposed to abnormally high relative humidity, unless it is first dried by heat or a desiccant.

**Power Input:** 1 watt, maximum, at GENERATOR terminals, which allows a maximum of 200 v at 1 kc, or 50 v at 60 cps. If the generator and detector connections are interchanged, 700 volts can be applied at 1 kc and lower.

**Accessories Supplied:** One TYPE 274-NL Shielded Patch Cord and one TYPE 874-R34 Patch Cord.

**Accessories Required:** Oscillator, high-impedance detector, and, for substitution measurements, a balancing capacitor. The TYPE 1210-C Unit RC Oscillator (page 102) is recommended with the TYPE 1232-A Null Detector (page 60) for measurements up to 100 kc. The TYPE 1302-A Oscillator (page 99) can also be used. At low radio frequencies, a radio receiver is a satisfactory detector. The TYPE 1422 Precision Capacitor and the TYPES 505, 1409, and 1401 Fixed Capacitors are recommended as balancing capacitors.

**Mounting:** Relay-rack mounting or hardwood cabinet.

**Dimensions:** Relay-rack model: width 19; height 14 inches (485 by 360 mm), depth behind panel 9 inches (230 mm). Cabinet model: width 21 $\frac{3}{4}$ ; height 14 $\frac{1}{4}$ ; depth 11 $\frac{1}{4}$  inches (555 by 365 by 290 mm).

**Net Weight:** Relay-rack model, 44 $\frac{1}{2}$  pounds (20.5 kg); Cabinet model, 54 $\frac{1}{2}$  pounds (25 kg).

TYPE		CODE WORD	PRICE
716-CR	Capacitance Bridge (Relay-Rack Model).....	BONUS	\$625.00
716-CM	Capacitance Bridge (Cabinet Model).....	BOSOM	655.00
	110-Point Calibration for Internal Precision Capacitor.....	WORMY	50.00

**TYPE 1610-B CAPACITANCE MEASURING ASSEMBLY:** A complete capacitance measuring assembly, including bridge, guard circuit, generator, and detector is listed on page 15.







## TYPE 716-P4 GUARD CIRCUIT

**USES:** The Guard Circuit facilitates the measurement of guarded dielectric samples and of other small capacitances where a three-terminal measurement is necessary. It is particularly useful in the measurement of components and materials over wide ranges of temperature and humidity, because it eliminates from the measurement the effects of the leads from the bridge to the sample in its conditioning apparatus and permits the same accuracy of measurement that would be obtained if the sample were positioned directly at the bridge terminals.

**DESCRIPTION:** See schematic. The guard arms *S* and *T* make it possible to balance any combination of capacitance and loss normally encountered in the terminal impedance of the unknown.

The circuit and switching are arranged for either direct reading or substitution methods. An 1150-pf variable balancing capacitor is built into the guard circuit



for substitution measurements and can be switched in or out of circuit, as required. Thus, the only external connection required is that to the unknown itself, for either direct-reading or substitution measurements.

### SPECIFICATIONS

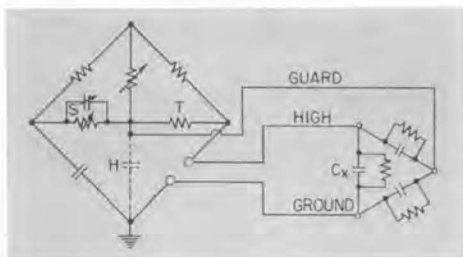

**Capacitance Range:** Designed for use with the x1 multiplier ranges of the TYPE 716-C Capacitance Bridge, i.e., a range of 0–1050 pf. The range can be extended by the addition of external capacitance to the standard arm of the bridge.

**Frequency Range:** Corresponds to that of TYPE 716-C.  
**Guard Balance Capacitor:** Any value of capacitance between up to 1000 pf can be balanced out.

**Accessories Supplied:** One TYPE 874-Q2 Coaxial Adaptor, One TYPE 838-B Alligator Clip.

**Net Weight:** TYPE 716-P4R, 17 pounds (8 kg); TYPE 716-P4M, 23 pounds (10.5 kg).

**Dimensions:** Width 19, height 9 $\frac{1}{8}$ , depth 8 $\frac{3}{4}$  inches (485 by 235 by 225 mm).

TYPE		CODE WORD	PRICE
716-P4M	Guard Circuit (Bench Model).....	BOSOMGUARD	\$350.00
716-P4R	Guard Circuit (Relay-Rack Model).....	BONUSGUARD	330.00

PATENT NOTICE. See Note 4, page viii.

## TYPE 1610 CAPACITANCE MEASURING ASSEMBLIES

### COMPLETE SYSTEMS FOR CAPACITANCE MEASUREMENT

**USES:** Each TYPE 1610 Capacitance Measuring Assembly is a complete set of equipment for highly precise measurement of capacitance and dissipation factor and for inter-comparison of capacitance standards. Measurements can be made by either direct or substitution methods.

The 1610-B Capacitance Measuring Assembly, which includes a guard circuit, can be used for three-terminals measurements and for measurements on samples some distance from the bridge.

For two-terminal measurements of dielectric constant and dissipation factor, the TYPE 1690-A Dielectric Sample Holder mounts directly on the capacitance bridge. Specimens of dielectric materials in the form of standard

ASTM 2-inch (or smaller) disks can be measured.

**DESCRIPTION:** Three models of the TYPE 1610 Capacitance Measuring Assemblies are available:

TYPE 1610-B, for two- and three-terminal measurements from 30 cps to 100 kc, includes:

- TYPE 716-C Capacitance Bridge
- TYPE 716-P4 Guard Circuit
- TYPE 1210-C Unit R-C Oscillator
- TYPE 1203-B Unit Power Supply
- TYPE 1232-A Null Detector

Cabinet rack, connecting cables, adaptor panels, and power cord.

TYPE 1610-B2, for two-terminal measurements from 30 cps to 100 kc, includes:





Type 1610-B

- TYPE 716-C Capacitance Bridge
- TYPE 1210-C Unit R-C Oscillator
- TYPE 1203-B Unit Power Supply
- TYPE 1232-A Null Detector

Cabinet rack, connecting cables, adaptor panels, and power cord.

TYPE 1610-AH, for two-terminal measure-

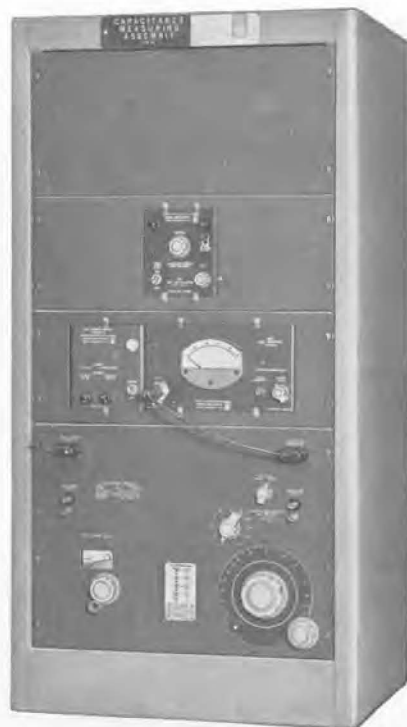

Type 1610-B2

ments at 1 Mc, includes:

- TYPE 716-CS1 Capacitance Bridge
- TYPE 1214-M Unit Oscillator
- TYPE 1212-A Unit Null Detector
- TYPE 1212-P2 One-Megacycle Filter
- TYPE 1203-B Unit Power Supply

Cabinet rack, connecting cables, adaptor panels, and power cord.

### SPECIFICATIONS

Abbreviated specifications are given below. For complete specifications see TYPE 716-C (page 13) for the TYPES 1610-B and 1610-B2, TYPE 716-CS1 (page 33) for the TYPE 1610-AH, TYPE 716-P4 (page 15), TYPE 1232-A (page 60), TYPE 1210-C (page 102), and TYPE 1214-M (page 106).

#### Ranges of Measurement

Capacitance: 0.1 to 1050 pf (to 1.1 $\mu$ f for 2-terminal measurements on Type 1610-B and -B2).

Dissipation Factor: 0.00002 to 0.56.

#### Accuracy

Capacitance, direct-reading:  $\pm 0.1\%$

Capacitance, substitution:  $\pm 1.2$  pf

Dissipation Factor:  $\pm 2\%$

#### Frequency Range

TYPES 1610-B and 1610-B2: 30 cps to 100 kc.

TYPE 1610-AH: 0.1 to 5 Mc, 1-Mc oscillator is supplied.

**Power Supply:** 105 to 125 volts, 50 to 60 cps, 100 watts at 115-v line. Assembly will operate satisfactorily on power-supply frequencies up to 400 cps, provided that the supply voltage is at least 115 volts.

**Accessories Supplied:** Necessary cables, adaptor, power cord, alligator clip, spare fuses.

**Dimensions:** Width 22 $\frac{1}{2}$ , height 43, depth 20 inches (570 by 1090 by 510 mm) over-all.

**Net Weight:** TYPE 1610-B, 203 pounds (92 kg); TYPE 1610-B2, 180 pounds (82 kg); TYPE 1610-AH, 150 pounds (69 kg).

TYPE		CODE WORD	PRICE
1610-B	Capacitance Measuring Assembly.....	SEDAN	\$1720.00
1610-B2	Capacitance Measuring Assembly (less Guard Circuit).....	SABER	1420.00
1610-AH	1-Mc Capacitance Measuring Assembly.....	SIREN	1035.00

PATENT NOTICE. See Notes 1, 2, and 4, page viii.





## TYPE 1690-A DIELECTRIC SAMPLE HOLDER

FOR MEASUREMENTS OF SOLID DIELECTRIC MATERIALS

**USES:** The TYPE 1699-A Dielectric Sample Holder is a micrometer-driven sample holder of the Hartshorn type,\* intended primarily for measurement of dielectric constant and dissipation factors of specimens of dielectric materials in the form of standard ASTM 2-inch diameter disks. It is suitable for any flat sample whose largest dimension is not greater than 2 inches and thickness not greater than 0.3 inch. It can be used, for example, with resonant circuits for susceptance-variation or frequency-variation measurements, with the TYPE 716-C and TYPE 716-CS1 Capacitance Bridges, the TYPE 874-LBA Slotted Line, and the TYPE 1602-B Admittance Meter.

**DESCRIPTION:** A precision micrometer screw drives the movable grounded electrode with respect to a fixed insulated electrode. The screw adjustment control is a large instrument knob, in contrast to the small thimble employed in the usual machinist's micrometer. Attached to the knob is an accurately divided drum which indicates the spacing between electrodes. The micrometer screw is electrically shunted by a metal bellows, assuring

positive low-resistance connection at all times. A release mechanism is incorporated in the design of the movable electrode, so that when full positive contact is made between the two electrodes, the drive disengages, thus protecting the mechanism against mechanical stress. When the surfaces of the specimen are not exactly parallel the movable electrode will adjust itself to the plane of the specimen surface.

A vernier capacitor with a capacitance range of 5 pf is also provided, for use in determining capacitance increments in the susceptance-variation method. This capacitor is of the cylindrical type, the movable cylinder being a precision micrometer screw. Ten turns of the screw cover the range of 5 pf, and the drum attached to the screw is accurately divided into 50 divisions, each corresponding to .01 pf.

The assembly is mounted in a rugged aluminum casting, which shields it on four sides. The shielding is completed by two removable cover plates, which permit access to the electrodes. The holder can be mounted on either horizontal or vertical panels.

For a more complete description of this instrument refer to the *General Radio Experimenter*, Volume 26, No. 3, August, 1951, and Volume 28, No. 1, June, 1953.

### FEATURES:

- A dielectric specimen can be measured over a wide range of frequencies with the same holder in different measuring circuits.
- Corrections for edge fringing and stray capacitance are taken care of by the calibration.
- Rigid casting supports entire structure.
- Large easily read dials.
- Complete shielding.
- Flexibility—can be used with a number of different bridges or other measuring circuits.
- Precision calibration provided for each holder.
- "Floating" electrode protects precision drive.

\*L. Hartshorn and W. H. Ward, Proceedings of the Institution of Electrical Engineers, vol 79, pp 597-609 (1936).



### SPECIFICATIONS

**Electrodes:** Diameter, 2.000 inches  $\pm 0.0025$  inch. Surfaces are ground optically flat within a few wavelengths.

**Electrode Spacing:** Adjustable from zero to 0.3-inch indicated by the micrometer reading in mils.

**Vernier:** Incremental capacitance is 5 pf, nominal.

**Calibration:** For the main capacitor, a chart is provided giving the calculated air capacitance as a function of spacing. A correction curve is also provided with each holder, giving the measured deviations from calculated values over the range from 300 mils to 10 mils spacing. In accordance with recommended ASTM practice, this calibration is referred to the calculated geometric value at a spacing of 100 mils. Accuracy is  $\pm 0.2\%$   $\pm 0.1$  mil.

For the vernier capacitor, a correction chart is provided, from which capacitance differences can be determined to an accuracy of  $\pm 0.004$  pf.

**Zero Capacitance:** Approximately 11 pf.

**Operating Temperature:** Up to 150 C.

**Frequency:** No significant error occurs at frequencies below 100 Mc. At higher frequencies satisfactory results can be obtained for many types of measurements.

**Accessories Supplied:** TYPE 1690-P1 Adaptor Assembly for mounting to the TYPES 716-C and -CS1 Capacitance Bridges. Hardware is supplied for mounting sample holder on TYPES 740-B, 1611-B, 544-B Bridges and TYPE 1862-B Megohmmeter.

**Accessories Available:** TYPE 1690-P2 Adaptor Assembly for connecting to TYPE 874-LBA Slotted Line or TYPE 1602 Admittance Meter.

**Mounting:** Supplied with a wooden carrying case. A drawer in the case provides storage for hardware, and a spring clip holds the calibration charts.

**Dimensions:** Mounted on adaptor,  $6\frac{3}{4}$  by  $5\frac{3}{4}$  by  $4\frac{1}{2}$  inches (160 by 150 by 115 mm), over-all.

**Net Weight:**  $3\frac{3}{4}$  pounds (1.8 kg).

TYPE		CODE WORD	PRICE
1690-A	Dielectric Sample Holder.....	LOYAL	\$435.00
1690-P2	Adaptor Assembly (for connection to coaxial equipment).....	LOYALMOUNT	20.00

PATENT NOTICE. See Note 4, page viii.





## TYPE 1613 CAPACITANCE BRIDGE

TYPE 1613-A — TEST SET, CAPACITANCE BRIDGE, TTU 24/E,  
PRECISION, THREE-TERMINAL, DEPOT  
TYPE 1613-K — 1-KC, THREE-TERMINAL CAPACITANCE BRIDGE

**USES:** This is an excellent capacitance bridge for precise, three-terminal measurements. The TYPE 1613-A 400-cycle model is basically a calibrator for the capacitive fuel-gage testers<sup>1</sup> that check the accuracy of aircraft fuel-quantity gages. It meets the essential requirements of specifications MIL-T-4778 (USAF) and has been given the militarily assigned commercial-standard designation TTU 24/E, as listed above. The TYPE 1613-K model is a similar bridge which operates at 1 kilocycle per second.

**DESCRIPTION:** The circuit is that of a transformer bridge, with an ingenious method for making the dissipation-factor dial direct-reading. The inductively coupled ratio arms are in the detector circuit, so that the voltage on the unknown capacitor remains constant as the bridge ratio is changed. The direct impedance of the T network used in the standard side of the bridge balances the direct

impedance of the unknown. The balance equations are:

$$C_X = C_A (M)$$

$$\text{and } D_X = \omega R (C_A + C_B)$$

where  $M$  is a multiplier of 1 or  $\frac{1}{10}$  (as selected) and  $C_X$  is the series capacitance of the unknown.

The sum  $(C_A + C_B)$  is kept constant, so that  $R$  is proportional to  $D_X$  and is therefore directly calibrated in dissipation factor. Other transformer-type capacitance bridges require a computation to obtain this quantity.

The standard capacitor, which forms the differential unit consisting of  $C_A$  and  $C_B$ , is actually a 50-to-1100 pf variable air unit and a 1000-to-10,000 pf decade of silvered-mica capacitors. The sum  $(C_A + C_B)$  is kept constant by the addition of an extra set of stator plates to a worm-driven, variable, precision capacitor, and by differential switching of the mica units. On the  $\times \frac{1}{10}$  range the lower

<sup>1</sup> General Radio TYPE 1429-A, page 171, is this type of device

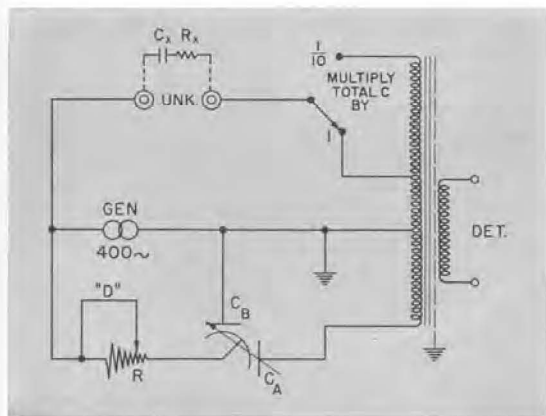

Schematic diagram of Type 1613-A Capacitance Bridge.

limit is extended down by a factor of  $\frac{1}{10}$ , so that the over-all range becomes 5 to 11,000 pf.

The oscillator is thermistor stabilized and uses a Wien-bridge selective  $RC$  network in a three-stage feedback circuit, which has such a high loop gain that the frequency is practically independent of tube parameter changes. The frequency-determining components are GR precision resistors and capacitors. A buffer cathode-follower amplifier is added to prevent external loading from affecting the frequency.

### FEATURES:

- Rapid and accurate balancing.
- High selectivity.
- Panel lights indicate direction of capacitance unbalance to simplify measurement procedure.
- Easy to operate — few balance controls.
- No guard circuit is necessary for three-terminal measurements.

### SPECIFICATIONS

#### Ranges of Measurement

Capacitance: 5 to 11,000 pf.  
Dissipation Factor: 0 to 0.11.

#### Accuracy

Capacitance:  $\pm 0.1\%$  from 11,000 to 40 pf, rising to 0.8% at 5 pf.  
Dissipation Factor:  $\pm 2\%$  of reading  $\pm 0.0002$ .

#### Internal Oscillator Frequency

TYPE 1613-A: 400 cps.  
TYPE 1613-K: 1 kc.  
Oscillator output is 25 volts, nominal.

**Detector Sensitivity:**  $\times 1$  MULTIPLIER position — 10% deflection for .05 pf  $\Delta C$ .

$\times \frac{1}{10}$  MULTIPLIER position — 10% deflection for .005 pf  $\Delta C$ .

#### Detector Selectivity

TYPE 1613-A: Down 44 db at 800 cps, down 72 db at 60 cps.

TYPE 1613-K: Down 44 db at 2 kc.

**Effect of Impedance to Third Terminal (Chassis):** Impedance from the unshielded lead to chassis shunts the oscillator and, therefore, causes no bridge error. The output voltage is reduced approximately 50% by shunt impedance of 5 k $\Omega$  or 0.1  $\mu f$  on the TYPE 1613-A or of 5 k $\Omega$  or .02  $\mu f$  on the TYPE 1613-K.

Impedance from the coaxial lead to chassis shunts the bridge transformer. On the  $\times 1$  MULTIPLIER position, there is negligible effect from a shunt of 1 k $\Omega$  or 0.1  $\mu f$  on the TYPE 1613-A or of 1 k $\Omega$  or .02  $\mu f$  on the TYPE 1613-K. On the  $\times \frac{1}{10}$  MULTIPLIER position, there is negligible effect from 10 k $\Omega$  or .01  $\mu f$  on the TYPE 1613-A or of 10 k $\Omega$  or .002  $\mu f$  on the TYPE 1613-K.

**Accessories Supplied:** For connection to TYPE 1429-A Fuel Gage Tester, two unshielded cable assemblies and one common shielded assembly; for connection to TYPE 03 Fuel Gage Tester, one cable harness, including termination unit assembly; for general-purpose three-terminal measurements, one coaxial and one unshielded cable

assembly, with TYPE 874 connectors. Power cord is also supplied.

**Tube Complement:** 5-5751; 1-12AT7WA; 1-6X4WA.

**Power Supply:** 105 to 125 volts, 50-60 cps. 30 watts input at 115-volt line.

**Dimensions:** Width 22 $\frac{1}{2}$ , height 14, depth 12 $\frac{3}{4}$  inches (575 by 360 by 325 mm), over-all, including cover.

**Net Weight:** 55 pounds (25 kg).

For a more complete description of this instrument refer to the *General Radio Experimenter*, Volume 32, No. 9, February, 1958.



View of Type 1613-A Capacitance Bridge showing cabinet with cover in place.

TYPE		CODE WORD	PRICE
1613-A	Capacitance Bridge, 400-cps model.....	SUPER	\$2175.00
1613-K	Capacitance Bridge, 1000-cps model.....	SULLY	2375.00





## TYPE 1632-A INDUCTANCE BRIDGE

PRECISE BRIDGE FOR STANDARDIZATION OF INDUCTORS

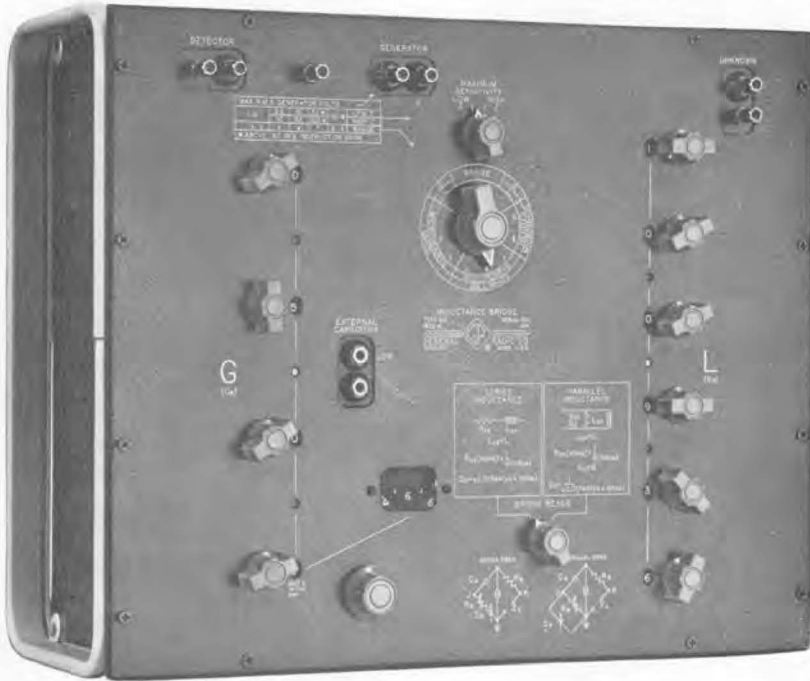

**USES:** The TYPE 1632-A Inductance Bridge is designed for the precise measurement of either the series or the parallel components of two-terminal grounded inductors, at audio frequencies, over a wide range of inductance. Its high accuracy makes it suitable for standardization measurements, while its convenient in-line readout feature and the absence of a sliding balance make possible rapid measurements of high precision.

Measurement of incremental inductance can be made at low levels of ac and dc excitation.

**DESCRIPTION:** The Owen circuit used in this bridge is shown schematically in the accompanying diagram. In this circuit, the standard reactance is a capacitor, which, owing to its very low residual impedances, exhibits a negligible change in its effective capacitance over the audio range. The Owen circuit also makes possible the use of the high accuracy of decade resistors for the inductance balance. The decades can be switched to either a series or a parallel connection, so that the bridge can be made direct reading in either series or parallel components of the unknown inductor. Over a wide range of  $Q$ , the unknown can be measured

in terms of whichever components are most convenient.

Inductance is indicated by the setting of a six-decade control; conductance by the setting of four decades and a variable air capacitor. The inductance dials, which show only the pertinent digit of each decade, indicate directly either series or parallel inductance. Resistance, either series or parallel, is the reciprocal of the conductance setting. An eight-position multiplier automatically indicates both the decimal point and the units for both inductance and conductance.

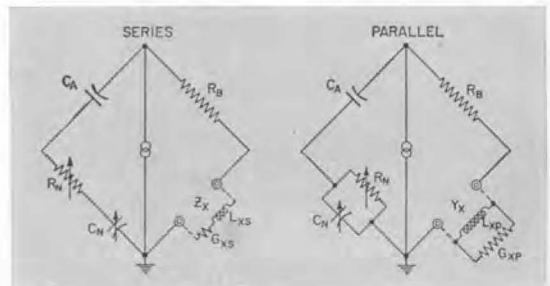

Elementary schematic of bridge configuration for series and parallel inductance measurement.



To obtain maximum accuracy for the measurement of both large and small values of inductance, the residual impedances associated with the "unknown" terminals have been minimized.

### FEATURES:

- Extremely wide range, 0.0001  $\mu$ h to 1111 h.
- $\pm 0.1\%$  direct-reading accuracy.
- High resolution — six significant figures.
- Will detect 0.1 millimicrohenry.
- Easy, fool-proof readout with in-line decade readings and indicated decimal points.
- No sliding balance.
- Measures series or parallel inductance.
- Instructions, equations, and circuits engraved on the panel.



The Type 1632-A Inductance Bridge is shown in a laboratory set-up for the measurement of standard inductors.

### SPECIFICATIONS

#### Ranges of Measurement

**Inductance:** 0.0001  $\mu$ h to 1111 h.

**Conductance:** 0.0001  $\mu$ mho to 1111 mhos.

#### Accuracy

**Inductance:**  $\pm 0.1\%$ , direct-reading. This accuracy is reduced at the extremes of the inductance,  $Q$ , and frequency ranges. The lowest inductance range (0.0001 to 111  $\mu$ h) has a direct-reading accuracy of  $\pm 1\%$ .

When the  $Q$  of the unknown is less than unity, the accuracy is reduced to  $(+0.05 \pm Q_B)\% / Q_X$ . Values of  $Q_B$  at 1 kc (the phase angles of the compensated  $R_B$  resistors) are given in the table.

Range	a, b, c	d-Low Z	e-High Z	f-Low Z	g	h
$R_B$	1 $\Omega$	10 $\Omega$	100 $\Omega$	1k $\Omega$	10 k $\Omega$	100 k $\Omega$
$Q_B$ at 1kc	$\pm 0.3\%$	$\pm 0.05\%$	$\pm 0.02\%$	$\pm 0.02\%$	$\pm 0.2\%$	$\pm 0.1\%$

For frequencies higher than 1 kc, the error can be determined from the above expression with the  $Q_B$  values multiplied by the frequency in kilocycles. There is an additional error of  $0.1 \times 10^{-8} f^2\%$  on the lowest inductance range and of  $4 \times 10^{-8} f^2\%$  on the highest range.

Two nearly equal inductors can be intercompared to a precision of one part in  $10^5$  or better.

The bridge adds approximately 1 pf to the capacitance across the inductor.

**Conductance:**  $\pm 1\%$  direct-reading accuracy. This accuracy is reduced at the extremes of the  $L$  and  $G$  decades, of  $Q$ , and of frequency. The  $C_N$  capacitor decades are adjusted within  $\pm 1\% + 2$  pf.

When the  $Q$  of the unknown is greater than 10, the error, when the bridge reads either series resistance

or parallel conductance, is increased to  $Q_X (=0.05 \pm Q_B)\%$ . See the table above for values of  $Q_B$  at 1 kc.

For frequencies above 1 kc, the value of  $Q_B$  is multiplied by the frequency in kilocycles.

When the bridge reads series resistance, there is an additional error of 0.15  $Q_X\%$  at 1 kc and with the  $L$  decades set at one-tenth full scale ( $R_N = 10$  k $\Omega$ ). This error is proportional to frequency (with constant  $Q_X$ ) and approximately proportional to the resistance ( $R_N$ ) of the  $L$  decades.

**Maximum Measurable Q:** For series connection, proportional to frequency, 60 at 100 cps. For parallel connection, 80 at 100 cps and  $R_N$  of 100,000 ohms, inversely proportional to frequency and to  $R_N$ .

**Maximum Safe Bridge Input Voltage:** One volt on low-inductance ranges to 100 volts on high ranges. Values are engraved on the panel.

**Accessories Required:** Generator and detector. The TYPE 1304-B Beat-Frequency Audio Generator (page 100) or the TYPE 1210-C Unit R-C Oscillator (page 102) with the TYPE 1206-B Unit Amplifier (page 64) and the TYPE 1232-A Null Detector are recommended (page 60).

**Accessories Supplied:** Two TYPE 274-NL Shielded Patch Cords for connection to generator and detector, TYPE 1632-P1 Transformer to match low bridge-input impedances to generators which require a 600-ohm load.

**Mounting:** Aluminum cabinet and panel with end frames. Can also be relay-rack mounted.

**Dimensions:** Width 19½, height 16, depth 10½ inches (495 by 410 by 270 mm), over-all; depth behind panel 8½ inches (230 mm).

**Net Weight:** 40 pounds (18½ kg).

For a more complete description of this instrument refer to the *General Radio Experimenter*, Volume 33, No. 11, November, 1959.

TYPE	CODE WORD	PRICE
1632-A	Inductance Bridge.....	BARGE
		\$950.00

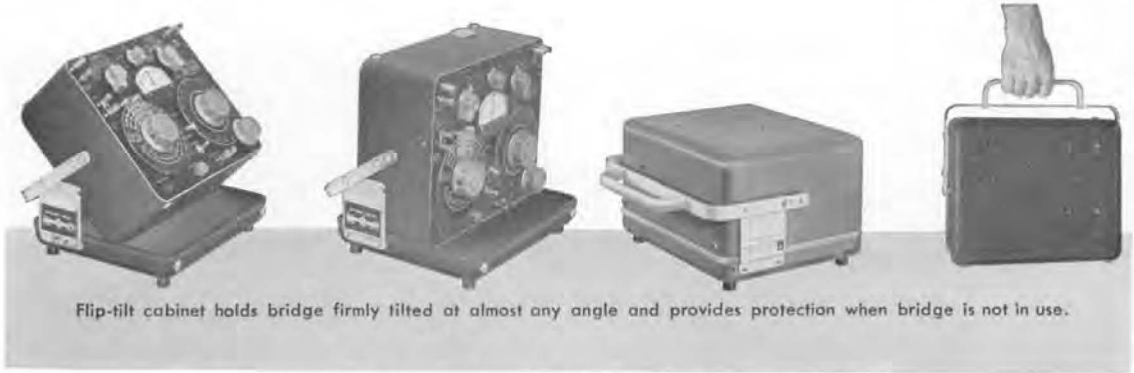

Flip-tilt cabinet holds bridge firmly tilted at almost any angle and provides protection when bridge is not in use.

## TYPE 1650-A IMPEDANCE BRIDGE

### COMPLETELY SELF-CONTAINED UNIVERSAL BRIDGE

**USES:** The TYPE 1650 Impedance Bridge will measure the inductance and storage factor,  $Q$ , of inductors\*, the capacitance and dissipation factor,  $D$ , of capacitors, and the ac and dc resistance of all types of resistors.

In the laboratory it is extremely useful for measuring the circuit constants in experimental equipment, testing preliminary samples, and identifying unlabeled parts. In the shop and on the test bench it has many applications for testing and component sorting.

Three-terminal measurements can be made in the presence of considerable stray capacitance to ground.

**DESCRIPTION:** This bridge is a completely self-contained and portable instrument. Five separate bridge circuits are included to give

\* Including such low- $Q$  inductors as rf coils measured at 1 kc.

flexibility and wide range. Battery-powered, low-drain transistor oscillator and detector are included. The panel meter indicates both dc and ac bridge unbalances, and, therefore, headphones are not required.

The measured quantities,  $R$ ,  $L$ ,  $C$ ,  $D$ , and  $Q$ , are indicated directly on dials with logarithmic scales. No multiplier is necessary for the  $D$  and  $Q$  indications and the  $C$ ,  $R$ , or  $L$  multipliers and the units of measurement are indicated by the range switch setting.

The bridge circuits are made up of high-quality, stable components to give accuracy for many years under a wide range of conditions. *Orthonull*, a patented mechanical-ganging device is used to make low- $Q$  (high- $D$ ) balances possible without a "sliding null". This mechanism, which may be switched in or out as desired, adds accuracy as well as convenience and makes easy many low- $Q$  measurements that are practically impossible on other impedance bridges.

The design provides a handle and a captive, protective cover and allows the bridge panel to be tilted and held firmly at any angle.

#### FEATURES:

- Completely self-contained and portable.
- Wide impedance range, covering all common components.
- *Orthonull* to facilitate low- $Q$  balances.
- Meter indication of ac as well as dc unbalances, so that headphones are not necessary.
- Transistor oscillator and detector powered by common "D" cells.
- Provision for applying dc to components being measured.
- Easy-to-read dials.
- Excellent  $D$  and  $Q$  accuracy.
- Very small residual errors.
- Long battery life; easy replacement.







### SPECIFICATIONS

- Ranges**  
**Resistance:** 1 mΩ to 10 MΩ, 8 ranges ac or dc.  
**Capacitance:** 1 pf to 1000 μf, 7 ranges, series or parallel.  
**Inductance:** 1 μh to 1000 h, 7 ranges, series or parallel.  
**D:** (of series capacitance): 0.001 to 1 at 1 kc (of parallel capacitance): 0.1 to 50 at 1 kc ( $C_s = C_p$  within 1% if  $D < 0.1$ )  
**Q:** (of series inductance): 0.02 to 10 at 1 kc (of parallel inductance): 1 to 1000 at 1 kc ( $L_s = L_p$  within 1% if  $Q > 10$ )
- Accuracy**  
**Resistance\*:** ±1% ±1 mΩ (residual  $R = 1$  mΩ)  
**Capacitance:** ±1% ±1 pf (residual  $C = 0.5$  pf)  
**Inductance:** ±1% ±1 μh (residual  $L < 0.2$  μh)  
**D:** ±5% ±0.001 at 1 kc or lower  
**1/Q:** ±5% ±0.001 at 1 kc or lower
- Frequency Range:** (1 kc supplied internally)  
 1% accuracy for R, 20 cps to 5 kc; for L and C, 20 cps to 20 kc. D and Q ranges are functions of frequency.  
**Internal Oscillator Frequency†:** 1 kc ±2%.
- Internal Detector:** Response, flat or selective at 1 kc; sensitivity control provided.  
**Internal DC Supply:** 6 v, 60 ma max.  
**Power Supply:** 4 D cells, supplied. Current drain (ac measurements) 10 ma.  
**External Oscillator and Detector:** TYPE 1210-C Unit R-C Oscillator (page 102) and TYPE 1232-A Null Detector (page 60) are recommended for audio measurements.  
**DC Polarization:** 600 volts may be applied (from external source) for series capacitance measurements.  
**Accessories Available:** TYPE 1650-P1 Test Jig.  
**Other Accessories Required:** None. Headphones may be used for high precision at the extremes of the bridge ranges.  
**Mounting:** Aluminum cabinet, with captive cover.  
**Dimensions:** Width 12 3/4, height 12 1/2, depth 7 3/4 inches (325 by 320 by 200 mm), over-all, including handle.  
**Net Weight:** 17 pounds (8 kg).  
 For a more complete description of this instrument send for General Radio Reprint No. E-108.

TYPE		CODE WORD	PRICE
1650-A	Impedance Bridge.....	BATON	\$450.00

PATENT NOTICE. See notes 1, 19 and 22, page viii.  
 \* For dc resistance, accuracy is 1% from 1Ω to 100kΩ. An external

DC Supply is required for 1% accuracy above 100 kΩ.  
 † External ac and dc sources can also be used.

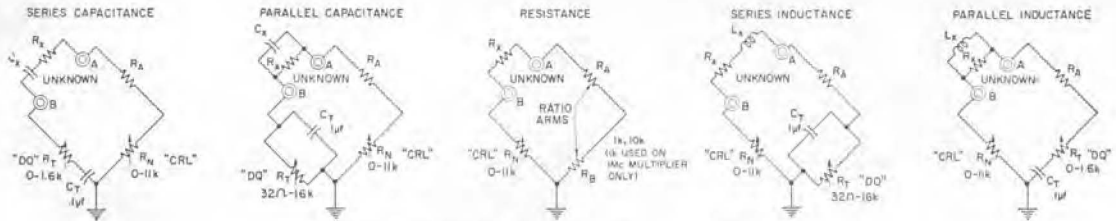

Schematic diagrams of the five circuits used in the bridge.

## TYPE 1650-P1 TEST JIG

### MINIMIZES EFFECTS OF LEAD CAPACITANCE

This test-jig adaptor provides a way to connect components quickly to a pair of terminals, which can be placed on the bench directly in front of the operator. Thus, the test jig and 1650-A Bridge make a rapid and efficient component sorting device when the panel meter of the 1650-A is used as a limit indicator.

The test jig makes a three-terminal connection to the bridge, so that the residual zero capacitance is negligible. The lead resistance (0.08 ohm total) has effect only when very low impedances are measured, and the lead capacitance affects only the measurement of the  $Q$  of inductors, introducing a small error in  $D$  (or  $\frac{1}{Q}$ ) of less than 0.007.



Test jig makes three-terminal connection to the Type 1650-A Impedance Bridge for rapid connection and measurement of components.

TYPE		NET WT	CODE WORD	PRICE
1650-P1	Test Jig.....	10 oz	LOCAL	\$19.00





## TYPE 1603-A Z-Y BRIDGE

### A UNIVERSAL AUDIO-FREQUENCY IMPEDANCE-MEASURING INSTRUMENT

**USES:** This remarkable bridge can easily be balanced for *any* impedance connected to its terminals and belongs in *any* laboratory where impedance measurements are made. For example, the TYPE 1603-A Z-Y Bridge can be used to measure:

- R, L, and C components, or any combinations of them,
- Reactance-resistance curves for electro-acoustic transducers,
- Open- and short-circuit transformer characteristics,
- Frequency characteristics of electrolytic capacitors,
- Resonances of inductors and transformers,
- Complex input, output, and characteristic impedances of transmission networks,
- Transistor input and output impedances,
- Characteristics of sonar elements,
- Conductivity of liquids,
- Circular-arc plots of solids and liquids in electrochemical research.
- Negative resistance of active circuits.

**DESCRIPTION:** The basic circuit is the familiar resistance-capacitance bridge. An initial balance is made without the unknown element, and then a final balance with the unknown in the circuit. The difference in control settings between these two balances is the value of the unknown.

Low impedances are measured directly in terms of R and X, and high impedances, i.e. low admittances, are measured directly in terms of G and B. *Any* value of unknown can be balanced as either an impedance or admittance.

R and G readings are independent of frequency. X and B readings are direct at 100 cps, 1 kc, and 10 kc. At other frequencies, X must be divided, and B multiplied, by the ratio

$$\frac{\text{operating frequency}}{\text{reference frequency}} = \frac{f}{f_0}$$

The controls and switching of the TYPE 1603-A Z-Y Bridge provide the utmost in convenience of operation. The unknown is always connected to a single pair of terminals



for impedance or admittance measurement for both initial and final balances. The main selector switch connects the unknown internally for either impedance or admittance measurement and disconnects it during the initial balance.

The reference-frequency switch may be used as a multiplier for the  $X$  and  $B$  ranges when it is set to a value other than nearest the actual operating frequency.

By selection of detector connections, one can measure (1) the grounded, (2) the direct or (3) the total delta value, balanced or unbalanced, of the unknown element — a valua-

ble ability not possessed by most other instruments.

### FEATURES:

- Will balance for any unknown.
- Covers entire audio-frequency range.
- 1% accuracy for both real and imaginary components to 7 kc.
- Reads directly in ohms or micromhos.
- Fast, convenient operation.
- Can measure grounded, direct, or balanced impedances or admittances.

### SPECIFICATIONS

**Frequency Range:** 20 cps to 20 kc.

**Impedance and Admittance Range:**  $-\infty$  to  $+\infty$ .

The unknown is measured as an impedance if the absolute resistance is less than 1000 ohms and the absolute reactance is less than 1000 ( $f/f_0$ ) ohms.

The unknown is measured as an admittance if the absolute conductance is less than 1000 micromhos and the absolute susceptance is less than 1000 ( $f/f_0$ ) micromhos.

Under certain limited conditions, a choice of  $Z$  or  $Y$  measurements is possible.

**Accuracy** (for measurements with the unknown grounded)

**R:**  $\pm 1\%$

$\pm 2\Omega$  main  $R$  dial, or  $\pm 0.2\Omega$   $\Delta R$  dial

$\pm 0.0002(f/f_0)(X)$

**X:**  $\pm 1\%$  ( $\pm 2\%$  above 7 kc,  $\pm 3\%$  above 15 kc)

$\pm 2(f_0/f)\Omega$  main  $X$  dial, or  $\pm 0.2(f_0/f)\Omega$   $\Delta X$  dial

$\pm 0.0002(f/f_0)R$

**G:**  $\pm 1\%$

$\pm 2$   $\mu$ hos main  $G$  dial, or  $\pm 0.2$   $\mu$ ho  $\Delta G$  dial

$\pm 0.0002(f/f_0)B$

**B:**  $\pm 1\%$  ( $\pm 2\%$  above 7 kc,  $\pm 3\%$  above 15 kc)

$\pm 2(f/f_0)$   $\mu$ hos main  $B$  dial, or  $\pm 0.2(f/f_0)$   $\mu$ ho  $\Delta B$  dial

$\pm 0.0002(f/f_0)G$

These specifications apply to measurements made with the unknown grounded. There are slightly larger errors at high frequencies for direct or delta measurements.

**Maximum Applied Voltage:** 130 volts rms on bridge, less than 32 volts on unknown.

**Accessories Required:** Calibrated oscillator or suitable generator and detector. The TYPE 1210-C Unit Oscillator (page 102) is recommended. TYPE 1232-A Null Detector (page 60) is recommended.

**Accessories Supplied:** One TYPE 274-NP and one TYPE 874-R34 Patch Cords.

**Mounting:** Aluminum cabinet and panel. Carrying handle provided.

**Dimensions:** Width 12½, height 13½, depth 8½ inches (320 by 345 by 220 mm), over-all.

**Net Weight:** 21½ pounds (10 kg).

For a more complete description of this instrument send for the General Radio Reprint No. E-102.

TYPE		CODE WORD	PRICE
1603-A	Z-Y Bridge.....	CATER	\$450.00

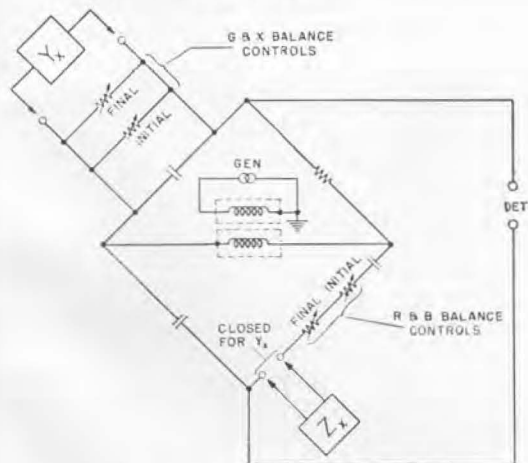

Elementary schematic diagram of the Type 1603-A Z-Y Bridge.

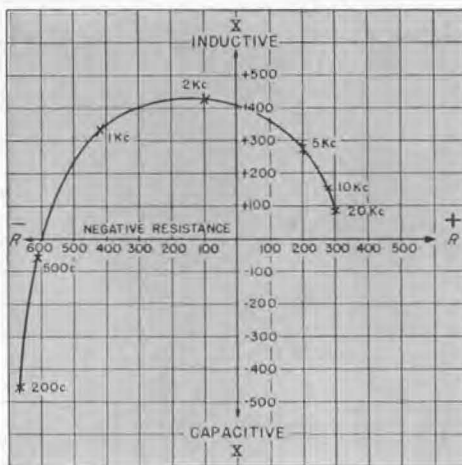

Input impedance of a feedback circuit; data taken with Type 1603-A Z-Y Bridge.





## TYPE 1605-A IMPEDANCE COMPARATOR

ACCURATE AND VERSATILE ON THE PRODUCTION LINE AND  
 IN THE LABORATORY

**USES:** Typical uses for this highly precise instrument include:

- Rapid testing, sorting, and matching of precision components, etched boards, subassemblies and complex networks, either manually or in combination with automatic sorting equipment.
- Measuring the effects of time, temperature, humidity, and pressure on components, with high precision and continuous indication.
- Rapid test for tracking of ganged potentiometers and variable capacitors.
- Frequency characteristics of components.
- Easy comparison of quantities usually requiring laboratory techniques, such as:
  - Small impedance differences.
  - $D$  of low-loss dielectric materials.
  - $D$  of inductors.
  - $Q$  or phase angle of wire-wound resistors or potentiometers.
  - Balance of transformer windings.
  - Transistor capacitances.

**DESCRIPTION:** This completely self-contained impedance comparator indicates directly on two panel meters the difference in impedance and phase angle between a pair of elements connected to its terminals. Three highly desirable characteristics not usually obtained together are combined in this unique instrument:

- high accuracy
- high speed
- wide ranges of impedance and frequency.

As a result, not only does it bring laboratory accuracy to production-line inspection, but, conversely, it brings the speed of the produc-

tion test to measurements in the laboratory.

The basic circuit of the comparator is a bridge circuit, with the unknown and standard impedances serving as two of the bridge arms and the halves of a center-tapped transformer secondary winding serving as the other two arms. An internal R-C oscillator driving the transformer primary winding provides frequencies at 100 cps, 1 kc, 10 kc, and 100 kc. The bridge unbalance voltage, resulting from inequality of standard and unknown impedances, is separated into in-phase and out-of-phase components, which are amplified and indicated directly by two meters reading, respectively, impedance magnitude difference in percent and phase-angle difference in radians.

The transformer is especially designed to

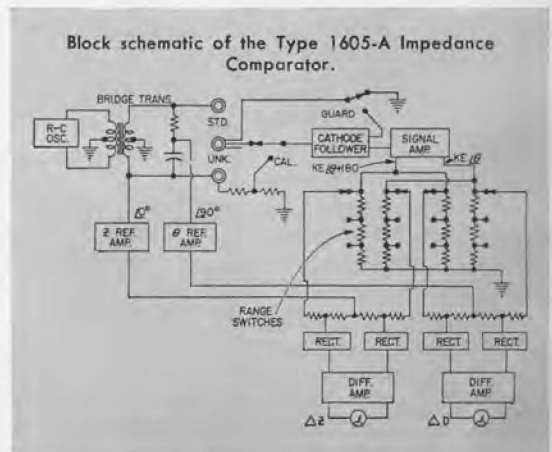



have as high a degree of coupling as possible between the two halves of its secondary winding. The coefficient of coupling achieved is greater than 0.9997, and the open-circuit voltages of the two halves are balanced to within 1 part in  $10^6$ . This makes possible measurement of differences as low as .01% on the TYPE 1605-A and .003% on the TYPE 1605-AH and minimizes the loading effect of external impedances on the bridge transformer.

An unusual type of cathode-follower circuit provides a very high input impedance for the bridge detector and also a guard terminal. This shield makes possible the measurement of high impedances at a distance from the instrument, as in an environmental test chamber.

For operating external selector circuits, meter voltages are available at the rear of the instrument; a plug connector is supplied.

Calibration can quickly be checked at any time by means of a simple built-in network.

### FEATURES:

- High-speed meter indication: no balancing operation required.
- Wide frequency range: 100 cps to 100 kc.
- High accuracy.
- Versatile: compares impedances of any phase angle.
- Wide impedance range: 2 ohms to 20 megohms.
- Compares both magnitude and phase angle simultaneously and indicates direction of unbalance.
- Guard point available.
- Completely self-contained.
- Meter terminals are brought out at rear for operation of automatic selection devices or recorder.
- Meters are protected so that the instrument need not be externally shorted between measurements to prevent off-scale damage.

### SPECIFICATIONS

#### Ranges of Measurement

	R or  Z	C	L
1605-A	2 Ω to 20 MΩ	40 pf to 800 μf*	20 μh to 10,000 h
1605-AH	20 Ω to 20 MΩ	40 pf to 80 μf	200 μh to 10,000 h

\* to 0.1 pf with reduced accuracy.

#### Meter Ranges

##### Type 1605-AM, -AR

**Impedance Magnitude Difference:** ±0.3%, ±1%, ±3%, ±10%, full scale. (Can be adjusted for maximum of 50%.)

**Phase Angle Difference:** ±0.003, ±0.01, ±0.03, ±0.1 radian, full scale. The phase angle difference is very nearly equal to the D difference for capacitors or inductors, or the Q difference for resistors, as long as the D or Q is less than 0.1.

##### Type 1605-AHM, -AHR

**Impedance Magnitude Difference:** ±0.1%, ±0.3%, ±1%, ±3%, full scale.

**Phase Angle Difference:** ±0.001, ±0.003, ±0.01, ±0.03 radian, full scale.

**Accuracy of Difference Readings:** 3% of full scale; i.e., for the ±0.3% impedance-difference scale, accuracy is 0.009% of the impedance magnitude being measured.

**Voltage Across Standard and Unknown:** TYPE 1605-A, approximately 0.3 volt; TYPE 1605-AH, 1 volt.

**Tube Complement:**

1-5651	5-12AT7
1-5751	3-6U8
3-12AX7	1-6AS7G
4-6AL5	1-3A10

**Power Supply:** 105 to 125 (or 210 to 250) volts, 50 to 60 cps; about 100 watts input at 115 volts. Instrument will operate satisfactorily on power-supply frequencies

up to 400 cps, provided that the supply voltage is at least 115 volts.

**Accessories Supplied:** TYPE CAP-22 Three-Wire Power Cord, telephone plug, external-meter plug, adaptor plate assembly (fits panel terminals), spare fuses.

**Mounting:** Relay-rack panel with cabinet; TYPE 1605-AR and -AHR have fittings to permit either instrument or cabinet to be removed from rack without disturbing the other; TYPE 1605-AM and -AHM have end supports for table or bench use.

**Dimensions:** Width 19, height 7, depth 13½ inches (485 by 180 by 345 mm), over-all; depth behind panel 12 inches (305 mm).

**Net Weight:** 29½ pounds (13.5 kg).

For a more complete description of this instrument see for General Radio Reprint No. E-103.



TYPE		CODE WORD	PRICE
1605-AM	Impedance Comparator (bench mounting).....	GIPSY	\$800.00
1605-AR	Impedance Comparator (relay-rack mounting)...	GUNNY	800.00
1605-AHM	Impedance Comparator (bench mounting).....	DENSE	925.00
1605-AHR	Impedance Comparator (relay-rack mounting)...	DEVOR	925.00

PATENT NOTICE. See Notes 4 and 15, page viii. Models with other meter ranges or other frequencies are available on special order.





## TYPE 1661-A VACUUM-TUBE BRIDGE

FOR MEASUREMENTS OF  
OPERATING PARAMETERS OF  
VACUUM TUBES AND TRANSISTORS



**USES:** The TYPE 1661-A Vacuum-Tube Bridge makes possible the measurement of the low-frequency dynamic coefficients of vacuum tubes and transistors over very wide ranges of values and under a wide variety of operating conditions.

For vacuum tubes, independent, direct-reading measurements of voltage-amplification factor, resistance, and transconductance can be made quickly and easily.

For transistor applications, within the range and sensitivity of the bridge one can determine the short-circuit conductance parameters  $g_i$ ,  $g_o$ ,  $g_r$ , and  $g_f$  as well as the  $h_r$  and  $h_i$  parameters directly. Some open-circuit parameters can be measured if careful external shielding is provided where required. The  $h_{fe}$  ( $\alpha$ ) and  $h_{fc}$  ( $\beta$ ) parameters as well as the open-circuit impedance parameters can be calculated from the short-circuit conductance measurements.

Although not intended for the service-testing of tubes and transistors, the vacuum-tube bridge is more than adequate for the rugged job of production testing, and it is a most accurate device for evaluating tube coefficients and most transistor low-frequency parameters.

In development and research, this instrument affords a means of studying the behavior of tubes and transistors used in unconventional and special circuits, where any one of

the electrodes may be used as the control electrode and where the parameters may have negative values.

The circuits have large enough current-carrying capacity and sufficient insulation so that many transmitting tubes can be tested in addition to receiving tubes and transistors.

**DESCRIPTION:** The bridge makes use of alternating-current null methods of measurement, in which phase-shift and capacitance errors have been given special consideration in order that the operating range of the bridge may be as wide as possible. Each of the three coefficients is obtained in terms of the ratio of two alternating test voltages. A third voltage is employed in the capacitance balancing circuit, but its value does not enter into the results.

An extremely flexible arrangement of the control circuits makes it possible to measure the resistance, voltage ratio, and transconductance parameters referred to any pair of electrodes. Connections from the tube or transistor under test to the measuring circuit are made by means of coaxial cables and jacks connected to a nine-terminal jack plate mounted on the panel. Unused cables can be secured to or grounded to the panel. Sixteen coaxial plugs are mounted on the panel, permitting a wide variety of interconnections between the jack plate, the measuring circuit, and external power supplies.



Twelve adaptor plates for plugging in tubes and transistors (see specifications) are provided.

In this latest version of the Vacuum-Tube Bridge, selection of either of two internal resistance standards permits operation at a bridge ratio that yields improved sensitivity at the resistance and transconductance extremes.

A switch permits the independent testing of each section of twin (two-identical-section) tubes, without the need for reconnecting patch cords.

Self-bias resistors can be connected for either single- or two-section tubes.

The operating frequency can be 270–400 cps or 1000 cps.

### FEATURES:

- A simple and straightforward measurement procedure is used and is exactly the same for all three coefficients. At balance, the quantity being measured is indicated directly to three figures by bridge dial settings.
- Independent measurements of the three main tube parameters are possible, i.e., none of the balances depends in any way on any other.
- Negative values of the coefficients can be measured as readily as positive values.
- The transconductance of a tube having a high value of grid-to-plate capacitance can be measured without error from this capacitance.
- Low-frequency parameters of transistors can be measured.

Simplified diagram of the circuit employed for the measurement of transconductance with the Type 1661-A Vacuum-Tube Bridge. The points of introduction of the test voltages  $e_1$  and  $e_2$  are changed by a switch when the other coefficients are measured. Another switch reverses the polarity of  $e_1$  when negative values of the coefficients are to be measured.

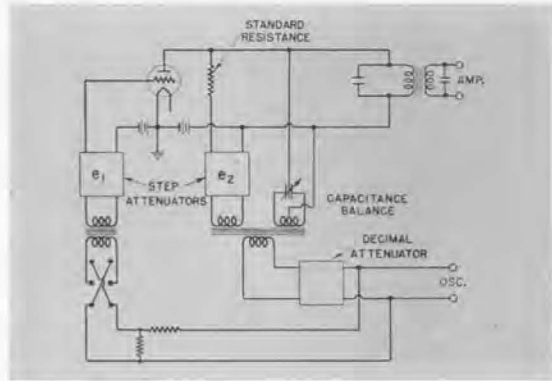

### SPECIFICATIONS

**Range:** Amplification factor ( $\mu$ ), 0.001 to 10,000.

Dynamic internal plate resistance ( $r_p$ ), 50 ohms to 20 megohms.

Transconductance ( $g_m$ ), 0.02 to 50,000 micromhos.

Under proper conditions, the above ranges can be exceeded. The various parameters can also be measured with respect to various elements, such as screen grids, etc. Negative as well as positive values can be measured.

**Accuracy:** Within  $\pm 2\%$  for resistances ( $r_p$  switch position) from 1000 to 1,000,000 ohms. At lower and higher values the error increases.

The expression  $\mu = r_p g_m$  will check to  $\pm 2\%$  when the quantities are all measured by the bridge, and when  $r_p$  is between 1000 and 1,000,000 ohms.

**Frequency:** 270 to 400 cps, or 1000 cps.

**Tube and Transistor Mounting:** Adaptors are provided for 3- and 4-lead transistors and for tubes of 4-pin, 5-pin, 6-pin, small 7-pin, large 7-pin, octal, loctal, miniature button 7-pin, miniature button 9-pin (noval), acorn (5- and 7-pin), flat-press subminiature up to 7 wires, and 8-wire subminiature. In addition, a universal adaptor, with nine soldering lugs, is provided so that unbased transistors, unmounted tubes, or tubes with nonstandard bases, can be measured conveniently. For short lead subminiature tubes, for nuvistors, and for transistors, sockets are supplied which can be mounted on the universal adaptor. Thus all standard commercial receiving tubes and transistors can be measured. The panel jack

plate and the adaptors are made of low-loss (natural) phenolic, reducing to a minimum the shunting effect of dielectric losses on the dynamic resistance being measured.

**Current and Voltage Ratings:** Maximum allowable plate current, 400 ma; maximum plate voltage, 1500 volts.

**Electrode Voltage Supply:** Batteries or other suitable power supplies are necessary for providing the various voltages required by the device under test.

**Bridge Source:** TYPE 1214-A Oscillator (page 106) is recommended.

**Null Detector:** The TYPE 1232-A Tuned Amplifier and Null Detector (page 60) and the TYPE 1212-A Unit Null Detector (page 61) is recommended.

**Accessories Supplied:** Adaptors and sockets as listed above, all necessary plug-in leads, and shielded patch cords for connecting generator and detector, adaptor case.

**Mounting:** The instrument is mounted in a hardwood cabinet. A wooden storage case is provided for the adaptors and leads. Storage space is provided for a spare universal adaptor, on which any type of socket can be permanently mounted.

**Dimensions:** Width  $15\frac{3}{4}$ , length 20, depth 11 inches (400 by 510 by 280 mm), over-all.

**Net Weight:** TYPE 1661-A weighs 40 pounds (18.5 kg). The accessories supplied and the accessory box weigh 14 pounds (6.5 kg).

TYPE		CODE WORD	PRICE
1661-A	Vacuum-Tube Bridge.....	BEIGE	\$1100.00



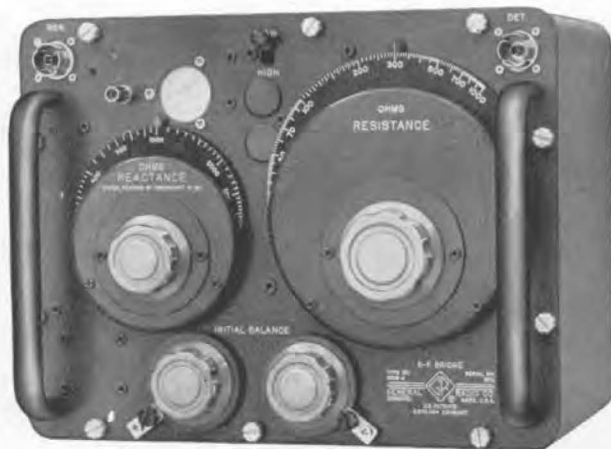

**TYPE 1606-A RADIO-FREQUENCY BRIDGE**  
FOR THE MEASUREMENT OF ANTENNAS, LINES, NETWORKS  
AND COMPONENTS FROM 400 KC TO 60 MC

**USES:** The TYPE 1606-A Radio-Frequency Bridge measures impedances simply and accurately at frequencies from 400 kc to 60 Mc. It measures directly the resistance and reactance of antennas, transmission lines, networks, and components. Although designed primarily for measuring the low values of impedance most often encountered in rf devices, its range can be extended by means of an external parallel capacitor so as to measure high impedances, such as tuned circuits.

**DESCRIPTION:** The bridge circuit used is shown schematically in the diagram below. Measurements are made by a series-substitution method. The components of the unknown impedance are determined from the change in settings of capacitors  $C_A$  and  $C_P$ . The un-

known reactance at 1 Mc is read directly in ohms from the dial of  $C_P$ , and the unknown resistance in ohms from the dial of  $C_A$ .

In making measurements the bridge is first balanced by means of capacitors  $C_P$  and  $C_A$  with a short-circuit across the unknown terminals. The short is then removed, the unknown impedance connected, and the bridge rebalanced. The resistance is then given by

$$R_x = R_B \frac{(C_{A2} - C_{A1})}{C_N}$$

and the reactance by

$$X_x = \frac{1}{\omega} \left( \frac{1}{C_{P2}} - \frac{1}{C_{P1}} \right)$$

where the subscripts 1 and 2 denote the dial readings for the initial and final balances respectively.

The resistive component is measured in terms of a *fixed* resistor ( $R_B$ ), a fixed capacitor ( $C_N$ ), and a variable capacitor ( $C_A$ ). This feature is an important factor in the high-frequency performance of the bridge because residual parameters can be made much smaller in a fixed resistor and a variable capacitor than in a variable resistor.

The TYPE 1606-A Bridge incorporates several important features in bridge design. A *single, internal bridge transformer*, used to couple an external generator to the bridge circuit, covers the entire 150:1 frequency range of the instrument while its triple shield-

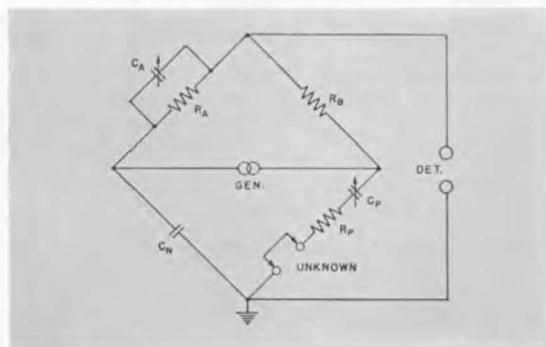





ing keeps undesired couplings to an insignificant level. A *special type of variable air capacitor*, having very low losses and inductance, is used for the reactance balances and the initial resistance balance. In this capacitor the complete rotor and stator sections are milled out of solid blocks of aluminum, a construction that avoids losses at the joints between plates and spacers and provides the utmost stability. Finally, the entire mechanical design is such that *the instrument can operate under difficult environmental conditions* similar to those specified for testing military electronics equipment, which makes the TYPE 1606-A Bridge an excellent instrument for portable field use.

### FEATURES:

- High accuracy and reliability.
- Fast, simple operation.
- Wide frequency range.
- Measures most impedances directly.
- Small, light, and rugged for field use — carrying case available.
- Initial balance controls have locks to prevent accidental movement.

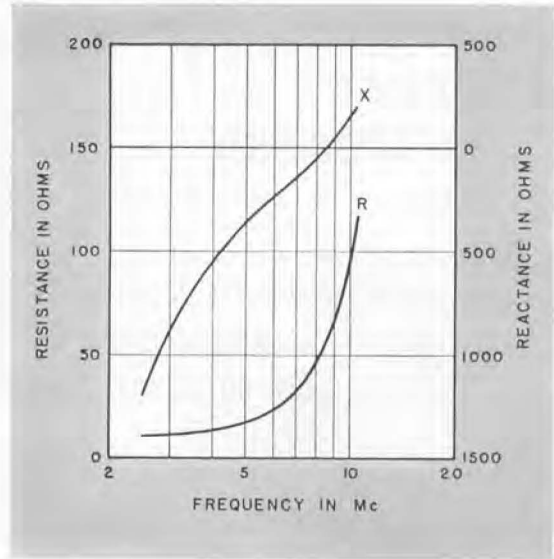

Reactance and resistance of an antenna system measured with the Radio-Frequency Bridge.

### SPECIFICATIONS

**Frequency Range:** 400 kc to 60 Mc.  
**Reactance Range:**  $\pm 5000\Omega$  at 1 Mc. This range varies inversely as the frequency; and at other frequencies the dial reading must be divided by the frequency in megacycles.  
**Resistance Range:** 0 to  $1000\Omega$ .  
**Accuracy:** For reactance at frequencies up to 50 Mc,  $\pm(2\% + 1\Omega + 0.0008 \times R \times f)$ , where  $R$  is the measured resistance in ohms and  $f$  is the frequency in Mc.

For resistance, at frequencies up to 50 Mc,  

$$\pm \left[ 1\% + 0.0021f^2 \left( 1 + \frac{R}{1000} \right) \% \pm \frac{10^{-1} X}{f} \Omega + 0.1\Omega \right]$$
 subject to correction for residual parameters.  $R$  is the measured resistance in ohms,  $X$  is the measured reactance in ohms, and  $f$  is the frequency in Mc. At high frequencies, the correction depends upon the frequency and magnitude of the unknown resistance component. A chart from which the correction can be determined is given in the instruction book supplied with the bridge.  
 Satisfactory operation can be obtained at frequencies as low as 100 kc and somewhat above 60 Mc with not quite as good accuracy as indicated above. The  $f^2$  term is important only at frequencies above 10 Mc. The  $1/f$  term is important only at very low frequencies when the resistance of a high-reactance, low-loss capacitor is measured.

**Terminals:** Generator and detector terminals are Type 874 Coaxial Connectors. Adaptors to all commonly used coaxial connectors are available (see page 42).

**Accessories Supplied:** Two leads of different lengths for connecting the unknown impedance to the bridge terminals, one  $\frac{1}{2}$ -in. spacer and one  $\frac{3}{4}$ -in., 6-32 screw for two Type 874-R22 Coaxial Cables for connecting the generator and detector, and one Type 874-PB58 Panel Connector.

**Other Accessories Required:** Radio-frequency generator and detector. The Type 1330-A Bridge Oscillator and the Type 1211-B Unit Oscillator are satisfactory generators, as are the Type 1001-A and the Type 805-C Standard-Signal Generators. At frequencies above 50 Mc a Type 1215-B Unit Oscillator or a Type 1021-AV Standard-Signal Generator is recommended. See pages 85-113.

A well-shielded communications receiver covering the desired frequency range makes a satisfactory detector. It is recommended that the receiver be fitted with the Type 874-PB58 Panel Connector or other coaxial connector to avoid leakage at the input connection.

**Mounting:** Welded aluminum cabinet supplied. A luggage-type carrying case is available separately.

**Dimensions:** Width  $12\frac{1}{2}$ , height  $9\frac{1}{2}$ , depth  $10\frac{1}{4}$  inches (320 by 245 by 260 mm), over-all.

**Net Weight:** 23 pounds (10.5 kg) without carrying case; 29 pounds (13.5 kg) with carrying case.

For a more complete description of this instrument refer to the General Radio Experimenter, Volume 30, No. 1, June, 1955.

TYPE		CODE WORD	PRICE
1606-A	Radio Frequency Bridge*	CIGAR	\$660.00
1606-P1	Luggage-Type Carrying Case	BILLY	17.50

\* PATENT NOTICE. See Notes 4 and 12, page viii.





## TYPE 916-AL RADIO-FREQUENCY BRIDGE

FOR THE MEASUREMENT OF ANTENNAS  
LINES, NETWORKS, AND COMPONENTS  
AT FREQUENCIES FROM 50 KC TO 5 MC

**USES:** The TYPE 916-AL Bridge measures impedances quickly and accurately at frequencies from 50 kc to 5 Mc. It measures directly the resistance and reactance of antennas, transmission lines, networks, and components. Although designed primarily for measuring the low values of impedance most often encountered in its frequency range, its impedance range can be extended by means of an external parallel capacitor so as to measure high impedances, such as tuned circuits.

**DESCRIPTION:** The circuit is similar to that of the TYPE 1606-A R-F Bridge used at higher



frequencies (see page 30). Two transformers are used to cover the entire frequency range, the lower limit of which can be extended down to 15 kc for many measurements.

### FEATURES:

- High accuracy and reliability.
- Fast, simple operation.
- Measures most impedances directly.
- Suitable for field use.
- $\Delta X$  dial permits measurement of large capacitances and small inductances.

### SPECIFICATIONS

**Frequency Range:** 50 kc to 5 Mc. Satisfactory operation for many measurements can be obtained at frequencies as low as 15 kc.

**Reactance Range:**  $\pm 11,000\Omega$  at 100 kc. This range varies inversely as the frequency, and at other frequencies the dial readings must be divided by the frequency in hundreds of kc. To facilitate the measurement of small reactances, the instrument is provided with an incremental reactance dial which has a range of 100 ohms at 100 kc.

**Resistance Range:** 0 to 1000 $\Omega$ .

**Accuracy:** For reactance at frequencies up to 3 Mc,  $\pm (2\% + 0.2 \times \frac{100}{f_{kc}} \Omega + 3.5f_{kc}R \times 10^{-10})$  where  $R$  is the measured resistance in ohms and  $f_{kc}$  is the frequency in kc. The errors in reactance increase relatively rapidly at frequencies above 3 Mc; and at 5 Mc the accuracy is  $\pm (2\% + 0.01\Omega + 2.3R^{1/2} \times 10^{-3})$ .

For resistance, at frequencies up to 5 Mc,  $\pm (1\% + 0.1\Omega)$ , subject to correction for residual parameters at low frequencies. The correction depends upon the frequency and upon the magnitude of the unknown reactance component. A plot of this correction is given in the instruction book supplied with the bridge.

**Accessories Supplied:** Two input transformers, one covering the lower portion of the frequency range, the other the higher portion; two leads of different lengths (for connecting the unknown impedance); two TYPE 874-R22 Coaxial Cables for connecting generator and detector; one TYPE 874-PB58 Panel Connector.

**Other Accessories Required:** Radio-frequency generator and detector. The TYPE 1330-A Bridge Oscillator (page 107) and the TYPE 1211-B Unit Oscillator (page 108) are satisfactory generators as are the TYPE 1001-A and the TYPE 805-C Standard Signal Generators (pages 88 and 86). A well-shielded radio receiver covering the desired frequency range makes a satisfactory detector. It is recommended that the receiver be fitted with the TYPE 874-PB58 Panel Connector (page 41) supplied to avoid leakage at the input connection.

**Mounting:** Luggage-type. Both input transformers are stored inside the case. Coaxial cables, leads, and instruction book are stored in the cover of the instrument when not in use.

**Dimensions:** Width 13 $\frac{1}{2}$ , height 17, depth 11 $\frac{1}{4}$  inches (345 by 435 by 290 mm), over-all.

**Net Weight:** 34 $\frac{1}{2}$  pounds (16 kg).

TYPE		CODE WORD	PRICE
916-AL	Radio-Frequency Bridge	CLUCK	\$670.00

PATENT NOTICE. See Notes 4 and 12, page viii.



# TYPE 716-CS1 CAPACITANCE BRIDGE

FOR CAPACITANCE  
MEASUREMENTS AT  
1 MEGACYCLE

Both commercial and military specifications for capacitors of 1000 pf and less call for measurements of capacitance and dissipation factor at a frequency of 1 Mc. The TYPE 716-CS1 Capacitance Bridge has been designed specifically for these measurements. This bridge, a modification of the standard TYPE 716-C model, has unity ratio arms, a single capacitance range, and a limited frequency range.

The standard capacitor is designed for use at 1 Mc. and above, and the input transformer is designed for high-frequency operation.

In addition to its use in testing capacitors, the TYPE 716-CS1 Capacitance Bridge is satisfactory for measuring dielectrics with the TYPE 1690-A Dielectric Sample Holder at the ASTM test frequency of 1 Mc.

## SPECIFICATIONS

### Ranges of Measurement

- Capacitance, direct-reading: 100 to 1150 pf.
- Capacitance, substitution: 0.1 to 1050 pf.
- Dissipation Factor, direct-reading: 0.00002 to 0.56.

Dissipation Factor, substitution:  $0.00002 \times \frac{C_{\text{standard}}}{C_{\text{unknown}}}$   
 to  $0.56 \times \frac{C_{\text{standard}}}{C_{\text{unknown}}}$

### Accuracy

- Capacitance, direct-reading:  $\pm 0.1\% \pm (0.6 \text{ pf} \times \text{capacitance multiplier setting})$  when  $D < 0.01$ .
- Capacitance, substitution:  $\pm 1.2 \text{ pf}$ .
- Dissipation Factor, direct-reading:  $\pm 0.0005$  or  $\pm 2\%$  of dial reading, whichever is larger.
- Dissipation Factor, substitution:  $\pm 0.00005$  or  $\pm 2\%$  for the change in  $D$  when the change is less than 0.06.

The stated accuracy is for 1-Mc measurements. The same accuracy can be obtained from 0.1 Mc to 3 Mc if corrections are made for the effects of residual impedances and if adequate selectivity is provided by the null detector.

**Frequency Range:** Calibrated for 1 Mc, the bridge operates

satisfactorily at frequencies between 0.1 and 5 Mc.

**Accessories Required:** Generator and detector. For measurement at one megacycle only, the TYPE 1214-M Unit Oscillator (page 106) is the recommended generator; for measurements over the range of 0.5 to 3 Mc, the TYPE 1211-B Unit Oscillator with Unit Power Supply (page 108); other oscillators and standard-signal generators are also satisfactory. For the detector at 1 Mc the TYPE 1212-A Unit Null Detector (page 61) with TYPE 1212-P2 One-Megacycle Filter and Unit Power Supply is recommended. For operation at frequencies other than 1 Mc, a well-shielded communications receiver should be used.

For substitution measurements, a balancing capacitor is needed. This may be a fixed TYPE 505, 1409, or 1401 Capacitor or a variable TYPE 1422 Precision Capacitor (pages 158-166).

**Accessories Supplied:** Two TYPE 874-R34 Cables, to fit generators and detectors recommended above.

**Other Accessories Available:** For measurements on unguarded dielectric specimens, the TYPE 1690-A Dielectric Sample Holder (page 17) is recommended.

Other specifications are the same as those for the standard TYPE 716-C.

TYPE		CODE WORD	PRICE
716-CMS1	Capacitance Bridge (Cabinet Model).....	BOGEY	\$600.00
716-CRS1	Capacitance Bridge (Relay-Rack Model).....	BACON	575.00
	110-Point Calibration for Internal Precision Capacitor.....	WORMY	50.00

**TYPE 1610-AH CAPACITANCE MEASURING ASSEMBLY:** A complete assembly, including bridge, generator, detector, and relay rack is listed on page 15.





## TYPE 1602-B U-H-F

## ADMITTANCE METER

A UNIQUE INSTRUMENT FOR UHF-VHF  
ADMITTANCE, IMPEDANCE, AND VSWR  
MEASUREMENT FROM 40 TO 1500 MC

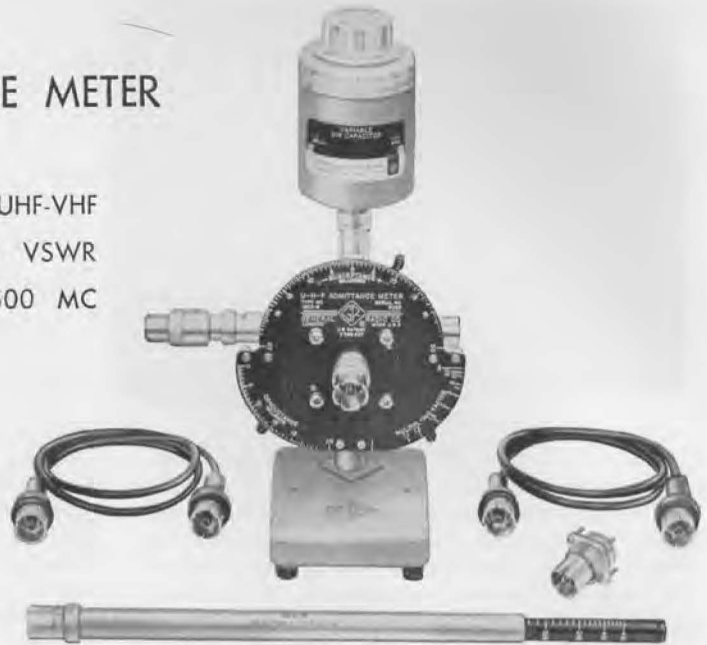

**USES:** The Admittance Meter is a null-type instrument for determining the components of an unknown admittance in the vhf-uhf range. It is particularly useful for measurements on coaxial systems: antennas, lines, coaxial components, etc. It can be used as an indicator for adjusting a network to a predetermined admittance or for matching one network to another and is particularly useful in matching antennas and other networks to 50-ohm circuits.

As a comparator, the Admittance Meter can be used to determine impedance magnitude, reflection-coefficient magnitude, and voltage standing-wave ratio.

The usefulness of the Admittance Meter is greatly enhanced by the many accessories available for use with it. Among these are:

The TYPE 874-LK20 Constant Impedance Adjustable line, which can be set to one-half wavelength to eliminate corrections for the length of transmission line between the unknown and the measuring point. When the line is set to one-quarter wavelength, the Admittance Meter dials read directly in *impedance* parameters, i.e., the series resistance and reactance of the unknown.

The TYPE 874-UB Balun, for use in measuring balanced impedances, such as TV receiving antennas and transmission lines.

The TYPE 874-M Component Mount, which provides a convenient means of connecting

lumped elements (resistors, capacitors, or inductors) to the Admittance Meter for measurement.

Adaptors for most types of military connectors and for rigid vhf and uhf transmission lines used with TV transmitting antennas. With these adaptors and the adjustable line mentioned above, the over-all accuracy of measurement is more than adequate for antenna measurements in design, test, and installation.

**DESCRIPTION:** The TYPE 1602-B Admittance Meter comprises a coaxial line to which the unknown is connected, a shielded pickup loop to sample the current, a second line and loop terminated in a pure resistance, and a third line and loop terminated in a pure reactance. All are fed from the same voltage source, so that their input voltages are in phase, and the current in each line is proportional to the admittance. The voltage induced in each loop is proportional to the current in the corresponding line and is dependent upon the orientation of the loop, which is adjustable.

The three loops are connected in parallel, and the voltage from the loop in the unknown line is canceled by adjustment of the loops coupled to the standard lines until a null is reached. The conductance and susceptance of the unknown are read directly from the scales of the standard loops, while the scale of the loop in the unknown line indicates the multiplying factor.



Admittance Meter set up for VSWR measurements on a coaxial switch.

### FEATURES:

- Dial scales are direct-reading, independent of frequency.
- No sliding balance; real and reactive adjustments are independent.
- No initial balance is necessary.
- Wide frequency range — direct-reading from 40 to 1500 Mc; can be used at frequencies as low as 20 Mc.
- Covers completely both vhf and uhf television bands.
- Accurate, rapid, and easy to use.
- Can be used with TYPE DNT Detector to measure VSWR directly.

### SPECIFICATIONS

**Range:** Theoretically, zero to infinity; practically, the lower limit is determined by the smallest readable increment on the scale, which is 100 micromhos (0.1 millimho). The upper limit is 1000 millimhos. Range is the same for both conductance and susceptance, but susceptance can be either positive or negative, i.e., the susceptance dial is calibrated from -20 to +20 millimhos. Multiplying factors from 1 to 20 are provided, and factors from 20 to 100 can be determined approximately.

VSWR as high as 10 can be readily measured by a voltage-ratio method. For standing-wave ratios less than 1.2, VSWR can be measured by a direct-reading method in which the magnitude is determined from the meter reading of a TYPE DNT Detector without adjustment of the Admittance Meter controls.

**Accuracy:** For both conductance and susceptance (up to 1000 Mc).

from 0 to 20 millimhos  $\pm(3\% \pm 0.2 \text{ millimho})$

from 20 to  $\infty$  millimhos  $\pm(3\sqrt{M}\% \pm 0.2 \text{ millimho})$  where M is the scale multiplying factor. Above 1000 Mc, errors increase slightly, and, at 1500 Mc, the basic figure of 3% in the expression above becomes 5%. For matching impedances to 50 ohms, the accuracy is 3% up to 1500 Mc.

**Frequency Range:** 40 to 1500 Mc, direct-reading. Range can be extended downward to 20 Mc, if a frequency correction is applied to the susceptance reading.

**Accessories Supplied:** Two TYPE 1602-P4 50- $\Omega$  Termination, for use as conductance standards, and one TYPE 1602-P1 Adjustable Stub and one TYPE 1602-P3 Variable Air Capacitor, for susceptance standards; two TYPE S74-R22 Patch Cords for connections to generator and detector; and one TYPE S74-PB58 Panel Connector for installation on detector. A wooden storage case is furnished.

**Other Accessories Required:** Generator and detector. Generator should cover desired frequency range and deliver between 1 volt and 10 volts. TYPE 1208-B (65 to 500 Mc), TYPE 1215-B (50 to 250 Mc), TYPE 1209-B (250 to 920 Mc) and TYPE 1218-A (900 to 2000 Mc)

Unit Oscillators (pages 110-112) and the TYPE 1361-A Oscillator (page 109), are recommended. The TYPE 1021-AU and -AV Generators are also satisfactory.

Detector sensitivity should be better than 10 microvolts. TYPE DNT Detectors (page 58) are recommended.

**Other Accessories Available:** Coaxial adaptors (page 42); line stretcher (page 46); balun (page 51); and component mount (page 43); Smith charts (page 55).

**Terminals:** All terminals are TYPE S74 Coaxial Connectors. Adaptors are available for other coaxial systems (page 42).

**Dimensions:** Width 5½, height 7½, depth 5½ inches (140 by 195 by 140 mm), without standards or unknown.

**Net Weight:** 8¼ pounds (3.8 kg).

For a more complete description of this instrument refer to the *General Radio Experimenter*, Volume 28, No. 3, August, 1953 and Volume 34, No. 5, May, 1960.

Schematic diagram of admittance meter circuit, with standards, generator, and null detector connected for admittance measurements.

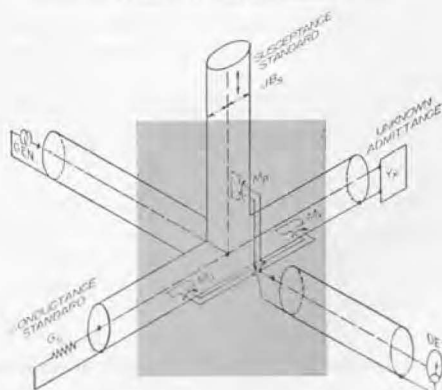

TYPE	CODE WORD	PRICE
1602-B   U-H-F Admittance Meter.....	HONEY	\$295.00

PATENT NOTICE. See Note 4, page viii.

**OTHER COAXIAL IMPEDANCE-MEASURING DEVICES:** TYPE 1607-A Transfer-Function and Imittance Bridge (page 36); TYPE S74-LBA Slotted Line (page 52).





Instrument with Transfer-Function Indicator mounted in place. Storage box with accessories is shown above.



**TYPE 1607-A**  
**TRANSFER-FUNCTION AND IMMITTANCE BRIDGE**  
25 TO 1500 MC

**USES:** The Transfer-Function and Immittance\* Bridge is a null-type instrument for vhf and uhf measurement of the forward and reverse transfer functions and the input and output impedances and admittances of four-terminal electrical networks, either active or passive. The impedance or admittance of two-terminal circuits or components can also be measured easily.

A few examples of the measurements that can be made with this bridge are:

**Transistors—**

$$\alpha, \beta, h_i \quad h_r \quad h_i \quad h_o$$

**Tunnel Diodes—**

Equivalent circuit parameters

**Vacuum Tubes—**

$$\mu \quad Y_{21} \text{ and } Y_{12} \quad Y_{11} \text{ and } Y_{22}$$

**General two-terminal or four-terminal networks—**

$$Z_{11}, Z_{22}, Z_{21}, Z_{12}$$

$$Y_{11}, Y_{22}, Y_{21}, Y_{12}$$

$$I_2/I_1, I_1/I_2 \text{ and } E_2/E_1, E_1/E_2$$

**Ungrounded components—**

- inductors — inductance and self-resonance
- capacitors — capacitance and resonances
- resistors — resistance and shunt capacitance

\* Immittance = impedance and/or admittance

**Components, Coaxial Lines, and Other Grounded Elements—**

$$Z$$

$$Y$$

$$|\rho|, VSWR$$

**DESCRIPTION:** The Type 1607-A Transfer-Function and Immittance Bridge comprises three identical loops magnetically coupled to three coaxial lines. One of these lines is terminated with a resistance standard, one with a reactance standard, and one with the network to be tested. The coupling of each loop is adjusted until a null is obtained on an external detector. Each loop has a calibrated scale and the settings at null condition indicate the value of the unknown.

Two interchangeable loop-and-scale assemblies (Transfer-Function Indicator and Immittance Indicator, respectively) allow either



(left) Type 1607-P101 Transistor Mount  
(center) Type 1607-P201 Tube Mount  
(right) Type 1607-P401 Tetrode Transistor Mount





four-terminal or two-terminal networks to be measured with equal ease.

Two constant-impedance, adjustable-length lines are built into the instrument to eliminate the need for lead corrections.

### FEATURES:

- Simple to operate.
- Measures effective network parameters of transistors, diodes, tubes, and two-terminal and four-terminal networks, active and passive.
- Wide frequency range — 25 to 1500 Mc.
- Direct-reading.
- Suitable both for laboratory measurements and for routine production measurements.
- Component mounts available for commonly used transistors and tubes.
- Built-in provisions for dc biasing.

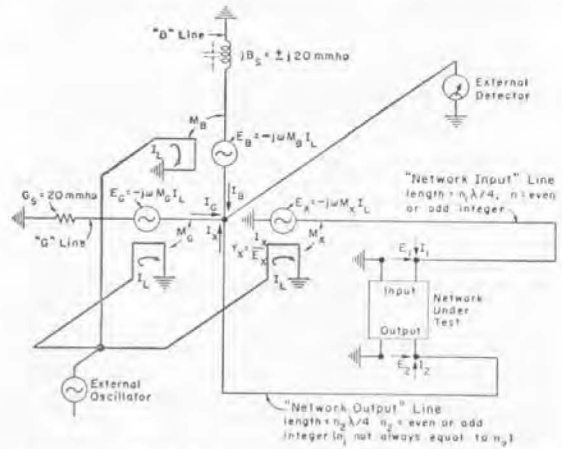

Schematic diagram of rf circuits of the Transfer-Function and Impittance Bridge.

### SPECIFICATIONS

**Frequency Range:** 25 to 1500 Mc, with reduced accuracy above 1000 Mc and when flexible cable is used in the lines. The use of this cable is required at frequencies below 150 Mc and is optional at other frequencies.

**Measurement Range:** Voltage and Current

**Ratios**  
 $(R)$  0-30  $2.5 (1 + \sqrt{R})\% + 0.025\%$

**Transimpedance ( $Z_{21}$ )** 0-1500 ohms  $2.5 \left( 1 + \sqrt{\frac{Z_{21}}{50}} \right)\% + 1.25 \text{ ohms}^*$

**Transadmittance ( $Y_{21}$ )** 0-600 mmhos  $2.5 \left( 1 + \sqrt{\frac{Y_{21}}{20}} \right)\% + 0.5 \text{ mmho}^*$

**Impedance ( $Z_{11}$ )** 0-1000 ohms  $2.0 \left( 1 + \sqrt{\frac{Z_{11}}{50}} \right)\% + 1.0 \text{ ohm}^*$

**Admittance ( $Y_{11}$ )** 0-400 mmhos  $2.0 \left( 1 + \sqrt{\frac{Y_{11}}{20}} \right)\% + 0.1 \text{ mmho}^*$

**Dc Bias:** Terminals are provided for introducing dc bias  
 \*When the 0.1 Multiple Plate is used, these residual errors are significantly reduced.

from external sources. Maximum bias current, 250 ma, continuous; higher currents are permissible for short periods; maximum bias voltage, 400 volts.

**Accessories Supplied:** Range-Extension Unit; Transfer-Function Indicator; Impittance Indicator; 6 terminations (open, short, matched, etc.); standards; 10-db attenuator; 8 air lines (21.5 and 43 cm); 3 U-line sections; constant-impedance adjustable line; a special tee; two 0.1 multiplier plates; 10 patch cords; carrying case with storage space for instrument and accessories.

**Accessories Required:** Generator, detector, and mount for unknown device. Unit Oscillators (page 110) and TYPE DNT Detectors (page 58) are recommended. For coaxial adaptors see page 42. See below for mounts available.

**Other Accessories Available:** Four transistor mounts, ungrounded component mount, and tube mounts listed in the price table below.

**Dimensions:** Case,  $11\frac{1}{4}$  by  $14\frac{1}{2}$  by 40 inches (290 by 370 by 1020 mm).

**Net Weight:** 63 pounds (29 kg).

For a more complete description of this instrument, refer to the *General Radio Experimenter*, Volume 32, No. 10, March, 1958, and Volume 33, No. 5, May, 1959.

TYPE		CODE WORD	PRICE
1607-A	Transfer-Function and Impittance Bridge . . .	HYDRA	\$1775.00
1607-P101	Transistor Mount (JEDEC-30, 0.200 in. D pin circle, for TO-5, -9, -11, -39 and similar packages)	TRANS MOUNT	60.00
1607-P102	Transistor Mount (JEDEC-30, 0.200 in. D pin circle, grounded emitter, for TO-5, 9-, -11, -39 and similar packages) . . . . .	TORIC MOUNT	60.00
1607-P111	Transistor Mount (0.100 in. D pin circle, grounded base, for TO-1, -18, -23, -24 and similar packages) . . . . .	BASEY MOUNT	65.00
1607-P201	Tube Mount (7-pin miniature, grounded cathode, for Type 6AN4 and similarly based tubes) . . . . .	TUBES MOUNT	75.00
1607-P401	Tetrode Transistor Mount (0.200 in. D pin circle, grounded base, for TO-12 and similar packages)	TETRA MOUNT	65.00
1607-P601	Ungrounded Component Mount . . . . .	COMPOMOUNT	25.00

# COAXIAL INSTRUMENTS AND COMPONENTS



At very-high and ultra-high frequencies, the inductance, capacitance, and radiation of ordinary leads make them unsuitable for most applications. Also, at high frequencies the distribution of inductance and capacitance along leads becomes significant. In order to eliminate radiation and stray-field effects and to arrange the distribution of inductance and capacitance in a manner that can be easily handled mathematically, coaxial lines having a constant value of characteristic impedance (that is, a uniform distribution of inductance and capacitance) are generally used as connecting elements. One value of characteristic impedance — 50 ohms — has been widely adopted. Other values such as 60, 72, 95, 100, and 125 are also used in special applications, but most general-purpose coaxial lines have a 50-ohm characteristic impedance.

Coaxial lines are useful at low frequencies also, because of the excellent shielding provided and because lead inductance and capacitance can be accurately calculated and controlled.

At high frequencies, the basic method of measuring the impedance of a circuit is to measure the voltage standing-wave pattern set up on a section of transmission line terminated in the unknown impedance. Unless the unknown impedance is the same as the characteristic impedance of the line, some of the power traveling from the source to the unknown is reflected back from the unknown, and, as it travels back to the source, sets up an interference pattern on the line. The actual impedance of the unknown can be determined from the ratio of the maximum to minimum amplitude of the interference pattern (standing wave) and from the electrical distance from the unknown to a minimum in the standing-wave pattern. One instrument used to measure the standing-wave pattern is the Slotted Line, which contains a small movable probe that samples the electric field at various points along the line.

Bridge circuits built in coaxial-line forms are also used to measure impedance at very high and ultra-high frequencies. Instruments of this type are the Admittance Meter and the Transfer-Function and Immittance Bridge.

For maximum utilization of instruments and for the construction of development and measurement circuits, many different types of coaxial elements are required. The General Radio line of coaxial connectors, adaptors, terminations, filters, attenuators, voltmeters, fixed and adjustable air lines, tees, elbows, and other accessories includes most types of commonly used coaxial circuit components.

acteristics as well as for the convenience offered by its unique mechanical features.

The TYPE 874 Connector has a 50-ohm characteristic impedance and is useful from dc to about 7 Gc. Any two of these connectors, although identical, can be plugged together, eliminating the inconvenience and deterioration in performance so often encountered with plug-and-jack type connectors. This hermaphrodite feature, plus the fact that TYPE 874 Connectors merely plug together without any twisting, makes the "874" the easiest-to-use coaxial connector available. All General Radio high-frequency instruments and coaxial components are equipped with TYPE 874 Connectors. To simplify use of the TYPE 874 Connector with other connectors and to permit use of other connectors with TYPE 874 equipped instruments, an extensive line of low-reflection adaptors is offered.

Recently added members of the TYPE 874 family are locking-type connectors and adaptors and recessed panel connectors. Locking and nonlocking connectors are fully compatible.† Moreover, two locking connectors can be plugged directly together without locking, in the same manner as regular connectors. If a locking connection is desired, the locking nut on one connector is screwed onto the threaded coupling nut of the other connector. Use of locking connectors, besides providing rigid mechanical connection, results in 30 to 40 db less leakage than with regular connectors.



Cutaway view of basic connector joined with cable connector.

The basic elements of the TYPE 874 Coaxial Connector are an inner conductor, an outer conductor, and a supporting polystyrene bead. The inner and outer conductors are similar in principle; each is essentially a tube with four longitudinal slots in the end and with two opposite quadrants displaced inward. When two connectors are plugged together, the undisplaced quadrants of one connector overlap the displaced quadrants

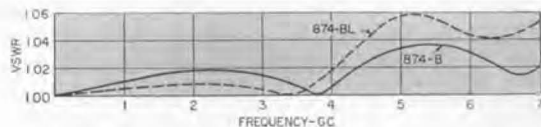

Typical VSWR of Type 874-B and -BL Connectors.

## THE TYPE 874 COAXIAL CONNECTOR \*

A coaxial connector is effectively part of a transmission line, and at very-high and ultra-high frequencies must not significantly affect the standing-wave pattern on the line. The General Radio TYPE 874 Coaxial Connector is recommended for its excellent electrical char-

acteristics and form circular inner and outer surfaces. The mutual overlapping, as well as the resulting circularity of the joined connectors, can be seen in the accompanying cross-section drawing of two connectors joined together.

\* PATENT NOTICE. See Note 4, page viii.  
† Except for 874-P Series of Panel Connectors.



(Left) Type 874 Coaxial Connector. (Right) Cross section of two connectors plugged together.



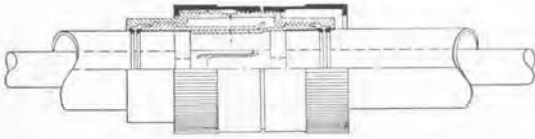

Cross-section drawing of two locking connectors joined together.

In the locking version, the basic connector is equipped with a locking nut, threaded on the inside and knurled on the outside, and a threaded coupling nut. When two locking connectors are joined, the locking nut of one is screwed onto the coupling nut of the other, while the locking nut of the second connector is backed off and not used. As with regular TYPE 874 Connectors, the locking type are hermaphrodite, any two making a pair. On locking panel connectors, the threaded locking nut is omitted, since the mating connector will always be equipped with one.

In the locking connection, the locking nut draws the two connectors together until the two coupling nuts come in contact with each other. In this position, the internal mating elements of the connector are engaged but are not bottomed against each other. Bottoming of the mating elements is avoided to prevent damage to the connector and to preserve a low VSWR.

Many of the more recently manufactured TYPE 874 Components are designed for easy substitution of a TYPE 874-BL Locking Connector for the TYPE 874-B Connector. One can easily determine whether such replacement is possible by observing whether a groove  $\frac{1}{32}$  inch wide and  $\frac{1}{64}$  inch deep is visible behind the coupling nut. If this groove is visible, a locking connector can be mounted on the component.



Type 874-QCP and -QNJA Adaptors plugged together. This assembly will connect a Type C jack to a Type N plug.

## ADAPTORS

TYPE 874 Coaxial Adaptors are useful not only for connecting TYPE 874 connectors to other connector types, but also as means of interconnecting several different systems with a minimum number of adaptors. For instance, interconnection of all combinations of TYPES N, C, BNC, and UHF plugs and jacks in a laboratory would require 32 direct adaptors (most of which are not commercially available), while only 8 TYPE 874 Adaptors will perform the same job and at the same time permit use of any of the four systems named with TYPE 874 connectors. More than 30 different TYPE 874 Adaptors permit use of TYPE 874 connectors with all commonly used military and commercial coaxial connectors.

By using the new TYPE 874 Locking Adaptors, one can semipermanently equip instruments fitted with TYPE 874-PL Locking Panel Connectors with connectors of almost any desired type. The TYPE 874 Locking Adaptor offers a connection that is not easily lost, yet one that can be quickly removed if another type of connector is desired.

When a TYPE 874-PRL Recessed Panel Connector is used, the adaptor extends only about an inch beyond the panel surface.

## INDEX

	Page		Page
Adaptors . . . . .	42, 51	Trombone . . . . .	46
Adjustable Lines . . . . .	46	Low-Pass Filters . . . . .	45
Air Lines . . . . .	46	Micrometer Vernier . . . . .	52
Attenuators . . . . .	48	Mixer Rectifier . . . . .	45
Balun . . . . .	51	Mount . . . . .	43
Cable . . . . .	44	Open-Circuit Termination . . . . .	47
Cable Connectors . . . . .	40, 41	Panel Connectors . . . . .	40, 41
Capacitor, Coupling . . . . .	43	Patch Cords . . . . .	44
Capacitor, Variable . . . . .	49	Probe, Coupling . . . . .	43
Clamps . . . . .	43, 51	Radiating Line . . . . .	43
Cliplock . . . . .	43	Rectifier, Voltmeter . . . . .	50
Component Mount . . . . .	43	Rotary Joint . . . . .	43
Connectors . . . . .	40, 41	Series Inductor . . . . .	49
Constant-Impedance Line . . . . .	46	Short-Circuit Terminations . . . . .	47
Coupling Elements . . . . .	43	Slotted Line . . . . .	52, 54
Coupling Probe . . . . .	43	Smith Charts . . . . .	55
Crimping Tools . . . . .	41	Stand . . . . .	51
Detector, Voltmeter . . . . .	50	Standard Terminations . . . . .	47
EI . . . . .	43	Stubs . . . . .	49
Filters, Low-Pass . . . . .	45	Tee . . . . .	43
Fixed Attenuators . . . . .	48	Terminal Pad . . . . .	51
Flexible Line . . . . .	44	Terminal Unit . . . . .	47
Indicator, Voltmeter . . . . .	50	Terminations . . . . .	47
Inductor, Series . . . . .	49	Tools . . . . .	41
Insertion Unit . . . . .	43	Trombone Line . . . . .	46
Kit, Slotted-Line . . . . .	54	Tuning Elements . . . . .	49
Lines . . . . .		Variable Capacitor . . . . .	49
Adjustable . . . . .	46	Vernier, Micrometer . . . . .	52
Constant-Impedance . . . . .	46	Voltmeters, Coaxial . . . . .	50
Radiating . . . . .	43	Voltmeter, Rectifier . . . . .	50
Rigid . . . . .	46	Wrenches . . . . .	41





## CONNECTORS

The TYPE 874 Coaxial Connector line includes some 30 different connectors for use on cables, panels, and rigid air line. The familiar TYPE 874, any two of which, although identical, plug together, is now available in a locking version for use where rigid connection is desired. Other additions to the TYPE 874 family are recessed panel connectors, which add to the appearance of an instrument while subtracting from the bench space required. All connectors of the TYPE 874 line are compatible with one another; any two (regular, locking, or one of each) still make a pair.\*

Although TYPE 874 Connectors can be assembled with ordinary pliers and wrenches, a tool kit is available and is recommended for added convenience.

Maximum input voltage for TYPE 874 Connectors is 1.5 kilovolts. Maximum input power is 150 watts at 1000 Mc, and is inversely proportional to the square root of frequency.

### TYPE 874-B BASIC CONNECTORS

For use on rigid, 50-ohm, air-dielectric, coaxial lines. Consists of inner and outer conductors, insulating bead, coupling nut, and retaining ring. Fits lines made from  $\frac{5}{8}$ -inch-OD,  $\frac{9}{16}$ -inch-ID tubing and 0.244-inch-diameter rod. The inner conductor is to be screwed into an 8-32 hole tapped in the end of the rod, and the retaining ring for the coupling nut is to be snapped into a  $\frac{1}{64}$ -inch-deep, 0.035-inch-wide groove cut in the tubing.

The TYPE 874-BL Locking Connector includes a threaded locking nut for use with other TYPE 874 locking connectors and adaptors. Locking connectors are fully compatible with regular, non-locking connectors.\*

**Net Weight:** 1 ounce (30 g).



Type 874-QUJL Locking Adaptor secured to Type 874-PRL Recessed Panel Connector converts latter to rigid, semipermanent UHF jack.

### TYPE 874-C CABLE CONNECTORS

For use on TYPE RG cables as well as on General Radio TYPE 874-A2 Cable. Consists of a basic connector plus inner and outer transition pieces, soft copper ferrule, and rubber guard. The transition pieces are tapered

Unassembled Type 874-B Basic Connector.



to maintain the characteristic impedance of the connector and cable throughout the change in diameter. The cable inner conductor is to be soldered to the inner transition piece, and the cable braid is held against the outer transition piece by the crimped ferrule. The rubber guard provides strain relief and a protective handle.  
**Net Weight:** 2 ounces (60 g).

The TYPE 874-CL Locking Cable Connector includes a threaded locking nut for use with other TYPE 874 locking connectors and adaptors. Locking connectors are fully compatible with regular, non-locking connectors.\*

**Net Weight:** 2½ ounces (70 g).

### PANEL CONNECTORS

**TYPE 874-P.** Similar to the TYPE 874-C Cable Connector except with a panel adaptor and nut in place of the rubber guard. The panel adaptor fits into a  $\frac{15}{16}$ -inch-diameter hole in a panel  $\frac{1}{16}$  to  $\frac{1}{4}$  inch thick, and will clamp the connector in any desired orientation.

**Net Weight:** 3 ounces (85 g).

**TYPE 874-PB.** Flange-mounted panel connector. Requires a  $\frac{15}{16}$ -inch-diameter hole in panel of any thickness. Four No. 29 (0.136-inch) holes are drilled in flange,  $\frac{13}{16}$  inch center to center, to accept machine screws. Panel space required is  $1\frac{1}{16}$  by  $1\frac{1}{16}$  inch.

**Net Weight:** 2 ounces (60 g).

**TYPE 874-PL.** Locking-type panel connector. Requires a  $\frac{15}{16}$ -inch-diameter hole in panel  $\frac{1}{16}$  to  $\frac{1}{4}$  inch thick. Connector is screw-mounted, and requires four No. 29 (0.136-inch) holes,  $\frac{13}{16}$  inch center to center, to accept machine screws. Threaded coupling nut accepts any of the TYPE 874 locking connectors or adaptors. Connector also accepts nonlocking connectors.\* Panel space required is  $1\frac{1}{16}$  by  $1\frac{1}{16}$  inch.

**Net Weight:** 2 ounces (60 g).

**TYPE 874-PRL.** Locking-type panel connector, designed for recessed mounting to save space and present neat panel appearance. Requires  $1\frac{1}{32}$ -inch-diameter hole in panel from  $\frac{1}{16}$  to  $\frac{1}{4}$  inch thick. Connector is screw-mounted, and requires four No. 29 (0.136-inch) holes,  $\frac{13}{16}$  inch center to center, to accept machine screws. Connector accepts both locking and regular TYPE 874 Connectors.\* Installed TYPE 874-PRL Connector protrudes only about  $\frac{1}{8}$  inch beyond panel front, and requires only  $1\frac{3}{16}$  by  $1\frac{3}{16}$  inch of panel space.

**Net Weight:** 2½ ounces (70 g).

\* Except for 874-P Series of Panel Connectors which will not mate with locking connectors.

## TYPE 874 COAXIAL CONNECTORS

	TYPE	FITS	CODE WORD	PRICE	
Basic Connectors	874-B	50-ohm Rigid Air Line	COAXBRIDGE	\$1.60	Shown on page 40
	874-BL	50-ohm Rigid Air Line (locking connector)	COAXYPIIT	2.50	
Cable Connectors	874-C	874-A2 Cable	COAXCABLER	2.30	
	874-C8	RG-8/U Cable	COAXCORDER	2.30	
	874-C9	RG-9/U, RG-116/U Cables	COAXCAMMER	2.30	
	874-C58	874-A3, RG-29/U, RG-55/U, RG-58/U, RG-58A/U Cables	COAXCALLER	2.30	
	874-C62	RG-59/U, RG-62/U Cables (nonconstant impedance)	COAXCANDOR	2.30	
Cable Connectors —Locking	874-CL	874-A2 Cable	COAXYROBIN	3.50	
	874-CL8	RG-8/U Cable	COAXPARROT	3.50	
	874-CL9	RG-9/U, RG-116/U Cables	COAXYJUNCO	3.50	
	874-CL58	874-A3, RG-29/U, RG-55/U, RG-58/U, RG-58A/U Cables	COAXYSNIPE	3.50	
	874-CL62	RG-59/U, RG-62/U Cables (nonconstant impedance)	COAXYSWIFT	3.50	
Panel Connectors	874-P	874-A2 Cable	COAXPEGGER	3.20	
	874-P8	RG-8/U, RG-9/U, RG-116/U Cables	COAXPUTTER	3.20	
	874-P58	874-A3, RG-29/U, RG-55/U, RG-58/U, RG-58A/U Cables	COAXPANNER	3.20	
	874-P62	RG-59/U, RG-62/U Cables (nonconstant impedance)	COAXPOLLER	3.20	
Panel Connectors —Flanged	874-PB	874-A2 Cable	COAXAPPLER	3.20	
	874-PB8	RG-8/U, RG-9/U, RG-116/U Cables	COAXBATHER	3.20	
	874-PB58	874-A3, RG-29/U, RG-55/U, RG-58/U, RG-58A/U Cables	COAXABATER	3.20	
	874-PB62	RG-59/U, RG-62/U Cables (nonconstant impedance)	COAXBARKER	3.20	
Panel Connectors —Locking	874-PL	874-A2 Cable	COAXYFINCH	3.75	
	874-PL8	RG-8/U, RG-9/U, RG-116/U Cables	COAXYVIREO	3.75	
	874-PL58	874-A3, RG-29/U, RG-55/U, RG-58/U, RG-58A/U Cables	COAXTHRUSH	3.75	
	874-PL62	RG-59/U, RG-62/U Cables (nonconstant impedance)	COAXTOUCAN	3.75	
	874-PLT	Wire Lead	COAXWILLET	3.75	
Panel Connectors —Locking, Recessed	874-PRL	874-A2 Cable	COAXYGOOSE	4.00	
	874-PRL8	RG-8/U, RG-9/U, RG-116/U Cables	COAXCONDOR	4.00	
	874-PRL58	874-A3, RG-29/U, RG-55/U, RG-58/U, RG-58A/U Cables	COAXCURLEW	4.00	
	874-PRL62	RG-59/U, RG-62/U Cable (nonconstant impedance)	COAXAVOCET	4.00	
	874-PRLT	Wire Lead	COAXMERLIN	4.00	

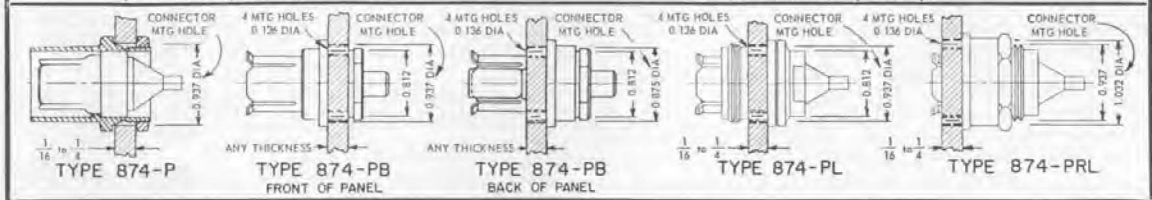

## TOOLS

The TYPE 874-TOK Tool Kit consists of an inner-conductor wrench to hold and install both the insulating bead and the inner connectors, and an outer-conductor wrench and a coupling-nut wrench to install the outer connector and to tighten the coupling nut. While all TYPE 874 connectors can be assembled with ordinary tools, use of these wrenches will greatly facilitate installation of connectors on both rigid line and cable.

When a TYPE 874 Connector is installed on shielded cable, a ferrule must be crimped to secure the cable braid to the shell of the connector. Pliers can be used to crimp the ferrule, but where many connectors are to be installed, or where the neatest possible crimp is desired, use of the TYPE 874-TO58 or -TO8 Crimping Tool is recommended to produce a hexagonally shaped crimp.

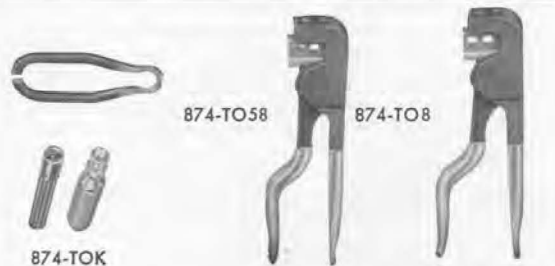

CONNECTOR	CRIMPING TOOL TYPE
874-C, CL, C58, CL58, C62, CL62, P, PB, PL, PRL, P58, PB58, PL58, PRL58, P62, PB62, PL62, PRL62	874-TO58
874-C8, CL8, C9, CL9, P8, PB8, PL8, PRL8	874-TO8

TYPE	Tool Kit	CODE WORD	PRICE
874-TOK	Tool Kit	COAXKITEN	\$20.00
874-TO58	Crimping Tool	COAXCRIMPO	85.00
874-TO8	Crimping Tool	COAXCRIMBA	75.00



## ADAPTORS

TYPE 874-Q Adaptors permit interconnection of TYPE 874 Connectors and most other military and commercial coaxial connectors, and are also widely used to cross-connect other types of connectors. (See illustration on page 39.) Because of the fact that any two TYPE 874 Adaptors mate with each other, a few TYPE 874 Adaptors can perform an interconnection job that would otherwise require a large number of direct adaptors — assuming the latter were available.

In ordering adaptors by type number, remember that the letter suffix indicates the type of connector on the adaptor, and not the type connector that the adaptor fits. (For instance, the J in TYPE 874-QNJ indicates

that the adaptor contains a TYPE N jack, and therefore fits a TYPE N plug.) A final L in the type designation indicates a locking adaptor, that is, one that contains a locking TYPE 874 Connector. These locking adaptors can be used to convert TYPE 874-PRL recessed panel connectors into neat, semipermanent TYPE BNC, C, N, SC, TNC, or UHF jacks.

TYPE 874-QU1A, -QU2, and -QU3A Adaptors are used to connect the rigid lines in television transmitting antenna systems to instruments fitted with TYPE 874 Connectors, as, for instance, the TYPE 1602-B UHF Admittance Meter and the TYPE 874-LBA Slotted Line.

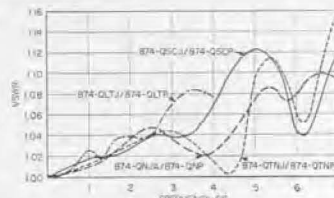
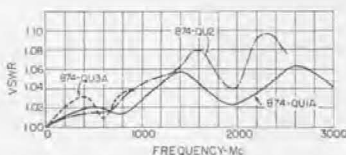
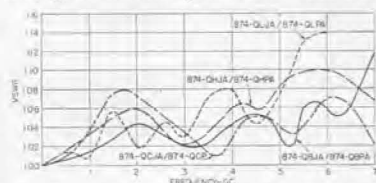

Typical VSWR introduced in line by pairs of Type 874 Adaptors plugged together.

### ADAPTORS

	TYPE	CONNECTS TYPE 874 TO . . .	NET WT*	CODE WORD	PRICE
TO TYPE <b>BNC</b>	874-QBJA	BNC Plug	1 oz	COAXBIGGER	\$4.75
	874-QBJL	BNC Plug (locking 874)	1 1/2 oz	COAXCASHEW	5.75
	874-QBJA	BNC Jack	1 1/2 oz	COAXBUNNER	5.25
TO TYPE <b>C</b>	874-QCJA	C Plug	1 oz	COAXCOGGER	5.50
	874-QCJL	C Plug (locking 874)	2 oz	COAXYPECAN	6.50
	874-QCP	C Jack	2 oz	COAXCUFFER	6.25
TO TYPE <b>HN</b>	874-QHJA	HN Plug	1 1/2 oz	COAXHAWSER	6.00
	874-QHPA	HN Jack	2 1/2 oz	COAXHANGER	7.50
TO TYPE <b>LC</b>	874-QLJA	LC Plug	5 oz	COAXLITTER	12.00
	874-QLPA	LC Jack	7 1/2 oz	COAXLUGGER	20.00
TO TYPE <b>LT</b>	874-QLTJ	LT Plug	4 3/4 oz	COAXLAGGER	20.00
	874-QLTP	LT Jack	7 oz	COAXLOBBER	25.00
TO TYPE <b>N</b>	874-QNJA	N Plug	1 1/2 oz	COAXNAGGER	5.00
	874-QNJL	N Plug (locking 874)	2 oz	COAXWALNUT	6.00
	874-QNP	N Jack	1 3/4 oz	COAXNUTTER	5.00
TO TYPE <b>SC</b>	874-QSCJ	SC Plug (Sandia)	1 3/8 oz	COAXCOSTER	9.00
	874-QSCJL	SC Plug (Sandia) (locking 874)	2 oz	COAXALMOND	10.00
	874-QSCP	SC Jack (Sandia)	1 5/8 oz	COAXCASHER	9.00
TO TYPE <b>TNC</b>	874-QTNJ	TNC Plug (Sandia)	1 oz	COAXTUNNER	6.50
	874-QTNJL	TNC Plug (Sandia) (locking 874)	1 1/2 oz	COAXYHAZEL	7.50
	874-QTNP	TNC Jack (Sandia)	1 1/4 oz	COAXTUSKER	6.50
TO TYPE <b>UHF</b>	874-QUJ	UHF Plug	1 oz	COAXYUNDER	5.00
	874-QUJL	UHF Plug (locking 874)	2 oz	COAXYBEECH	6.00
	874-QUJ	UHF Jack	1 1/2 oz	COAXPUPPER	5.00
TO TYPE <b>274</b>	874-Q2	274 Plug or Jack	2 oz	COAXTIPPER	5.50
	874-Q9	938 Binding Posts	3 oz	COAXPOSTER	6.00
	874-QN6	274-NO Patch Cord	1 oz	COAXCHOSER	3.75
TO UHF RIGID LINE	874-QU1A	3/8-in. 50Ω UHF Rigid Line, RG-155/U (EIA TR-134)	7 oz	COAXYUMBER	35.00
	874-QU2	1 1/8-in. 50Ω UHF Rigid Line, RG-153/U (EIA TR-134)	1 1/4 lb	COAXYUSHER	80.00
	874-QU3A	3 1/2-in. 50Ω UHF Rigid Line, RG-154/U (EIA-TR134)	5 1/4 lb	COAXYULTRA	135.00



Shown on page 240



\* To convert oz to g, multiply by 28; to convert lb to kg, divide by 2.2.



### COUPLING ELEMENTS

**TYPE 874-K COUPLING CAPACITOR.** A short length of coaxial line having a cylindrical capacitor in series with the inner conductor. High frequencies are transmitted with small reflections, but dc and low audio frequencies are blocked.

**Coupling Capacitance:** 4700 pf  $-20\%$   $+50\%$ .  
**VSWR:** Less than 1.06 at 1000 Mc, 1.15 at 2000 Mc, 1.3 from 2000 to 4000 Mc.  
**Voltage Rating:** 500 volts.  
**Length:** 3 inches (76 mm).

**TYPE 874-LR RADIATING LINE.** Allows coupling to the fields within a coaxial system. Short coaxial line with opening in outer conductor that can be partly or completely covered by a rotatable sleeve.

**VSWR:** Closed, less than 1.05 at 1000 Mc, less than 1.4 at 3000 Mc, and less than 1.35 at 4000 Mc.

**TYPE 874-MB COUPLING PROBE.** Electrostatic probe consisting of a binding post mounted on a TYPE 874 Coaxial Connector.

**Over-all Length:** 3 inches (76 mm).

**TYPE 874-EL 90° ELL.** Convenient right-angle line section with TYPE 874 Coaxial Connector at each end.

**Characteristic Impedance:** 50 ohms.  
**Electrical Length:** Approximately 7 cm.  
**VSWR:** Less than 1.06 at 2000 Mc; less than 1.5 at 4000 Mc.

**TYPE 874-JR ROTARY JOINT.** Used when one part of a system must be rotated with respect to another part. Not for motor-driven applications.

**VSWR:** Less than 1.06 at 1000 Mc; less than 1.3 at 4000 Mc.

**TYPE 874-T TEE.** For connecting stubs and other elements in shunt with a coaxial line.

**TYPE 874-X INSERTION UNIT.** This is a hollow cylinder fitted with a TYPE 874 Connector at each end, and with a sleeve that slides back to provide access to a space about 2 inches long

and  $\frac{9}{16}$  inch in diameter. In this space may be mounted arrangements of small components, such as resistors, capacitors, or inductors. The insertion unit can be used as a shielded housing for impedance-matching networks, attenuator pads, vhf transformers, filters, and many other networks. It offers excellent shielding, minimum discontinuity in the line, and convenience.

**TYPE 874-Y CLIPLOCK.** A spring that can be slipped over TYPE 874 Coaxial Connectors to provide secure lock, preventing accidental disconnection or slippage.

**TYPE 874-M COMPONENT MOUNT.** A shielded enclosure with jack-top binding posts inside, TYPE 874 Coaxial Connector outside, for convenience mounting of small components being measured. Use of mount minimizes "lead" reactance and stray capacitance in impedance measurements of circuit elements and networks from dc to 5000 Mc. Connects directly to TYPE 874-LBA Slotted Line, TYPE 1602-B Admittance Meter, TYPE 874-LK Adjustable Lines, and all GR coaxial elements.

Supplied with the mount are short- and open-circuit terminations to simplify determination of corrections for length of line between measuring point and component being measured.

**Frequency Range:** Dc to 5000 Mc.  
**Accessories Supplied:** One TYPE 874-WN3 Short-Circuit Termination, one TYPE 874-WO3 Open-Circuit Termination.

**Accessory Recommended:** One TYPE 874-LK20 Constant-Impedance Adjustable Line (page 46) for use with TYPE 1602-B Admittance Meter.

**Dimension:** Diameter 3 inches (76 mm); height of shield can,  $2\frac{5}{8}$  inches (65 mm).

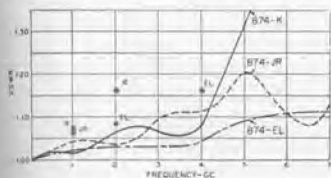

Typical VSWR of Types 874-K, -EL, and -JR. (Specifications are shown in red.)

TYPE		CODE WORD	NET WT*	PRICE
874-K	Coupling Capacitor	COAXKICKER	3 oz	\$9.50
874-LR	Radiating Line	COAXMITTER	4 oz	12.00
874-MB	Coupling Probe	COAXPROBER	3 oz	3.50
874-EL	90° Ell	COAXANGLER	3 oz	8.50
874-JR	Rotary Joint	COAXJOINER	3 oz	12.00
874-T	Tee	COAXTOGGER	3 oz	11.00
874-X	Insertion Unit	COAXHOPPER	4 oz	12.00
874-Y	Cliplock	COAXLOCKER	1oz/10	10 for 2.50
874-M	Component Mount	COAXYMOUNT	8 oz	27.50

\* To convert oz to g, multiply by 28.





874-A2 or -A3



874-R20



874-R33



874-R22



874-R22L



874-R34

## COAXIAL CABLE AND PATCH CORDS

### CABLES

**TYPE 874-A2 COAXIAL CABLE.** Flexible double-shielded bulk cable for permanent or semipermanent installations. Consists of No. 14 standard inner conductor separated from the two braided tinned-copper shields by 0.250-inch OD polyethylene insulation, and a 0.365-inch OD outer polyvinyl-chloride jacket.

**Characteristic Impedance:** 50 ohms  $\pm 5\%$ .

**Nominal Capacitance:** 29 pf per foot.

**Attenuation:** 2.6 db per 100 ft at 100 Mc; 10.5 db per 100 ft at 1000 Mc.

**Propagation Velocity Factor:** 66%.

**Net Weight:** 2  $\frac{1}{4}$  lb (1.3 kg) per 25 ft.

**TYPE 874-A3 COAXIAL CABLE.** Same as above except inner conductor is 19 strands of 0.0066-inch tinned soft copper wire, separated from the two braided shields by 0.116-inch OD polyethylene insulation, and a 0.206-inch OD outer polyvinyl-chloride jacket. More flexible than the TYPE 874-A2, but losses are higher. Recommended for most general-purpose applications.

**Characteristic Impedance:** 50 ohms  $\pm 5\%$ .

**Nominal Capacitance:** 29 pf per foot.

**Attenuation:** 5.3 db per 100 ft at 100 Mc; 22 db per ft at 1000 Mc; 45 db per 100 ft at 3000 Mc.

**Propagation Velocity Factor:** 66%.

**Net Weight:** 1 lb (0.45 kg) per 25 ft.

### PATCH CORDS

**TYPE 874-R20 PATCH CORD.** For connections where maximum shielding and minimum loss are desired. Consists of three feet of TYPE 874-A2 Cable with a TYPE 874-C Cable Connector on each end.

**Net Weight:** 7 ounces (200 g).

**TYPE 874-R22 PATCH CORD.** Consists of three feet of TYPE 874-A3 Cable with a TYPE 874-C58 Cable Connector on each end. Recommended where both maximum shielding and flexibility are needed.

**Net Weight:** 4 ounces (115 g).

**TYPE 874-R22L PATCH CORD.** Same as TYPE 874-R22 except with TYPE 874-CL58 Locking Cable Connector on each end.

**Net Weight:** 6 ounces (170 g).

**TYPE 874-R33 PATCH CORD.** Consists of three feet of flexible, single-shielded, 50-ohm coaxial cable, with one end terminated in a TYPE 874-C58 Coaxial Connector and the other in single TYPE 274 Plugs.

**Net Weight:** 4 ounces (115 g).

**TYPE 874-R34 PATCH CORD.** Similar to TYPE 874-R33, but with one end terminated in a TYPE 274-NK Shielded Double Plug rather than single TYPE 274 Plugs.

**Net Weight:** 4 ounces (115 g).

TYPE		CODE WORD	PRICE
874-A2	Coaxial Cable	COAXCUTTER	\$0.50/ft (0.27/ft in lengths of 25 ft or more)
874-A3	Coaxial Cable	COAXGABBER	0.35/ft (0.20/ft in lengths of 25 ft or more)
874-R20	Patch Cord	COAXHATTER	7.50
874-R22	Patch Cord	COAXFANNER	7.60
874-R22L	Patch Cord	COAXYFIXER	10.00
874-R33	Patch Cord	COAXLINKER	5.00
874-R34	Patch Cord	COAXFITTER	6.00



## FILTERS



### TYPE 874-F LOW-PASS FILTERS

Reduction of harmonics from a uhf generator is usually necessary for best measurement results, especially with systems containing

Typical Insertion Loss and VSWR, Type 874-F Filters.

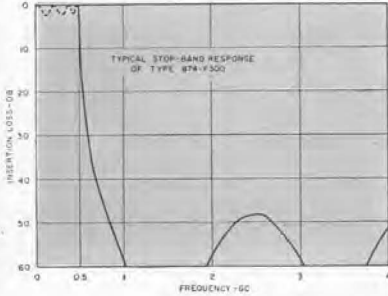
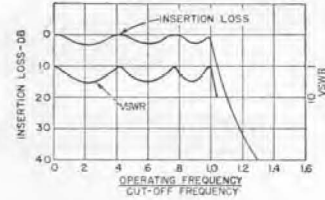

Typical Stop-band Response of Type 874-F500 Low-Pass Filter.

voltmeters, nonlinear elements, or sections that might resonate at a harmonic frequency, or if high standing-wave ratios are to be measured by means of a slotted line. The TYPE 874-F Low-Pass Filters are of the Tschebyscheff type, which produces a very steep cutoff characteristic at the expense of passband flatness. Owing to dissimilarities in the individual sections in each filter, spurious responses in the stop band are very small.

Accuracy of Cutoff Frequencies:  $-0\%$ ,  $+10\%$ .

TYPE		PHYSICAL LENGTH†	NET WEIGHT*	CODE WORD	PRICE
874-F185	185-Mc Low-Pass Filter	17 $\frac{5}{8}$ in.	14 oz	COAXRUFFER	\$30.00
874-F500	500-Mc Low-Pass Filter	10 $\frac{3}{4}$ in.	8 oz	COAXDIPPER	24.00
874-F1000	1000-Mc Low-Pass Filter	7 $\frac{1}{8}$ in.	6 oz	COAXMEGGER	22.00
874-F2000	2000-Mc Low-Pass Filter	4 $\frac{3}{8}$ in.	5 oz	COAXPUSHER	22.00
874-F4000	4000-Mc Low-Pass Filter	2 $\frac{7}{8}$ in.	4 oz	COAXLENDER	22.00

\* To convert oz to g, multiply by 28. † To convert in. to mm, multiply by 25.4.

## MIXER



TYPE 874-MR  
MIXER RECTIFIER

Schematic diagram of Type 874-MR.

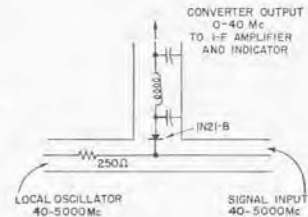

The Mixer Rectifier is a useful frequency converter, and in combination with a TYPE 1216-A Unit I-F Amplifier\* it forms a universal uhf-vhf heterodyne detector for the laboratory. The high-frequency signal is mixed with a signal from a local oscillator (fundamental or harmonic) to produce a difference frequency of 30 Mc, which is then fed to the

i-f amplifier. The 250-ohm series resistor isolates the signal circuit from the local-oscillator circuit.

\* Other i-f amplifiers or receivers operating at frequencies between 0 and 40 Mc can also be used.

## SPECIFICATIONS

Operating Frequency Range: 40 to 5000 Mc; at lower and higher frequencies with decreased sensitivity.

Maximum Crystal Current: 25 ma.

Maximum Input from Local Oscillator: 2 volts.

Cutoff Frequency of Output Filter: 40 Mc.

Output Impedance: Approx. 400 ohms.

Accessories Required: Local oscillator for heterodyning

(Unit Oscillators are recommended). Patch cords (page 44) are needed for connections. For complete detector assembly, see page 58.

Net Weight: 5 ounces (140 g).

TYPE		CODE WORD	PRICE
874-MR	Mixer Rectifier	COAXVERTER	\$32.50



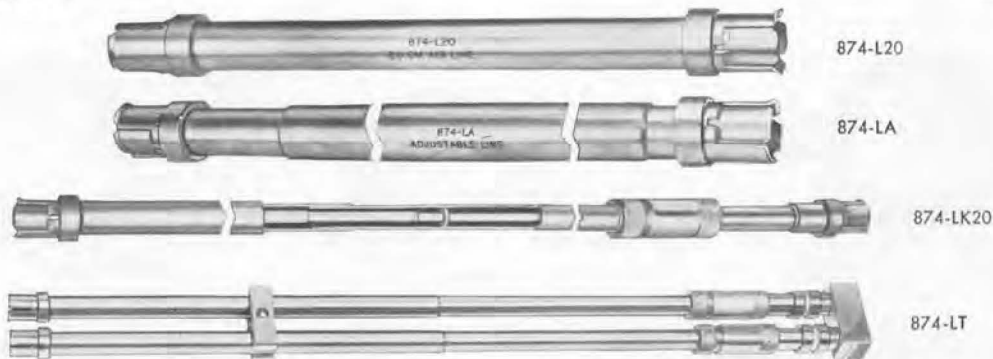

### FIXED AND ADJUSTABLE AIR LINES

#### TYPE 874-L10, -L20, -L30, RIGID AIR LINES.

For spacing stubs or other elements of a coaxial system. Each air line consists of a length (10, 20, or 30 cm) of 50-ohm, air-dielectric coaxial line with a Type 874 Coaxial Connector at each end.

**TYPE 874-LA ADJUSTABLE LINE.** An air-dielectric coaxial line that can be telescoped to change its length. Used in matching networks. Contacts are made by multiple spring fingers.

**Characteristic Impedance:** Not constant — approximately 50 ohms when fully collapsed, approximately 57 ohms when fully extended.

**Adjustment Range:** 25 cm.

**Physical Length:** 33 cm (min) to 58 cm (max).

**TYPE 874-LK10, -LK20 CONSTANT-IMPEDANCE ADJUSTABLE LINES.** A line stretcher with a very low VSWR and a uniform characteristic impedance of 50 ohms. Especially useful for eliminating the usual Smith-chart corrections for length of line between unknown and impedance-measuring device. The Type 1602-B Admittance Meter can be made direct-reading in impedance by adjustment of the over-all line length to an odd multiple of a quarter wavelength. This line is also useful as an impedance-matching transformer and phase-adjustment element in coaxial systems.

**Impedance:** 50 ohms.

**Adjustment Range:** Type 874-LK10, 10 cm (half wave length at 1500 Mc); Type 874-LK20, 22 cm (half wave length at 680 Mc).

**Physical Length:** Type 874-LK10, 35 cm (min) to 45 cm (max); Type 874-LK20, 58 cm (min) to 80 cm (max).

**VSWR:** Type 874-LK20 — less than 1.03 at 500 Mc, less than 1.06 at 1000 Mc, less than 1.08 at 1500 Mc, less than 1.10 at 2000 Mc.

Type 874-LK10 — same as Type 874-LK20 to 2000 Mc, less than 1.15 at 3000 Mc, less than 1.2 at 4000 Mc, less than 1.25 at 5000 Mc.

**TYPE 874-LT TROMBONE CONSTANT-IMPEDANCE ADJUSTABLE LINE.** With this line stretcher, built like a trombone slide, the user can vary the length of a 50-ohm transmission line between two fixed terminals without moving either terminal or using flexible cable. Consists of two Type 874-LK20 Adjustable Lines mounted parallel to one another and joined at one end by a U-shaped section to form a rigid assembly. Can be plugged into two adjacent Type 874 Coaxial Connectors or inserted in a line by means of two clls (not included) when line is used vertically to save space. Low VSWR. An excellent phasing unit.

**Characteristic Impedance:** 50 ohms.

**Frequency Range:** Dc to 2000 Mc (Type 874-LK10 is recommended above 2000 Mc).

**Adjustment Range:** 44 cm (half wave at 340 Mc).

**Physical Length:** 61 cm (min) to 83 cm (max).

**Spacing:**  $1\frac{3}{16}$  inches between centers.

**VSWR:** Less than 1.10 to 1000 Mc, and 1.25 to 2000 Mc.

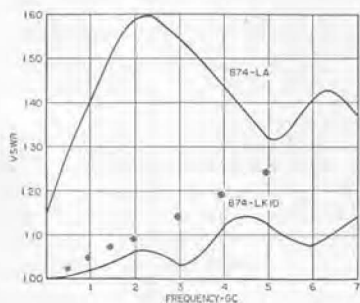

Typical VSWR of Types 874-LA and -LK10. (Specifications are shown in red.)

TYPE		NET WT*	CODE WORD	PRICE
874-L10	10-cm Air Line	2 oz	COAXDECKER	\$8.00
874-L20	20-cm Air Line	4 oz	COAXVENTER	8.50
874-L30	30-cm Air Line	6 oz	COAXTRIPLY	9.00
874-LA	Adjustable Line	10 oz	COAXLAPPER	25.00
874-LK10	10-cm Constant-Impedance Adjustable Line	10 oz	COAXKENTER	40.00
874-LK20	22-cm Constant-Impedance Adjustable Line	14 oz	COAXKEEPER	40.00
874-LT	Constant-Impedance Trombone Line	2 lb	COAXTROMBO	95.00

\* To convert oz to g, multiply by 28.







## STANDARD TERMINATIONS

**TYPE 874-WM 50-OHM TERMINATION.** A 50-ohm cylindrical resistor mounted in a tapered coaxial holder, useful for impedance matching, establishment of reference conditions, and termination of filters and attenuators.

**Dc Resistance:** 50 ohms  $\pm 1\%$ .

**Maximum Power:**  $\frac{1}{2}$  watt continuous, 500 watts peak.  
**VSWR:** Less than 1.05 to 1000 Mc, 1.08 to 2000 Mc, 1.13 to 4000 Mc.

**TYPE 874-WN SHORT-CIRCUIT TERMINATION.** A fixed shorting strap mounted in a connector, for establishing reference conditions on coaxial lines and for use in substitution measurements.

**TYPE 874-WN3 SHORT-CIRCUIT TERMINATION.** Same as TYPE 874-WN except that the short circuit is at a point 3 cm (3.2 cm electrical distance) beyond the face of the bead in the TYPE 874 Connector. This distance corresponds to the distance between the bead and the ground plane of the TYPE 874-M Component Mount (see page 43) and the effective distance between the bead and the balanced terminals in the TYPE 874-UB Balun (see page 51).

**TYPE 874-WO OPEN-CIRCUIT TERMINATION.** A shielding cap for open-circuited lines, for establishing reference conditions on coaxial lines and for use in substitution measurements. Produces an open circuit at same point in line that TYPE 874-WN produces a short circuit.

**TYPE 874-WO3 OPEN-CIRCUIT TERMINATION.** Same as TYPE 874-WO, except that position of open circuit corresponds to position of short circuit in TYPE 874-WN3.

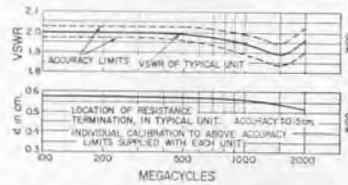

Typical VSWR and position of pure resistance termination for (above) Type 874-W100 and (below) Type 874-W200.  $d$  is the distance from the position of the short or open circuit produced by a Type 874-WN3 or -WO3 to the position of the pure resistance termination.

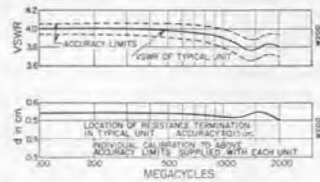

**TYPE 874-W100 100-OHM COAXIAL STANDARD.** Produces known resistive termination at specific locations on coaxial lines. Useful for checking detector linearity, accuracy of directional couplers, bridges, and admittance meters. The known location of the purely resistive termination permits the production of many known complex impedances through the addition of sections of TYPE 874-L Air Line (page 46).

**Dc Resistance:** 100 ohms  $\pm 1\%$ .

**Maximum Power:**  $\frac{1}{8}$  watt continuous, 150 watts peak.

**TYPE 874-W200 200-OHM COAXIAL STANDARD.** Same as TYPE 874-W100 except standard resistance is 200 ohms.

**Dc Resistance:** 200 ohms  $\pm 1\%$ .

**Maximum Power:**  $\frac{1}{4}$  watt continuous, 50 watts peak.

TYPE		NET WEIGHT*	CODE WORD	PRICE
874-WM	50-ohm Termination	2½ oz	COAXMETER	\$17.50
874-WN	Short-Circuit Termination	2 oz	COAXNULLER	3.50
874-WN3	Short-Circuit Termination	2 oz	COAXYTRINU	4.75
874-WO	Open-Circuit Termination	2 oz	COAXOPENER	2.00
874-WO3	Open-Circuit Termination	2 oz	COAXYTRIPO	3.75
874-W100	100-ohm Coaxial Standard	3 oz	COAXCENTER	35.00
874-W200	200-ohm Coaxial Standard	3 oz	COAXILTER	35.00

\*To convert oz to g, multiply by 28.





874-G10



874-GA

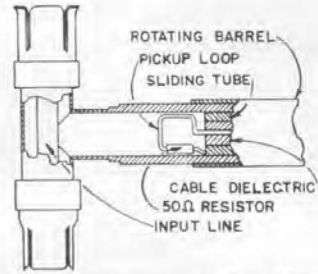

Cross section of coupling system used in Type 874-GA.

## ATTENUATORS

### TYPE 874-GA ADJUSTABLE ATTENUATOR

A mutual-inductance (waveguide-below-cut-off) type of attenuator, useful for producing known voltage ratios, for measuring attenuation, and for adjusting voltage magnitude. Consists of a loop that can be positioned longitudinally within a hollow tube by the rotation of an outside sleeve. One turn of the sleeve produces a 20-db change in attenuation. Sleeve and tube are calibrated directly in decibels of relative attenuation on a micrometer-type scale. The absolute attenuation is the sum of the insertion loss and the attenuator reading. The input system is a short coaxial line with a connector at each end, one end for connection to the power source and the other for connection to a 50-ohm termination, an adjustable stub, or any desired load. The output of the loop is brought out through three feet of double-shielded 50-ohm flexible cable, which is approximately matched at the

**Calibrated Range:** 120 db (relative attenuation) with input line terminated in 50-ohms; 129 db with input line terminated in adjustable stub to minimize the electric field at the coupling point (scale reads -9 to 120 db). Usable range depends upon shielding between input and output.

**Insertion Loss:** (from input connector to end of output cable at 1000 Mc, when signal source impedance is 50 ohms)

With input line terminated in 50 ohms, and scale set at 0 db:  $33 \pm 2$  db; set at -9 db:  $18 \pm 2$  db (scale settings below 0 are not accurate).

With input line terminated in adjustable stub (which extends the range over which the calibration is accurate to the -9-db scale setting):  $20 \pm 2$  db minimum.

(Insertion loss is approximately inversely proportional to frequency up to 1000 Mc.)

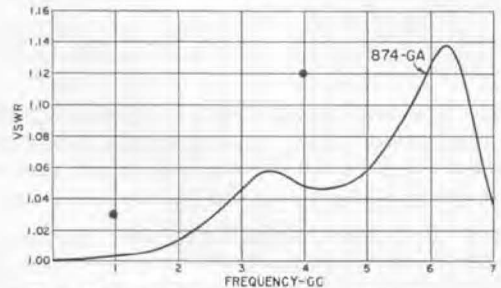

Typical VSWR of Type 874-GA Adjustable Attenuator. (Specifications are shown in red.)

loop end by a 50-ohm resistor between the low side of the loop and ground.

Can be used with TYPE 874-VR Voltmeter Rectifier and TYPE 874-VI Voltmeter Indicator to convert a Unit Oscillator into a signal generator.

**Insertion Loss Directly Through Tee:** Negligible.

**Accuracy of Attenuation**

**Stub-terminated input:**  $\pm(1\%$  of difference in attenuation reading  $+0.2)$  db, direct reading ( $-9$  to 60 db).

**50-ohm terminated input:**  $\pm(1\frac{1}{2}\%$  of difference in attenuation readings  $\pm 0.2)$  db, when corrected (0 to 60 db). Correction chart supplied.

**Cutoff Frequency:** 12,300 Mc.

**VSWR Introduced into Line:** Less than 1.03 at 1000 Mc; less than 1.12 between 1000 and 4000 Mc.

**VSWR of Output:** Less than 4 at 1000 Mc, less than 5 up to 4000 Mc.

**Maximum Permissible Power:** Maximum power in input line is inversely proportional to square root of frequency, and should not exceed 150 watts at 1000 Mc. Output power should not exceed  $\frac{1}{2}$  watt.

**Frequency Range:** 100 to 4000 Mc.

**Net Weight:**  $1\frac{1}{4}$  pounds (0.6 kg).

### TYPE 874-G3, -G6, -G10, -G20 FIXED ATTENUATORS

Single-section, T-type resistance pads, useful for adding fixed known attenuation in 50-ohm systems and for matching generators or loads

to 50 ohms. Consists of one disk resistor and two cylindrical resistors, as shunt and series elements respectively.



**Dc Resistance:** 50 ohms  $\pm 1\%$  when terminated in 50 ohms.

**VSWR:** Less than 1.1 to 1000 Mc, 1.2 to 3000 Mc for all units; to 4000 Mc, less than 1.3 for -G20, 1.35 for -G10, and 1.4 for -G3 and -G6.

**Accuracy of Attenuation in 50-ohm System:**  $\pm 1.5\%$  of nominal attenuation at dc;  $\pm 0.2$  db from value indicated on curve to 1000 Mc,  $\pm 0.4$  db to 2000 Mc,  $\pm 0.6$  db to 4000 Mc.

**Temperature Coefficient:** Less than .0003 db/ $^{\circ}$ C/db.

**Maximum Power Input:** 1 watt continuous, 3000 watts peak.

**Physical Length:**  $3\frac{1}{2}$  inches (90 mm) over-all.

**Net Weight:** 2 ounces (60 g).

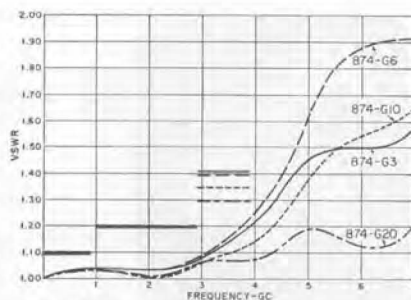

Typical VSWR of Type 874-G Attenuators.  
(Specifications are shown in red.)

TYPE		CODE WORD	PRICE
874-GA	Adjustable Attenuator.....	COAXLOSSER	\$65.00
874-G3	Fixed Attenuator (3 db).....	COAXFULLER	36.00
874-G6	Fixed Attenuator (6 db).....	COAXNODDER	30.00
874-G10	Fixed Attenuator (10 db).....	COAXBELLER	30.00
874-G20	Fixed Attenuator (20 db).....	COAXNEPPER	30.00



874-VC



874-D20



874-XL

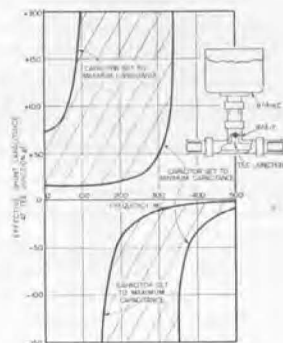

## TUNING ELEMENTS

### TYPE 874-D20 AND -D50 ADJUSTABLE STUBS.

For matching or tuning and for use as reactive elements. Can be used with indicator and scale as reaction-type wavemeters. Consists of a coaxial line with a sliding short circuit of the multiple-spring-finger type. The 20-cm stub is calibrated in electrical length from the junction of the branch line with the through line in a TYPE 874-T. The 50-cm stub is not calibrated but has an adjustable reference marker.

**Characteristic Impedance:** 50 ohms.

**Maximum Travel of Short Circuit:** TYPE 874-D20, 20 cm; TYPE 874-D50, 50 cm.

**Physical Length:** TYPE 874-D20, 28 cm (min) to 48 cm (max); TYPE 874-D50, 58 cm (min) to 109 cm (max).

### TYPE 874-VC VARIABLE CAPACITOR. Tuning

TYPE		NET WEIGHT*	CODE WORD	PRICE
874-D20	20-cm Adjustable Stub.....	6 oz	COAXTUBBER	\$15.00
874-D50	50-cm Adjustable Stub.....	10 oz	COAXBIGGER	18.00
874-VC	Variable Capacitor.....	12 oz	COAXYFARAD	60.00
874-XL	Series Inductor.....	3 oz	COAXDUCTOR	15.00

\* To convert oz to g, multiply by 28.

element for resonant-line circuits, matching transformers, and baluns at low frequencies where line-type elements are awkward to use. Well-shielded, high-temperature polystyrene insulation and precision ball bearings.

**Scale:** 0-100.

**Capacitance Range:** High frequencies, see curve. Low frequencies, 14 to 70 pf at connector, 16.5 to 72.5 pf at T-junction.

**Capacitance Variation:** Linear.

**Dimensions:** Diameter  $2\frac{1}{2}$  inches (62 mm), height  $5\frac{1}{4}$  inches (135 mm).

**TYPE 874-XL SERIES INDUCTOR.** Used as a general-purpose tuning element in resonant-line circuits, matching transformers, and baluns at low frequencies.

**Series Inductance:**  $0.226 \mu\text{h} \pm 5\%$  at 1 kc.



# COAXIAL VOLTMETERS



874-VI

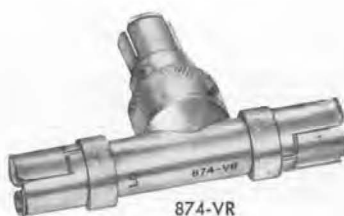

874-VR

## COAXIAL VOLTMETERS

### TYPE 874-VQ VOLTMETER DETECTOR

Can be used with Voltmeter Indicator (see below) for voltage measurement, with a tuned audio amplifier such as the TYPE 1232-A Tuned Amplifier as a sensitive detector (approx 100  $\mu\text{V}$ ) of modulated signals, or with a microammeter as an rf detector. It introduces no appreciable discontinuity when inserted in a 50-ohm coaxial line. With the TYPE 874-WM 50-ohm termination, it can be used as a matched detector to terminate a line.

**Frequency Range as Matched Detector:** 0.5 to 2000 Mc. Usable from 60 cps to 5000 Mc.

**Resonant Frequency:** Approximately 5400 Mc; correction curve supplied.

**Maximum Rf Voltage:** 2 volts.

**VSWR:** Less than 1.1 at 1000 Mc, 1.2 at 2000 Mc.

**Crystal:** 1N23B.

**Bypass Capacitance:** Approximately 300 pf.

**Dimensions:** Length  $3\frac{3}{4}$ , height  $2\frac{1}{2}$  inches (95 by 65 mm).

**Net Weight:** 5 ounces (140 g).

modulated signals and a tuned audio amplifier such as the TYPE 1232-A Tuned Amplifier.

**Frequency Range for Voltage Measurements:** 15 to 2500 Mc, subject to resonance correction above 500 Mc. Voltage indications and correct voltage ratios can be obtained at both higher and lower frequencies. See curve.

**Resonant Frequency:** Approximately 5400 Mc; correction curve supplied.

**Maximum Voltage:** 2 volts.

**Crystal:** 1N23B.

**Bypass Capacitance:** Approximately 300 pf.

**Dimensions:** Length  $3\frac{3}{4}$ , height  $2\frac{1}{2}$  inches (95 by 65 mm).

**Net Weight:** 5 ounces (140 g).

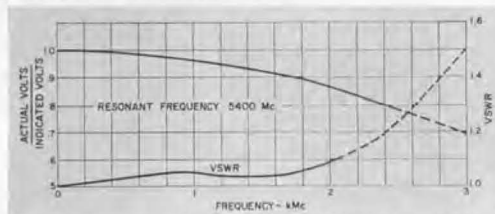

Average correction factor for Types 874-VQ and 874-VR.

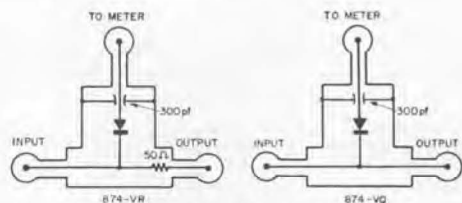

Schematic diagram of Types 874-VR and 874-VQ.

### TYPE 874-VR VOLTMETER RECTIFIER

In conjunction with the Voltmeter Indicator (see below), can be used to measure or to monitor the voltage in coaxial systems. It contains a 50-ohm resistor in series with the output line, and thus can be used to measure the voltage behind a 50-ohm impedance. The unit, when used with a signal source, will simulate a 50-ohm generator with a known, equivalent open-circuit voltage. In addition it is a good general-purpose detector, and can be used with a microammeter or, when high sensitivity is desired (approx. 100  $\mu\text{V}$ ), with

### TYPE 874-VI VOLTMETER INDICATOR

Indicates the rectified dc output of either the TYPE 874-VQ or TYPE 874-VR and provides means for measuring the voltage at any level between 0.1 and 2 volts. A built-in 60-cps calibration system eliminates errors arising from differences in crystal rectification efficiencies.

**Range and Accuracy of Calibrating Voltage:** 0.1 to 2 volts  $\pm .05$  volt.

**Crystal Current for Full-Scale Indication:** 200  $\mu\text{A}$ .

**Power Supply:** 105 to 125 (or 210 to 250) volts, 50 to 60 cps.

**Input Resistance:** 600 ohms minimum, 10,000 ohms maximum.

**Accessories Supplied:** TYPE CAP-22 Power Cord.

**Other Accessories Required:** One TYPE 871-R34 Patch Cord (page 44) required to connect Voltmeter Rectifier to Voltmeter Indicator.

**Dimensions:**  $5\frac{1}{2}$  by  $5\frac{1}{2}$  by  $4\frac{1}{2}$  inches (140 by 140 by 105 mm) over-all.

**Net Weight:** 3 lb 1 oz (1.5 kg).

TYPE		CODE WORD	PRICE
874-VQ	Voltmeter Detector	COAXVOQUER	\$30.00
874-VR	Voltmeter Rectifier	COAXRECTOR	30.00
874-VI	Voltmeter Indicator	COAXVOLTER	90.00





## BALUN AND ACCESSORIES

### TYPE 874-UB BALUN

The TYPE 874-UB Balun is a tuned coaxial transformer that permits measurements on balanced devices with generally available coaxial and grounded measuring equipment. Used with the TYPE 874-LBA Slotted Line or the TYPE 1602-B Admittance Meter, it permits balanced measurements on 200-ohm balanced components from 54 to 1000 Mc without appreciable insertion loss or transformation error. When the Balun is used with the Admittance Meter and the TYPE 874-LK Constant-Impedance Adjustable Line, the Admittance Meter reads balanced impedance directly.

The balun converts from unbalanced to balanced accurately by using an artificial half-wave line, adjusted for operation at a particular frequency by means of shunt tuning elements. These elements, listed below and described on page 49, are not supplied with the Balun but should be ordered separately.

Frequency Range — Mc	Tuning Elements Required
54-88	2 Type 874-VC and 2 Type 874-XL
88-140	2 Type 874-VC and 2 Type 874-L30
140-174	2 Type 874-VC and 2 Type 874-L20
174-216	2 Type 874-VC and 2 Type 874-L10
170-280	2 Type 874-D50 and 2 Type 874-L30
225-280	2 Type 874-D20 and 2 Type 874-L30
275-380	2 Type 874-D20 and 2 Type 874-L20
350-525	2 Type 874-D20 and 2 Type 874-L10
470-1000	2 Type 874-D20

**Frequency Range:** 54 to 1000 Mc with accessory elements as listed above.

**Accessories Supplied:** One TYPE 874-UB-P1 300-ohm Terminal, one TYPE 874-WN3 Short-Circuit Termination, one TYPE 874-WO3 Open-Circuit Termination.

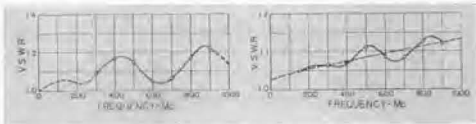

Typical VSWR of Type 874-UB-P3 (left) and Type 874-BM (right)

TYPE	DESCRIPTION	CODE WORD	NET WEIGHT*	PRICE
874-UB	Balun	COAXYBALUN	1 ¼ lb	\$75.00
874-BM	300-ohm Balanced Termination	COAXLOADER	1 ½ oz	12.00
874-UB-P2	200-ohm Terminal Unit	COAXTERMER	1 oz	6.50
874-UB-P3	300-ohm Terminal Pad	COAXTUGGER	2 oz	18.00
874-UB-P4	Adaptor (Balun to Twinax)	COAXWINNY	4 ½ oz	60.00
874-Z	Stand	COAXHELPER	5 ½ lb	19.50
874-ZC	Extra Clamp	COAXYCLAMP	3 oz	2.25

\* To convert oz to g, multiply by 28; to convert lb to kg, divide by 2.2.

**Other Accessories Recommended:** One TYPE 874-LK20 Adjustable Line (for use with the TYPE 1602-B Admittance Meter), one TYPE 874-Z Stand, and tuning elements listed above.

**TYPE 874-BM 300-OHM BALANCED TERMINATION.** Facilitates balanced-line measurements.

**Dc Resistance:** 300 ohms  $\pm 5\%$ .

**Frequency Range:** 0 to 1000 Mc.

**VSWR:** 1.2 to 900 Mc.

**TYPE 874-UB-P2 200-OHM TERMINAL UNIT.** Connects the balun to a balanced network whose impedance is to be measured at its own terminals. The balun converts the 200-ohm balanced line to a 50-ohm coaxial line; thus, the 200-ohm balanced line can be treated as an extension of the 50-ohm line of the measuring device.

**Characteristic Impedance:** 200 ohms.

**Frequency Range:** Dc to 1000 Mc.

**Recommended Transmission Line:** RG-86/U.

**VSWR:** 1.2 to 300 Mc, 1.3 to 1000 Mc.

**TYPE 874-UB-P3 300-OHM TERMINAL PAD.** Converts to 300 ohms the 200-ohm balanced output impedance produced from a 50-ohm unbalanced source by the balun. This pad facilitates power and voltage measurements on balanced systems with signal generators and detectors designed for use with 50-ohm coaxial circuits.

**TYPE 874-UB-P4 ADAPTOR.** Provides a reliable shielded connection between the balun and TYPE RG-22 U (small-size twinax) cable. Adaptor includes TYPE UG-422/U twinax connector, which connects to TYPE UG-421/U cable connector.

### TYPE 874-Z STAND

A firm support for components of coaxial systems. Consists of a heavy cast-iron base with rubber feet, 22-inch and 8-inch stainless-steel rods, and three universal clamps. The vertical rod can be used to hold long tuning stubs. The horizontal rod can be moved longitudinally or can be interchanged with the vertical rod to provide support where needed. Two bases can be used with one 22-inch rod between them to support a long horizontal run of coaxial parts. Clamps will fit a range of diameters and will hold between two rods of different diameters. Any desired arrangement can be set up quickly. Base can be bolted to table top for permanent setups.



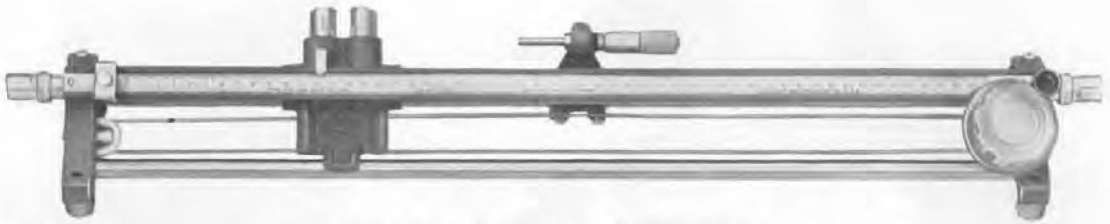

Type 874-LBA Slotted Line with Type 874-LV Micrometer Vernier

## SLOTTED LINE

### TYPE 874-LBA SLOTTED LINE

**USES:** One of the most important basic measuring instruments used at uhf is the slotted line. With it, the standing-wave pattern of the electric field in a coaxial transmission line can be measured and the VSWR, phase of the reflected wave, impedance of the load, wavelength of the rf signal, losses in attached elements, degree of mismatch between load and line, and other characteristics of antennas, components, coaxial elements, and networks can be determined.

The frequency range of the Slotted Line is from 300 to 5000 Mc. The addition of lengths of TYPE 874 Air Line (page 46) extends the frequency range to below 300 Mc.

Measurements can be made on balanced lines and components with the aid of a TYPE 874-UB Balun (page 51).

**DESCRIPTION:** The Slotted Line is a 50-ohm air-dielectric, coaxial line whose electric field is sampled by a probe that projects through a longitudinal slot in the line. Probe coupling is adjustable. The probe carriage is driven by a pulley-and-cord arrangement conveniently operated from one end of the line, and can be precisely set. A source of about 1 milliwatt rf power is adequate for most measurements. Suitable generators are listed on the next page. A crystal rectifier is built into the carriage and can be tuned to the operating frequency by means of an adjustable stub. The crystal output can be used to deflect a microammeter or, if the driving oscillator is modulated, to operate an audio amplifier. Another excellent detector is a heterodyne type with a crystal mixer and i-f amplifier. All three types of detector are described on the next page.

### FEATURES:

- Highly accurate but reasonably priced.
- Rugged enough for production use.

- Wide frequency range, from below 300 Mc to 5000 Mc.
- Self-cleaning and self-lubricating.
- Wide variety of accessories available (see following page).
- Low-reflection adaptors available to connect to most types of coaxial connectors.

### SPECIFICATIONS

**Characteristic Impedance:** 50 ohms  $\pm 1\frac{1}{2}\%$ .

**Probe Travel:** 50 cm. Scale is calibrated in millimeters.

**Scale Accuracy:**  $\pm(0.1 \text{ mm} + 0.05\%)$ .

**Frequency Range:** 300 to 5000 Mc. At 300 Mc, the Slotted Line covers a half wavelength. Operation below 300 Mc is possible with slightly reduced accuracy by use of lengths of TYPE 874 Air Lines (page 46).

**Constancy of Probe Penetration:**  $\pm 1\frac{1}{2}\%$ .

**Residual VSWR:** Less than 1.025 at 1000 Mc, less than 1.07 at 4000 Mc.

**Accessories Supplied:** Storage box and spare drive cable.

**Accessories Required:** Adjustable Stub (TYPE 874-D20) for tuning the crystal rectifier when audio-frequency detector or microammeter is used; suitable detector and generator (page 53); one each TYPE 874-R22 and TYPE 874-R34 Patch Cords for generator and detector connections.

**Accessories Available:** A complete kit of TYPE 874 coaxial elements is described on page 54. For measurement of VSWR greater than 10, a TYPE 874-LV Micrometer Vernier is recommended. Smith Charts are listed on page 55. Adaptors are listed on page 42.

**Dimensions:** 26 by 4 $\frac{1}{2}$  by 3 $\frac{1}{2}$  inches (660 by 115 by 89 mm).

**Net Weight:** 8 $\frac{1}{2}$  pounds (3.9 kg).

### TYPE 874-LV MICROMETER VERNIER

For precise measurements of high VSWR by the width-of-minimum method. Consists of a micrometer head calibrated in centimeters (calibrated to .001 cm), mounted on an arm that can be attached to the rear base rod of the slotted line. One turn of the micrometer barrel advances the head by 0.5 mm. Maximum range is 2 cm. Can be read to  $\pm .002$  mm.

TYPE	CODE WORD	PRICE
874-LBA	Slotted Line	COAXRUNNER \$230.00
874-LV	Micrometer Vernier	COAXREADER 30.00



## SLOTTED LINE ACCESSORIES

### GENERATORS

Unit Oscillators are available to cover any portion of the frequency range of the Slotted Line. Standard-Signal Generators, such as the TYPE 1021-AU and 1021-AV (page 90) may also be used. Except for the TYPE 1214, Unit Oscillators do not include power supplies; the TYPE 1203-B Unit Power Supply is recommended for general use. Where line voltage is subject to frequent variations, the TYPE 1201-B Unit Regulated Power Supply should be used.

If a modulated signal is desired, the TYPE 1214-A (sine wave) or TYPE 1210-C Unit Oscillator (sine or square wave) can be used to supply the modulating signal.

With the TYPE 1264-A Modulating Power Supply, the signal can be modulated by 1-ke square waves. This power supply was designed as a companion to the TYPE 1361-A Unit Oscillator, but can be used satisfactorily with the other Unit Oscillators listed.

	TYPE		PAGE	PRICE
Generators	1215-B	Unit Oscillator, 50-250 Mc	110	\$210.00
	1208-B	Unit Oscillator, 65-500 Mc	110	230.00
	1209-B	Unit Oscillator, 250-920 Mc	110	260.00
	1361-A	Unit Oscillator, 450-1050 Mc	109	285.00
	1218-A	Unit Oscillator, 900-2000 Mc	110	465.00
	1220-A	Unit Oscillator, 2700-7425 Mc	113	*
Power Supplies	1203-B	Unit Power Supply	137	50.00
	1201-B	Unit Regulated Power Supply	137	85.00
	1264-A	Modulating Power Supply	139	285.00
Modulators	1214-A	Unit Oscillator	106	75.00
	1210-C	Unit R-C Oscillator	102	180.00

\* Price depends on frequency.

### DETECTORS

Any one of three types of detector can be used with the Slotted Line: a heterodyne detector,

a microammeter and built-in crystal, or a VSWR amplifier and indicator.

An excellent general-purpose uhf detector is the heterodyne type. The General Radio TYPE DNT Detectors cover the frequency range from 40 to 2030 Mc (up to 5000 Mc by the use of harmonics). Each TYPE DNT system includes a local oscillator, i-f amplifier, mixer, filter, attenuator pad, and ell.

The simplest suitable detector is a microammeter and built-in crystal. Sensitivity is low, but it can be used satisfactorily with high-power oscillators. Excellent results can be obtained with a 50- $\mu$ a meter and oscillator power between 100 mw and 20 watts for VSWR's between 1 and 5. A TYPE 874-D20 20-cm Tuning Stub is required. Meter sensitivity control consisting of a 10-kilohm variable shunt resistor is recommended.

Most popular VSWR meters will serve as satisfactory detectors with the TYPE 874-LBA. Use of such a detector requires that the generator be modulated at 1 kc. Also, a TYPE 874-D20 20-cm Stub is required for tuning.

TYPE		PAGE	PRICE
DNT-1	Detector (40 to 530 Mc)	58	\$665.00
DNT-3	Detector (220 to 950 Mc)	58	693.00
DNT-4	Detector (870 to 2030 Mc†)	58	898.00
874-D20	20-cm Stub	49	15.00

† Up to 5000 Mc by the use of harmonics.

### FILTERS

A low-pass filter should be used between generator and slotted line to eliminate harmonics of the signal source. The filter cutoff frequency should be chosen to pass the fundamental but not harmonics. See page 45 for complete specifications.

TYPE		PAGE	PRICE
874-F185	185-Mc Low-Pass Filter	45	\$30.00
874-F500	500-Mc Low-Pass Filter	45	24.00
874-F1000	1000-Mc Low-Pass Filter	45	22.00
874-F2000	2000-Mc Low-Pass Filter	45	22.00
874-F4000	4000-Mc Low-Pass Filter	45	22.00

Typical measurement setups showing Slotted Line used with (left) VSWR indicator and (right) heterodyne detector.

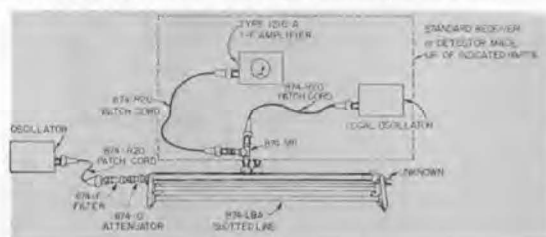
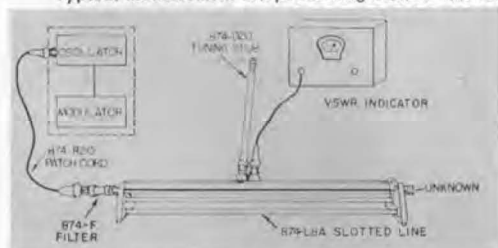



### COAXIAL KITS



#### TYPE 874-EK BASIC SLOTTED-LINE KIT

For impedance and VSWR measurements with the slotted line, a group of coaxial elements is available as the TYPE 874-EK Basic

Slotted-Line Kit. The TYPE 874-LBA Slotted Line is included in the kit, but generator and detector are not.

TYPE		QUANTITY	PRICE
874-A2	Coaxial Cable .....	25 ft	\$6.75
874-B	Basic Connector .....	2	3.20
874-C	Cable Connector .....	2	4.60
874-C8	Cable Connector .....	2	4.60
874-D20	Adjustable Stub .....	1	15.00
874-D50	Adjustable Stub .....	1	18.00
874-LA	Adjustable Line .....	1	25.00
874-LBA	Slotted Line .....	1	230.00
874-P	Panel Connector .....	2	6.40
874-QNJA	Adaptor to Type N Plug .....	1	5.00
874-QNP	Adaptor to Type N Jack .....	1	5.00
874-R20	Flexible Line .....	2	15.00
874-R34	Patch Cord .....	1	6.00
874-T	Tee .....	1	11.00
874-WM	50-ohm Termination .....	1	17.50
874-WN	Short-Circuit Termination .....	1	3.50
874-WO	Open-Circuit Termination .....	1	2.00
874-Z	Stand .....	1	19.50
874-EK	Basic Slotted-Line Kit .....		\$398.05

#### KITS FOR THE MEASUREMENTS OF CABLE CHARACTERISTICS

Various combinations of TYPE 874 Coaxial Elements can be used very effectively with Unit Instruments and associated equipment to measure attenuation, characteristic impedance, velocity of propagation, and capacitance of both coaxial and twin-conductor cables. For convenience in ordering, the necessary equipment is offered in assemblies for specific types of measurement. These kits and their use are described in Reprint E-104, "The Measurement of Cable Characteristics," available on request.





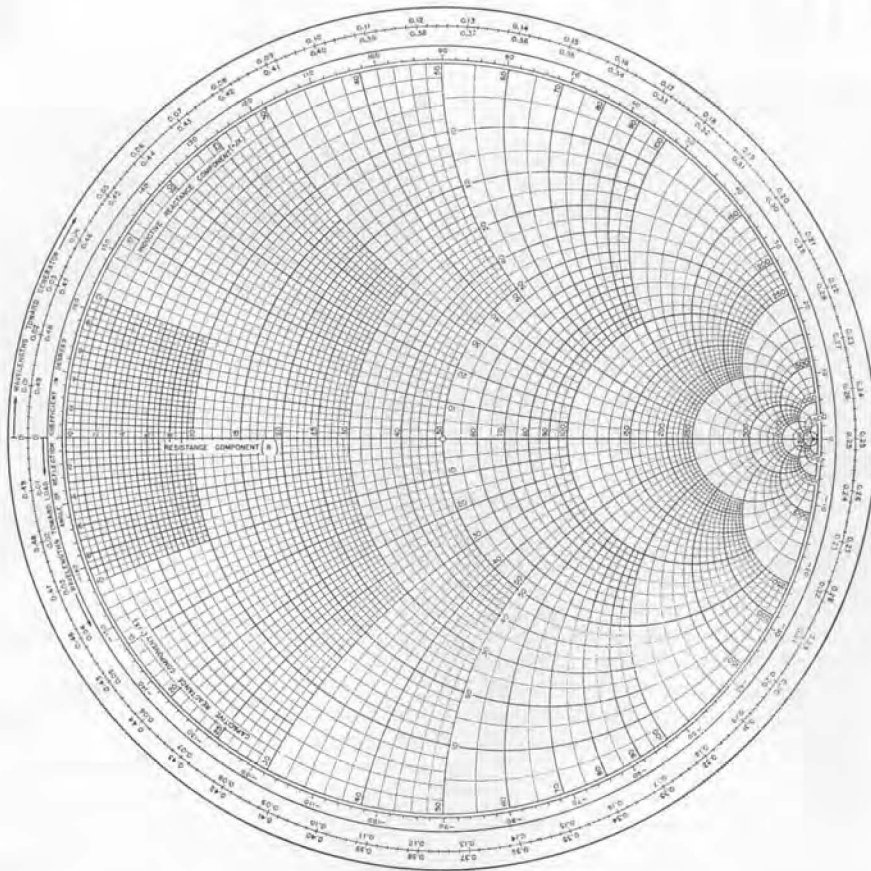

### SMITH CHARTS

In impedance and VSWR measurements, it is often necessary to determine the impedance transformation produced by a length of transmission line. Equations can be used, but the calculations are laborious. A chart on which calculations can be made graphically with very little effort was devised by P. H. Smith<sup>1</sup> and is known as the Smith Chart. The chart can be used to determine the VSWR corresponding to any impedance and to convert from impedance to admittance and vice versa. This chart is very useful for measurements using the TYPE 1602-B Admittance Meter

and the TYPE 874-LBA Slotted Line.

Four forms of Smith Chart are available: one with normalized coordinates, for use with lines of any impedance; one with normalized expanded coordinates; one with impedance coordinates based on a 50-ohm characteristic impedance; and one with admittance coordinates based on a 20-mmho characteristic admittance. The 50-ohm characteristic impedance (20-mmho characteristic admittance) is common to all General Radio coaxial equipment. Charts are printed on thin 8½ by 11 inch paper.

TYPE	CODE WORD	QUANTITY	PRICE
<b>Smith Chart-Admittance Coordinates</b> (20-mmho characteristic admittance)	ADMITCHART	50 <sup>2</sup>	\$2.00
<b>Smith Chart-Impedance Coordinates</b> (50-ohm characteristic impedance)	IMPEDCHART	100	3.75
<b>Smith Chart-Normalized Coordinates</b>	NORMACHART EXPANCHART	200	7.00
<b>Smith Chart-Normalized Expanded Coordinates</b>		500	14.00
		1000	25.00

<sup>1</sup>Electronics, Vol 17, No 1, pp 130-133, 318-325, January 1944.

<sup>2</sup>Minimum quantity sold.





# DETECTORS AND AMPLIFIERS

## DETECTORS

In practically all types of electrical measurements, a means must be provided for aural or visual indication of the desired measurement condition. For bridge measurements, the indicator, or detector, must have some degree of selectivity to eliminate spurious signals, noise, and harmonics of the desired signal. For voltage amplitude measurements, a wide linear range is desirable, and in modulation measurements the output signal should be a faithful reproduction of the modulation envelope.

For these applications, a number of detectors are in common use:

1. Amplifier followed by a meter or headphones.
2. Simple rectifier to convert an ac signal to dc or to demodulate an rf signal.
3. Simple rectifier followed by a high-gain amplifier with an aural or visual indicator.
4. Mixer in which the signal to be measured is heterodyned with a signal of a different frequency from an oscillator and the difference frequency amplified in a fixed-frequency, band-pass, high-gain amplifier.



Type DNT Detector is recommended for use with the Type 1602-B UHF Admittance Meter and is shown here with the Admittance Meter in the measurement of resistors at 800 Mc.

An amplifier with meter or headphones is commonly used in the frequency range between a few cycles and several megacycles.

The TYPE 1232-A Tuned Amplifier and Null Detector is an instrument of this type, tunable over the audio-frequency range, with two additional operating frequencies at 50 and 100 kc. Its unusually high sensitivity, low noise level, excellent selectivity, and high gain make it suitable for the most exacting bridge-measurement requirements.

The Type 1212-A Unit Null Detector is an untuned detector, which covers a wide frequency range and uses limiting amplifiers to produce a non-linear compression of the meter scale of at least 100 db, thus eliminating the need for amplifier gain adjustments during bridge balancing operations.

For maximum effective sensitivity, one of the accessory filters should be used at the input: the TYPE 1212-P1, for eliminating pickup at the power-line frequency in measurements above 10 kc; and the TYPE 1212-P2, for maximum sensitivity and selectivity at 1 megacycle.

Simple rectifiers are often used at the higher frequencies. The Type 874-VQ Voltmeter Detector and Type 874-VR Voltmeter Rectifier cover a very wide frequency range, as indicated on the chart. When used directly with a meter or a telephone headset, the sensitivity is low. Used with an audio amplifier, such as

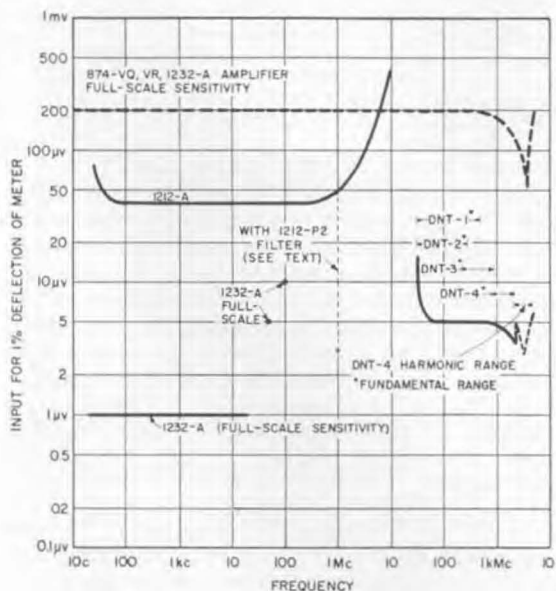

Sensitivity and frequency range of various detectors. The sensitivity figures shown for the Type 874-VQ and -VR Detectors are for a modulated signal (50% or more) with the amplifier tuned to the modulator frequency. At frequencies below about 500 kc an additional bypass capacitor must be added to obtain the sensitivity indicated.





the TYPE 1232-A, they are sensitive detectors of modulated signals.

At very-high and ultra-high frequencies, the heterodyne method of detection has many advantages. It can have high sensitivity, a wide frequency range, any amount of selectivity, and excellent linearity. In the *Type DNT Detectors*, the signal is heterodyned in a TYPE 874-MR Mixer Rectifier with a signal from a Unit Oscillator. The 30-Mc beat frequency is amplified and detected by a TYPE 1216-A Unit I-F Amplifier. Various local oscillators can be used to cover the very extensive frequency range shown in the chart, and harmonic operation can be used to extend the range of any oscillator. The 80-db linear range is also useful in relative voltage-level measurement.

TYPE	CLASS	SEE PAGE
1232-A	High-Gain Tuned Amplifier	60
1212-A	Broadband Logarithmic Amplifier	61
DNT	Heterodyne with I-F Amplifier	58
874-VQ,-VR	Crystal Rectifier	50

## AMPLIFIERS

The General Radio Company manufactures a variety of laboratory amplifiers which meet many of the needs for amplification in research, engineering, and industry. The following amplifiers are described in this section:

1. *The Type 1232-A Tuned Amplifier and Null Detector*, which, in addition to its uses as a null detector, is an excellent preamplifier for use with microphones, vibration pickups and oscilloscopes. In combination with the TYPE 874-VQ Voltmeter Detector it becomes a sensitive detector of modulated signals at frequencies up to 5000 Mc.

2. *Type 1233-A Power Amplifier* provides several watts of power over a wide frequency range. In addition to its uses at audio and ultrasonic frequencies, it can be used as a wide-band voltage amplifier at frequencies up to 3 Mc, and, with external tuning, as a tuned amplifier up to 5 Mc.

3. *The Type 1206-B Unit Amplifier* is a high-quality, general-purpose, 3-watt amplifier, which operates over the audio and ultrasonic frequency ranges, and which has excellent transient response. An outstanding feature of this instrument is its low-frequency response, which extends down to 2 cycles per second with a drop of only 3 db.

The combination of this amplifier and the



For dc amplification, the Type 1230-A DC Amplifier and Electrometer can be used. It is described on page 128.

TYPE 1210-C Unit R-C Oscillator comprises a compact oscillator of 3-watt output up to 100 kc and 0.4 watt up to 500 kc.

TYPE	NAME	SEE PAGE
1232-A	Tuned Amplifier and Null Detector	60
1233-A	Power Amplifier	63
1206-B	Unit Amplifier	64

## OTHER AMPLIFIERS

In addition to the amplifiers described in this section, special-purpose amplifiers are described in other sections of the catalog.

**DC AMPLIFIER:** The TYPE 1230-A D-C Amplifier and Electrometer is an extremely stable instrument capable of amplifying very weak dc voltages and operating a recorder from the output.

**PULSE AMPLIFIER:** The TYPE 1219-A Pulse Amplifier will produce pulse currents up to one-half ampere from low-power pulse generators.

**SOUND-LEVEL METER:** The TYPE 1551-C Sound-Level Meter is a high-gain amplifier and logarithmic voltmeter, with a full-scale sensitivity of 20 microvolts and a range of 126 db.

TYPE	NAME	SEE PAGE
1230-A	DC Amplifier and Electrometer	128
1219-A	Pulse Amplifier	119
1551-C	Sound-Level Meter	182





### TYPE 1216-A UNIT I-F AMPLIFIER



#### TYPE DNT HETERODYNE DETECTORS (40-2030 MC)

**USES:** The 30-Mc Unit I-F Amplifier is the basic element in a general-purpose, well-shielded, high-frequency, heterodyne detector, the other elements being a mixer, a local oscillator, and a filter (see diagram). Complete detector assemblies (TYPE DNT) are listed below.

This heterodyne detector is a high-sensitivity, high-frequency voltmeter for relative signal levels, a standing-wave indicator, and a null detector.

As an indicator of relative signal levels, it can be used to measure the insertion loss and attenuation of filters, attenuators, and cable; crosstalk in coaxial switches and other devices; to calibrate attenuators; as a field-strength indicator; to measure antenna gain and radiation patterns; and as a general-purpose high-frequency receiver. Since the mixer is linear over a wide range of input voltages, the built-in step attenuator makes possible direct signal-level measurements over an 80-db range. With the use of external TYPE 874-G20 Attenuators, this range can usually be extended to about 110 db. When the instrument is standardized in terms of an rf voltage standard, as, for instance, a standard-signal generator, it can be used for absolute voltage measurements. In this application, the high sensitivity (see curve) permits measurements down to a few microvolts.

This detector is recommended for use as a standing-wave indicator with the TYPE 874-LBA Slotted Line.

As a null detector, it is recommended for use with the TYPE 1602-B UHF Admittance Meter and the TYPE 1607-A Transfer-Function and Immittance Bridge.

**DESCRIPTION:** The TYPE 1216-A Unit I-F Amplifier consists of four tuned i-f amplifier stages, a detector, a video amplifier stage, an rf attenuator, and two power supplies. It is designed to operate from a 400-ohm source impedance, which is the nominal output impedance of the TYPE 874-MR Mixer Rectifier.

Automatic volume control is provided to facilitate bridge balancing and other null-type measurements. The AVC can be switched out of circuit for voltage level measurements.

A built-in, precision, film-type-resistor, step attenuator is included to make possible accurate measurements of relative signal levels as high as 80 db. The indicating meter is calibrated in db, as well as in linear units, for convenient interpolation between the 10-db attenuator steps.

The rectified crystal-mixer current produced by the oscillator signal in the TYPE 874-MR Mixer-Rectifier can be measured on the indicating meter. A knowledge of this current is important if attenuation measurements are to be made, since the oscillator voltage must be above a certain limit if the applied rf signal is large. The current is also an indication that the oscillator is functioning.

One of the internal power supplies operates the amplifier circuits; the other supplies heater and plate power to the heterodyning Unit Oscillator.

Modulation on the input frequency is amplified by a cathode follower and is available at the output terminals. The large meter has both linear and db scales for interpolation between attenuator steps.

#### TYPE DNT DETECTORS

Each assembly comprises one TYPE 874-MR Mixer Rectifier, one TYPE 1216-A Unit I-F Amplifier, one TYPE 874-G10 10-db Pad, one TYPE 874-EL 90° Ell, one Unit Oscillator and one filter depending on the frequency range desired (see price table).

The incoming signal and the signal from the Unit Oscillator are heterodyned in the Mixer Rectifier to obtain a 30-Mc difference frequency. This beat frequency is amplified and indicated on the meter of the TYPE 1216-A Unit I-F Amplifier. A block diagram of this method of detection is shown. Higher-frequency operation is obtainable by using oscil-



lator harmonics, but sensitivity is decreased, and care must be taken to avoid ambiguous beats. Both the fundamental and harmonic ranges are shown in the curves and the price table. Effective harmonic ranges (i.e., without overlap) are shown in the curves. The lowest harmonic covering the desired frequency should be used.

When wide ranges of frequency are to be covered, however, it is recommended that one complete DNT Detector be purchased, plus the necessary oscillators and filters for the additional frequency ranges desired. For instance, to cover the range from 40 to 950 Mc, one would order a TYPE DNT-2 Detector, plus one TYPE 1209-B Oscillator and one TYPE 874-F1000 Filter.



### FEATURES:

- Wide frequency ranges.
- High sensitivity.
- Excellent shielding.
- AVC for null detector use.
- Amplifier provides power for local oscillator.
- Broad bandwidth with good selectivity.
- Wide-range calibrated attenuator.

### SPECIFICATIONS TYPE 1216-A UNIT I-F AMPLIFIER

**Center Frequency:** 30 Mc.  
**Bandwidth:** Greater than 0.5 Mc at 3 db down; 9.5 Mc at 60 db down.  
**Sensitivity:** From a 400-ohm source, 2  $\mu$ volts input required for 1% meter deflection (above noise), 50  $\mu$ volts input for full-scale meter deflection. These are open-circuit source voltages.  
**Noise Figure:** Approx. 5 db.  
**Attenuator Range:** 0-70 db in 10-db steps.  
**Attenuator Accuracy:**  $\pm(0.3 \text{ db} + 1\%)$ .  
**Output Circuit Bandwidth:** (Modulation) 0.4 Mc.  
**Output Impedance:** 600 ohms.  
**Maximum Output Voltage:** 2 volts open circuit.  
**Terminals:** Input, TYPE 874 Connector on 2-foot cable; output,  $\frac{3}{4}$ -inch-spaced TYPE 938 Binding Posts.

**Supplementary Power Supply Output:** 300 volts dc at 30 ma; 6.3 volts ac at 1 amp. With this power supply, full output will not be obtained from a Unit Oscillator, but output is ample for heterodyne use.  
**Power Supply:** 105-125 (or 210-250) volts, 50 to 60 cps. Power input, 45 watts at full load. Can also be operated at 400 cps where line voltage does not drop below 110 v.  
**Tube Complement:** Two 6CB5; one each, 6AK5, 6AL5, 6U8, 0B2.  
**Accessories Supplied:** Spare fuses; three-wire power cord attached.  
**Mounting:** Gray crackle-finish aluminum panel and sides. Aluminum cover finished in clear lacquer.  
**Dimensions:** Width 10 $\frac{1}{4}$ , height 5 $\frac{3}{4}$ , depth 6 $\frac{1}{4}$  inches (260 by 146 by 159 mm) over-all.  
**Net Weight:** 8 $\frac{1}{4}$  pounds (3.8 kg).

### SPECIFICATIONS TYPE DNT DETECTOR

**Frequency Range:** See sensitivity curves; also price table.  
**Sensitivity:** See accompanying curves.  
**Mixer:** TYPE 874-MR Mixer-Rectifier (page 45).  
**Local Oscillator:** See pages 110 to 112 for specifications.

**Input Terminal:** Mixer input terminal is TYPE 874 Coaxial Connector. For connection to other types of coaxial connectors, see TYPE 874 Coaxial Adaptors, page 42. The TYPE 874-R22 Patch Cord (page 44) is also a convenient accessory.

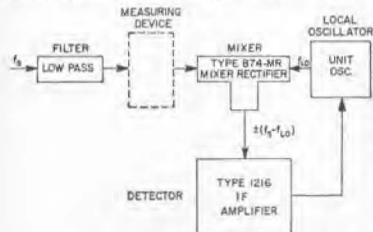

(Right) Frequency range and sensitivity of Type DNT Detectors for both fundamental and harmonic operation.

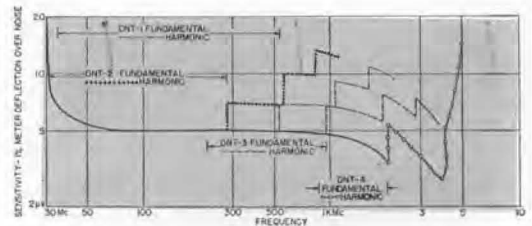

TYPE	FREQUENCY RANGE—MC				LOCAL OSCILLATOR TYPE NO.	FILTER SUPPLIED	CODE WORD	PRICE
	FUNDAMENTAL	2ND HARM.*	3RD HARM.*	4TH HARM.*				
DNT-1	40†-530	100-1030	165-1530	230-2030	1208-B	874-F500	NALTO	\$665.00
DNT-2	40†-280	70-530	120-780	170-1030	1215-B	874-F500	NERVO	645.00
DNT-3	220-950	470-1870	720-2790	970-3710	1209-B	874-F1000	NULTO	693.00
DNT-4	870-2030	1770-4030	2670-6030	Not recommended	1218-A	874-F2000	NODDO	898.00
1216-A	Unit I-F Amplifier						AMONG	340.00
480-P4U2	Relay-Rack Adaptor Panel for Type 1216-A						UNIPANBOLT	11.00

\* For harmonic operation, the appropriate low-pass filter must be used.  
 † 40 Mc is the practical low-frequency limit.  
 PATENT NOTICE. See Note 4, page viii.





## TYPE 1232-A TUNED AMPLIFIER AND NULL DETECTOR

**USES:** This sensitive, fully transistorized null detector tunes continuously over the frequency range from 20 cps to 20 kc, with additional spot coverage at 50 kc and 100 kc.

It is designed primarily for use as a bridge detector at these frequencies. Other important uses include:

A general-purpose audio amplifier ( $\pm 3$  db from 20 cps to 100 kc).

An amplifier for use with the TYPE 874-VQ Voltmeter Detector, for detection of high-frequency modulated signals.

A preamplifier for crystal microphones, vibration pickups, and other transducers, as well as for oscilloscopes.

An audio spectrum analyzer for approximate measurements.

**DESCRIPTION:** The circuit consists of a low-noise preamplifier, followed by a frequency se-

lective stage, and an amplifier-compressor stage. Tuning is accomplished by an RC network in a negative feedback loop. Input impedance is made equal to optimum source impedance so that noise output is independent of source impedance.

Meter scale can be either linear or compressed as controlled by a panel switch.

The assembly is housed in a rack-bench cabinet (page 242), normally supplied for bench use; panel extensions for relay-rack mounting are available.

### FEATURES:

- High sensitivity.
- High gain.
- High selectivity.
- Very low noise level.
- Continuous tuning.
- Long battery life.

### SPECIFICATIONS

#### Frequency Response:

**Tunable Filters:** 20 cps to 20 kc in 3 ranges; 6% bandwidth; 2nd harmonic at least 34 db down from peak, 3rd at least 40 db down; rejection filter on two highest ranges reduces 60-cycle level to at least 60 db below

peak. Frequency dial accuracy is  $\pm 3\%$ .

**50 kc and 100-kc Filters:** 2nd harmonic at least 60 db down.

**Flat Response:**  $\pm 3$  db 20 cps to 100 kc.

**Sensitivity:** See plot.

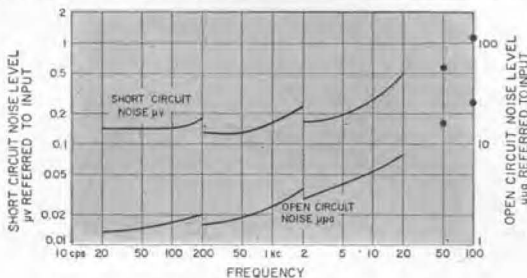

Typical noise levels as a function of frequency.

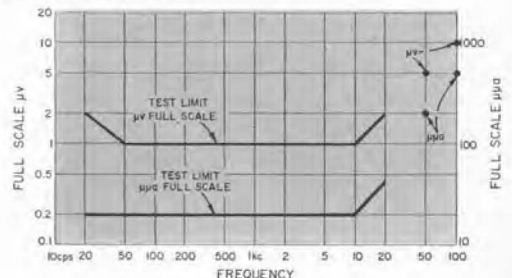

Sensitivity as a function of frequency.



**Noise Level:** Independent of source impedance; see plot.  
**Input Impedance:** Approximately 50 kilohms to one megohm, depending on gain-control setting.  
**Max Input Voltage:** 200 volts ac or 400 volts dc, without damage.  
**Gain:** 120 db on the tunable ranges; 100 db, flat range; 106 db at 50 kc; 100 db at 100 kc position.  
**Output:** 1 volt into 10,000 ohms. Internal impedance is 3000 ohms.  
**Meter Linearity:** Db differences on scale are accurate to  $\pm 5\%$  for inputs of less than 13 volts.  
**External Filter:** Source impedance, 700 ohms.

**Compression:** Reduces full-scale sensitivity by 40 db. Does not affect bottom 20% of scale.  
**Distortion:** (In flat position) less than 5%, practically all attributable to the meter rectifiers.  
**Power Supply:** 12 volts dc, from 9 mercury (M72) cells in series. Estimated battery life is 1500 hours. Cost is about 0.4 cent per hour.  
**Transistor Complement:** Six 2N169A, two 2N1395.  
**Accessories Supplied:** Type 874-R34 Patch Cord.  
**Dimensions:** Width 8, height 6, depth 7½ inches (205 by 150 by 190 mm) over-all.  
**Net Weight:** 5¾ pounds (2.6 kg).

TYPE		CODE WORD	PRICE
1232-A	Tuned Amplifier and Null Detector.....	VOCAL	\$360.00
480-P308	Relay-Rack Panel Extensions (Pair).....	EXPANELDOG	7.00 Pair

PATENT NOTICE. See Notes 4 and 15, page viii.



## TYPE 1212-A UNIT NULL DETECTOR

**USES:** This Unit Null Detector is an inexpensive, broad-band balance indicator for ac bridge measurements. It is a sensitive, wide-frequency-range voltage indicator with an approximately logarithmic relation between input voltage and meter reading. This null detector, with suitable input filters, can be used with the TYPE 1603-A Z-Y Bridge, TYPE 716-C Capacitance Bridge, TYPE 1632-A Inductance Bridge, TYPE 1661-A Vacuum-Tube Bridge, TYPE 916-AL R-F Bridge, TYPE 716-CS1 Capacitance Bridge, and up to 5 Mc with the TYPE 1606-A R-F Bridge.

**DESCRIPTION:** The instrument consists of a three-stage, broad-band amplifier with series-peaking compensation. Germanium-diode clip-

pers are used between stages to obtain the quasi-logarithmic input-output relationship.

### FEATURES:

- 50 cps to 5 Mc.
- Meter zero controllable from panel to correct for amplifier or system noise.
- Regulated tube voltages and balanced meter circuit maintain high stability.
- Meter sensitivity control provided for settings of voltage range desired.
- Headphone terminals provided.
- Miniaturized unit construction.
- On-scale range of approximately 120 db.
- Sensitivity increases as balance is approached — increases speed and precision.

### SPECIFICATIONS

**Sensitivity:** Less than 40 microvolts input at 1 kc is required to deflect meter one percent of full scale.

**Power Supply:** TYPE 1203-B or TYPE 1201-B Unit Power Supply is recommended (see page 137). Power supply



# DETECTORS

## NULL

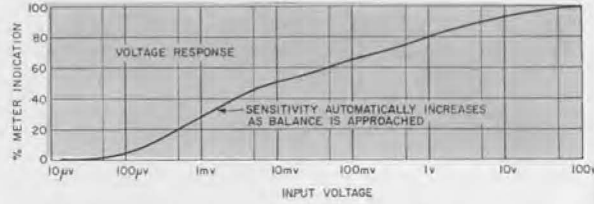
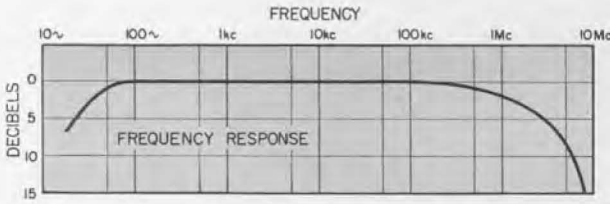

can be attached to detector to form a rigid unit by means of the locking strips supplied.

**Hum and Noise Level:** Hum, 20 μvolts; broad-band noise, 30 μvolts.

**Tube Complement:** Three 6AK5, one 12AX7, one 0A2.

**Accessories Supplied:** Power-supply plug and cable connector, locking strips.

**Accessory Filters Available:** TYPE 1212-P1, for eliminating low-frequency hum and noise, TYPE 1212-P2, for high selectivity at 1 Mc.

**Dimensions:** (Including power supply, as shown) width 15, height 5¾, depth 6¼ inches (381 by 146 by 159 mm) over-all.

TYPE		CODE WORD	PRICE
1212-A*	Unit Null Detector.....	ALACK	\$150.00
1203-B	Unit Power Supply (for 115-volt line)†.....	ALIVE	50.00
480-P4U3	Relay-Rack Panel (for amplifier and power supply)	UNIPANCART	12.00

\* PATENT NOTICE. See Notes 4 and 15, page viii.

† See page 137 for 230-volt supply.

## TYPE 1212-P1 HIGH-PASS FILTER



A shielded, RC high-pass filter designed to attenuate low-frequency noise and hum often encountered in bridge measurements. It provides about 50 db attenuation at 60 cps when used in conjunction with the TYPE 1212-A Unit Null Detector and fed from a low-impedance source.

**Nominal Load Impedance:** 1 megohm.

**Input Voltage Limit:** 150 volts maximum.

**Terminals:** TYPE 874 Connector at each end.

**Dimensions:** ¾ inch diameter by 4⅜ inches long (22 by 110 mm).

**Net Weight:** 3 ounces (85 g).

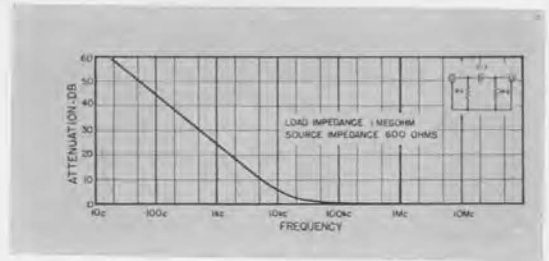

TYPE		CODE WORD	PRICE
1212-P1	High-Pass Filter.....	UNCLE	\$12.00

PATENT NOTICE. See Note 4, page viii.

## TYPE 1212-P2 1-MC FILTER

A shielded, tuned LC filter designed to attenuate both higher and lower frequencies, while providing insertion gain at 1 Mc.

**Insertion Gain:** When used with the TYPE 716-CS1 Capacitance Bridge and the TYPE 1212-A Unit Null Detector, the insertion gain at 1 Mc varies from 22 db to 32 db.

**Second Harmonic Rejection:** At least 39 db.

**Maximum Input Voltage:** 200 volts.



**Terminals:** TYPE 874 Connector at each end.

**Dimensions:** 2" diameter, 5" long (50 by 130 mm).

**Weight:** 9 ounces (0.26 kg).

TYPE		CODE WORD	PRICE
1212-P2	1-Mc Filter.....	ANNUL	\$30.00

PATENT NOTICE. See Note 4, Page viii.



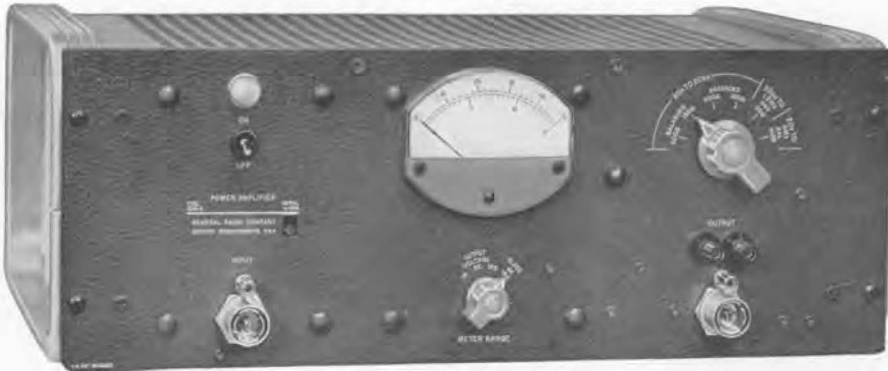

### TYPE 1233-A POWER AMPLIFIER

20 cps to 20 kc    20 kc to 1.5 Mc    20 cps to 3 Mc

**USES:** The wide frequency range and high power output of this amplifier make it adaptable to many uses in electronic and electro-acoustic laboratories. Typical uses are:

Driving acoustic generators.

Exciting antennas for radiation-pattern and impedance measurements.

Amplifying received signals for operating remote modulation and frequency monitors.

Amplifying weak signals for oscilloscope deflection.

**DESCRIPTION:** The excellent frequency response of this amplifier is obtained in three push-pull, broad-band circuits with series-peaked interstage couplings. The two power ranges use toroidal output transformers; the voltage-amplification range uses a series-peaked video-output network with gradual roll-off above 3 Mc. Ranges are selected by panel switch. Meter reads output volts and can be switched to read plate current of output tubes.

### SPECIFICATIONS

**Input Voltage:** Less than 0.2 volt for full output.  
**Input Impedance:** 100,000 ohms in parallel with 37 pf (grounded).  
**Power Supply:** 105 to 125 (or 210 to 250) volts, 40 to 60 cps; 120 watts at zero output; 140 watts maximum.

Instrument will operate with a maximum output of 10 watts on power-supply frequencies up to 400 cps. Three-wire power cord.

**Voltmeter:** Full-wave-average type; 150, 50, and 15 v, full scale; accuracy  $\pm 5\%$ , compensated to 3 Mc.

RANGE SWITCH POSITION	OPERATING FREQ. RANGE	OUTPUT POWER*	OUTPUT VOLTAGE	OPTIMUM LOAD IMPEDANCE	RISE TIME	DISTORTION AT RATED OUTPUT	NOISE LEVEL
20 c to 20 kc	20 cps — 20 kc 50 cps — 15 kc	8 watts 15 watts		600 or 150 $\Omega$		3%	60 db below 15 watts or equivalent to 200 $\mu$ v input.
20 kc to 1.5 Mc	20 kc — 1.5 Mc 20 kc — 0.5 Mc	8 watts 15 watts		50 $\Omega$ grounded		3%	70 db below 15 watts or equivalent to 63 $\mu$ v input.
20 c to 3 Mc	20 cps — 3 Mc		150 volts, peak-to-peak, bal; 50 volts grounded	CRO deflection plates; 1 M $\Omega$ , 36" leads	0.1 $\mu$ sec.	3%	Less than 0.6 v, peak-to-peak, bal, or equivalent to 600 $\mu$ v peak-to-peak input.
Disconnected	Any single frequency, 20 cps to 5 Mc	15 watts, with external tuned output transformer					

\* Rated output is obtainable at 105-volt line; output is greater for higher line voltages.

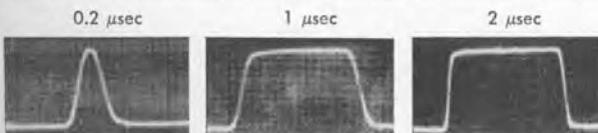

Output pulse waveforms 20 cps to 3 Mc range; input pulse rise time, .03  $\mu$ sec; three pulse lengths shown.



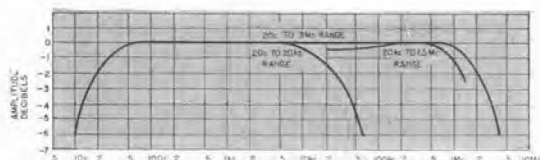

Typical response curves for the three amplifier ranges. The 20cps-to-3Mc range is given a smooth roll-off at the high end to assure good transient response.

**Tube Complement:** Two each, 6AC7, 6AG7, 807; one 6J6.  
**Terminals:** Input and output, TYPE S74 Coaxial Connectors with ground post for double-plug connection; TYPE 938 Binding Posts for balanced output.  
**Accessories Supplied:** Two TYPE 274-MB Double Plugs;

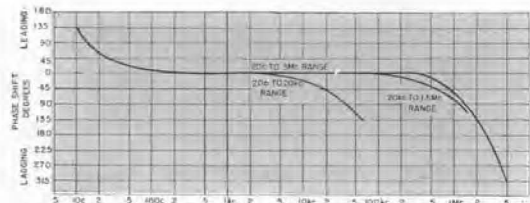

Phase shift versus frequency for Type 1233-A Power Amplifier.

two TYPE S74-C58 Cable Connectors; two spare line fuses; TYPE CAP-22 Power Cord.  
**Dimensions:** Width 19 $\frac{1}{8}$ , height 7 $\frac{1}{2}$ , depth 15 $\frac{1}{2}$  inches (495 by 190 by 395 mm) over-all.  
**Net Weight:** 46 $\frac{1}{2}$  pounds (21.5 kg).

TYPE	CODE WORD	PRICE
1233-A Power Amplifier	ANGER	\$625.00

PATENT NOTICE. See Note 4, page viii.

## TYPE 1206-B UNIT AMPLIFIER



This well-designed, compact amplifier delivers 3 watts at audio and ultrasonic frequencies. It has many uses in the laboratory — as a bridge amplifier, a driver for low-power electronic and electro-acoustic devices, and as an amplifier for use with the TYPE 1210-C Unit Oscillator. Single-ended, push-pull circuit produces excellent low-frequency response.

### SPECIFICATIONS

**Power Output:** With 300-volt plate supply, 600- $\Omega$  load: 3 watts from 10 cps to 50 kc; 1.5 watts from 5 cps to 100 kc; 0.5 watt at 250 kc.

**Distortion:** Less than 1% harmonic distortion with 2 watts output (2% with 3 watts) into 600 ohms from 20 cps to 40 kc.

Pulse Response:	NO LOAD	600 $\Omega$
Drop in 30-cycle square wave	15%	20%
Approx. Rise time: 50 v peak-to-peak	1 $\mu$ sec.	2 $\mu$ sec.
100 v peak-to-peak	2 $\mu$ sec.	4 $\mu$ sec.
Max output, peak-to-peak magnitude	260 v	120 v

**Load Impedance:** 600 ohms optimum. Blocking capacitor is 100  $\mu$ f. (Internal impedance about 100 ohms.)

**Input Impedance:** 100,000 ohms in parallel with 35 pf.

**Frequency Response:** Down less than 3 db at 2 cps and 500 kc at 10 volts (or less) output, with gain control set at maximum. See also power output specification.

**Voltage Gain:** Continuously adjustable. Maximum gain is 50 to 1 (34 db), with no load; 42.5 to 1 (32.6 db) into 600 ohms.

**AC Hum in Output:** Less than 15 mv, rms, with TYPE 1203-B Unit Power Supply; less than 3 mv, rms, with

TYPE 1201-B Unit Regulated Power Supply.  
**Power Requirements:** 6.3 volts, 2.7 amp; 300 volts, 50 ma.  
**TYPE 1203-B Unit Power Supply** is recommended.  
**Power Supply:** The amplifier plugs directly into any one of the Unit Power Supplies (pages 136 and 137). It can be rigidly attached with locking strips supplied, to form a complete assembly. The combination will operate satisfactorily from a 400-cycle supply.  
**Accessories Supplied:** Multipoint connector.  
**Tube Complement:** One 12AX7 and two 6W6-GT.  
**Terminals:** Jack-top binding posts with  $\frac{3}{4}$ -inch spacing.  
**Mounting:** Aluminum cabinet and chassis for bench mounting. Relay-rack panel adaptor available.  
**Dimensions:** Including power supply, width 15, height 5 $\frac{3}{4}$ , depth 6 $\frac{3}{4}$  inches (381 by 146 by 159 mm) over-all.  
**Net Weight:** 4 pounds (1.9 kg).



TYPE	CODE WORD	PRICE
1206-B* Unit Amplifier	ARBOR	\$85.00
1203-B Unit Power Supply (for 115-volt line)	ALIVE	50.00
480-P4U3 Relay-Rack Panel (for Amplifier and Power Supply)	UNIPANCART	12.00

\* PATENT NOTICE. See Notes 5, 9, and 14, page viii.

# FREQUENCY AND TIME



The determination of frequency directly in terms of time is a fundamental measurement, since frequency is the *time* rate of recurrence of cyclical phenomenon. The converse is also valid, since the time interval required for the occurrence of a given number of events of a fixed frequency is a constant quantity.

Axiomatically, the basis of frequency measurement is time measurement. All frequency measurements are specified in terms of events per unit time, usually in cycles per second. The discovery of atomic and molecular frequency standards, of presumably ultimate stability, has provided new means for calibrating standard frequencies and time intervals. International agreement has been obtained for Ephemeris Time (E.T.) as the basic constant time scale for scientific measurements. The Ephemeris second is defined as  $1/31,553,925.975$  of the tropical year 1900. The "tropical year" is the time between successive vernal equinoxes. However, Universal Time, also known as Greenwich Mean Time, based on the rate of rotation of the earth, is used for navigation and daily living. Hence, radio time signals and standard frequency broadcasts are now made on a time scale related to Ephemeris Time, but offset by an amount which produces approximate agreement with Universal Time. The internationally used Ephemeris Time scale is tentatively standardized with respect to the resonance frequency of the cesium atom at 9,192,631,770 cycles per second. The broadcast standard-time and frequency signals are offset by a stated number from the nominal E.T. value. This number has been  $-150 \times 10^{-10}$  in 1960 and 1961.

Astronomical time observations are carried out by national observatories throughout the world. Their measurements are made available to users through radio time-signal transmissions and by telegraph in their respective countries. In the United States, the U.S. Naval Observatory transmits time signals by radio through the facilities of the U.S. Naval Radio Service. Standard time signals monitored by the Naval Observatory are also broadcast continuously by the standard-frequency transmitters of WWV, operated by the National Bureau of Standards. A similar service is provided in Canada by the Dominion Observatory.

The user of a frequency standard equipped with means for measurement of the time of arrival of a radio time signal can then calibrate the frequency of the standard directly in terms of time. For the most precise result, the errors of the transmitted time signal must be taken into account. Correction data for this purpose may be obtained from the Superintendent, U.S. Naval Observatory, Washington 25, D.C. In addition, calibration accuracy depends on stability of propagation time from the transmitter to the receiving location. The variation in *high-frequency* propagation time is usually not less than  $\pm 0.1$  millisecond and may be greater. Hence, for a precision of calibration of  $\pm 1 \times 10^{-9}$ , a time interval longer than one day ( $1 \text{ day} = 8.64 \times 10^7$  milliseconds) is necessary between observations even if no additional instrumental errors are introduced. With the General Radio equipment described herewith, a time interval of two days should be adequate to obtain a calibration accurate to approximately  $\pm 1 \times 10^{-9}$ . Calibration to an accuracy of  $\pm 1 \times 10^{-10}$  will require several time determinations over a period of 15 to 20 days.

The "working" clocks used at the Naval Observatory are timed by piezo-electric oscillators of the type used in stable frequency standards. These oscillators are checked against astronomical observations and also against atomic frequency standards (whence derives

Atomic Time, A.T.). Through close cooperation between the National Bureau of Standards and the U.S. Naval Observatory, the time signals radiated by WWV and WWVH have been closely synchronized with the time signals transmitted by NBA on 18 kc. International agreement with Great Britain has likewise synchronized time and frequency broadcasts in the U.K. with United States signals. Since the time signals are derived from the stable oscillators controlling the carrier frequencies of these stations, their standard frequency values are similarly in agreement.

Standard-frequency broadcasts in the United States are primarily the responsibility of the National Bureau of Standards. Transmissions are made by stations WWV (Washington, D.C.), WWVH (Hawaii), and WWVB and WWVL (Boulder, Colorado). These transmissions are of the greatest possible stability and accuracy and represent a high-precision standard service wherever they can be received. It is important to note that WWVB (60 kc) and, especially, WWVL (20 kc) are intended to make use of the stable propagation conditions in the vlf band. For information and schedules of transmission of standard frequencies, apply to the Radio Standards Laboratory, National Bureau of Standards, Department of Commerce, Boulder, Colorado.

The U.S. Naval Radio Station NBA (Panama Canal Zone) on 18 kc also radiates on a standardized carrier frequency. The excellent geographic position of this

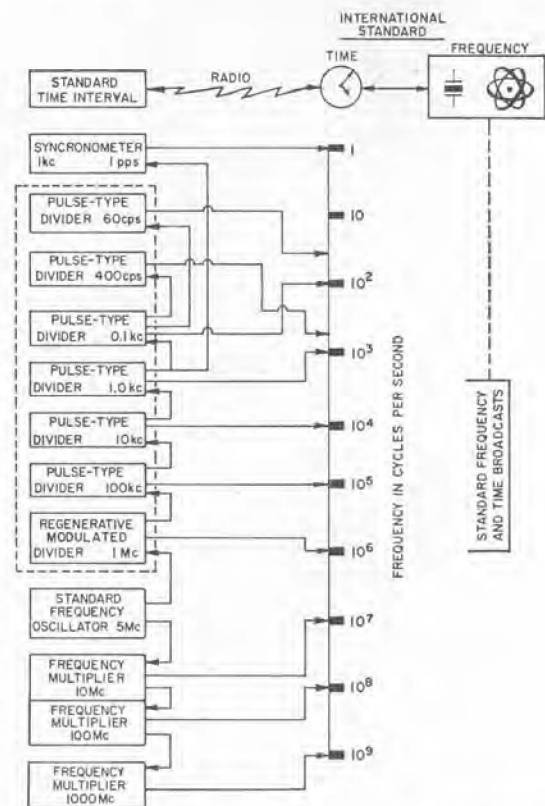

Figure 1. Block diagram of frequency standardization system.

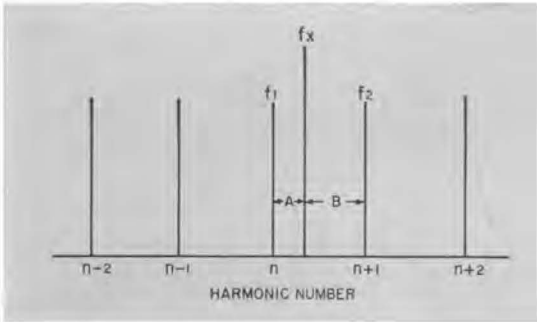

Figure 2. Relation between an unknown frequency and a series of standard-frequency harmonics.

station makes vlf standard time and frequency signals available over a large portion of the world.

### Frequency Measurement

An unknown frequency is measured by comparison with a known standard frequency. Several methods of carrying out this comparison are commonly used. In general, it is desirable to make use of a standard frequency that lies close to the unknown frequency and to measure the difference between the unknown and the standard frequency by an interpolation device. The relation between the standard and unknown frequencies is shown in Fig. 2. The heterodyne, analog, and digital interpolation systems are outlined in Figure 3. Since the human ear serves as a monitor in the heterodyne method, the calibrated audio oscillator need cover only up to a few kilocycles of range. The analog frequency meter and discriminator is direct reading in frequency, covering well beyond the audible range of beat frequencies. The digital counter frequency meter has a wide basic range, covering essentially zero to several tens of megacycles. Hence, the counter may operate directly to measure the unknown without requiring a detector unit if the signal is of adequate strength and purity. It requires a time base, however, which must be derived from the frequency standard if highest accuracy is required.

The heterodyne method is often used for the measurement of noisy, keyed, or remotely originating signals,

when monitoring of the signal is necessary to avoid incorrect measurements. The analog method serves for the measurement of oscillator drift or other frequency checking that may require otherwise tedious manual plotting of many individual readings, since the discriminator output may be used to operate a pen recorder. The digital counter permits high-resolution automatic measurement of frequencies within its basic range, requiring only that the signals be of suitable characteristics. Best results are obtained with continuous signals of local origin, with relatively clean spectrum of adequate amplitude. Above its direct resolution limit, some form of range extension will permit use of the counter as a precision interpolator. Further convenience is provided by the use of stable tunable oscillators as transfer oscillators. These calibrated oscillators assist in the measurement of intermittent signals and signals above the normal frequency range of the measurement system, as well as providing frequency-measuring devices of medium accuracy by the use of their calibrated dials.

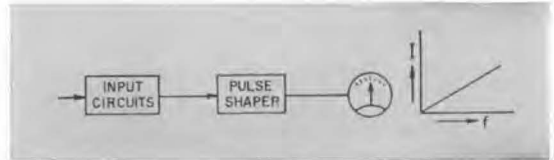

Figure 4. Elementary block diagram of an analog frequency meter.

### Maintenance of Calibrated Frequency Standards

For the greatest accuracy, it is desirable to intercompare two or more local frequency standards in order to provide assurance of proper functioning, and to determine the relative stability of the individual oscillators. General Radio frequency-standard equipment is specifically designed to facilitate establishment of such a two- or three-oscillator frequency standard. The TYPE 1113-A Standard Frequency Oscillator does not contain expensive frequency-divider elements that must be purchased if only the oscillator is desired. The TYPE 1114-A Frequency Divider can be easily transferred from one oscillator to another if, for any reason, it is desired to use the alternate source of driving signals. Intercomparison equipment for the checking and recording of frequency standard oscillator performance is described below.

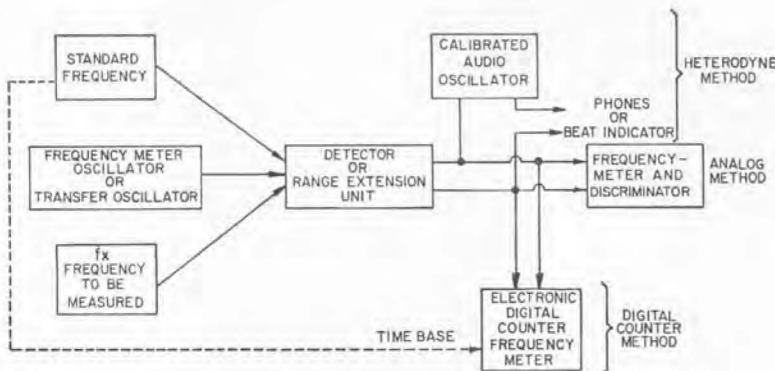

Figure 3. Measurement of the frequency difference between an unknown frequency and a nearby standard frequency.

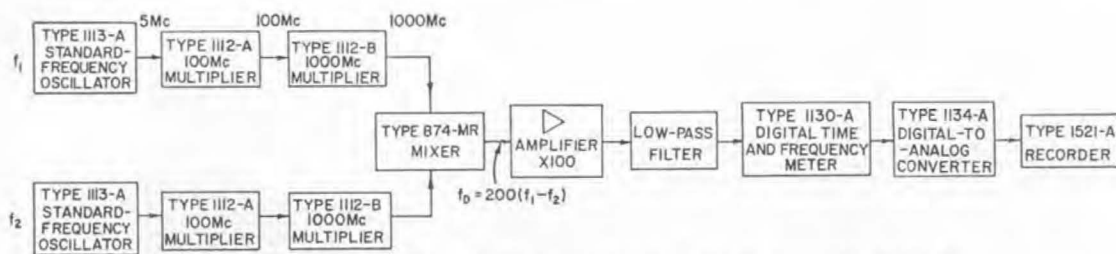

Fig. 6. System for intercomparison of two standard-frequency oscillators, by means of a digital frequency meter, to a resolution of  $\pm 1 \times 10^{-11}$ .

For the highest resolution intercomparison, two oscillators are put through separate multiplier chains, which produce output frequencies of 1000 Mc. The output of each multiplier is applied to a common mixer and the two signals are beat together. The beat note, which is produced when one oscillator frequency is slightly offset from the other, is amplified and applied to a digital period counter through a low-pass filter. The output of the digital counter is applied to a digital-to-analog converter, which selects the three most sensitive digits of the indication and supplies the required drive to a graphic recorder. Figure 6 is a block diagram of this system. The resolution of this system is approximately  $\pm 1 \times 10^{-11}$ , with a sampling time of approximately one-tenth second. In addition to the intercomparison feature, this assembly provides output signals up to 1000 Mc.

An intercomparison system of less resolution and lower cost is shown in block diagram form in Figure 7. It is useful for averaging times of 5 seconds or longer. The use of multiplier chains which produce 100-Mc output frequencies, together with the frequency meter-discriminator in its most sensitive operating range, i.e., the interpolation mode, produces a resolution of approximately  $\pm 0.1$  cycle per second, or  $\pm 1 \times 10^{-9}$  at 100 Mc. If a second frequency multiplier unit to 1000 Mc is added in each leg, the resolution can be increased to  $\pm 1 \times 10^{-10}$ . The availability of low-noise frequency multipliers, with appropriate mixers and radio-frequency coaxial fittings, makes it relatively easy to intercompare oscillators by multiplication of their frequencies and use of their difference frequency to operate frequency-measuring equipment and recorders. Combinations other than those illustrated are available and can be arranged to suit individual needs. In most cases, standard frequency signals will be provided for measurement purposes in the vhf-uhf and higher-frequency bands.

A table of contents for the instruments described in this section of the catalog is given at the right.

	PAGE
TYPE 1120 Frequency Standards . . . . .	68
TYPE 1113-A Standard Frequency Oscillators . . . . .	70
TYPE 1114-A Frequency Divider . . . . .	70
TYPE 1103-B Synchronometer . . . . .	71
TYPE 1112 Standard-Frequency Multipliers . . . . .	72
TYPE 1105-B Frequency-Measuring Equipment . . . . .	74
TYPE 1130-A Digital Time and Frequency Meter . . . . .	76
TYPE 1132-A Data Printer . . . . .	78
TYPE 1130-P Time-Base Units . . . . .	79
TYPE 1134-A Digital-to-Analog Converter . . . . .	80
TYPE 1131-P Counting Decades . . . . .	81
TYPE 1213-D Time/Frequency Calibrator . . . . .	82
TYPE 1142-A Frequency Meter and Discriminator . . . . .	83

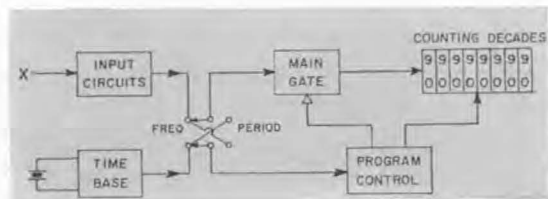

Figure 5. Elementary block diagram of a digital frequency meter (counter).

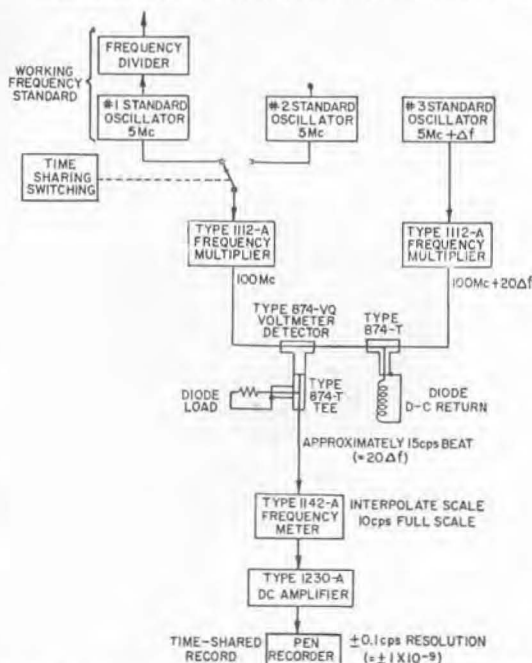

Figure 7. Alternate intercomparison system with analog frequency meter. Resolution is  $\pm 1 \times 10^{-9}$  as shown in this figure.



### TYPE 1120 FREQUENCY STANDARDS

The TYPE 1120 Frequency Standards are highly stable sources of standard-frequency signals. Standard-frequency output signals are available at decade intervals from 100 cps to 1000 Mc, as well as at 5 Mc, 60 cps, and 400 cps. The standard-frequency oscillator operates at 5 Mc, using a high-Q 5th-overtone-mode quartz crystal. A frequency-divider chain provides lower frequencies by means of a series of divider circuits in cascade. Frequencies above 5 Mc are produced in locked-oscillator-type, low-noise frequency-multiplier units.

The Synchronometer\* (synchronous motor clock) integrates the oscillator frequency and provides a time indication. By means of the built-in, precisely adjustable microdial contactor, the frequency of the oscillator can be compared with standard-time signals. Alternatively, the standard can be calibrated by comparison with standard-frequency broadcasts.

General Radio frequency standards, with associated measuring equipment, make excellent national standards of time and frequency for communications ministries. They are useful as frequency monitoring and measuring systems for checking the frequencies of radio transmitters. The high stability and low aging rate of the frequency of the 5-Mc oscillator makes it suitable for use as an observatory clock, with the frequency divider and Synchronometer.

A functional layout of the frequency standards is given on page 65 (Figure 1). The individual components are described on the following pages, as are the frequency-measuring systems developed for use with these standards.

General Radio Frequency Standards are known the world over for reliability and stability. They are used by governmental agencies, industrial plants, research laboratories and military services. Current models offer improved stability and a wider range of output frequencies than earlier designs. In addition, these standards offer the highest quality, low-noise, standard-frequency signals for uhf and microwave applications. The vhf and uhf signals are essentially free from submultiple output frequencies.

New techniques, circuits, and components have been used wherever applicable, consistent with conservative design. Practical compromises have been sought throughout to pro-



Type 1103-B  
Synchronometer

Type 1114-A  
Frequency  
Divider

Type 1113-A  
Standard-  
Frequency  
Oscillator

Type 1112-A  
Frequency  
Multiplier  
1-10-100 Mc

Type 1112-B  
Frequency  
Multiplier  
1000 Mc

Blank  
Panels  
to fill  
Rack

Type 1120-AH, 1000-Mc Frequency Standard

\*Trademark pending.



vide performance commensurate with the present state of the art at prices in keeping with equipment for everyday use. Thus, in accord with General Radio practice, the instruments are designed to be rugged, accurate, and dependable for ordinary environments but not to cope with the stringent requirements of the military services for extreme environmental conditions.

The individual components of the standard are available for special applications. Since the 5-Mc reference oscillator is a self-contained unit, it is possible to operate several oscillators for intercomparison checking without the purchase of unnecessary frequency dividers or other auxiliary equipment with each oscillator.

The separate frequency-divider and frequency-multiplier units may be purchased as required. It is a simple matter to provide multiple standard-frequency work areas by this means.

Each frequency-standard assembly is supplied in a floor-type relay rack. The panels and relay rack are finished in General Radio gray crackle lacquer. Space is available in the rack for addition of such auxiliary items as line-voltage regulators, emergency power supply units, radio receiving equipment and loudspeakers.

For a detailed description of the TYPE 1120 Frequency Standards, see R. W. Frank, F. D. Lewis, and H. P. Stratmeyer, "A Stable and Reliable Frequency Standard," *General Radio Experimenter*, 35, 4, April, 1961.

## SPECIFICATIONS

The performance specifications of these frequency standards are listed under the descriptions of the component units described in the following pages. Two models are available, TYPE 1120-A and TYPE 1120-AH.

### TYPE 1120-A Frequency Standard

#### Components:

- TYPE 1113-A Standard-Frequency Oscillator.
- TYPE 1114-A Frequency Divider.
- TYPE 1103-B Synchronometer.
- Floor-type relay rack.
- Blank panels to fill rack.
- Connection Cables.

**Output Frequencies:** 5 Mc, 1 Mc, 100 kc, 10 kc, 1 kc, 100 cps. Plug-in units for 400 cps and 60 cps are also available. See TYPE 1114-A Frequency Divider, page 70.

**Power Input:** 140 watts, maximum, at 105 to 125 (or 210 to 250) volts, 50 to 60 cps.

**Dimensions:** Width 22, height 76½, depth 18½ inches (560 by 1950 by 470 mm), over-all.

**Net Weight:** 82 pounds (37.5 kg).

### TYPE 1120-AH 1000-Megacycle Frequency Standard

#### Components:

- TYPE 1113-A Standard Frequency Oscillator.
- TYPE 1114-A Frequency Divider.
- TYPE 1103-B Synchronometer.
- TYPE 1112-A Frequency Multiplier.
- TYPE 1112-B Frequency Multiplier.
- Floor-type relay rack.
- Blank panels to fill rack.
- Connection cables.

**Output Frequencies:** 1000 Mc, 100 Mc, 10 Mc, 5 Mc, 1 Mc, 100 kc, 10 kc, 1 kc, 100 cps; optionally 60 cps and 400 cps (see page 70).

**Power Input:** 375 watts, maximum at 105 to 125 (or 210 to 250) volts, 50 to 60 cps.

**Dimensions:** Width 22, height 76½, depth 18½ inches (560 by 1950 by 470 mm), over-all.

**Net Weight:** 142 pounds (65 kg).

TYPE		CODE WORD	PRICE
1120-A	Frequency Standard .....	ENDOW	\$3640.00
1120-AH	1000-Megacycle Frequency Standard .....	ENJOY	6450.00

## TYPE 1116-A EMERGENCY POWER SUPPLY

An emergency power-supply unit is available to maintain continuous operation of a frequency standard comprising an oscillator, frequency divider, and clock unit. The TYPE 1116-A Emergency Power Supply furnishes ac power from storage batteries, the switch-over being accomplished automatically upon failure of the main ac supply. The transition to battery supply occurs without interruption of the continuous operation of the oscillator and timing system, so that calibration procedure involving time integration can be fully relied upon.

While the design of the TYPE 1113-A Standard-Frequency Oscillator prevents the possibility of permanent damage in the event of power failure, a period of hours or even days may be necessary for the standard to recover equilibrium after a temporary unsettlement caused by power failure.

The emergency power supply is, therefore, a recommended accessory for the frequency standard.



## SPECIFICATIONS

**Input:** 115 or 230 v, 50-60 cps from power line. 28-32 v, 10-7.5 amp from battery (when operating frequency standard).

**Output:** 115 v, nominal, 60 cps, 180 watts continuous.

**Accessories Required:** 28-, 30-, or 32-v battery.

**Dimensions:** Length 19 by height 10½ inches (485 by 270 mm), depth behind panel 13 inches (330 mm).

**Net Weight:** 58½ pounds (26.6 kg).

TYPE		CODE WORD	PRICE
1116-A	Emergency Power Supply .....	MUMMY	\$540.00





### TYPE 1113-A STANDARD-FREQUENCY OSCILLATORS



View of Type 1113-A Standard-Frequency Oscillator control panel. The front panel is held in place with two catches, and is easily removed for adjustment of controls or observation of oven performance.

This high-stability oscillator uses a 5-Mc, 5th overtone, AT-cut crystal in a modified Gouriet-Clapp circuit. A block diagram is shown. The drive level is held constant by automatic gain control. Negative feedback is used to hold the drive level variation to less than 10% for 2:1 changes in transconductance of the tubes.

A two-stage oven holds crystal and critical oscillator components at constant temperature. The outer stage operates at about 57 C, the inner stage at the temperature of zero temperature-coefficient of the crystal. This temperature varies between units and is between 70 and 80 C.

Both plate and heater voltage are regulated. Long-life, premium-quality tubes are used in the oscillator and amplifier.

**FEATURES:**

- Excellent short- and long-term stability.
- DC on tube heaters for lowest possible FM.
- Frequency can be set to  $1 \pm 10^{-10}$ .
- Five-point meter circuit to check all important operating characteristics.

### SPECIFICATIONS

**Frequency Stability:**

**Aging:** Less than  $5 \pm 10^{-10}$  per day, averaged over 10 days, after 60 days of operation. After 1 year of operation typical drift is less than  $2 \times 10^{-10}$  per day.

**Short-Term:** Better than  $1 \times 10^{-10}$  per minute, as measured with 1-second samples.

**Oven Cycling:** Less than  $1 \times 10^{-10}$  peak to peak.

**Ambient:** Less than  $1 \times 10^{-10}/^{\circ}\text{C}$  ( $5 \times 10^{-9}$  for 0-50 C).

**Line:** Less than  $1 \times 10^{-10}$  for 105-130 volts.

**Loading:** Less than  $\pm 2 \times 10^{-10}$  for  $50\Omega \pm 20\%$ .

**Frequency Adjustments:**

**Coarse:** Approximately  $500 \times 10^{-9}$ .

**Fine:**  $\pm 5 \times 10^{-9}$  in divisions of  $5 \times 10^{-10}$ .

**Settability:** To  $1 \times 10^{-10}$ .

**Outputs:** 1 v rms into  $50\Omega$  at 5 Mc, 0.4 v rms for General

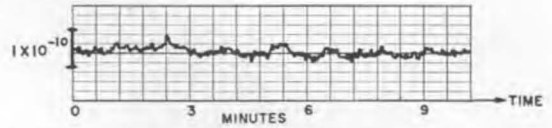
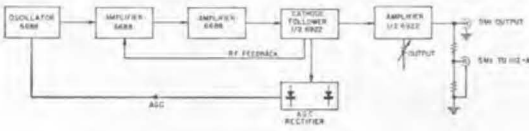

Intercomparison of frequencies of two Type 1113-A Standard-Frequency Oscillators. The short-term instability of one oscillator alone is less than the combined instability by  $1/\sqrt{2}$ . Sampling period is one second.

**Radio TYPE 1112-A Frequency Multiplier.**

**Power Input:** 105-125 (or 210 to 250) volts, 50 to 60 cps, 100 watts, maximum.

**Tube Complement:** One each, 6AN8, 6AV5GA, 5965, 5727, 5651, 6922/E88CC; three 6688/E180F.

**Transistor Complement:** One each, 2N1138, 2N1372, two 2N445A.

**Dimensions:** Panel, 19 by  $5\frac{1}{4}$  inches (485 by 135 mm); depth behind panel, 16 inches (410 mm).

**Net Weight:** 30 pounds (13.6 kg).

### TYPE 1114-A FREQUENCY DIVIDER



Rear view of the frequency divider, showing the plug-in units.

The frequency divider operates from the 5-Mc output of the standard-frequency oscillator to produce output frequencies of 1 Mc, 100 kc, 10 kc, 1 kc, and 100 cps; optionally, outputs of 400 cps and 60 cps are also

available. The 5-Mc-to-1-Mc divider is a regenerative type; all others are switching types. All circuits are "fail-safe". There is no output when the input signal is absent. Output of all divider stages is sine wave, with square waves also available at 10 kc and 100 kc.

All divider units are plug-in modules.

**FEATURES:**

- Wide range of output frequencies.
- Fail-safe operation.
- Very low jitter.

### SPECIFICATIONS

**Transistor Complement:** One each 2N645 and 2N1218, two 2N1396, three 2N1372, four 2N520, seven each 2N169A and 2N582, fifteen 2N404, and sixteen 2N1374.







**Input:** 5 Mc, 1 Mc, 100 kc, 50Ω. 1 v ±50%.  
**Output (with 5-Mc input):** 5 Mc.

**Sine Waves:**

1 Mc	} 1 v	{ +50%	{ -10%	} into 50Ω
100 kc				
10 kc	} 1 v	{ +50%	{ -10%	} into 600Ω
1 kc				
100 cps				

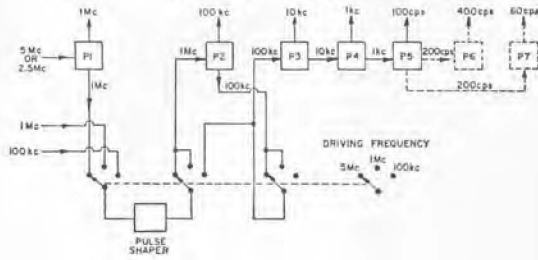

View of typical plug-in unit.

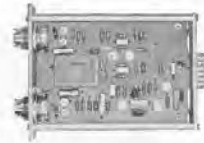

\*400 cps } 1 v { +50% } into 600Ω  
 \*60 cps } 1 v { -10% }

\* Optional accessories

**Square Waves:** 100 kc } Approximately 7 v peak-to-peak  
 10 kc } peak open circuit

**Spurious Signals:** Better than 34 db down.  
**Jitter:** Less than 0.5 nsec for 100-c output with respect to 5-Mc input.

**Power Input:** 105 to 130 (or 210 to 260) volts, 50 to 400 cps; approximately 7 watts.

## TYPE 1103-B SYNCHRONOMETER \*



The TYPE 1103-B Synchronometer is a precision clock with 24-hour dial for the calibration of frequency and time standards. The 100-tooth phonic-wheel motor is driven by a 1-kc standard-frequency signal at 10 revolutions per second. A worm-and-gear reduces this to 1 revolution per second at a shaft which carries a cam operating a phaseable contactor. The contactor operating time, or phase, is adjustable, to any time setting within the second (one revolution). The contactor set-

\*Trademark pending.

ting is indicated by a three-wheel digital microdial indicator reading directly in milliseconds with graduations at 0.2-millisecond intervals, which can be read accurately to ±0.1 millisecond. The stability of the closing time of the contactor is ±0.1 millisecond. The variation in time of arrival of time signals in the hf band is generally of comparable magnitude. Time comparison by this method may yield a frequency-calibration accuracy of ±1 × 10<sup>-9</sup> over a 48-hour interval.

The Synchronometer is a constant monitor of the continuity of operation of the frequency standard, as well as of the proper functioning of the divider chain. If the clock driving signal is interrupted or changes frequency momentarily, or if the power supply fails, the clock stops and requires restarting. The entire mechanism is simple and reliable, and will give years of service with minimum maintenance.

### FEATURES:

- Time-of-arrival readings can be made without disturbance of the indicated time on the clock.
- The 1000-cycle synchronous motor is started from the front panel through push-button control of the 60-cycle starting motor.

## SPECIFICATIONS

**Input:** 1000-cycle sine wave, one volt into 50,000 ohms.

**Microdial Contactor Stability:** Maximum contact closing time deviation at any microdial setting is ±0.1 msec.

**Calibration Errors:** The maximum deviation between the indicated microdial setting and the actual contactor closing time varies sinusoidally from 0 to ±1 msec (maximum) over the 1000-msec range.

**Accuracy of Time Increments:** The maximum error over a time interval of 25 msec is ±2% ±0.1 msec.

**Power Input:** 105 to 125 (or 210 to 250) volts, 50 to 60 cps; 22 watts, continuous; 10 watts additional for starting motor.

**Dimensions:** Panel, 19 by 8¾ inches (485 by 225 mm); depth behind panel, 11 inches (280 mm).

**Net Weight:** 35 pounds (16.0 kg).

TYPE	CODE WORD	PRICE
1113-A Standard-Frequency Oscillator . . . . .	ALLOT	\$1550.00
1114-A Frequency Divider . . . . .	ADOWN	950.00
1114-P6 400-Cycle Plug-in Unit . . . . .	CAMEL	85.00
1114-P7 60-Cycle Plug-in Unit . . . . .	CALIF	115.00
1103-B Synchronometer . . . . .	AUDIT	900.00



TYPE 1112-A  
1, 10, 100 MC

## TYPE 1112 STANDARD-FREQUENCY MULTIPLIERS

**USES:** The TYPE 1112 Standard-Frequency Multipliers generate sine-wave signals of 1, 10, 100, and 1000 megacycles per second when driven from a 100-ke or 1-Mc source. Alternatively they can be driven from a source of 1, 2.5, or 5 Mc, with the 1-Mc output inoperative. They greatly extend the useful range of crystal-controlled frequency standards, such as the General Radio TYPE 1120.

The output frequencies can be used to generate harmonic series, by means of simple crystal multiplier and mixer circuits, to provide standard frequencies throughout the microwave spectrum for the precise measurement of frequency.

The unusually low noise and excellent phase stability of the output frequencies make possible the intercomparison of lower-frequency standard-frequency oscillators for stability measurements, and the comparison of crystal standards with cesium-beam or other atomic standards.

**DESCRIPTION:** The remarkable phase stability and noise-reduction properties of these multipliers result from the use of a narrow-band filter to select only the desired output harmonic at each output frequency.

Quartz-crystal filters are used in the TYPE 1112-A Multiplier, since they afford the highest possible  $Q$ , and hence narrowest bandwidth, in this frequency range. In order to maintain these crystal filters at the correct resonant frequency, each crystal is incorporated in an oscillator circuit whose frequency is phase-locked to the desired harmonic frequency by an automatic-phase-control loop. As shown in the block diagram, the 100-ke input signal is multiplied to 1, 10, and 100 Mc, each of which is compared in a phase detector to a crystal oscillator of the same nominal frequency. The output of the phase detector corrects the frequency of the oscillator through a reactance tube. The narrow bandwidth of the feedback loop minimizes frequency-modulation noise.

The TYPE 1112-B Standard-Frequency Multiplier operates from a separate 100-Mc output of the TYPE 1112-A. A phase-locked klystron oscillator is used as a selective filter to eliminate unwanted harmonics of the control frequency, operating in much the same manner

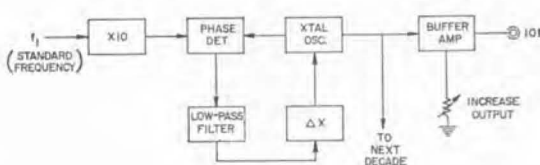

TYPE 1112-A

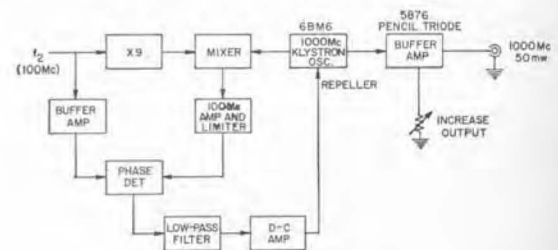

TYPE 1112-B



TYPE 1112-B  
1000 MC



as the locked crystal oscillators in the lower-frequency unit. The over-all multiplying factor of 10 is obtained by multiplying 3 x 3 and adding 1. Since, however, the Q of the klystron resonator is not extraordinarily high, the phase-modulation noise inherent in klystrons is reduced by means of negative feedback. The automatic-phase-control loop for the 100-Mc klystron feeds back phase noise over a wide frequency band to reduce phase instability;

the reference standard is the multiplied harmonic of the crystal-controlled 100-Mc driving signal.

### FEATURES:

- Extremely low noise.
- Excellent stability.
- 20-mw output (50 mw at 1000 Mc).
- Makes possible standard frequencies in the microwave range.

### SPECIFICATIONS

#### TYPE 1112-A

**Spurious Signals:** Unwanted harmonics of the input frequency are at least 100 db below the desired output frequency.

**Frequency-Modulation Noise:** Less than  $\pm 1 \times 10^{-9}$  residual noise.

**Locking Range:** The input signal can drift  $\pm 15$  parts in  $10^6$  before the locked oscillator goes out of control.

**Bandwidth:** (Expressed as allowable frequency-deviation rate)

Decade	Approx Bandwidth in cps at Input Frequency
100 ke-1 Mc	50
1 Mc-10 Mc	500
10 Mc-100 Mc	5000

**Input:** 1 volt, 100-ke sine wave from standard-frequency oscillator. Can also be driven at input frequencies of 1 Mc (1.5 v), 2.5 Mc (0.4 v), or 5 Mc (0.4 v). Will run free with no input signal, but absolute frequency may be in error by several parts per million.

**Output:** Four channels; one each of 1 Mc and 10 Mc, and two of 100 Mc; all sine wave; all 50 ohms; 20 milliwatts, max., into 50 ohms.

**Open-Circuit Output Voltage:** Approximately 2 volts.

**Terminals:** TYPE 874 Coaxial Connectors; adaptors are available to fit all commonly used connector types.

**Power Supply:** 105 to 125 (or 210 to 250) volts, 50 to 60 cps, 110 watts.

**Accessories Supplied:** TYPE CAP-22 Power Cord, TYPE 874-R22 Patch Cord, two TYPE 874-C58 Cable Connectors, spare fuses.

**Tube Complement:** Three 6AN8; two each 6AU6, 6X8, 6C4, 6BC5, 6CY5; one each 6080, 12AX7, 5651.

**Dimensions:** Relay-rack panel, 19 by  $12\frac{1}{4}$  inches (480 by 330 mm); depth,  $11\frac{1}{2}$  inches (310 mm).

**Net Weight:** 25 pounds (11.5 kg).

#### TYPE 1112-B

**Input:** 20 milliwatts, 100 Mc, sine wave from TYPE 1112-A Standard-Frequency Multiplier; 50-ohm input impedance.

**Output:** 1000-Mc sine wave; 50 mw into 50-ohm load; 50-ohm output impedance.

**Locking Range:**  $\pm 100$  ke at the input frequency.

**Bandwidth:** Allowable frequency deviation rate is 100,-000 cps at the input frequency.

**Tube Complement:** Three each 6AG5, 6AU5GT, 12AX7, 5651; two 6AK5, one each 6J6, 6AU6, 5876, 6BM6.

**Power Input:** 125 watts.

**Accessories Supplied:** TYPE CAP-22 Power Cord, TYPE 874-C58 Cable Connector, two TYPE 874-R22 Patch Cords, spare fuses.

**Net Weight:** 35 pounds (16 kg).

Other specifications are identical with those for TYPE 1112-A, above.

TYPE		CODE WORD	PRICE
1112-A*	Standard-Frequency Multiplier.....	EPOCH	\$1450.00
1112-B	Standard-Frequency Multiplier.....	EPODE	1360.00

\* PATENT NOTICE: See Notes 2 and 4, page viii.

For a complete description of these instruments, see the *General Radio Experimenter*, 32, 10, July, 1958.





## TYPE 1105-B FREQUENCY MEASURING EQUIPMENT

The TYPE 1105-B Frequency Measuring Equipment is a heterodyne-method frequency measurement system. The method of operation is based on the principles set forth in Figure 2 and Figure 3 on page 66. Harmonics of the 10-ke and 100-ke standard frequencies are generated by a newly developed avalanche-transistor pulse generator, which produces strong harmonics to 100 Mc and beyond. It is thus possible to make direct measurement of frequencies up to 100 Mc using the TYPE 1107-A Interpolation Oscillator and the TYPE 1109-B Comparison Oscilloscope as the beat-frequency interpolator to measure beat note "A" in Figure 2. Each TYPE 1106 Frequency-Transfer Unit contains a regenerative detector and calibrated transfer oscillator covering a portion of the spectrum. They are interconnected with the unknown signal and the frequency standard through the TYPE 1108-B Coupling Panel which contains the transistor pulse generators for producing the standard-frequency harmonics.

In the frequency range from 100 kc to 100 Mc, the approximate frequency is read from the dial of the detector, a more exact value from the heterodyne frequency meter (transfer oscillator) scale; and the beat note of the unknown signal against the standard-frequency harmonic is measured by setting the direct-reading dial of the audio interpolation oscillator to produce a stationary pattern on the oscilloscope. The availability of the transfer oscillators in the same units as the detectors makes it possible to generate precisely known frequencies between 100 kc and 100 Mc. The oscillators cover fundamental frequency ranges from 100 to 200 kc (1106-A), 1000-2000 kc



(1106-B), and 10-20 Mc (1106-C), other frequencies being generated as harmonics of those fundamental ranges.

Provision is made for use of an external radio receiver to receive signals for which either the sensitivity or selectivity of the heterodyne detector units is not considered adequate, or to cover the frequency range above 100 Mc. The standard-frequency harmonics extend beyond 100 Mc with adequate amplitude for use with sensitive receivers up to approximately 150 Mc.

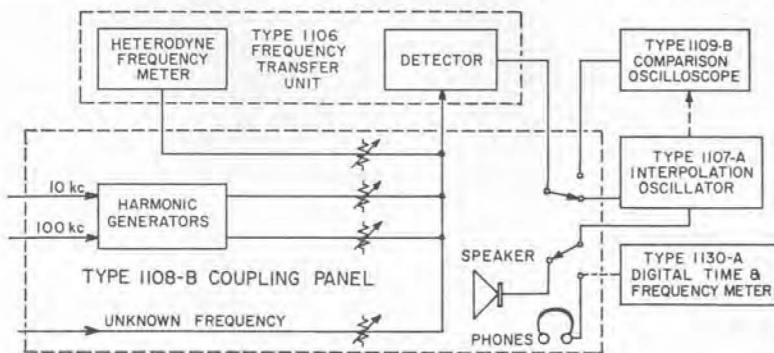

Block diagram of the Type 1105-B Frequency Measuring Equipment.

TYPE	CODE WORD	PRICE
1105-B	MITER	\$5900.00

PATENT NOTICE, See note 4, page viii.





## TYPE 1109-B COMPARISON OSCILLOSCOPE

This unit contains a cathode-ray oscilloscope, with its power supply; selecting, smoothing, and phaseshifting networks for circular sweeps at line frequency, 0.1, 1 and 10 kc standard frequencies, and at a variable frequency obtained from the interpolation oscillator; and a selector providing for all necessary and convenient comparisons required in making frequency measurements. Most patterns are presented on a circular sweep by radial deflection. **\$600.00**



## TYPE 1106-A, -B, -C FREQUENCY-TRANSFER UNITS (3 Panels)

Each of these units contains a heterodyne frequency meter and heterodyne detector, with direct-reading scales. Ranges are as follows:

TYPE 1106-A	100 kc to 2000 kc
TYPE 1106-B	1 Mc to 10 Mc
TYPE 1106-C	10 Mc to 100 Mc

The harmonic output of the frequency meter can be used at frequencies higher than those covered by the dial ranges, as explained in the operating instructions. The output of the frequency meter is adjustable by a panel control, as is the regeneration of the heterodyne detector. **Each model, \$1050.00**



## TYPE 1108-B COUPLING PANEL

This unit is the centralized control point at which all switching and level adjustments necessary for using the various combinations of measuring equipment can be easily and quickly carried out. Also generates harmonics from the standard-frequency inputs of 10 and 100 kc. **\$510.00**



## TYPE 1107-A INTERPOLATION OSCILLATOR

This unit is a linear-scale, direct-reading, audio-frequency oscillator covering frequencies from 0 to 5000 cps. It is used to measure the audio-frequency difference between the unknown frequency and a standard 10-kc harmonic. Provision is made, on two scales, so that results can be obtained by addition only, avoiding subtraction. A mixer circuit is provided with controls for output of the interpolator and for the unknown frequency, so that a maximum beat amplitude can be obtained. A meter indicates output voltage and can be used as a beat indicator for matching the interpolator and unknown frequencies. **\$1070.00**



## TYPE 480-MA RELAY RACK

The individual units, with the exception of the TYPE 1107-A Interpolation Oscillator, are mounted in the TYPE 480-MA Relay Rack. At the base of the rack is

mounted a TYPE 1105-P1 Speaker for audible monitoring of beat tones.

All connections between standard and measuring assembly are made by means of patch cords, which are supplied.

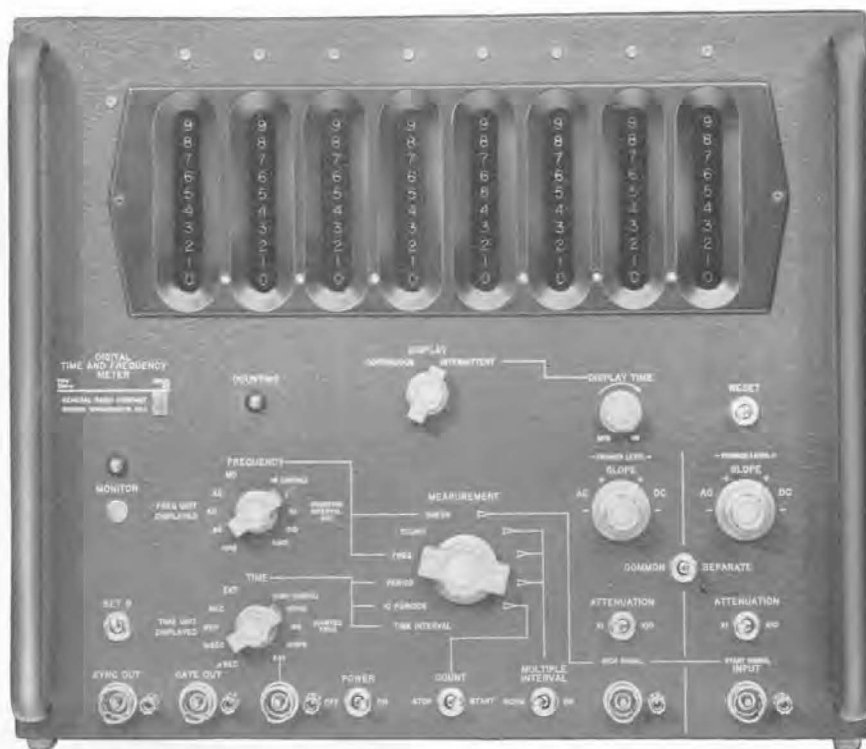

## TYPE 1130-A DIGITAL TIME AND FREQUENCY METER

**USES:** The Digital Time and Frequency Meter is an automatic instrument for the precise measurement of frequency, period, and time intervals. It can also count random events, measure frequency ratios, compute phase shift, and measure characteristics of pulse waveforms.

Because it is designed for maximum reliability, this counter is particularly suited to applications where unailing operation over long periods is required.

This counter has a built-in information storage system, which permits the operator to read the register at any time. This continuous display not only reduces operator eyestrain, but also makes more efficient use of the counting time interval.

**DESCRIPTION:** The simplified block diagram on page 77 shows the elements of the counter, which contains five basic circuit blocks: the Input Circuits, the Time Base, the Main Gate, the Program Control, and the Decimal Counting Units. The Input Circuits are used to generate trigger pulses from the input signal. During frequency measurement, the trigger pulses pass through the Main Gate and are

registered by the Decimal Counting Units. The Program Control holds the Main Gate open for a standard time interval of 0.001, 0.01, 0.1, 1.0, or 10 sec prescribed by the Time Base. A Multiple-Interval control allows the Measurement time to be extended beyond 10 sec. The Program Control also controls the display mode and handles the various resetting operations. For time measurements, (Period, 10 Periods, and Time Interval), the Program Control holds the Main Gate open for a time interval, determined by the Input Circuits from the input signal, while standard clock pulses from the Time Base of 10 Mc, 100 kc, 1 kc, or 10 cps are registered in the Decimal-Counting Units. A detailed description of the individual circuits and their operation has been published.\* Of particular interest to the discerning user are the following:

1. The decimal counting units use a non-critical 1-2-4-2 weighting, rather than the customary 1-2-2-4, to minimize the effects of changes in operating voltages and tube characteristics. These units operate reliably with half-dead tubes.

\*R. W. Frank and H. T. McAleer, "A Frequency Counter with a Memory and with Built-In Reliability", *General Radio Experimenter*, 35, 5, May, 1961. Reprints available





2. Computer-type design and premium components are used throughout.

3. All tube circuits are on plug-in boards, easily detached for service or replacement.

4. Time-base units also plug in. Four different types are available. A monitor lamp indicates loss of standard-frequency drive or any failure of the time base.

5. The measurement display consists of digital neon-lamp columns. The operator can choose either an 8-digit intermittent, or sequential, display, or a 4-digit continuous display. By proper setting of the Frequency or Time controls any 4 consecutive digits may be selected for continuous display. An illuminated decimal point is automatically positioned for each measurement, and the units of measurement are clearly indicated.

6. Controls are logically placed and clearly marked — easily operated by unskilled personnel.

## FEATURES:

- Designed-in reliability.
- Modular construction — Easy to service.
- Continuous display — no blinking lights.
- No time-base adjustment.
- Versatile input circuits — high sensitivity, high impedance, wide dynamic range, adjustable trigger level.

## SPECIFICATIONS

### FREQUENCY MEASUREMENT

**Range:** Dc to 10 Mc.

**Sensitivity:** 0.25 volt rms for sine waves, more sensitive at low frequencies; 0.4 volt peak-to-peak for typical pulse waveforms.

**Counting Interval:** 1 msec to 10 sec, extendible by MULTIPLE INTERVAL switch or external connections.

**Accuracy:**  $\pm 1$  count  $\pm$  time-base oscillator accuracy (see page 79).

### PERIOD MEASUREMENT

**Range:** 10  $\mu$ sec to  $10^7$  sec (dc to 100 kc) for single-period measurement, 330  $\mu$ sec to  $10^7$  sec (dc to 30 kc) for ten-period measurement.

**Sensitivity:** 0.1 volt rms for sine waves; 0.3 volt peak-to-peak for typical pulse waveforms.

**Counting Interval:** 1 period, 10 periods, extendible by MULTIPLE INTERVAL switch or external connections.

**Counted Frequency:** 10 Mc, 100 kc, 1 kc, 10 cps or External (6 volts rms sine waves, or  $\pm 10$  volts peak pulses, 100 cps to 10 Mc).

**Accuracy:**  $\pm 0.1\%$  at 1 volt rms for single-period measurement; better for higher voltage level and good signal-to-noise ratio.  $\pm 0.01\%$  at 1 volt rms for 10-period measurements; better for higher voltage level and good signal-to-noise ratio.

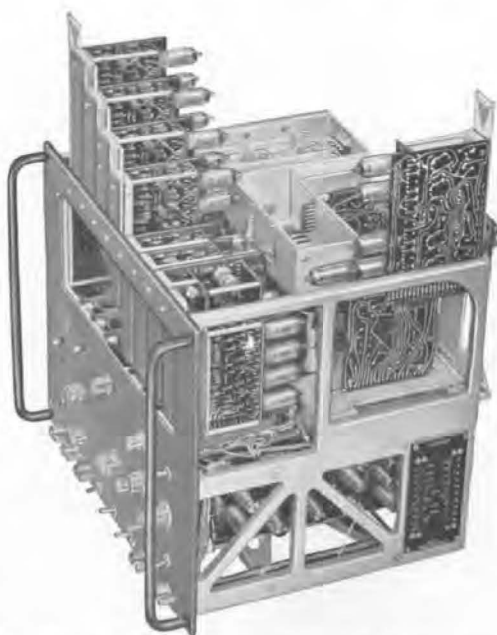
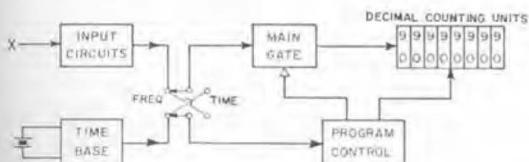

View of the Counter with cabinet removed, showing how the etched boards are easily removed for test or replacement.

- Multiple-interval measurements.
- Simplified graphic recording.

### TIME-INTERVAL MEASUREMENT

**Range:** 1  $\mu$ sec to  $10^7$  sec.

**Sensitivity:** 0.3 volt peak-to-peak.

**Counted Frequency:** 10 Mc, 100 kc, 1 kc, 10 cps, or External (6 volts rms sine waves, or  $\pm 10$  volts peak pulses, 100 cps to 10 Mc).

**Accuracy:** Dependent on slope of input signals at trigger point. For steep slopes (e.g., pulses);  $\pm 1$  period of frequency counted  $\pm$  accuracy of frequency counted.

### COUNT MEASUREMENT

**Rate:** Dc to 10 Mc.

**Sensitivity:** 0.25 volt rms for sine waves, more sensitive at low frequencies; 0.4 volt peak-to-peak for typical pulse waveforms.

**Capacity:**  $10^8$  counts.

### GENERAL

**Display:** Neon-lamp columns — 8 digits intermittent, 4 digits continuous.

**Display Time:** Variable, 0.1 to 10 sec, infinite, or continuous display.

**Input Impedance:** 1 megohm shunted by 40 pf.

**Input Attenuator:**  $\times 1$  or  $\times 10$ .

**Check:** 10 cps, 1 kc, 100 kc, or 10 Mc can be counted for 1 msec to 10 sec.

**Monitor:** Flashing lamp indicates lack of time-base drive signal or improper operation of frequency dividers.

**Input Trigger Level:** Adjustable  $\pm 10$  volts.

**Input Trigger Slope:** Positive-going or negative-going, ac or dc coupling.

**External Outputs, Front Panel:** GATE signal (coincides with the counting interval); SYNC pulses (at start of internal program cycle); 10 cps to 10 Mc (except 1 Mc) standard frequencies from EXT connector, depending on





## PRINTER

settings of MEASUREMENT, FREQUENCY and TIME controls.

**External Outputs, at rear:** MULTIPLE-INTERVAL and RESET connections, carry output pulse; 8, four-line, binary-coded-decimal digits (1-2-4-2) ("0" = 185 volts, "1" = 65 volts — 0.5 megohm source impedance — minimum load impedance 1.8 megohms).

**Time-Base Drive Required:** 5 Mc, 1 volt rms into 50 ohms (supplied by 1130-P2, -P3, -P4, 1113-A, see page 79).

**Power Input:** 105 to 125 (or 210 to 250) volts, 50-60 cps, 400 watts.

**Ambient Temperature Range:** 0 to 50 C.

**Tube Complement:** Forty-one 5963; twenty 6922; eleven 6887; ten 5965; five 6350; three each 5915, 6AU6; one each 5651, 12AT7, 12AX7.

**Accessories Supplied:** Power cord, spare fuses, 4 TYPE 874-C62 Cable Connectors, TYPE 1130-47 Plug.

**Accessories Available:** Additional time-base units (page 79); TYPE 1132-A Data Printer (below); TYPE 1134-A Digital-To-Analog Converter (page 80); spare or replacement counting decades (page 81), TYPE 1130-P5 Servicing Accessory (page 79) for operating any one of the etched-board assemblies outside the cabinet.

**Dimensions:** Width 19, height 16 1/4, depth 19 1/4 inches (485 by 415 by 490 mm), over-all.

**Net Weight:** 85 pounds (39 kg).

TYPE		CODE WORD	PRICE
1130-AM1	(Including Type 1130-P1 Time-Base Unit) <b>Bench Mount</b> .....	LABOR	\$2585.00
1130-AR1	(Including Type 1130-P1 Time-Base Unit) <b>Rack Mount</b> .....	MINIM	2585.00
1130-AM2	(Including Type 1130-P2 Time-Base Oscillator/ Multiplier) <b>Bench Mount</b> .....	LAPEL	2750.00
1130-AR2	(Including Type 1130-P2 Time-Base Oscillator/ Multiplier) <b>Rack Mount</b> .....	MOCHA	2750.00
1130-AM3	(Including Type 1130-P3 Time-Base Oscillator) <b>Bench Mount</b> .....	LASSO	2670.00
1130-AR3	(Including Type 1130-P3 Time-Base Oscillator) <b>Rack Mount</b> .....	MOGUL	2670.00
1130-AM4	(Including Type 1130-P4 Precision Time-Base Os- cillator) <b>Bench Mount</b> .....	LUNER	2950.00
1130-AR4	(Including Type 1130-P4 Precision Time-Base Os- cillator) <b>Rack Mount</b> .....	METAL	2950.00

PATENT NOTICE. See notes 4 and 8, page viii; also U. S. Patent 2,977,540.

## TYPE 1132-A DATA PRINTER

The TYPE 1132-A Data Printer is a Clary\* TYPE 1961 Scanning Printer especially modified to operate with 1-2-4-2 BCD codes and voltage levels of the TYPE 1130-A Digital Time and Frequency Meter. This machine has 12-column register capacity. A cable is supplied to connect it with the TYPE 1130-A to print all 8 digits displayed. The other four columns are on the right hand side of the 8 printed columns from the TYPE 1130 and can be used to display additional data such as the time from a digital clock. These four columns are decimal entry, requiring a single-pole 10-position switch per column. Data can also be entered in any column from the manual keyboard on the instrument. A full range of complementary equipment is available from the



Clary Corporation to adapt the TYPE 1132-A to other data-handling systems and media. Prices and system descriptions for this auxiliary equipment may be had by writing to either the General Radio Company or the Clary Corporation, San Gabriel, California.

### SPECIFICATIONS

**Input Signals:** 1-2-4-2 BCD 8 digits. Logical 0, 165 v min, logical 1, 90 v max.

**Print Command Pulse:** Negative, over 20 volts; duration 10  $\mu$ sec or more.

**Maximum Printing Rate:** 3 lines/sec. A continuously variable print-command holdoff circuit is provided to reduce the number of prints from maximum to approxi-

mately 1 print in 10 sec, irrespective of counting rate.

**Power Supply:** 105 to 125 volts, 50 to 60 cps, 100 watts.

**Dimensions:** Width 19 3/4, height 8 3/4, depth 20 inches (505 by 225 by 510 mm), over-all.

**Net Weight:** 60 pounds (27.2 kg).

**Accessories:** Cable to connect to TYPE 1130-A.

TYPE		CODE WORD	PRICE
1132-A	<b>Data Printer</b> .....	LILAC	\$1450.00

\*Manufactured and serviced by the Clary Corporation of San Gabriel, California.





## TYPE 1130-P TIME-BASE PLUG-IN UNITS

Four time-base units are available for use with the TYPE 1130-A Digital Time and Frequency Meter. Each of the combinations listed on the preceding page includes one such unit.

In addition, these plug-in units are available separately for those who wish to use more than one type of time base. All can be used with 5-Mc external drive.

### TYPE 1130-P4 PRECISION TIME-BASE OSCILLATOR

This unit contains an accurate and stable crystal oscillator, but can also be used to couple to an external 5-Mc standard-frequency oscillator.

**External Drive Requirements:** 5 Mc; 1 volt rms into 50 ohms.

**Internal Oscillator:** A vacuum-sealed 5-Mc crystal and solid-state circuit in a constant-temperature, proportional-control oven. Operates directly from the power line connection of the TYPE 1130-A Digital Time and Frequency Meter.

**Long-Term Drift:** Less than  $5 \times 10^{-6}$  per day after 60 days of operation.

**Typical Drift:** Less than  $1 \times 10^{-9}$  per day after one year of operation.

**Short-Term Stability:** Less than  $1 \times 10^{-3}$  per minute (one-second sampling time).

**Temperature Coefficient:** Less than  $3 \times 10^{-10}$  per degree C from 0 to 50 C.

**Line-Voltage Effects:** Less than  $2 \times 10^{-10}$  for  $\pm 15\%$  voltage change.

**Power Input:** 7 watts.



Type 1130-P4



Type 1130-P3



Type 1130-P2



Type 1130-P1

### TYPE 1130-P3 TIME-BASE OSCILLATOR

For use with external 5-Mc standard-frequency oscillator or with internal crystal oscillator. External drive requirements are the same as for Type 1130-P4, above.

**Internal Oscillator:** 5-Mc crystal oscillator operating at room temperature.

**Stability:**

**Long-Term Drift:** Less than  $10 \times 10^{-6}$  in 6 months.

**Short Term:** Less than  $2 \times 10^{-7}$  per week  
Less than  $1 \times 10^{-8}$  per minute

**Temperature Coefficient:** Less than  $2 \times 10^{-7}$  per degree Centigrade.

**Tube Complement:** One 6U8.

### TYPE 1130-P2 TIME-BASE OSCILLATOR/MULTIPLIER

This unit can be used with external frequency input of 5 Mc, 1 Mc, or 100 kc.

**External Drive Requirements:**

- 5 Mc — 1 volt rms into 50 ohms
- 1 Mc — 2 volts rms into 1 kilohm
- 100 kc — 1 volt rms into 100 kilohms.

**Internal Oscillator:** Same as in TYPE 1130-P3, above.

**Tube Complement:** Two 6X8; one each 5965, 6U8.

### TYPE 1130-P1 COUPLING UNIT

For use with external 5-Mc oscillator only. Input requirements are 1 volt rms into 50 ohms. This unit provides an inexpensive means of using a highly stable oscillator, such as the TYPE 1113-A, page 70, as a time base for the counter.

TYPE		CODE WORD	PRICE
1130-P4	Precision Time-Base Oscillator . . . . .	MUGGY	\$400.00
1130-P3	Time-Base Oscillator . . . . .	MONAD	120.00
1130-P2	Time-Base Oscillator/Multiplier . . . . .	MERRY	200.00
1130-P1	Coupling Unit . . . . .	MERCY	35.00
1130-P5	Servicing Accessory* . . . . .	MOLAR	30.00

\* Permits operation of any one of the 11 decade counter boards clear of the instrument for operational trouble shooting. PATENT NOTICE. See Note 4, page viii.

# FREQUENCY CONVERTER



## TYPE 1134-A DIGITAL-TO-ANALOG CONVERTER

**USES:** The TYPE 1134-A Digital-to-Analog Converter provides accurate analog output from digital input. It is designed for use with the TYPE 1130-A Digital Time and Frequency Meter and the TYPE 1131-P4 Storage Decade; BCD input with either 1-2-4-2 or 1-2-2-4 weighting is accepted. It may be used in connection with other digital equipment if the correct coding and the correct voltage levels are provided (see Specifications). It is fully electronic in operation; the response speed is not limited by mechanically moving parts. The rise and fall times of the analog output are less than 1 msec. A choice of 1 ma or 100 mv permits the use of galvanometer- or potentiometer-type recorders.

**DESCRIPTION:** The input signals consist of 3 digits (4 lines each). They operate transistor

switches which connect weighting resistors ( $R_1$ - $R_4$  in the diagram) either to ground or a stable voltage  $E$ . The 1-ma output is essentially a 30-v swing behind 30-k $\Omega$  source impedance. 100-mv output is obtained by connecting a 100- $\Omega$  resistor across output.

Full-scale output can be adjusted to compensate for recorder impedance. Critical components are housed in a constant-temperature oven for  $\pm 0.1\%$  over-all stability and accuracy.

### FEATURES:

- > Analog recording from digital data without the use of mechanical switches.
- > High over-all accuracy and stability of .1% utilize the full capabilities of precision analog recorders.
- > 1 ma or 100 mv output.

### SPECIFICATIONS

**Data Input:** BCD, weighted 1-2-4-2 or 1-2-2-4. Binary "1" +90 v max. Binary "0" +150 v min. Source imped-

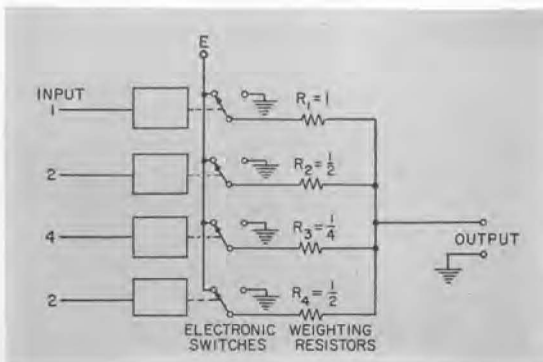

One decade of 1134-A. All switches are shown in binary state "1".

ance 500 k $\Omega$  max. Input Impedance 1 M $\Omega$ . Can be driven from General Radio TYPE 1130-A Digital Time and Frequency Meter or TYPE 1131-P4 Storage Units. Digit selector switch selects any adjacent 3, or the last 2, of 4-decade input.

**Output:** 1 ma with 30-kc source impedance or 100 mv across 100 $\Omega$ . Positive side grounded.

**Load:** 2000 ohms maximum for 1 ma. 2000 ohms minimum, for 100 mv.

**Linearity:**  $\pm 0.05\%$  of full scale.

**Stability:**  $\pm 0.02\%$  for  $\pm 15\%$  line.  $\pm 0.03\%$  for ambient from 0-50 C.

**Warm-Up Drift:** Less than .5% of full scale. Thermal equilibrium after 30 minutes.

**Power:** 100 to 130 (or 200 to 260) volts, 50 to 60 cps 30 watts maximum.

**Accessories Supplied:** Power cord, spare fuses, cable to connect to TYPE 1130-A.

**Transistor Complement:** One 2N1374, two each 2N1184, 2N1377, fourteen 2N520A, and twelve 2N1373.

**Dimensions:** Width 19, height 3 $\frac{1}{2}$ , depth 13 $\frac{1}{2}$  inches (483 by 86 by 343 mm), over-all.

**Net Weight:** 16 $\frac{1}{4}$  pounds (7.4 kg).

TYPE		CODE WORD	PRICE
1134-AM	Digital-To-Analog Converter (Bench Mount) . . .	MOTTO	\$595.00
1134-AR	Digital-To-Analog Converter (Rack Mount) . . .	MINOR	595.00





## TYPE 1131 COUNTING DECADES

TYPE 1131 Counting Decades are plug-in components of the TYPE 1130 Digital Time and Frequency Meter. They are offered primarily as replacement units for the Frequency Meter, but are also useful as components in special digital systems. They are of particular interest because they make available for the first time, a system of decimal counting units, with resolution up to 1 Mc, which can be used to construct a counting register capable of being read into a parallel storage register. Any of the counting decades 1131-P1 through 1131-P3 can be caused by the 1131-P5 transfer unit to pass its data into 1131-P4 Storage Units. A technical monograph describing the system is available upon request. When a complete transfer-to-storage system is to be constructed please write for further technical details. All units plug into a standard 20-pin Elco Connector, Elco Number PCV-2-20-A2 $\frac{3}{4}$ .

### FEATURES:

- Highly reliable units.
- Improved feedback code.
- Do not require regulated power supplies.
- Not critical with respect to pulse input requirements.
- 1-2-4-2 BCD outputs for TYPE 1132-A Data Printer or TYPE 1134-A Digital-to-Analog Converter.

### TYPE 1131-P3

This is a decimal counting unit having 1.1-Mc resolution, 1-2-4-2 BCD outputs from both plates of each flip-flop and a columnar neon lamp display. The binary outputs from one set of flip-flop plates will drive 1131-P4 counting-storage combination units.

**Maximum Counting Frequency:** 1.15 Mc.

**Power Input:** Heater, 6.3 v  $\pm 5\%$ , 3.1 amp. Plate 225 v, 46 ma.

**Input Signals:** 0.5- $\mu$ sec pulse, 8 v min to 20 v max.

Reset to 0 with 70-v, 100- $\mu$ sec pulse.

Set to 9 by opening reset lead.

**Output Signals:** Carry pulse, de-coupled from buffer to TYPE 1131-P2, typically 60 v in 13 kilohms.

Binary Outputs: 1-2-4-2 BCD.

1 = 65 v, nominal; 0 = 185 v, nominal.

Output Impedance, 0.5 megohm

Max. load current, 50  $\mu$ a.

To drive TYPE 1131-P4 Storage Decade,

1 = 185 v; 0 = 65 v.

### TYPE 1131-P2

A decimal counting unit of over 100 kc resolution. It is designed to operate from the output of the TYPE 1131-P3 and to feed data to the TYPE 1131-P4 Counting-Storage Units.

**Maximum Counting Frequency:** 115 kc.

**Power Input:** 6.3 v  $\pm 5\%$ , 2 amp; 300 v, 20 ma.

**Input Signals:** Carry output of TYPE 1131-P3, negative step, 60v nominal.

Reset and Set 9: same as TYPE 1131-P3.

**Output Signals:** Carry output, 120 v negative step at count of 10.

Binary Output: Same as TYPE 1131-P3.

### TYPE 1131-P1

A decimal counting unit with resolution of 30 kc. It is the most economical unit and may be used repetitively in lower speed counting systems.

**Maximum Counting Frequency:** 30 kc.

**Power Input:** 6.3 v  $\pm 5\%$ , 1.2 amp; 300 v, 12 ma.

**Input Signals:** Carry input, negative step, 120 v nominal; typical range, 75-200 volts. Reset and set 9: same as TYPE 1131-P3.

**Output Signals:** Both carry and binary.

Same as TYPE 1131-P3.

### TYPE 1131-P4

A combination unit for either counting or storage. As a decimal counting unit it operates in the same fashion as TYPE 1131-P1. Used with the TYPE 1131-P5 Transfer Unit, an 1131-P4 can store data counted by any of the decades above.

**Maximum Counting Frequency:** 25 kc.

**Input Power:** 6.3 v  $\pm 5\%$ , 1.3 amp; 300 v, 12 ma.

**Input signals:** Same as TYPE 1131-P1.

**Output Signals:** Carry, same as TYPE 1131-P3.

### TYPE 1131-P5

The TYPE 1131-P5 unit is necessary to produce the signals required for reading data from the TYPE 1131-P3 through TYPE 1131-P1 counting units into the TYPE 1131-P4 storage units. One TYPE 1131-P5 unit is adequate to operate an eight-digit transfer register. (8 TYPE 1131-P1's to 8 TYPE 1131-P4's for example.)

**Power Input:** 6.3 v  $\pm 5\%$ , 1.5 amp; 300 v nominal, 18 ma.

**Transfer Command:** Negative 120-volt step (1 ma into 120 kilohms).

**Maximum Transfer Rate:** 500 per sec, approximately.

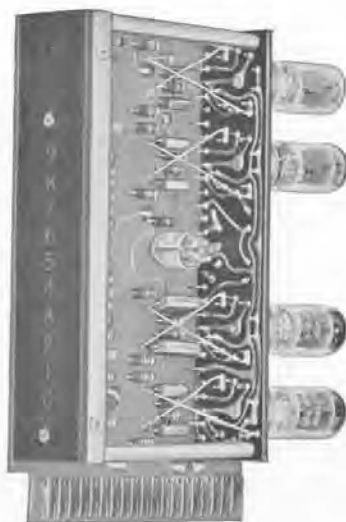

TYPE		CODE WORD	PRICE
1131-P1	Counting Decade	UNION	\$ 70.00
1131-P2	Counting Decade	UNDER	78.00
1131-P3	Counting Decade	UDDER	145.00
1131-P4	Counting-Storage Decade	ULCER	80.00
1131-P5	Transfer Decade	UMBER	62.00

PATENT NOTICE. See Note 8, page viii; also U. S. Patent 2,977,540.





### TYPE 1213-D UNIT TIME/FREQUENCY CALIBRATOR



**USES:** The TYPE 1213-D Time/Frequency Calibrator is a compact secondary standard of frequency containing in a single package the circuits necessary for calibration operations that have hitherto required several instruments. These circuits include: (1) a crystal-controlled source of harmonics at multiples of 10 Mc, 1 Mc, 100 kc, and 10 kc, (2) mixer and beat amplifier, and (3) a pulse amplifier.

The self-contained mixer and audio amplifier permit calibration of oscillators and signal generators without requiring any additional equipment. The standard-frequency harmonics are useful for receiver calibration and for frequency measurement with external detectors and interpolating equipment.

With auxiliary Unit Oscillators for interpolation and an oscilloscope for zero-beat indications, this calibrator can measure accurately all the frequencies of radio broadcast and television transmitters.\*

The output signals from the cathode-follower pulse amplifier can be used on oscilloscopic time calibration or pulse trigger applications. The output can be differentiated in the TYPE 1213-P1 Differentiator to provide pulses at intervals of 0.1  $\mu$ sec, 1.0  $\mu$ sec, 10  $\mu$ sec and 100  $\mu$ sec for time markers in swept-frequency applications and for calibrating variable time-delay units and oscilloscopes. The amplitude of the pulses is sufficient to trigger pulse-generating equipment and oscilloscope sweeps.

The crystal oscillator can be standardized with standard-frequency radio transmissions.

\* Described in *Technical Publication B10*; copy free on request.

**DESCRIPTION:** The crystal oscillator uses a 5-Mc AT-cut, hermetically sealed quartz plate of exceptionally small temperature coefficient at room temperatures and is electron-coupled to a 2:1 multiplier, followed by a buffer stage. The 10-Mc buffer drives a series of multi-vibrators with fundamentals of 1 Mc, 100 kc, and 10 kc. Their outputs can be switched to drive either a harmonic generator or video amplifier. The harmonic generator feeds a crystal mixer, and coaxial output connector. For harmonic calibration with the mixer, the video amplifier is switched to act as a high-gain audio amplifier at the mixer output. For oscilloscopic time calibration, the video amplifier supplies pulses at binding-post terminals.

A narrow-range frequency adjustment ( $\pm 5$  ppm) is provided for setting the crystal oscillator to zero beat with standard-frequency radio transmissions or other external standards. A touch-button deviator is provided to introduce a small frequency decrease for establishing "sense" in indications near zero beat.

#### FEATURES:

- High accuracy — a few parts in  $10^7$ .
- Wide range of output frequencies.
- Easily adjusted to zero beat with WWV standard-frequency transmissions.
- Accurate timing source for oscilloscopes.
- Compact unit construction.
- Internal mixer for maximum utility.

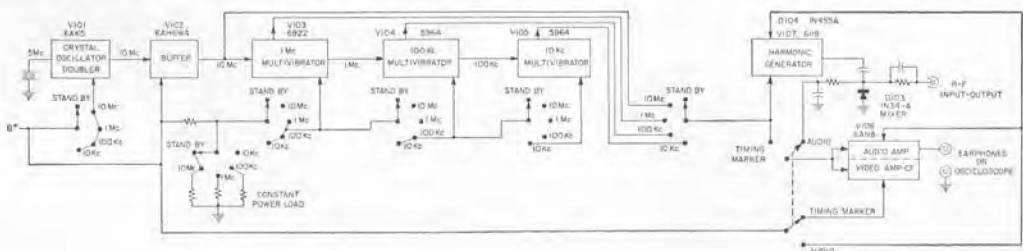



### SPECIFICATIONS

**Output Frequencies:** 10 Mc, 1 Mc, 100 kc, 10 kc.  
**Output Amplitude:** 10 Mc: 5 v peak-to-peak; 30 v peak-to-peak at lower output frequencies from pulse amplifier; rf harmonics usable to 1000 Mc from 10-Mc output, to 500 Mc from 1-Mc output, to 100 Mc from 100-ke output, and to 10 Mc from 10-ke output.  
**Output Impedance:** Video cathode-follower, 300 ohms; rf output obtained from crystal-diode harmonic generator.

#### Frequency Stability:

##### 1. Temperature

##### a. Warm-up Characteristics:

For ambient temperatures of 25C, or over, the warm-up drift will not exceed  $-2 \times 10^{-7}/C$ . With ambient 0–10C crystal may not operate until instrument attains operating temperature. Minimum operating ambient 0C.

##### b. Operating Characteristics:

In ambient range 20–40C, the oscillator drift is between  $-1 \times 10^{-7}/C$  and  $+2 \times 10^{-7}/C$ .

##### 2. Line-Voltage Effects

Momentary line voltage changes of  $\pm 10\%$  affect

frequency by less than  $5 \times 10^{-8}$ . Changing line voltage will affect frequency per temperature specification above ( $\pm 10\%$  line will change temperature  $\pm 4C$ ).

##### 3. Switching and Loading Effects

The combined effects of switching and loading due to external connections are less than  $1 \times 10^{-7}$ .

**Sensitivity:** Usable beat notes can be produced with 50 millivolts signal input to mixer over the harmonic ranges specified above under "Output Amplitude."

**Tube Complement:** One each 6AK6, 6AH6WA, 6922, 6AN8, 6U8; two 5964.

**Power Required:** 6.3 v ac, 3 amp; 300 v dc, 60 ma. TYPE 1203-B Unit Power Supply is recommended.

**Accessories Supplied:** TYPE 1213-P1 Differentiator, TYPE 874 Coaxial Connector, and multipoint connector.

**Mounting:** Aluminum panel and sides finished in gray; aluminum cover finished in clear lacquer. Relay-rack panel (TYPE 480-P4U3) is available for mounting both calibrator and power supply.

**Dimensions:** Width  $10\frac{1}{2}$ , height  $5\frac{3}{4}$ , depth 7 inches (270 by 150 by 180 mm), over-all.

**Weight:**  $4\frac{3}{4}$  pounds (2.2 kg).

TYPE		CODE WORD	PRICE
1213-D*	Unit Time/Frequency Calibrator .....	REBEL	\$310.00
1203-B	Unit Power Supply .....	ALIVE	50.00
480-P4U3	Relay-Rack panel (7 inch) for mounting both calibrator and power supply .....	UNIPANCART	12.00

\*PATENT NOTICE. See Note 4, page viii.

For a detailed description of the Calibrator, see R. W. Frank and H. P. Stratmeyer, "A Time/Frequency Calibrator of Improved Stability" *General Radio Experimenter*, 30, 10, October, 1959.



## TYPE 1142-A FREQUENCY METER AND DISCRIMINATOR

This new analog-type frequency meter sets a new high in range, sensitivity, convenience, and accuracy.

It will measure directly frequencies from 3 cps to 1.5 Mc with an over-all accuracy of  $\pm 0.2\%$ , and can be used with a recorder to produce time records of frequency change or drift.

Its highly linear discriminator, with an external voltmeter, can measure fm deviation. With a wave analyzer, incidental fm in oscillators and amplifiers can be measured.

The usable frequency range, particularly for frequency-drift and incidental-fm measure-

ments, can be extended upward to thousands of megacycles if the frequency to be measured is heterodyned with a known standard. This gives a proportionate increase in resolution, permitting measurements of both frequency drift and incidental fm to at least one part in  $10^9$ .

**DESCRIPTION:** A pulse-count type of discriminator is used in this frequency meter. The input signal is clipped and amplified by the input stages. The resulting rectangular pulses trigger a Schmitt circuit, which, in turn, triggers a monostable multivibrator to produce a pulse

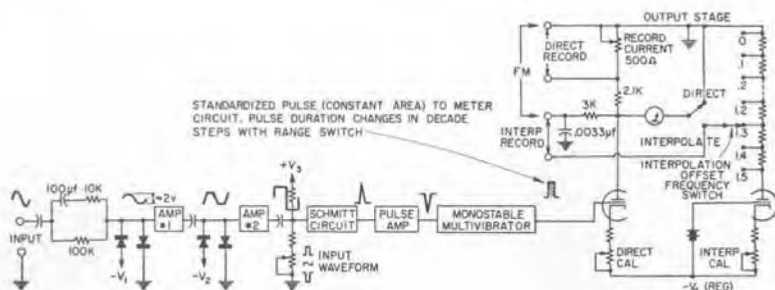

of constant amplitude and duration for each input pulse.

The average dc component of this train of pulses actuates the meter. For a constant-frequency input, these pulses are equally spaced in time. When frequency modulation is present, the time spacing varies, and the resulting additional ac component is a faithful reproduction of the modulating frequency; its amplitude is a measure of the modulation deviation.

The precision 6-inch meter is accurate to 1% of indication down to 10% of full-scale.

A calibrated interpolation technique expands any one of 15 equal portions of the meter scale to cover two-thirds of the scale; this results in a readout accuracy of 0.1%.

Output is available for driving conventional 1-ma and 5-ma recorders. An interpolation output is provided for recording when higher resolution is desired.

Controls are simple and well marked; operation is straightforward and convenient.

The instrument is housed in a rack-bench cabinet (see page 242) and is normally supplied for bench use. Panel extensions are available for relay-rack mounting.

### FEATURES:

- Wide frequency range
- High sensitivity
- High accuracy
- Recorder output
- Precision components throughout

### SPECIFICATIONS

**Range:** 3 cps to 1.5 Mc in five decade ranges. Full-scale values are 150 cps, 1.5 kc, 15 kc, 150 kc, and 1.5 Mc. A calibrated interpolation feature effectively expands the meter scale by a factor of ten, so that 1/10 of any of the above ranges covers the full meter scale.

#### Accuracy:

**Recorder Output Current:** 0.05% of full scale  $\pm$  0.05% of reading, below 15 kc. 0.1% of full scale  $\pm$  0.1% of reading, above 15 kc.

**Meter Error: Direct Reading,** 1% of reading above 10% of full scale (0.1% of full scale below 10% of full scale). **Interpolating,** 0.1% of full scale (range switch setting).

**Line Voltage:**  $\pm$  10% change produces approximately  $\pm$  0.15% change in reading below 150 kc;  $\pm$  1% above 150 kc.

**Warm-Up Drift:** Less than 0.2% of reading, after a few minutes, substantially complete within 30 minutes.

**Ambient Temperature:** Output current changes less than 100 ppm/ $^{\circ}$ C below 150 kc, less than 400 ppm/ $^{\circ}$ C above 150 kc.

Over-all accuracy is the sum of the recorder output current error, and any of the above applicable errors. **Calibration:** Internal calibration at twice line frequency to standardize output current.

**Sensitivity:** 20 mv, rms, for frequencies between 20 cps and 150 kc, rising to 200 mv at 3 cps and 1.5 Mc. Peak-to-peak voltage requirements for pulse and sine-wave inputs are approximately equal, except for extremely short pulses. Input pulse widths of the order of a nano-second may require as much as 5 volts.

**Maximum Input Voltage:** 300 volts peak, 100 volts peak above 150 kc.

**Input Impedance:** 100,000 ohms, dropping to a minimum of 10,000 ohms above 150 kc.

#### Discriminator Characteristics:

**Output Voltage:** 15 volts dc, full-scale (1.5) on all ranges.

**Residual FM Noise:** More than 100 db below full output (primarily 60 and 120 cps) (with 400 cps power, noise is 90 db down). Measured with the TYPE 736-A Wave Analyzer, residual noise at other frequencies is more than 120 db down from full output.

**Linearity:** 0.05% of full scale (15 v)  $\pm$  0.05% of output voltage, below 15 kc; 0.1% of full scale (15 v)  $\pm$  0.1% of output voltage, above 15 kc.

#### Recorder Output:

**Direct:** Output current adjustable to drive recorders from 1 ma (2700 ohms, max) to 5 ma (190 ohms, max).

**Interpolate:** Full scale, 0.64 volt behind 4800 ohms.

**Tubes:** One 6AW8, one 5687, one 6AN5, three 5965, one 6AV5GA, one 5651.

**Accessories Supplied:** TYPE CAP-22 Power Cord, spare fuses.

**Power Supply:** 105 to 125 (or 210 to 250) volts, 50-60 and 400 cps, 85 watts.

**Dimensions:** Width 12, height 5  $\frac{3}{8}$ , depth 12 inches (305 by 149 by 305 mm); panel, 12 by 5  $\frac{1}{4}$  inches (305 x 135 mm).

**Net Weight:** 16 pounds (7.3 kg).

TYPE	CODE WORD	PRICE
1142-A*	MAGIC	\$495.00
480-P312	MERIT	6.50 Pair
Frequency Meter and Discriminator Panel Extensions for Relay Rack		

\* PATENT NOTICE. See notes 15 and 16, page viii.

For complete description, see *General Radio Experimenter*, Volume 35, No. 1 January, 1961.

# STANDARD-SIGNAL GENERATORS



A standard-signal generator is a source of alternating-current energy of accurately known characteristics. The carrier or center frequency is indicated by a dial setting, the output voltage by a meter reading and associated attenuator setting, and the modulation by a meter reading set by appropriate control knobs. Common types of modulation signals are sine-wave, square-wave and pulse; the output signal may be either frequency- or amplitude-modulated by these signals. When the fm modulating system produces a considerable excursion in frequency at a relatively low cyclical rate, the instrument is known as a sweep generator and is particularly useful for automatic data display. Standard-signal generators are used for testing radio receivers, as voltage standards over the range from a few microvolts to about a volt, and generally as power sources in the measurement of gain, bandwidth, signal-to-noise ratio, standing-wave ratio, and other circuit properties.

The elements of a standard-signal generator are shown in Figure 1. A buffer amplifier is sometimes added to reduce incidental frequency modulation. The requirements for the oscillator are that it be stable, that it have reasonably constant output over any one frequency range, that the waveform be good, and that hum and noise modulation be negligible. Over-all shielding of the generator is also necessary to minimize stray fields.

General Radio standard-signal generators are well-shielded, general-purpose instruments, which cover frequencies from 5 kilocycles per second to 910 megacycles per second, a frequency span of 181,000:1.

Internal amplitude (sine-wave) modulation is provided at one or more fixed frequencies. Various types of external modulation can also be applied.

(1) Provision is made for modulation over the entire audio-frequency range from an external source.

(2) Amplitude modulation in signal generation is generally accompanied by some incidental frequency modulation. This can be substantially eliminated, at low cost, by the use of external crystal-diode absorption modulators, which also make possible modulation at video frequencies and high-quality pulse modulation.

The TYPE 1000-P6 Crystal Diode Modulator consists of a crystal diode connected between the input and output terminals with means for applying bias and modulating voltages to the crystal. It can be used at carrier frequencies between 20 and 1000 megacycles and can produce up to 30% amplitude modulation from 0 to 5 megacycles. The maximum output of the TYPE 1000-P6 Crystal Diode Modulator is approximately 10 millivolts.

The TYPE 1000-P7 Balanced Modulator is similar but suppresses carrier leakage to a considerably greater extent. It consists of two crystal diodes, a tunable section of coaxial line between input and output terminals, and associated circuits for applying bias and modulating voltages. It is designed for use at carrier frequencies from 60 to 2300 megacycles and can produce linear 100% amplitude modulation and pulse modulation with fast rise time and with a high on-off ratio.

(3) For sweeping, the TYPE 1750-A Sweep Drive is recommended. This mechanical device is used to sweep carrier frequency back and forth over a narrow range, in order to plot or to display the amplitude-vs-frequency characteristics of components and networks. The shaft of the sweep drive is connected by a flexible coupling to the shaft of the frequency-determining element in the radio-frequency oscillator as indicated schematically in Figure 2. Reciprocating rotation up to 300 degrees can be imparted at rates of 1 to 5 cycles per second. The corresponding percentage variation in frequency is listed for each one of the General Radio Signal Generators.

## STANDARD-SIGNAL GENERATORS

TYPE	FREQUENCY RANGE	OPEN-CIRCUIT VOLTAGE	OUTPUT IMPEDANCE	MODULATION %	PAGE
1001-A	5 kc-50 Mc	0.1 $\mu$ v-200 mv	10 $\Omega$ , 50 $\Omega$	0-80%	86
805-C	16 kc-50 Mc	0.2 $\mu$ v-4 v	0.75, 7.1, 37.5, 50 $\Omega$	0-100%	88
1021-AV	40-250 Mc	0.5 $\mu$ v-1 v	50 $\Omega$	0-50%	90
1021-AU	250-940 Mc	0.5 $\mu$ v-1 v	50 $\Omega$	0-50%	90

## MODULATORS

TYPE	CARRIER RANGE	MODULATION FREQUENCY RANGE	MODULATION %	PAGE
1000-P6	20-1000 Mc	0-5 Mc	0-30%	92
1000-P7	60-2300 Mc	0-20 Mc	0-100%	93

## ACCESSORIES

TYPE		PAGE
1000-P3	100:1 Voltage Divider	92
1000-P4	Dummy Antenna	92
1000-P5	VHF Transformer (50 ohms grounded to 300 ohms balanced)	92
1000-P10	Test Loop	92

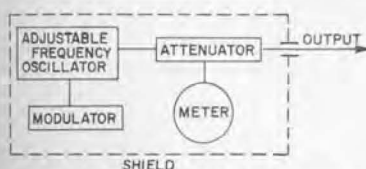

Figure 1. Elements of a standard-signal generator.

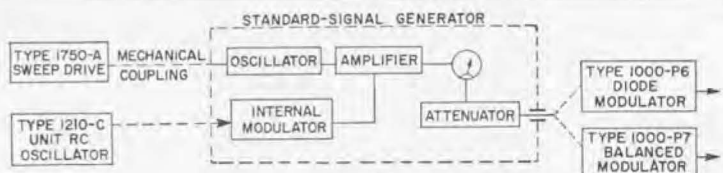
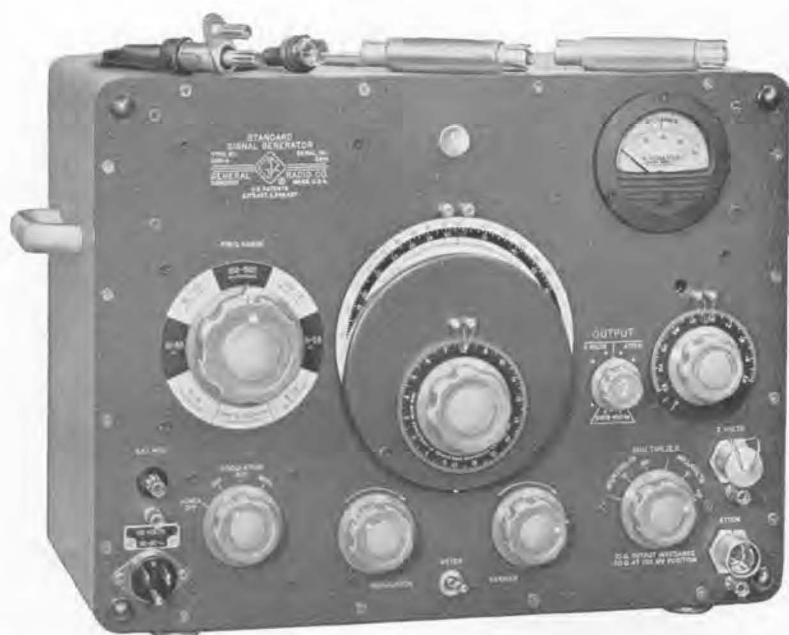

Figure 2. Modulation methods.



### TYPE 1001-A STANDARD-SIGNAL GENERATOR

**USES:** The TYPE 1001-A Standard-Signal Generator is a laboratory instrument for use in determining the performance of receivers and other equipment at ultrasonic and radio frequencies. Its sturdy construction and simplicity of operation make it suitable for production testing. Because of its small size, light weight, and low power consumption, it can be adapted for use in field-strength measurements.

With the TYPE 1000-P6 Crystal Diode Modulator, the generator output can be modulated at video frequencies for testing television i-f circuits.

The frequency can be swept over a maximum range of 14% by the TYPE 1750-A Sweep Drive, which attaches to the slow-motion dial.

**DESCRIPTION:** The welded aluminum cabinet of the TYPE 1001-A Standard-Signal Generator houses three separate groups of circuits. The power supply is at the top, the completely shielded radio-frequency portion in the middle, and the modulation and control circuits at the bottom.

The Hartley-type carrier-frequency oscillator covers the frequency spectrum from 5 kc to 50 Mc in eight ranges. The plates of the main tuning capacitor are shaped to give a logarithmic variation of frequency with angular rotation. The precision of frequency setting, therefore, is constant, and the vernier dial is

calibrated directly in percentage frequency increments.

A buffer amplifier is used between the oscillator and the low-impedance output circuits. The amplifier is grid modulated to provide amplitude modulation from 0 to 80 percent. Loose coupling between the oscillator and the amplifier minimizes incidental frequency modulation. The attenuator system and the output meter are coupled to the amplifier through a high-pass filter, which reduces voltages of the modulation frequency in the output.

The output voltage is determined by establishment of a fixed carrier level at the attenuator input and by the setting of two attenuator controls. The carrier level is set by adjustment of the plate-supply voltage of the oscillator and is indicated by a vacuum-tube voltmeter at the attenuator input. The attenuator system consists of a continuously adjustable L network controlled by the output dial and a decade ladder-network attenuator.

The modulation circuits include a 400-cycle RC oscillator for internal modulation and a germanium-crystal rectifier to determine modulation percentage. Percentage modulation is read on the same panel meter that indicates the carrier output level.

#### FEATURES:

> Output cable termination can be removed for matching into a 50-ohm system.





- Very low residual output and stray field.
- A periodic output amplifier avoids sideband clipping and minimizes reaction of attenuator setting or load on carrier frequency.
- Excellent stability and low drift are assured

by high-quality components, low power consumption, and stabilized power supply.

- Simplicity of design and construction has resulted in an unusually sturdy instrument of small size, low weight, and long life.

### SPECIFICATIONS

#### Carrier Frequency

**Range:** 5 kc to 50 Mc covered in eight direct-reading ranges: 5 to 15 kc, 15 to 50 kc, 50 to 150 kc, 150 to 500 kc, 0.5 to 1.5 Mc, 1.5 to 5 Mc, 5 to 15 Mc, and 15 to 50 Mc.

**Scale:** Logarithmic up to 15 Mc, departing slightly from the logarithmic scale at higher frequencies.

**Vernier Dial:** Frequency increment is 0.1% per dial division at frequencies up to 15 Mc.

**Accuracy:**  $\pm 1\%$ .

**Stability:** Warm-up drift is of the order of 0.25%. Half the maximum drift is reached in approximately  $1\frac{1}{2}$  hours.

**Sweeping:** Maximum sweep range with the TYPE 1750-A Sweep Drive is 14%.

#### Output

**Voltage Range:** Open-circuit output voltage at the attenuator jack is continuously adjustable from 0.1 microvolt to 200 millivolts. With output cable terminated at both ends, output voltage is continuously adjustable from 0.05 microvolt to 100 millivolts. Open-circuit output voltage at the 2 VOLTS panel jack is measured directly by the output meter and is 2 volts if the meter is set to the reference mark. This voltage is available up to at least 15 Mc.

**Voltage Accuracy:** At frequencies below 10 Mc, when the output dial is set near full scale or one-tenth full scale, the output voltage is correctly indicated to  $\pm (6\% + 0.1 \mu\text{v})$ . With the output dial set in the mid-scale region, the error may be greater by 4%. At frequencies above 10 Mc, when the output dial is set near full scale, the output voltage is correctly indicated to an accuracy of  $\pm (10\% + 0.3 \mu\text{v})$  and the error may be as much as 10% larger or smaller at other output dial settings.

The accuracy of the open-circuit output voltages at the 2 VOLTS panel jack is  $\pm 3\%$  up to 15 Mc.

**Impedance:** Output impedance at the attenuator jack is 10 ohms (50 ohms when the series unit is used) except for the highest output position of the attenuator, where it is 50 ohms.

Output impedance at the end of the terminated cable is 25 ohms. Output impedance at the 2 VOLTS panel jack is 300 ohms.

An output impedance of one ohm (with output voltage reduced 100:1) can be obtained with the TYPE 1000-P3 Voltage Divider.

Use of the TYPE 1000-P4 Dummy Antenna provides a standard (IRE) test impedance. A known induction field is obtainable with the TYPE 1000-P10 Test Loop (for testing loop receivers).

**Amplitude Modulation:** Adjustable from zero to 80%. Modulation percentage is indicated on the panel meter and is accurate within  $\pm 10\%$  of the indicated value, with a possible additional error of 2% modulation.

The internal modulation frequency is 400 cps  $\pm 5\%$ .

The external modulation characteristic is flat within

$\pm 1$  decibel from 20 cps to 15 kc. To provide 80% modulation, the external audio oscillator must supply 12 volts into a 4000-ohm load (36 milliwatts).

**Incidental Frequency Modulation:** At 80% amplitude modulation, the incidental frequency modulation varies from 30 to 300 parts per million over each carrier-frequency range except for the highest range (15 to 50 Mc) where it may be three times as great. At lower modulation percentages, frequency modulation is approximately proportional to modulation percentage.

For applications above 20 Mc, where incidental frequency modulation must be very low, the use of the TYPE 1000-P6 Crystal Diode Modulator (page 92) is recommended.

#### Distortion and Noise Level

**Envelope Distortion:** Less than 8% at 80% amplitude modulation.

**Carrier Noise Level:** Corresponds to about 0.1% modulation.

**Carrier Distortion:** Of the order of 7% on all except the lowest range, where it may increase to approximately 15%.

**Leakage:** Stray fields at 1 Mc are less than one microvolt per meter two feet from the generator.

#### Tube Complement:

1 — 6C4      1 — 6AL5      2 — 0C3  
1 — 6L6      1 — 5Y3-GT      1 — 6SN7-GT

**Terminals:** TYPE 874 Coaxial Terminals are provided for the attenuator output and for the constant 2-volt output.

**Power Input:** 105 to 125 (or 210 to 250) volts, 40 to 60 cps. Power input is approximately 65 watts. A three-wire cord is supplied.

This instrument will also operate satisfactorily on power supply frequencies up to 400 cps, provided that the supply voltage is at least 115 volts.

**Accessories Supplied:** TYPE 874-R22 3-foot Coaxial Cable, TYPE 1000-P1 50-Ohm Termination Unit, TYPE 1000-P2 40-Ohm Series Unit, TYPE 874-Q2 Adaptor, TYPE TO-44 Adjustment Tool (stored in cabinet), TYPE 274-MB Plug, TYPE 874-C58 Cable Connector, TYPE 874-PB58 Panel Connector, spare fuses, and a TYPE CAP-22 Power Cord.

**Other Accessories Available:** Not supplied but available on order are the TYPE 1000-P3 Voltage Divider, the TYPE 1000-P4 Standard Dummy Antenna, the TYPE 1000-P10 Test Loop, the TYPE 1000-P6 Crystal Diode Modulator (pages 92 and 93), and the TYPE 1750-A Sweep Drive (page 144).

**Mounting:** The instrument is assembled on an aluminum panel, finished in gray crackle lacquer. The aluminum cabinet has a wrinkle finish and has carrying handles. A recessed compartment is built into the top of the cabinet for storing accessories.

**Dimensions:** Width  $20\frac{1}{4}$ , height  $13\frac{3}{4}$ , depth 11 inches (515 by 350 by 280 mm) over-all.

**Net Weight:** 54 pounds (25 kg).

TYPE		CODE WORD	PRICE
1001-A	Standard-Signal Generator.....	ARGUS	\$975.00

PATENT NOTICE. See Note 4, page viii.





### TYPE 805-C STANDARD-SIGNAL GENERATOR

**USES:** The TYPE 805-C Standard-Signal Generator is designed primarily as a precision laboratory instrument for rapid and accurate testing of radio receivers. Because of its accuracy, wide frequency range, and high voltage output, it is a valuable instrument for laboratories engaged in research and design on radio receivers and allied apparatus, while its speed and simplicity of operation make it well adapted to production testing.

It can be used for testing television i-f circuits by the addition of a TYPE 1000-P6 Crystal Diode Modulator.

The TYPE 805-C is suitable for intermittent sweep applications. With the TYPE 1750-A Sweep Drive (page 144), the sweep range is  $\pm 1\%$  of the operating frequency.

**DESCRIPTION:** Functionally this instrument consists of (1) a carrier-frequency oscillator, (2) a tuned radio-frequency amplifier, (3) a resistive output attenuator and a voltmeter to read the output level, (4) a modulating oscillator (400 cps and 1000 cps) with a voltmeter for reading percentage modulation, and (5) a well-regulated power supply.

The oscillator and amplifier assemblies are virtually identical in construction, and the coil switching assemblies, as well as the tuning capacitors, are ganged and driven from common panel controls. Seven coils covering the frequency range from 16 kc to 50 Mc are carried on a rotary turret. An eighth coil position is also provided, so that an extra set of coils may be installed if desired. The turret is driven from a panel knob through a gear mechanism, which also brings into panel view

a frequency-range identification dial. As each coil is rotated into position, it is connected into circuit through silver-overlaid contact blades, which firmly engage silver-alloy brushes, mounted on the tuning capacitor. The contacts are mounted on polystyrene strips, ensuring both low capacitance and low dielectric losses.

The main tuning capacitors are exceptionally rugged, with cast frames and ball-bearings.

The output system consists of a vacuum-tube voltmeter, a resistive attenuator network, a 3-foot, 75-ohm output cable, and a TYPE 805-P1 Termination Unit. The effective output impedance at the panel terminals is nominally 75 ohms. The TYPE 805-P1 Unit permits a choice of three output impedances: 37.5, 7.1, or 0.75 ohms. The voltmeter reads the open-circuit output voltage directly for the 37.5-ohm termination. For the two lower impedances, the voltmeter reading is divided by 10 and 100, respectively. A standard broadcast-band dummy-antenna output is also provided.

The TYPE 805-P2 Termination Unit can be used to convert the 75-ohm output of the Generator to an effective 50-ohm output. With this Unit, the TYPE 1000-P, 50-ohm accessories can be used to provide a dummy antenna or a voltage divider (pages 92 and 93).

With either Termination Unit, the panel meter indicates the output voltage behind the effective impedance.

#### FEATURES:

➤ Output voltage continuously variable up to 2 volts across 37.5 ohms, 4 volts open circuit.



- Amplitude modulation up to 100%.
- Incremental-frequency dial with .01% frequency change per division.
- Simplified controls, well suited to production-line testing by unskilled personnel.
- Tuned amplifier minimizes reaction of output circuit on carrier frequency.

### SPECIFICATIONS

**Carrier Frequency Range:** 16 kc to 50 Mc, covered in seven direct-reading ranges: 16 to 50 kc, 50 to 160 kc, 160 to 500 kc, 0.5 to 1.6 Mc, 1.6 to 5.0 Mc, 5.0 to 16 Mc, 16 to 50 Mc. A spare range position is provided so that a special set of coils can be installed if desired.

**Frequency**

**Scale:** Logarithmic.

**Vernier Dial:** A slow-motion vernier drive dial is provided, by means of which frequency increments as small as .01% may be obtained.

**Accuracy:** Each range is direct reading to an accuracy of  $\pm 1\%$  of the indicated frequency.

**Stability:** Drift not greater than  $\pm 0.1\%$  on any frequency range with continuous operation for five hours.

**Sweeping:** Maximum sweep range with the TYPE 1750-A Sweep Drive is approximately 2%, i.e.,  $\pm 1\%$  of center frequency. Sweeping is not recommended for continuous or production line use.

**Output**

**Voltage Range:** Continuously adjustable from 0.1 microvolt to 2 volts. The output voltage (at the termination of the 75-ohm output cable) is indicated by a panel meter and seven-point multiplier. Maximum open-circuit voltage with termination removed is 4 volts.

**Voltage Accuracy:** For multiplier settings below 1 volt the maximum error in output voltage is the sum of the attenuator and voltmeter errors listed below. Maximum voltmeter error, up to 25 Mc, is  $\pm 5\%$  of indicated reading. Above 25 Mc an additional frequency error occurs, amounting to a total of  $\pm 7\%$  at 50 Mc. At  $\frac{1}{2}$  full scale and 50 Mc, there is also a transit-time error of  $-5\%$  in the voltmeter tube. Maximum attenuator error is as follows:

- Below 3 Mc,  $\pm (3\% + 0.1 \text{ microvolt})$
- 3 to 10 Mc,  $\pm (5\% + 0.2 \text{ microvolt})$
- 10 to 30 Mc,  $\pm (10\% + 0.4 \text{ microvolt})$
- 30 to 50 Mc,  $\pm (15\% + 0.8 \text{ microvolt})$

There is no error for the 1-volt multiplier setting.

**Impedance:** The output impedance at the panel jack is 75 ohms resistive. A 75-ohm output cable is provided, together with a termination unit that furnishes constant output impedances of 37.5, 7.1, or 0.75 ohms. The calibration of the panel voltmeter-multiplier combination is in terms of the actual voltage across the 37.5-ohm output. When the 7.1- and 0.75-ohm positions are used, the indicated output voltage must be divided by 10 and 100, respectively. A standard dummy-antenna output is also available at the termination unit.

The TYPE 805-P2 Termination Unit can be used to convert the effective output impedance of the Generator from 75 to 50 ohms. It also permits the use of several 50-ohm accessory units (pages 92 and 93).

**Modulation:** Continuously variable from 0 to 100%. The percentage of modulation is indicated by a panel meter to an accuracy of  $\pm 10\%$  of full scale up to 80%, for

- Tuned circuit is heavily damped to prevent side-band clipping.
- Minimum backlash in gear trains.
- Regulated power supply eliminates the effects of line-voltage fluctuations.
- Exceptionally good frequency stability.

carrier frequencies below 16 Mc;  $\pm 15\%$  for higher carrier frequencies.

Internal modulation is available at 400 cps and 1000 cps, accurate in frequency within  $\pm 5\%$ .

The generator can be modulated by an external oscillator. Approximately 10 volts across 500,000 ohms are required for 80% modulation. The over-all modulation frequency characteristic for constant audio input is as follows:

Carrier Frequency	Audio Range	Flatness
0.5 — 50 Mc	50 — 15,000 cps	$\pm 1 \text{ db}$
0.1 — 0.5 Mc	50 — 10,00 cps	$\pm 1.5 \text{ db}$
16 — 100 kc	50 cps — 10% of Carrier Frequency	$\pm 1.5 \text{ db}$

**Incidental Frequency Modulation:** On the highest carrier-frequency range the incidental frequency modulation is about .05% for 100% modulation, and .02% for 30% modulation. At lower carrier frequencies the frequency modulation is less than these percentages.

Above 20 Mc, for applications where incidental fm must be negligible or for wideband modulation, the TYPE 1000-P6 Crystal Diode Modulator should be used.

**Distortion and Noise Level**

**Envelope Distortion:** Less than 5% at a modulation level of 80% with a carrier frequency of 1 Mc.

**Carrier Noise Level:** At least 40 db below 80% modulation.

**Leakage:** The magnetic induction leakage is less than 5 microvolts per meter at a distance of 2 feet from the generator. The 3-foot output cable permits the receiver under test to be kept beyond this limit. Radiation fields are negligible.

**Tube Complement:**

1 — 6CS-G	2 — 2A3	1 — 6AL5
3 — 6L6	1 — 6SF5	1 — 6H6
1 — 5U4-G	1 — 0D3	1 — Amperite 3-4

**Terminals:** A TYPE 874 Coaxial Connector is provided for the output connection.

**Power Input:** 105 to 125 (or 210 to 250) volts, 40 to 60 cps. An electronic voltage regulator compensates for line-voltage fluctuations from 105 to 125 volts (or from 210 to 250 volts). Maximum input power is 150 watts.

The instrument will operate satisfactorily on power-supply frequencies up to 400 cps, provided that the supply voltage is at least 115 volts.

**Accessories Supplied:** TYPE 805-P1 Termination Unit, shielded output cable, TYPE CAP-22 Power Cord, and spare fuses.

**Other Accessories Available:** TYPE 805-P2 Termination Unit, TYPE 1000-P Accessories (pages 92 and 93) and TYPE 1750-A Sweep Drive (page 144).

**Mounting:** The panel is finished in gray crackle and the cabinet has a gray wrinkle finish.

**Dimensions:** Width 33, height 16, depth 13 inches (840 by 410 by 330 mm), over-all.

**Net Weight:** 118 pounds (54 kg).

TYPE		CODE WORD	PRICE
805-C	Standard-Signal Generator.....	LEPER	\$1975.00
805-P2	Termination Unit.....	ALTER	25.00

PATENT NOTICE: See Note 4, page viii.





## TYPE 1021 STANDARD-SIGNAL GENERATORS

40 TO 940 MEGACYCLES IN TWO MODELS

**USES:** These Standard-Signal Generators are as reliable and as convenient at very-high and ultra-high frequencies as conventional standard-signal generators are at much lower frequencies. They can be used to determine radio receiver and amplifier characteristics in the engineering laboratory and in production, as well as to supply power at vhf and uhf frequencies for bridges, slotted lines, and other measuring devices.

The simple TYPE 1000-P6 Crystal-Diode Modulator and a source of video signals, such as a standard television receiver tuned to a local television station, can be used to produce television picture modulation of the signal generator output on all vhf and uhf channels.

With the TYPE 1000-P7 Balanced Modulator, up to 100% amplitude modulation and pulsing with very low residual carrier level are possible at frequencies above 60 Mc.

The frequency can be swept over a range of about 10% by means of the TYPE 1750-A Sweep Drive, which can be attached to the slow-motion dial.

**DESCRIPTION:** Each TYPE 1021 Standard-Signal Generator is a compact instrument of

simple, rugged, durable design. For flexibility and economy, each signal generator is made up of two units mounted in a single cabinet. The power supply, modulator, and metering system comprise one unit, the TYPE 1021-P1 Power Supply, which occupies the left-hand side of the welded aluminum cabinet. The right-hand side of the cabinet houses either of the readily interchangeable carrier-oscillator units: The TYPE 1021-P2 UHF Unit (250 to 940 Mc), or the TYPE 1021-P3B VHF Unit (40 to 250 Mc).

As noted in the price table, individual tuning units can be furnished for use with one common power supply and cabinet assembly. Power supply and cabinet assembly can also be purchased separately.

These generators have provisions for external and 1000-cycle sine-wave internal amplitude modulation.

The frequency-determining elements are butterfly circuits. A mutual-inductance-type attenuator, with a dial calibrated in both voltage and db below one milliwatt, is used.

### FEATURES:

➤ Wide frequency coverage in single dial range.



- High output.
- Accurately known output voltage, frequency, and impedance.
- Auxiliary calibration in db below one milliwatt.

- Good frequency stability.
- Excellent shielding.
- Ease of operation.
- Readily interchangeable VHF and UHF oscillator units.
- A wide variety of coaxial accessories.

### SPECIFICATIONS

#### TYPE 1021-AU UHF STANDARD-SIGNAL GENERATOR

**Frequency**

**Carrier Range:** 250 Mc to 940 Mc in one band.

**Accuracy:** Direct reading to  $\pm 1\%$ . Approximately 8 turns of the 100-division slow-motion dial cover the range of the main dial.

**Sweeping:** The TYPE 1750-A Sweep Drive attached to the slow-motion dial will sweep approximately 5% and 15% at the low- and high-frequency ends of the range, respectively.

**Output:** (1) As voltage generator with accurately known output impedance and (2) in terms of available power (db below one milliwatt).

**Voltage Range:** Continuously adjustable from 0.5 microvolt to 1 volt behind 50 ohms.

**Voltage Accuracy:** Over-all accuracy of output is better than  $\pm 2$  db. The accuracy of voltmeter calibration between 0.5 and 1.0 volt is better than  $\pm 1$  db. The accuracy of the attenuator-dial calibration for voltages between 1.0 microvolt and 0.1 volt is better than  $\pm 0.5$  db; from 0.1 volt to 0.5 volt, better than  $\pm 1$  db.

**Impedance:** 50 ohms  $\pm 10\%$  following the output meter.

**Power:** Directly calibrated from 0 to 126 db below 1 milliwatt into 50 ohms.

**Amplitude Modulation:** Adjustable, 0 to 50%. Internal, 1000 cps  $\pm 5\%$ . External, flat within 3 db from 30 cps to 15 kc. For 50% modulation, external audio oscillator must supply 18 volts across a 100-kilohm load. TYPE 1210-C Unit R-C Oscillator is recommended.

**Incidental Frequency Modulation:** For 50% amplitude modulation the incidental fm is approximately 100 parts per million for frequencies up to 400 Mc and is approximately 1000 parts per million at 920 Mc. When lower values of incidental fm are required, the TYPE

1000-P6 Crystal Modulator, or the TYPE 1000-P7 Balanced Modulator (pages 92 and 93) is recommended.

**Distortion and Noise Level**

**Envelope Distortion:** Approximately 5% at 50% modulation.

**Carrier Noise Level:** Corresponds to about 0.2% modulation.

**Leakage:** Stray fields and residual output voltage are sufficiently low for measurements on receivers of one-microvolt sensitivity.

**Tube Complement:** Two 0C3; one each 6X5-GT/G, 6K6-GT, Sylvania TYPE 6481, Amperite 6-4.

**Terminals:** TYPE 874 Coaxial Terminals are provided for the output connection.

**Power Input:** 105 to 125 (or 210 to 250) volts, 50 to 60 cycles. Power input is approximately 50 watts at 115 volts.

This instrument will operate satisfactorily on power-supply frequencies up to 400 cycles, provided that the supply voltage is between 110 and 125 volts.

**Accessories Supplied:** TYPE 874-R22 Patch Cord, TYPE 874-C58 Cable Connector, TYPE CAP-22 Power Cord, and spare fuses.

**Other Accessories Available:** TYPE 874 Fixed Attenuators, TYPE 874 Coaxial Elements (pages 43 and 48), TYPE 1000-P6 Crystal Modulator, TYPE 1000-P7 Balanced Modulator (pages 92 and 93).

**Mounting:** The aluminum cabinet has a wrinkle finish. The left-hand side houses the TYPE 1021-P1 Power Supply; the right-hand side houses the TYPE 1021-P2 UHF Unit. Panels in gray are crackle-finished aluminum.

**Dimensions:** Width  $20\frac{1}{4}$ , height  $13\frac{1}{2}$ , depth 11 inches (515 by 345 by 280 mm), over-all.

**Net Weight:**  $37\frac{1}{2}$  pounds (17 kg).

#### TYPE 1021-AV VHF STANDARD-SIGNAL GENERATOR

Same as TYPE 1021-AU (above) except as noted.

**Carrier Frequency Range:** 40 to 50 Mc in one band, 50 to 250 Mc in another.

**Sweeping:** The TYPE 1750-A Sweep Drive, attached to the slow-motion dial, will sweep the frequency approximately 4, 9, and 20% at 40, 50, and 250 Mc, respectively.

**Incidental Frequency Modulation:** For 50% amplitude modulation the incidental fm is approximately 100 parts per million for frequencies up to 100 Mc, and is

approximately 500 parts per million at 250 Mc. When lower values of incidental fm are required, the TYPE 1000-P6 Crystal Modulator or the TYPE 1000-P7 Balanced Modulator (pages 92 and 93) is recommended.

**Tube Complement:** Same as listed above, except 12AT7 Oscillator (instead of 6481).

**Mounting:** Cabinet is same as for TYPE 1021-AU, above. Generator consists of the TYPE 1021-P1 Power Supply and TYPE 1021-P3B VHF Unit.

TYPE		CODE WORD	PRICE
1021-AU	UHF Standard-Signal Generator, 250-940 Mc	EVADE	\$725.00
1021-AV	VHF Standard-Signal Generator, 40-250 Mc.	EVENT	740.00
1021-P2	UHF Oscillator Unit* only, 250-940 Mc.	ETHIC	435.00
1021-P3B	VHF Oscillator Unit* only, 40-250 Mc.	EVOKE	450.00
1021-P1	Power Supply and cabinet assembly.	EXTRA	290.00

PATENT NOTICE. See Notes 4 and 10, page viii.

\* Less power supply unit and cabinet. Can replace oscillator unit in any signal generator listed above, to provide additional frequency range.





### TYPE 1000-P SIGNAL-GENERATOR ACCESSORIES

#### TYPE 1000-P3 VOLTAGE DIVIDER

This voltage divider, used with the TYPE 1001-A Standard-Signal Generator, provides a known voltage across a 1-ohm resistor, which can be inserted in series with a loop antenna for testing loop receivers.

It plugs into the output jack of the signal generator and divides indicated output voltage by a factor of 100.

**Input Impedance:** 50 ohms.

**Output Impedance:** 1 ohm.

**Net Weight:** 3¼ ounces (0.1 kg).

#### TYPE 1000-P4 DUMMY ANTENNA

Connected to the terminated output of a standard-signal generator of 50-ohm output impedance (25 ohms), this dummy antenna provides the output characteristics specified by the Institute of Radio Engineers in 1948 "Standards on Radio Receivers, Methods of Testing

#### TYPE 1000-P5 VHF TRANSFORMER—50 Ohms, Grounded, to 300 Ohms, Balanced

The TYPE 1000-P5 VHF Transformer is designed to plug into a standard-signal generator having a 50-ohm unbalanced output and to produce an equal, balanced, open-circuit voltage behind a 300-ohm balanced impedance for rf measurements of fm and receivers.

One end of the transformer is terminated in a socket designed to receive the Alden TYPE HA902P Connector for standard 300-ohm open parallel-wire line; the other end has a TYPE 874 Coaxial Connector.

**Dimensions:** Length 4¾, diameter ¾ inches (115 and 23 mm).

**Net Weight:** 3½ ounces (0.1 kg).

#### TYPE 1000-P6 CRYSTAL DIODE MODULATOR

This absorption-type modulator is an inexpensive means of producing fm-free amplitude modulation and is useful for testing radio and television receivers.

The crystal diode resistance varies with the voltage across it and thus can be modulated by an ac voltage. Inserted between generator and load, the modulator produces variations in amplitude corresponding to the variations in resistance.

#### SPECIFICATIONS

**Carrier Frequency Range:** 20 to 1000 Mc. The insertion loss increases 10 db at a carrier frequency of 10 Mc.

**Modulating Frequency Range:** 0 to 5 Mc. Response is approximately 2 db down at 5 Mc.

**Impedance:** Designed for use with a 50-ohm source, 50-

ohm load. Impedance at modulation terminals is approximately 600 ohms.

**Amplitude-Modulation Broadcast Receivers.?"**

**Net Weight:** 3¼ ounces (0.1 kg).

#### TYPE 1000-P10 TEST LOOP

With this shielded test loop, radio receivers with loop antennas can be tested by the preferred method of the 1948 "Standards on Radio Receivers, Methods of Testing Amplitude-Modulation Broadcast Receivers," published by the Institute of Radio Engineers. The 3-turn loop is enclosed in aluminum tubing for electrostatic shielding. Circuit constants are chosen to make the field strength in volts per meter, at a distance of 19 inches from the loop, equal to one-tenth the signal generator output in volts, with a 50-ohm generator.

**Dimensions:** Height 16½, width 11¾, depth 3½ inches (420 by 299 by 89 mm) over-all.

**Net Weight:** 4½ pounds (2.1 kg).

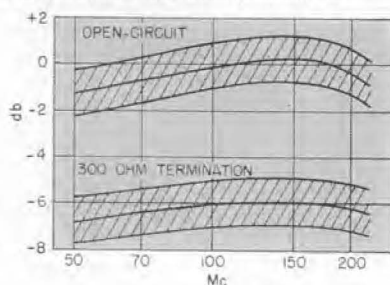

ohm load. Impedance at modulation terminals is approximately 600 ohms.

**Modulation:** With 50 millivolts rf input, 30% amplitude modulation is obtainable at carrier frequencies between 20 and 1000 Mc. For optimum sine-wave modulation, an average crystal requires 1.5 volts bias, and the insertion loss is about 12 db. Approximately 0.2 volt rms at modulation terminals will produce 30% modulation. Maximum percentage modulation at 1000 Mc is about 30%. Maximum peak modulation voltage is 4 volts.

**Terminals:** The rf and modulating terminals are TYPE 874 Coaxial Connectors. Modulation terminals accept either a TYPE 874 Coaxial Connector or a TYPE 274-M Plug. Bias terminals are TYPE 938 Binding Posts.

**Crystal Diode:** 1N21B.

**Accessories Supplied:** One TYPE 274-MB Plug.





**Other Accessories Required:** Terminal adaptors (pages 42 and 240), unless generator and load have TYPE 874 Coaxial Connectors; 1.5-volt battery for fixed bias, or a 3-volt battery and a 10,000-ohm rheostat for adjustable bias.

**Accessories Available:** TYPE 874 Fixed Attenuators, TYPE 874-R20 Patch Cord, TYPE 1000-P5 VHF Transformer, TYPE 874-Q Coaxial Adaptors.

**Dimensions:** Height 4, width 5, depth 1 1/16 inches (105 by 130 by 27 mm) over-all.

**Net Weight:** 1 pound (0.46 kg).

Typical modulation characteristics for the Type 1000-P6 Crystal Diode Modulator at various carrier frequencies.



## TYPE 1000-P7 BALANCED MODULATOR

### FOR 100% LINEAR AM AND PULSE MODULATION

**USES:** This instrument is an insertion-loss modulator for pulse and sine-wave modulating rf output of generators over the carrier-frequency range of 60 to 2300 Mc. It is particularly useful for pulse modulation where a high degree of carrier suppression is desired with good rise-time characteristics, and for linear-modulation systems where 100% modulation is required over a modulating frequency of 0 to 20 Mc. It can be used for tests on television and radar receivers, microwave relay systems, telemetering circuits and narrow-band systems where incidental fm must be negligible.

The Balanced Modulator is recommended for use with the TYPE 1217-A Unit Pulser or TYPE 1391-B Pulse, Sweep, and Time-Delay Generator for pulse-modulat-

ing output of TYPE 1021-A Standard-Signal Generator. **DESCRIPTION:** Two crystal diodes are used in separate signal paths between input and output. In one path a coaxial phasing line, set to an odd multiple of one-half wave-length at the carrier frequency, is inserted. A simple high-pass filter is included in the output circuit.

For small rf signals the impedances of the diodes can be controlled by varying the applied bias. The diode shunt capacity is neutralized in the phasing line.

Balance and bias controls are provided for completely or partially balancing out the carrier.

The modulator features high carrier suppression for pulse applications, fast rise time, extremely low incidental frequency modulation.

### SPECIFICATIONS

**Carrier-Frequency Range:** 60 to 2300 Mc.

**Modulation-Frequency Range:** Flat, 0 to 20 Mc. For pulsing, rise-time is less than .02 microsecond.

**Impedance:** The input and output impedances are functions of the bias and modulating voltages. Source and load impedances should be 50 ohms. Impedance at modulation input is 50 ohms  $\pm 5\%$ . Whenever the attenuation can be tolerated, a TYPE 874-G20 (20 db) or a TYPE 874-G10 (10 db) Fixed Attenuator should be used at the input and output.

**Modulation:** Double-sideband, suppressed-carrier modulation, pulse modulation with 60-db carrier suppression between pulses, and 100% amplitude modulation throughout carrier frequency range. One volt, peak, at the modulation terminals, will produce full rf output from zero output initial condition.

**RF Output:** 10 millivolts, maximum, into 50 ohms on pulses or at modulation peaks, with a source of 50 millivolts behind 50 ohms.

Higher input and output voltages are permissible if bias and balance readjustments are made for each change in level. The rf source must not exceed 0.5 volt behind 50 ohms, or crystal diodes may be damaged.

**Bias Supply:** Self-contained battery of flashlight cells.

**Terminals:** TYPE 874 Coaxial Connectors. Adaptors are described on pages 42 and 240.

**Crystal Diodes:** Two TYPE 1N21-B.

**Accessories Supplied:** One TYPE 1000-P7-28, 40-cm Cable;

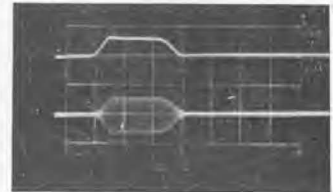
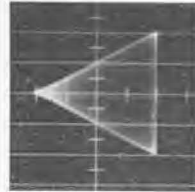

(Left) Amplitude modulation characteristic at 900 megacycles. Peak r-f output is 10 millivolts; r-f input, 50 millivolts. (Right) Oscillogram showing modulation pulse and r-f output pulse. Pulse duration is 0.25  $\mu$ sec with .05  $\mu$ sec rise time. Carrier frequency is 60 megacycles. Scale is 0.1  $\mu$ sec per horizontal division.

one TYPE 1000-P7-28-2, 80-cm Cable; one TYPE 874-C58 Cable Connector.

**Other Accessories Required:** Suitable coaxial cable for connecting modulation source. TYPE 874-R33 (page 44) is recommended.

**Accessories Available:** TYPE 874-G Fixed Attenuators (page 48); TYPE 1000-P5 VHF transformer; TYPE 874-R Patch Cords (page 44).

**Dimensions:** (fully extended) Height 3, width 30, depth 5 inches (77 by 765 by 130 mm) over-all. Length with line telescoped — 20 inches (510 mm).

**Net Weight:** 6 pounds (2.8 kg).

TYPE	DESCRIPTION	CODE WORD	PRICE
1000-P3	100:1 Voltage Divider	ARMOR	\$20.00
1000-P4	Dummy Antenna	ARROW	16.00
1000-P5	VHF Transformer	ARSON	27.50
1000-P6	Crystal Diode Modulator	APPLE	40.00
1000-P7	Balanced Modulator	AWAKE	225.00
1000-P10	Shielded Test Loop	ARRAY	50.00

PATENT NOTICE. See Note 4, page viii. All signal generators and accessories are equipped with TYPE 874 Coaxial Connectors.





# OSCILLATORS

A source of power or test voltage is a prerequisite to nearly all types of measurements. Since 1919 the General Radio Company has been supplying laboratory oscillators for this purpose and has always pioneered in new designs and circuits.

Functionally, these oscillators can be grouped under the following classifications:

(1) *LC and Resonant-Cavity Types* — the frequency is determined by inductive and capacitive elements or by resonant cavities.

(2) *Beat-Frequency Types* — the output frequency is the difference between the frequencies of a variable and a fixed oscillator. This type can cover several decades of frequency in one band with a single control.

(3) *RC Degenerative Types* — the frequency is determined by resistive and capacitive elements, and the circuit is highly degenerated except at the pass frequency.

(4) *Klystron Types*, in which the output frequency is produced by velocity modulation of the electron stream.

The General Radio Company manufactures all these functional types; their characteristics are tabulated on the next page.

**LC and Resonant-Cavity Types:** The LC oscillator, because of its stability, good waveform, and efficiency, finds many uses where fixed audio frequencies are needed.

General Radio makes several audio-frequency oscillators of this type, among them the TYPE 1307-A Transistor Oscillator, a miniature instrument designed primarily for calibrating sound measuring equipment, and the TYPE 1214 Unit Oscillators, conventional vacuum-tube types, which are useful for modulating high-frequency oscillators and as bridge power sources.

At radio frequencies where tuning can be accomplished by air capacitors, the LC circuit is the best and most economical frequency-determining system. The TYPE 1330-A Bridge Oscillator uses tuned circuits to cover a frequency range of 10,000:1. The TYPES 1211-B, 1208-B, 1215-B, 1209-B and 1209-BL Unit Oscillators together with the TYPE 1361-A UHF Oscillator cover a wide range of frequencies from the standard radio broadcast band up through the uhf television band. All of these employ unique tuned circuits, in which the inductance and capacitance are varied simultaneously. Many of them use the General-Radio-developed butterfly circuit, which has no sliding or wiping contacts.

At frequencies above 1000 Mc, circuits with distributed constants are used. The TYPE 1218-A Unit Oscillator covers a frequency range from 900 to 2000 Mc with ganged quarter-wave lines.

**Klystron:** The TYPE 1220-A Unit Klystron Oscillator is a klystron power supply which covers frequencies from 2700 to 7500 Mc with plug-in klystron tubes, each of which operates at a single output frequency or is adjustable over a limited band of frequencies.

The rf oscillators can all be amplitude modulated with sine waves, and the TYPE 1218-A and TYPE 1220-A can be directly square-wave and pulse modulated as well. The TYPE 1220-A also has provision for frequency modulation up to deviations of  $\pm 7.5$  Mc.

The Unit Oscillators operating above 50 Mc can be pulse or square-wave modulated by the TYPE 1264-A Modulating Power Supply, and can be held to a constant output amplitude vs frequency with the TYPE 1263 Amplitude-Regulating Power Supply. All can also be mechanically swept with the TYPE 1750-A Sweep Drive.

**Beat-Frequency Types:** The first commercial beat-frequency oscillator was produced by General Radio in the middle 1920's. As the development of tubes and circuits has progressed, increasingly better models have been developed, culminating in the present TYPE 1304-B Beat-Frequency Audio Generator whose logarithmic scale greatly facilitates frequency-response measurements, and which can be driven by the TYPE 1521-A Graphic Level Recorder for automatic plotting.

A still more versatile instrument is the TYPE 1300-A Beat-Frequency Video Generator, which can test circuits and networks by four methods: point-by-point, square-wave, sweep-frequency, and automatic plotting.

**RC Types:** The RC degenerative type is an original patented General Radio development. Two models are offered, the TYPE 1301-A, whose primary characteristic is low distortion, and the TYPE 1302-A, designed for a wide frequency range. Two other RC oscillators use a phase-shift circuit: the TYPE 1210-C, a small, versatile instrument, which produces either sine-wave or square-wave output over a wide frequency range, and the TYPE 1305-A, which generates frequencies as low as 0.01 cycle per second, with single-phase, three-phase and four-phase output as well as an output continuously variable in phase over  $360^\circ$ .







## OSCILLATORS

TYPE	NAME	CLASS	FREQUENCY RANGE	MAXIMUM OUTPUT	OPEN-CIRCUIT VOLTS	NOMINAL LOAD IMPEDANCE	HARMONIC DISTORTION	POWER SUPPLY	SEE PAGE NO.
1300-A	Beat-Frequency Video Generator	Beat-Frequency	20 cps-12 Mc	30 mw 3 mw	10	820 ohms 75 ohms	<1%, 20 cps-20 kc; <4%, 20 kc-12 Mc Sine Wave	AC Line	104
1304-B	Beat-Frequency Audio Generator	Beat-Frequency	20-20,000 cps 20,000-40,000 cps	1 w	50	600 ohms, balanced or grounded	<1%	AC Line	100
1301-A	Low-Distortion Oscillator	RC Degenerative	20-15,000 cps (27 fixed frequencies)	18 mw	6.6	600 ohms, balanced or grounded	<0.1%	AC Line	98
1302-A	Oscillator	RC Degenerative	10-100,000 cps	100 mw 40 mw 20 mw 80 mw	30 10 5 20	5000 ohms, grounded 600 ohms, balanced 300 ohms, grounded 5000 ohms, grounded	<1%	AC Line	99
1305-A	Low-Frequency Oscillator	RC	.01 to 1000 cps	170 mw per phase	10	600 ohms	<1%	AC Line	96
1214-D	Unit Oscillator	Tuned Circuit	120 cps	400 mw	60	Matched	<3%	AC Line	106
1307-A	Transistor Oscillator	Tuned Circuit	400 and 1000 cps	6 mw	2	600 ohms	<5%	Mercury Cells	106
1214-A	Unit Oscillator	Tuned Circuit	400 and 1000 cps	200 mw	80	8000 ohms grounded or ungrounded	<3%	AC Line	106
1210-C	Unit RC Oscillator	RC	20 cps-0.5 Mc	80 mw 40 mw 90 mw	7 45 30	50 to 1250 ohms 14,000 ohms 2500 ohms	<1.5% <5% Square Wave	Unit Power Supply	102
1214-M	Unit Oscillator	Tuned Circuit	1 Mc	300 mw	7	50 ohms	<3.5%	AC Line	106
1330-A	Bridge Oscillator	Tuned Circuit	60, 400, 1000 cps 5 kc-50 Mc	0.75 w 1 w	12 10	50 ohms 20-80 ohms	<3%	AC Line	107
1211-B	Unit Oscillator	Tuned Circuit	0.5-5 Mc 5-50 Mc	1 mw 200 mw		50 ohms		Unit Power Supply	108
1208-B	Unit Oscillator	Sliding-Contact Tuned Circuit	65-500 Mc	100 mw		50 ohms		Unit Power Supply	110
1209-BL	Unit Oscillator	Butterfly Tuned Circuit	180-600 Mc	300 mw		50 ohms		Unit Power Supply	110
1209-B	Unit Oscillator	Butterfly Tuned Circuit	250-920 Mc	200 mw		50 ohms		Unit Power Supply	110
1215-B	Unit Oscillator	Semi-Butterfly	50-250 Mc	80 mw		50 ohms		Unit Power Supply	110
1361-A	UHF Oscillator	Butterfly Tuned Circuit	450-1050 Mc	125 mw		50 ohms		Unit Power Supply	109
1218-A	Unit Oscillator	Coaxial Line Tuned Circuit	900-2000 Mc	200 mw		50 ohms		Unit Power Supply	110
1220-A	Klystron Oscillator	Velocity-Modulated	2700-3275 Mc 3400-4910 Mc 5100-5900 Mc 5925-7425 Mc	100 mw		50 ohms		Unit Power Supply	113

Audio and Low Frequency

Medium and High Frequency

VHF and UHF

SHF





## TYPE 1305-A LOW-FREQUENCY OSCILLATOR

SINGLE-PHASE OR POLYPHASE OUTPUT .01 TO 1000 CPS

**USES:** This oscillator is primarily a source of sinusoidal signals of very low frequency and has many uses in the development and test of servomechanisms, low-frequency amplifiers, recorders, geophysical equipment, medical instruments, and electrical analogs of mechanical systems.

Its usefulness in a variety of applications is greatly enhanced by its three-phase output ( $0^\circ$ ,  $120^\circ$ ,  $240^\circ$ ), any one phase of which can be used as a single-phase source.

With suitable amplifiers, this oscillator can operate as a variable-frequency drive for the study of the performance of 2-phase or 3-phase machines, such as motors and synchros.

An adaptor provides a four-phase output ( $0^\circ$ ,  $90^\circ$ ,  $180^\circ$ , and  $270^\circ$ ), which is useful for applications requiring quadrature signals, such as component resolution and circular oscilloscope sweeps.

An additional output is continuously variable in phase from  $0^\circ$  to  $360^\circ$  with one complete turn of a dial. Phase measurements at these low frequencies are thereby made possible by Lissajous-pattern techniques. It can also be used to measure the gain and phase-shift of four-terminal devices and to determine the complex transfer characteristics of amplifiers and servomechanisms.

**DESCRIPTION:** The TYPE 1305-A Low-Frequency Three-Phase Oscillator uses three independent RC phase-shift networks in a phase-shift oscillator circuit. In order to achieve very-low-frequency operation with components of practical size, the Miller effect is used

to increase the effective size of the capacitors. The RC phase-shift networks are connected as low-pass filters, and the entire oscillator is direct coupled for circuit stability. A network of biased diodes serves as an amplitude regulator, which provides an extremely high degree of amplitude stabilization, independent of frequency. Cathode-follower circuits provide low-distortion, low-impedance outputs. A six-phase rectifier and meter, connected across the output, provide a direct indication of output voltage with only slight ripple even at the lowest frequencies. An output attenuator permits 60-db reduction in output level for convenience in studies of high-gain systems.

The phase shifter is composed of a potentiometer and a purely resistive network which, fed from the three-phase output, produces an output signal that is constant in amplitude and continuously variable in phase, independent of frequency.

The Four-Phase Output Adaptor is a plug-in unit which contains a purely resistive network to convert the three-phase to a four-phase output, again completely independent of frequency.

### FEATURES:

- Low-frequency output, .01 to 1000 cps.
- Three-phase output ( $0^\circ$ ,  $120^\circ$ , and  $240^\circ$ ) provided, and four-phase ( $0^\circ$ ,  $90^\circ$ ,  $180^\circ$ , and  $270^\circ$ ) output available with adaptor.
- Additional output signal with continuously variable phase for convenient phase measurements.
- Meter measures output voltage directly.



with low ripple even at lowest frequencies.

- Excellent amplitude stability and low distortion.
- Polystyrene-dielectric capacitors are used on low-frequency ranges.

- Logarithmic frequency scale.
- Regulated power supply eliminates effect of line-voltage variations.
- Output step attenuator and output voltmeter provide known output levels over 80-db range.

### SPECIFICATIONS

#### Frequency

**Range:** .01 to 1000 cps in five ranges.

**Control:** The frequency control dial is engraved from 1 to 10 cps. A range switch multiplies the scale frequencies by .01, 0.1, 1, 10, and 100.

**Accuracy:**  $\pm 2\%$ .

**Stability:** Warm-up drift is less than 1% in the first ten minutes, less than 0.2% in the next hour.

#### Three-Phase Output

**Maximum Amplitude:** At least 10 volts rms, open-circuit, line-to-neutral, behind 600 ohms in each phase, constant with frequency to  $\pm 5\%$ . Phase voltages are equal to each other within  $\pm 2\%$ .

**Impedance:** The DIRECT position of the output attenuator switch provides 75 ohms per phase but must not be loaded with less than 600 ohms per phase, wye-connected, or 1800 ohms per phase, delta-connected. A neutral terminal is provided. Phase difference between adjacent phases is  $120^\circ \pm 2^\circ$ .

**Maximum Power:** 167 milliwatts per phase, maximum, into a 3-phase wye-connected load of 600 ohms per phase.

**Distortion:** Total harmonic content is less than 2% for all output values, for all frequencies and for any load except in the DIRECT position of the OUTPUT ATTENUATOR switch. For the DIRECT position of the OUTPUT ATTENUATOR switch, total harmonic content is less than 2% for any wye-connected load of more than 600 ohms per leg or delta-connected load of more than 1800 ohms per phase.

**Meter:** Deflection is subject to a ripple frequency six times the oscillator frequency. At the lowest frequencies,

amplitude indications vary between +5% and -10% of the true rms value.

#### Four-Phase Output (from plug-in adaptor)

**Maximum Amplitude:** At least 5 volts rms, line to neutral.

**Impedance:** 600 ohms.

**Phase Accuracy:**  $\pm 3^\circ$ .

#### Variable-Phase Output

**Range:** 0 to  $360^\circ$ .

**Phase Accuracy:**  $\pm 3^\circ$ .

**Maximum Amplitude:** Approximately 0.8 volts rms, max, constant with phase setting to  $\pm 5\%$ .

**Impedance:** Variable 15,000 ohms, max.

**Distortion:** Less than 5%.

**AC Hum:** Less than 100 millivolts in output.

**Tube Complement:** Four 6197; three each 6BH6, 5963; one each 5651, 12AX7, 6080; six 1N599A crystal diodes; eight 1N191 crystal diodes; one 5V18 crystal diode.

**Power Input:** 105 to 125 (or 210 to 250) volts, 50 to 60 cps. Total power consumption is 165 watts. Instrument will operate satisfactorily on power-supply frequencies up to 400 cps. Three-wire power cord.

**Accessories Supplied:** TYPE CAP-22 Power Cord, three TYPE 274-MB Double Plugs, spare fuses, Four-Phase Output Adaptor TYPE 1305-A-P1.

**Mounting:** Aluminum panel and cabinet, in gray finish, for bench (TYPE 1305-AM) or relay-rack (TYPE 1305-AR) use. See page 242 for cabinet description.

**Dimensions:** Width 19, height 7, depth 15 inches (483 by 178 by 381 mm), over-all.

**Net Weight:** 35 pounds (15.9 kg).

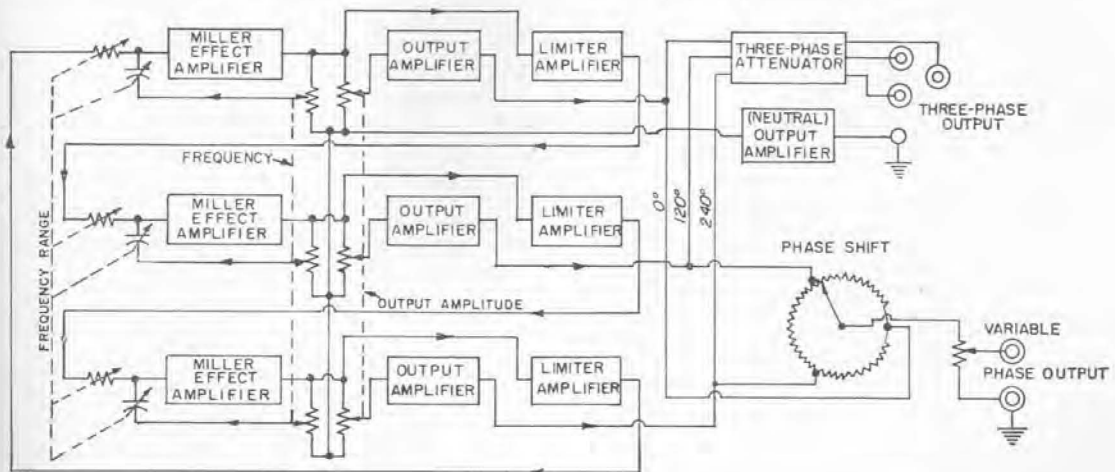

TYPE		CODE WORD	PRICE
1305-AM	Low-Frequency Oscillator, Bench Model . . . . .	DEBUT	\$940.00
1305-AR	Low-Frequency Oscillator, Relay-Rack Model . . . . .	DONOR	940.00



### TYPE 1301-A LOW-DISTORTION OSCILLATOR



This oscillator has an exceptionally pure waveform, which makes it an ideal source of test voltage for distortion measurements or a power source for audio bridge measurements.

Frequencies are selected instantly by push-button controls and include those recommended by the Federal Communications Commission for distortion measurements on broadcast transmitters. Thus, in combination with the TYPE 1932-A Distortion and Noise Meter (page 227), it provides a fast and accurate means for making these transmitter tests.

When this oscillator is used as a bridge power source, null balance is found more precisely and easily because of the low level of harmonic voltage present at the null point.

The inverse-feedback RC circuit used in this oscillator was invented and developed by the General Radio Company. Separate feedback

networks control the frequency and amplitude, thus providing high stability and low distortion.

Mica capacitors and wire-wound resistors, chosen for maximum stability, are used in the frequency-determining network. Amplitude control is automatic, normally requiring no adjustment as various frequencies are selected.

#### FEATURES:

- > Very low distortion.
- > Excellent frequency stability.
- > Output voltage within 1 db of 400-cps level.
- > Instant selection of any one of 27 test frequencies by push-button control.
- > Lower frequency range of 2 to 15 cps available from plug-in range-extension unit.
- > Any other frequency between 2 and 15,000 cps can be obtained by plug-in resistors.

#### SPECIFICATIONS

##### Frequency

**Range:** 27 fixed frequencies between 20 and 15,000 cps. (Also 2 to 15 cps by use of range extension unit.)

**Control:** A frequency of 20, 25, 30, 40, 50, 60, 75, 100, or 150 cps is selected by a push button. Push-button-operated frequency multipliers of 1, 10, and 100 are provided.

**Accuracy:**  $\pm(1\frac{1}{2}\% + 0.1 \text{ cps})$ .

**Stability:** Changes in ac line voltage or output load have no effect upon the frequency. Drift is not greater than .02% per hour after the first 10 minutes.

##### Output

**Impedance:** Selected by push button; 600 ohms, balanced; 600 or 5000 ohms, grounded.

With balanced load, 600-ohm balanced output is balanced for all audio frequencies. The 5000-ohm output varies with potentiometer setting between 1000 and 6000 ohms. Potentiometer also has slight effect on 600-ohm grounded impedance.

**Voltage (Max):** 30 volts, open circuit; 6.6 volts with 600-ohm load; constant with frequency within  $\pm 1 \text{ db}$ .

**Power:** 18 milliwatts into 600 ohms; 100 milliwatts into 5000 ohms.

##### Distortion and Noise Level

**Distortion:** 5000-ohm output, not more than 0.1%;

600-ohm output, not more than 0.1% between 50 and 7500 cps, and not more than 0.25% below 50 cps. With range-extension unit (2 to 15 cps), distortion may increase by 1%.

**AC Hum:** Not more than .05% of output voltage.

**Tube Complement:** One each, 6X5-GT/G, 6W6-GT, 6SL7-GT, 6D3/VR-150, 6Y6-G, 6SK7, 6SQ7-GT, 6SJ7.

**Terminals:** Jack-top binding posts with standard  $\frac{3}{4}$ -inch spacing, a ground terminal and a standard Western Electric double output jack on the front panel; duplicate output terminals on the rear of the instrument.

**Power Input:** 105 to 125 (or 210 to 250) volts, 25 to 60 cps, 45 watts. Specify line voltage and frequency when ordering.

Operation from 400-cps supply is possible if line voltage is between 110 and 125 volts; power-frequency hum is increased at 200- and 400-cps output.

**Accessories Supplied:** CAP-22 Power Cord, multipoint connector, TYPE 1301-201 Plug Assembly, spare fuses.

**Mounting:** Relay-rack panel. End frames are available for table mounting. (See price table below.)

**Panel Finishes:** Standard General Radio gray crackle. Certain other standard finishes to match transmitters can be supplied at small extra cost.

**Dimensions:** Width 19, height 7, depth  $13\frac{1}{2}$  inches (475 by 180 by 345 mm), over-all.

**Net Weight:**  $31\frac{1}{2}$  pounds (14.5 kg).

TYPE		CODE WORD	PRICE
1301-A	Low-Distortion Oscillator.....	OZONE	\$595.00
1301-P1	Range Extension Unit (2 to 15 cps).....	OVATE	80.00
FRI-412	Aluminum End Frames.....	ENDFRAMDIG	13.00 Pair





## TYPE 1302-A OSCILLATOR

**USES:** The wide range and the excellent frequency and amplitude stabilities of this oscillator make it a superior source of power for bridges and other measurement networks.

**DESCRIPTION:** This instrument is an RC oscillator employing an inverse-feedback circuit. The frequency-determining network is a Wien bridge, in which the capacitive elements are controlled by the main frequency dial, and resistive elements are selected by a range switch.

The amplitude of oscillation is held constant by feedback through a second bridge section, one arm of which is a nonlinear resistance. A buffer amplifier ahead of the output control minimizes reaction on the oscillator frequency.

Both balanced and grounded outputs are provided.

**FEATURES:**

- Wide frequency range, 10 to 100,000 cps.
- Excellent frequency stability.
- Low harmonic distortion.
- Semilogarithmic scale eliminates crowding at the low-frequency end and still allows precise setting of high frequencies.
- Voltage regulation in the power supply removes effects of line-voltage transients and allows the instrument to operate over a wide range of supply voltages.

### SPECIFICATIONS

**Frequency**

**Range:** 10 to 100,000 cps in four ranges.

**Control:** The main control dial is engraved from 10 to 100 cps. Four multiplier switches multiply the scale frequencies by 1, 10, 100, or 1000.

**Accuracy:**  $\pm (1\frac{1}{2}\% + 0.2 \text{ cps})$ .

**Stability:** Warm-up drift is less than 1% in the first ten minutes, less than 0.2% during the next hour.

**Output**

**Impedance:** Balanced 600 ohms and grounded 5000 ohms. The internal impedance of the 600-ohm output is constant at 550 ohms; if the LOW output terminal is grounded it becomes 300 ohms, grounded. In the 5000-ohm output impedance position (for 5000-ohm loads), the internal impedance of the oscillator averages approximately 400 ohms.

**Voltage:** At least 20 volts open-circuit on 5000-ohm output, and 10 volts open-circuit on 600-ohm output,  $\pm 1.0$  db over the entire frequency range.

**Power:** 80 milliwatts, maximum, into a 5000-ohm load; 40 milliwatts, maximum, into a balanced 600-ohm load; 20 milliwatts into a 300-ohm load.

**Distortion and Noise Level**

**Distortion:** Less than 1% at normal loads. Considera-

ble deviations from nominal load impedances do not appreciably affect the distortion.

**AC Hum:** 5000-ohm output, 24 millivolts, maximum; 600-ohm output, 12 millivolts, maximum.

**Tube Complement:** Two each, 6SL7-GT, 6W6-GT. One each, 6AK6, 6F6, 6V6-GT, 6J5-GT, 5V4-G, 0D3.

**Terminals:** Jack-top TYPE 938 Binding Posts with standard  $\frac{3}{4}$ -inch spacing. The separate ground terminal has a strap that can be used to ground the LOW output terminal. Output is also available at a multipoint connector in the rear of the instrument. A mating connector is supplied.

**Power Input:** 105 to 125 (or 210 to 250) volts, 50 to 60 cps. Total power consumption is 90 watts.

Instrument will operate satisfactorily on power-supply frequencies up to 400 cps. Three-wire power cord.

**Accessories Supplied:** TYPE CAP-22 Power Cord, TYPE 274-NK Shielded Plug, spare fuses, and multipoint connector.

**Mounting:** Relay-rack panel easily adapted for table mounting by the addition of end frames (see below).

**Dimensions:** Width 19, height 7, depth 12 inches (485 by 180 by 305 mm), over-all.

**Net Weight:** 30 pounds (13.6 kg).

TYPE		CODE WORD	PRICE
1302-A	Oscillator.....	FINAL	\$500.00
FRI-412	Aluminum End Frames.....	ENDFRAMDIG	13.00 Pair





## TYPE 1304-B BEAT-FREQUENCY AUDIO GENERATOR

**USES:** For amplitude-frequency tests on audio frequency equipment — lines, amplifiers, filters, equalizers, transducers, and other networks — this beat-frequency generator is an excellent test-signal source. Its especial fitness for these applications lies in four of its characteristics:

- (1) its frequency scale is logarithmic;
- (2) it covers the entire audio range in one sweep of the dial;
- (3) its output voltage is constant with frequency;
- (4) its distortion is extremely low.

For automatic recording of rms level, the TYPE 1521-A Graphic Level Recorder will drive the oscillator dial through a chain-and-gear system. For use with an X-Y plotter, the TYPE 908-R Dial Drives are recommended.

As a general-purpose audio generator, the TYPE 1304-B finds constant use in the electronics laboratory, as a power source for bridge measurements, as a modulator for rf signal generators, and as a power source for acoustic tests at both audio and ultrasonic frequencies.

**DESCRIPTION:** This generator has a number of unusual design features that contribute to superior performance and ease of operation. Two radio-frequency oscillators, one fixed and one variable, feed a pentagrid converter through buffer amplifiers. The resulting difference frequency, after passing through a low-pass filter, is amplified in a degenerative amplifier. The output stage of this amplifier is the unique, low-distortion, single-ended, push-pull circuit.\*

\* A. P. G. Peterson and D. B. Sinclair, "A Single-Ended Push-Pull Audio Amplifier," Proc IRE, vol 40, pp 7-11, January, 1952.

The oscillator output level is continuously adjustable, and the output can be connected for either balanced or unbalanced use. The unbalanced output circuit contains a three-step attenuator. The output voltmeter is calibrated in dbm and open-circuit output volts.

The output voltmeter is used to standardize the frequency calibration of the oscillator when the output frequency is set to either the power-line frequency or to zero beat.

The frequency dial carries a logarithmic frequency scale for the range 20 cps to 20 kc, and it is driven by a slow-motion gear-reduction drive, essentially free from backlash.

Rotation is continuous, to facilitate automatic recording. A cycles-increment dial provides a means of varying the frequency over a range of  $\pm 50$  cycles at any setting of the main dial and can be swept by the TYPE 1750-A Sweep Drive.

A second range from 20 to 40 kc is available by the operation of a single panel switch.

### FEATURES:

- Essentially constant output voltage.
- Output voltmeter for accurate and rapid setting, and accurate attenuator.
- Frequency coverage from 20 cps to 40 kc. Linear frequency-increment dial.
- Audio spectrum — 20 cps to 20 kc covered in a single sweep of the dial.
- High stability of both output and frequency.
- Very low hum level.
- Excellent waveform.
- Dial can be motor driven.
- High-quality components, stabilized power supply, and advanced circuit design.





### SPECIFICATIONS

#### Frequency

**Range:** 20 cps to 40 kc in two ranges, 20 cps to 20 ke and 20 ke to 40 ke.

#### Frequency Calibration

**Controls:** Main dial has precision 10:1 reduction gear drive, and can be rotated continuously for automatic drive. Frequency increment dial is direct manual drive. Two-position switch changes frequency range.

**Calibration:** Main scale is logarithmic from 20 cps to 20 ke, covering a rotational angle of 240°, or 80° per decade. High-range position of switch adds 20 ke to main scale calibration. Frequency increment dial is linear, -50 to +50 cps.

**Accuracy:** Main dial,  $\pm(1\% + 0.5 \text{ cycle})$  after standardization by zero-beat setting or line-frequency. The 20-ke increment for the high range is accurate to  $\pm 0.5\%$ . Accuracy of frequency increment dial is  $\pm 1$  cps.

**Stability:** At zero beat, the drift from a cold start is less than 7 cps in the first hour and is essentially completed within two hours.

#### Output

**Voltage:** Continuously variable from below 5 millivolts to 50 volts, open circuit. Full-scale, open-circuit output voltages of 50 millivolts, 500 millivolts, 5 volts, and 50 volts are provided.

**Frequency Characteristic:** For a 600-ohm resistive load the variation of output voltage with frequency is as follows:

- NORMAL Range, 20 to 20,000 cps  $\pm 0.25$  db;
- ADD 20 KC Range, 20-30 ke,  $\pm 0.5$  db;
- 30-40 ke,  $\pm 1.0$  db.

For open-circuit operation, the output voltage rises considerably at the higher frequencies.

**Impedance:** 600 ohms, resistive, within  $\pm 2\%$ . At +20

dbm setting of the output attenuator, the output may be used either balanced or with one side grounded. With one side of the output grounded, the attenuator can be used throughout its entire range.

**Power:** 1 watt, max, into a 600-ohm resistive load.

**Distortion:** Less than 0.25% from 100 to 10,000 cps. Below 100 cps the harmonic content increases and may reach 0.5% at 50 cps. Above 10,000 cps the harmonic content is less than 1%.

**AC Hum:** Less than 0.1% of the output voltage for output voltmeter readings above 10% of full scale.

**Voltmeter:** Calibrated in volts output at open circuit, and in dbm. Above 10% of full scale, the calibration is accurate within  $\pm 5\%$  of the reading.

**Attenuator:** Used only with single-ended output; has three steps of 20 db each, with an accuracy of  $\pm 1\%$  of the nominal attenuation.

**Control:** For each step of the attenuator, the output voltage can be varied continuously from zero to the maximum voltage.

**Zero-Beat Indicator:** The output voltmeter is used to indicate zero beat.

#### Tube Complement:

- 2 - 6SL7-GT                    1 - 6SA7
- 2 - 6AV5-GA                 1 - 12AT7
- 2 - 0D3                        1 - 5V4-G

**Terminals:** TYPE 938 Binding Posts and standard Western Electric double output jack on panel; a standard four-terminal socket at the rear.

**Power Input:** 105 to 125 (or 210 to 250) volts, 50 to 60 cps. Power consumption is about 100 watts. Three-wire cord is supplied.

**Accessories Supplied:** TYPE CAP-22 Power Cord, four-terminal plug, and spare fuses.

**Mounting:** Aluminum 19-inch gray relay-rack panel; aluminum cabinet. See page 242 for description.

**Dimensions:** Width 19½, height 7¼, depth 15¼ inches (495 by 185 by 390 mm), over-all.

**Net Weight:** 39 pounds (18 kg).



Type 1304-B Generator driven by a Type 1521-A Graphic Level Recorder.



Type 1304-B Generator driven by a Type 908-R Dial Drive, for use with an X-Y plotter.

TYPE		CODE WORD	PRICE
1304-BM	Beat-Frequency Audio Generator, Bench Model	CAROL	\$680.00
1304-BR	Beat-Frequency Audio Generator, Relay Rack Model	CARGO	680.00

PATENT NOTICE. See Notes 5, 9 and 14, page viii.

Another Beat-Frequency Oscillator, the TYPE 1107-A, (page 74) has a linear scale from 0 to 5000 cps.





## TYPE 1210-C UNIT R-C OSCILLATOR

**USES:** This compact, inexpensive oscillator offers outstanding performance per dollar and per cubic inch of space.

It can be used as:

- A power source for sine-wave measurements at audio, ultrasonic, and low radio frequencies.
- A source of square waves for network steady-state and transient response measurements at audio, ultrasonic, and low radio frequencies.
- A sine-wave or square-wave modulator for rf oscillators and standard-signal generators.
- A square-wave trigger for pulse generators.
- A swept oscillator for displaying amplitude-frequency characteristics: with the TYPE 907-R144 Dial Drive for plotting the characteristics on a graphic recorder.
- A high-power RC oscillator when combined with the TYPE 1206-B Unit Amplifier.

**DESCRIPTION:** The frequency of the oscillator is determined by an RC network. A fast-response AVC system is used to hold the amplitude of oscillation constant in spite of changes in frequency or line voltage.

The oscillator provides three different outputs that contribute to its versatility and usefulness. A three-position switch selects any one of the following:

1. A low-impedance, low-voltage output from a cathode-follower type of amplifier.

This output has good waveform over its entire range of 0-7 volts. Distortion is less than 1% over most of the frequency range.

2. A high-impedance, high-voltage output from a cathode-follower-driven triode amplifier. Output impedance is constant, regardless of attenuator setting.

3. A square-wave output from a Schmitt circuit. This output furnishes square waves of 30-volt peak-to-peak amplitude (open-circuit) behind 2500 ohms, with  $\frac{1}{2}$   $\mu$ sec rise time and with approximately 1% overshoot.

The oscillator can be clamped to its external power supply to form a single, rigid unit, as shown above. Relay-rack adaptor panel is available.

### FEATURES:

- Very wide frequency range — audio, super-sonic, and radio frequencies.
- Sine- and square-wave output.
- Small size.
- Inexpensive.
- Sweeplable.
- Fast-responding AVC system.
- Calibrated output control.
- Output constant with frequency.
- High output voltage.
- Precision frequency-control dial.
- Compact and rugged.







### SPECIFICATIONS

#### Frequency

**Range:** 20-500,000 cps in five ranges: 20-200, 200-2000, 2000-20,000, 20,000-200,000, and 50,000-500,000 cps.

**Controls:** Range selection switch and 4-inch precision gear-driven dial. Dial has two scales, 2-20 and 50-500, and is geared to a slow-motion knob that covers each decade in about  $4\frac{1}{2}$  turns.

**Accuracy:**  $\pm 3\%$ .

**Stability:** Warm-up drift is less than 1%, essentially complete in 1 to 2 hours.

#### Output

**Control:** Logarithmic, calibrated 0-50 db.

**Low-Impedance:** (for loads of 500 ohms and higher) 0-7 v, open circuit, constant within  $\pm 1$  db up to 200 kc; internal output impedance 50 ohms at full output, 1250 ohms at half output; no-load distortion less than 1% from 200 cps to 10 kc, less than 1.5% over entire frequency range. Attenuator calibration is reliable for loads of 12,000 ohms and above. Hum is at least 60 db below output voltage level.

**High-Impedance:** (for loads of 10,000 ohms and higher) 0-45 v, open circuit, constant within  $\pm 1$  db from 200 cps to 150 kc; distortion less than 5% from 200 cps to 200 kc, no load (reduced under load). Internal output impedance 14,000 ohms regardless of attenuator setting. Hum at least 50 db below maximum output voltage level.

**Square Wave:** 0-30 v peak-to-peak, open circuit; rise time approximately  $\frac{1}{3}$   $\mu$ sec, (decreases to about 0.15  $\mu$ sec with load of 1000 ohms); overshoot approximately 1%; hum at least 60 db below output voltage level; internal output impedance 2500 ohms.

**Tube Complement:** One each 6BQ7-A, 0B2, 6189/12AU7-WA, 12AU7.

**Terminals:** Two jack-top TYPE 938 binding posts, one grounded to panel.

**Power Input:** 6.3 v ac or dc at 1 amp; 300 v dc at 60 ma.  
**Power Supply Recommended:** TYPE 1203-B Unit Power Supply for operation from 115 v, 50-60 cps.

The TYPE 1201-B Unit Regulated Power Supply will provide a slight improvement in frequency stability on the highest frequency range.

Instrument will operate satisfactorily on power-supply frequencies up to 400 cps, with either power supply.  
**Accessories Available:** For higher output (3 watts) use TYPE 1206-B Unit Amplifier (page 64); for graphic recording, TYPE 907-R144 Dial Drive (page 146).

**Mounting:** Gray finish; aluminum panel and chassis; bench mounting. The TYPE 480-P4U3 Relay Rack Adaptor Panel is available for use with oscillator and power supply combination. Panel height, 7 inches.

**Dimensions:** (Oscillator and Power Supply, as shown) width 15, height  $5\frac{3}{4}$ , depth 7 inches (380 by 145 by 175 mm) over-all.

**Net Weight:**  $5\frac{1}{2}$  pounds (2.5 kg).

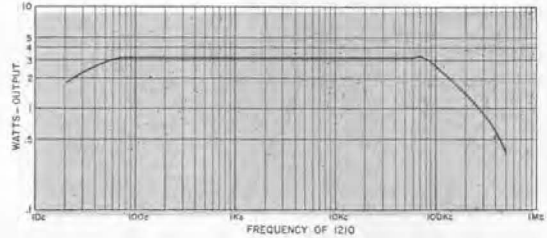

Output of the Type 1210-C Unit Oscillator with Type 1206-B Unit Amplifier, into 600-ohm load.

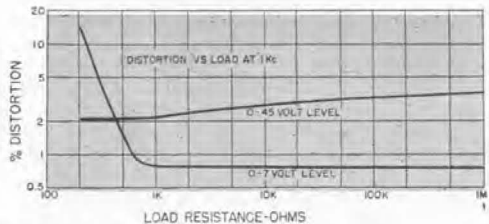
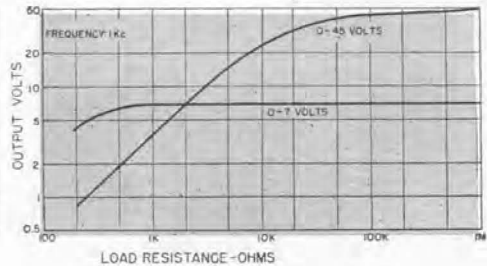
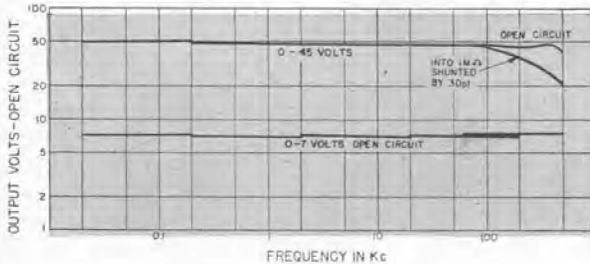

Typical output and harmonic distortion characteristics of the Type 1210-C Unit RC Oscillator as functions of frequency and load.

TYPE	CODE WORD	PRICE
1210-C	Unit R-C Oscillator.....	ABAF
1203-B	Unit Power Supply.....	ALIVE
1203-BQ18	Unit Power Supply, 210 to 250 volts.....	ALIVERALLY
480-P4U3	Relay-Rack Panel (for mounting both 1210-C and 1203-B in one panel).....	UNIPANCART
		\$180.00
		50.00
		60.00
		12.00





## TYPE 1300-A BEAT-FREQUENCY VIDEO GENERATOR

THREE MAJOR INSTRUMENTS IN A SINGLE PACKAGE

**USES:** The Beat-Frequency Video Generator provides four methods of circuit-response measurement at audio and video frequencies: point-to-point, square-wave, sweep-frequency for oscilloscope display, and automatic plotting with a graphic level recorder. Thus it has many applications, both in the laboratory and on the production line, in the testing of amplifiers, discriminators, filters, receivers, and, in general, any networks in the range from 20 cps to 12 Mc, and, to a limited extent, from 30 to 48 Mc. Examples of typical measurements are shown below.

**DESCRIPTION:** This generator includes five internal oscillators to obtain the frequency ranges shown in the block diagram and in the specifications, two pairs to generate the two beat-frequency ranges, and a fifth, or sweep,

oscillator, which replaces the high-frequency fixed oscillator for the video-sweep range. The frequency scale is logarithmic for the audio range and approximately logarithmic up to 5 Mc for the video range.

Buffer amplifiers are used between each oscillator and the pentagrid mixer to minimize coupling between the oscillators. The five-stage output amplifier uses high-transconductance tubes in a negative-feedback circuit to supply high output with low distortion and a flat frequency characteristic. A continuously adjustable level control is used at the amplifier input. The output attenuator has 10-db steps.

The square-wave generator is a Schmitt circuit driven from the output amplifier. A separate level control provides continuous adjustment of the output amplitude.

For narrow-band measurements, the frequency-increment dials can be swept by the TYPE 1750-A Sweep Drive. For X-Y plotting, a TYPE 908-R Dial Drive can be used.

### FEATURES:

- Replaces three major instruments: beat oscillator, sweep oscillator, and square-wave generator.
- Either range, audio or video, is spanned by a single rotation of the dial.
- High resolution at any frequency is provided by the incremental frequency dials.
- High output voltage, low distortion, excellent stability.
- Additional outputs in the 30-to-48-Mc range permit i-f circuit testing.

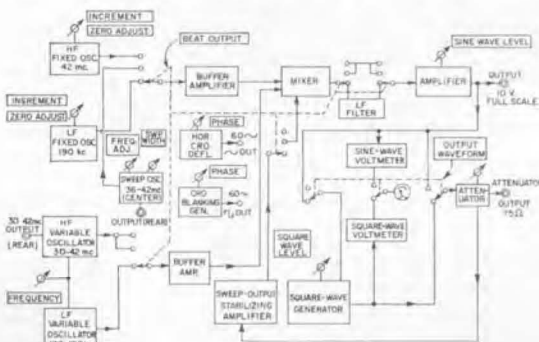

Block diagram of the Type 1300-A Beat-Frequency Video Generator.



### SPECIFICATIONS

OUTPUT: FREQUENCY RANGE	SIGNAL	OPEN-CIRCUIT AMPLITUDE	TOLERANCE	IMPEDANCE
20-20,000 cps	Sine Wave	0-10 v	< ±0.25 db	820 Ω
20-20,000 cps	Sine Wave	0-1 v	< ±0.25 db 40 cps-20 kc	75 Ω ±2% (Attenuator)
20-20,000 cps	Square Wave	0-10 v p-to-p (0-2.5 v p-to-p across 75 Ω)	< ±0.75 db at 20 cps	75 Ω ±2% (Attenuator)
20 kc-12 Mc	Sine Wave	0-10 v	±1 db	820 Ω
20 kc-12 Mc	Sine Wave	0-1 v	±1 db	75 Ω ±2% (Attenuator)
20 kc-12 Mc	Square Wave	0-10 v p-to-p (0-2.5 v p-to-p across 75 Ω)	±0.5 db	75 Ω ±2% (Attenuator)
20 kc-12 Mc Center Freq. 0-±6 Mc Sweep	Sine-Wave Sweep*	0-10 v	±1 db (up to 12 Mc)	820 Ω
20 kc-12 Mc Center Freq. 0-±6 Mc Sweep	Sine-Wave Sweep*	0-1 v	±1 db (up to 12 Mc)	75 Ω ±2% (Attenuator)
30-42 Mc	Sine Wave	Approx 50 mv	±1 db**	Approx 50 Ω
36-42 Mc Center Freq. 0-±6 Mc Sweep	Sine-Wave Sweep*	Approx 100 mv	±2 db**	50 Ω or higher load recommended

\*Sweep rate is at power-line frequency.

\*\* Typical, not guaranteed.

#### Frequency

**Controls and Calibration:** Main dial, inner scale, 20 cps to 20 kc, logarithmic, 80° per decade, scale length approximately 10 inches; outer scale, 20 kc to 12 Mc, approximately logarithmic up to 5 Mc, approaching linear distribution at high end, scale length approximately 12 inches.

Frequency increment dials, audio, -50 to +50 cps; video, -20 to +20 kc.

**Accuracy:** Audio range, ±(1% + 1 cps) after zero-beat setting; video range, ±(1% + 1 kc) from 500 kc to 12 Mc, ±(2% + 1 kc) below 500 kc, after zero-beat setting. Frequency increment dials, audio, ±1 cps; video, ±0.5 kc. The frequency-increment dial does not operate on the video-sweep range.

#### Stability

**Audio Range:** The drift from a cold start is less than 20 cps in two hours.

**Video Range:** The drift from a cold start is less than 20 kilocycles in two hours.

**Zero-Beat Indicator:** The output voltmeter is used to indicate zero beat.

**Output:** See table above.

**Voltmeter:** The panel meter indicates rms sine-wave voltage to ±3% and peak-to-peak square-wave voltage to ±5%. Auxiliary scale indicates 0- to 20-db value below full scale. The sine-wave voltmeter is connected in series with a 10-μf capacitor to the 10-volt output jack.

**Attenuator:** 75 ohms in eight steps of 10 db each, with an accuracy of ±1% of nominal. Sine-wave, full-scale, open-circuit voltages are 0.1 mv, 0.3 mv, 1 mv, 3 mv, 10 mv, 30 mv, 0.1 v, 0.3 v, and 1 v. Square-wave, full-scale, open-circuit voltages are 1 mv, 3 mv, 10 mv, 30 mv, 100 mv, 300 mv, 1 v, 3 v, and 10 v.

**Horizontal Deflection Voltage:** 4 volts at 60 cps (or power-line frequency) for horizontal deflection of a cathode-ray oscilloscope. Since both this voltage and the frequency distribution of the sweep output vary sinusoidally, the oscilloscope pattern is approximately linear. A blanking voltage (50-volt, peak-to-peak,

square-wave) is also supplied.

**Square-Wave Characteristics:** At 60 cps, ramp-off is less than 2% of the peak-to-peak amplitude; at 20 cps, less than 5%. Rise time for frequencies from 300 kc to 2 Mc is less than 75 nanoseconds. At 20 kc the rise time is approximately 150 nanoseconds. Over-shoot is about 10% of the peak-to-peak output voltage.

**Harmonic Distortion:** Sine-wave output, less than 1% of output on the 20 cps-20kc range and less than 4% of output on the VIDEO SWEEP and 20 kc-12 Mc ranges.

**AC Hum:** Less than 0.1% of the output for voltmeter readings above 10% of full scale.

**Terminals:** Type 874 Coaxial Terminals are provided for all outputs.

#### Tube Complement:

1 — 0B2	2 — 6AQ6	1 — 6BK7-B
1 — 5651	1 — 6AV6	1 — 6BQ5
1 — 6080	1 — 6BA7	1 — 6J6
2 — 6197	1 — 6BC4	4 — 12AX7
4 — 6AB4		

**Power Input:** 105 to 125 (or 210 to 250) volts, 50 to 60 cps. Power input at 117 volts is approximately 175 watts, maximum. Instrument will operate normally, except for sweep output, at supply frequencies up to 400 cps. Three-wire power cord.

**Accessories Supplied:** One TYPE CAP-22 Power Cord; two TYPE 874-R22 50-ohm Patch Cords; one TYPE 874-413 75-ohm Patch Cord; one TYPE 874-Q2 Adaptor, three TYPE 874-C58 Cable Connectors, and spare fuses.

**Other Accessories Available:** TYPE 1521-A Graphic Level Recorder for automatic recording at audio frequencies; TYPE 1750-A Sweep Drive for slow-speed sweeping; TYPE 908-R Dial Drive for X-Y plots; TYPE 1213-D Unit Time/Frequency Calibrator for timing markers.

**Mounting:** Aluminum, 19-inch, gray, relay-rack panel; aluminum relay-rack type cabinet. See page 242 for description.

**Dimensions:** Width 19, height 15¼, depth 14½ inches (485 by 400 by 370 mm) over-all.

**Net Weight:** 64 pounds (29 kg).

TYPE	CODE WORD	PRICE
1300-AM	ANGEL	\$1950.00
1300-AR	ASPEN	1950.00

PATENT NOTICE. See Note 4, page viii.





## TYPE 1214 UNIT OSCILLATORS



The TYPE 1214 Unit Oscillators are compact and inexpensive oscillators generating fixed frequencies. A TYPE 1214 Unit Oscillator is a convenient modulator for the high-frequency Unit Oscillators and a power source for bridge measurements. The output can be isolated from ground for use of the oscillator as a modulator in the plate circuit of a high-frequency oscillator. Power supply is built in. The TYPE 1214-D includes an impedance-matching transformer (8000 to 1, 10, 100, or 1000 ohms) which can be used with an external oscillator, as well.



### SPECIFICATIONS

TYPE	1214-A	1214-D	1214-M
Frequency	400 or 1000 cps	120 cps	1 Mc
Accuracy	±2%	±5%	±1%
*Maximum Output	200 mw into 8000 ohms	400 mw into 1, 10, 100, 1000 ohms	300 mw into 50 ohms
Distortion	3% into 8000 ohms	3% into matched load	3.5% into 50 ohms
*Open-Circuit Output Voltage	0 to 60 v	45, 13, 4.5, or 1.3 v	0 to 7 v
Power Input at 115 Volts	16 w	16 w	12 w
Net Weight	4½ pounds (2.1 kg)	4½ pounds (2.1 kg)	2¾ pounds (1.3 kg)
Tube	One 117N7-GT, which is supplied with the instrument		
Dimensions	Panel width 4¾, height 5¼, depth 6 inches (120 by 135 by 155 mm)		

\* Output voltage changes by about 12% per 10% change in line voltage. Power and voltage values given are for 115-volt input.

**Power Supply:** 105 to 125 volts, 50 to 60 cps. Instrument will operate satisfactorily on power-supply frequencies up to 400 cps. Three-wire power cord.

**Accessories Supplied:** Spare fuses.

**Mounting:** Aluminum cabinet and dust cover. Relay-rack panel available.

TYPE		CODE WORD	PRICE
1214-A	Unit Oscillator, 400 and 1000 cps.....	ALLAY	\$75.00
1214-D	Unit Oscillator, 120 cps.....	ABBOT	100.00
1214-M	Unit Oscillator, 1 Mc.....	ATONE	75.00
480-P4U1	Relay-Rack Adaptor Panel (for one oscillator).	UNIPANARCH	11.00

## TYPE 1307-A TRANSISTOR OSCILLATOR

In addition to its use as a power source for the TYPE 1552-B Sound-Level Calibrator, this pocket-size oscillator is convenient for use in continuity checks of audio systems, in setting operating levels, in checking sensitivity of oscillographs, in making preliminary calibrations of electronic systems, and as a power source for bridge measurements at 400 and 1000 cps.

**DESCRIPTION:** The oscillator uses a P-N-P junction transistor in a Hartley circuit. An output control is provided, and a rectifier-type voltmeter indicates output voltage.





### SPECIFICATIONS

**Frequency:** 400 and 1000 cps.  
**Frequency Accuracy:**  $\pm 3\%$  at 2 volts output into 600-ohm resistive load.  
**Output:** Adjustable to a maximum of at least 2 volts into a 600-ohm load.  
**Distortion:** Less than 5% at 400 cps and less than 6% at 1000 cps with 2 volts across a resistive 600-ohm load.  
**Voltmeter:** Calibrated in volts, with 3 volts full scale.  
**Output Circuit:** Output cable (20 inches) terminated in a TYPE 274-MB Double Plug.  
**Batteries:** Three mercury A batteries (Mallory RM-1 or

equivalent) are supplied. Battery life is about 100 hours for 8 hours use per day.

**Transistor:** One P-N-P junction transistor (RCA Type 2N105 or equivalent).

**Mounting:** Gray aluminum panel and case.

**Carrying Case:** Leather case with a strap is available for holding both oscillator and sound-level calibrator.

**Dimensions:** Width  $3\frac{1}{8}$ , height 6, depth  $2\frac{1}{2}$  inches (79 by 153 by 64 mm) over-all.

**Net Weight:**  $1\frac{3}{4}$  pounds, (0.8 kg) with batteries.

TYPE		CODE WORD	PRICE
1307-A	Transistor Oscillator.....	OMEGA	\$97.00

PATENT NOTICE: See Note 1, page viii.

## TYPE 1211-B UNIT OSCILLATOR

**USES:** The wide frequency range and high power output of the TYPE 1211-B Unit Oscillator make it a most useful general purpose, radio-frequency generator. It is well-shielded, has excellent frequency stability, and can be amplitude-modulated from an external source. It is recommended for driving the TYPES 916-AL and 1606-A RF Bridges.

**DESCRIPTION:** The 100:1 frequency span of 0.5 to 50 Mc is achieved in two bands by simultaneous variation of the capacitance and inductance of the tuned circuit.

### FEATURES:

➤ Compact unit design.



- Two ranges, 0.5 to 5 Mc and 5 to 50 Mc.
- Logarithmic frequency scale.
- Power output of at least 200 milliwatts.
- Can be externally amplitude modulated.

### SPECIFICATIONS

#### Frequency

**Range:** 0.5 to 50 Mc in two ranges.

**Calibration Accuracy:**  $\pm 2\%$  at no load.

**Controls:** A two-position range switch, a six-inch precision dial with calibration approximately logarithmic vs angular rotation, and a vernier dial to indicate frequency increments of 0.2% per dial division.

#### Output

**System:** Coaxial connector at rear of instrument. An adjacent ground terminal also permits connection by means of a TYPE 274-M Plug. The output control is at the rear and carries a dial with arbitrary scale.

**Power:** With TYPE 1203-B Unit Power Supply, at least 200 milliwatts into a 50-ohm load at any frequency. Over the 0.5-5 Mc range, the average output is approximately 2 watts; for the 5-50 Mc range, it is 0.7 watts.

**Modulation:** Direct sine-wave amplitude modulation over the audio range can be obtained with an external audio oscillator. 45 volts into 8000 ohms will produce

approximately 25% modulation. Envelope distortion is of the order of 3% and is a function of carrier-frequency setting. The audio source must be capable of carrying the 50-ma direct plate current of the carrier oscillator. For amplitude modulation free from incidental fm, a TYPE 1000-P6 Crystal Diode Modulator can be used at carrier frequencies above 10 Mc.

**Power Supply Requirements:** 300 volts at 50 ma, dc; 6.0 volts at 0.75 amperes, ac or dc.

**Power Supply Recommended:** For maximum output, TYPE 1203-B Unit Power Supply; for best stability, TYPE 1201-B Unit Regulated Power Supply; for constant output level vs frequency, TYPE 1263 Amplitude-Regulating Power Supply.

**Tube:** One TYPE 5763 miniature beam-power amplifier.

**Mounting:** The oscillator is mounted on an aluminum casting, shielded with a spun aluminum cover. The assembly is mounted on an L-shaped panel and chassis. The panel finish is gray crackle lacquer.

**Accessories Supplied:** TYPE S74-R22 Patch cord, TYPE S74-Q2 Adaptor, and Telephone Plug.

**Dimensions:** Width 7, height 8, depth 12 inches (180 by 205 by 305 mm), over-all.

**Weight:**  $11\frac{1}{2}$  pounds (5.3 kg).

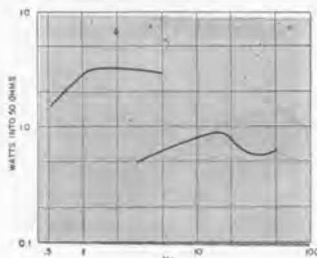

Typical output vs. frequency curve for the Type 1211-B Unit Oscillator.

TYPE		CODE WORD	PRICE
1211-B	Unit Oscillator (0.5-50 Mc)	ATLAS	\$295.00
1203-B	Unit Power Supply	ALIVE	50.00
480-P5UC1	Relay-Rack Panel (for oscillator and power supply)	UNIPAN-GOLF	15.00

PATENT NOTICE: See Note 4, page viii.





## TYPE 1330-A BRIDGE OSCILLATOR

**USES:** The TYPE 1330-A Bridge Oscillator is an economical, general-purpose, laboratory source, of maximum utility and adaptability. It covers the frequency range of the TYPE 1606-A and TYPE 916-AL Radio-Frequency Bridges and the TYPE 716-CS1 Capacitance Bridge. At audio frequencies it can be used with the TYPE 716-C Capacitance Bridge, the TYPE 1603-A Z-Y Bridge, the TYPE 1632-A Inductance Bridge, and the TYPE 1661-A Vacuum-Tube Bridge. Its power output of about one watt is adequate for most resonant-circuit measurements.

**DESCRIPTION:** The circuit and the mechanical construction of the Bridge Oscillator are similar to those used in the TYPE 1001-A Standard-Signal Generator (page 86), but a higher-power oscillator tube is used, and the aperiodic output stage has been omitted. Tuning capaci-

tor and inductors are ruggedly constructed to assure frequency stability, the oscillator circuits are doubly shielded to minimize stray fields, and a modulating circuit of unusual design provides excellent modulation characteristics over the radio-frequency range.

Modulation is available at two audio frequencies and at two levels, selected by switches.

### FEATURES:

- > Wide frequency range.
- > Internal modulation available.
- > Good frequency stability.
- > Excellent shielding.
- > One watt output over much of the radio-frequency range.
- > Rugged and compact construction.
- > Good band spread on all ranges.

### SPECIFICATIONS

#### Frequency

**Range:** Three fixed frequencies — 1000 cps, 400 cps, and the power-line frequency; 5 kc to 50 Mc, continuous.

**Calibration:** Direct-reading for eight 3:1 ranges. Calibration is logarithmic and vernier dial indicates increments of 0.1% per division from 5 ke to 15 Me.

**Accuracy:** 400 and 1000 cps,  $\pm 5\%$ ; frequencies below 150 kc,  $\pm 3\%$ ; above 150 kc,  $\pm 2\%$ , all at no load. Frequency shift with 50-ohm load, 5% at low carrier frequencies; above 150 kc, less than 1%.

#### Output

**Voltage:** Open-circuit audio, 12 volts; rf, adjustable, approximately 10 volts over the mid-frequency range, less at ends of range.

**Power:** Into 50-ohm load, audio, approximately  $\frac{3}{4}$  watt; rf, 1 watt, maximum.

**Impedance:** Audio jack, 50 ohms; rf 20 to 80 ohms depending upon frequency, when output control is at maximum setting.

**RF Distortion:** With maximum output into 50 ohms, about 3.5%, except at the lower frequencies, where it is 7%.

**Audio Distortion:** 5%.

**Leakage:** Stray fields are less than 50  $\mu$ v per meter at two feet from the oscillator.

**Modulation:** Internal only, at 400 and 1000 cps, 25% and 50%.

**Envelope Distortion:** Less than 6% at 50% modulation; less than 4% at 25% modulation.

**Power Input:** 105 to 125 (or 210 to 250) volts, 50 to 60 cps; 30 watts, approximately.

**Tube Complement:** Two 6AQ5, one 6X4.

**Accessories Supplied:** TYPE 874-R22 Coaxial Cable, TYPE 874-Q2 Adaptor, TYPE 874-C58 Cable Connector, TYPE TO-44 Adjustment Tool (mounted on rf shield cover), TYPE CAP-22 Power Cord, and spare fuses.

**Mounting:** Aluminum panel, finished in gray crackle; aluminum cabinet in gray wrinkle. Cabinet removes for rack mounting.

**Terminals:** TYPE 874 Coaxial Connectors.

**Dimensions:** Width 21 $\frac{3}{4}$ , height 7 $\frac{1}{2}$ , depth 11 $\frac{1}{4}$  inches (555 by 190 by 285 mm), over-all.

**Net Weight:** 37 $\frac{1}{2}$  pounds (17 kg).

TYPE	CODE WORD	PRICE
1330-A   Bridge Oscillator	ACORN	\$635.00

PATENT NOTICE. See Note 4, page viii.





### TYPE 1361-A UHF OSCILLATOR

**USES:** This high-quality oscillator is a calibrated, stable power source for measurement and testing at frequencies between 450 and 1050 Mc. Its 100-milliwatt output is adequate for driving the TYPE 874-LBA Slotted Line, the TYPE 1602-B UHF Admittance Meter, and the TYPE 1607-A Transfer-Function and Immittance Bridge, as well as the TYPE 874-MR Mixer Rectifier in heterodyne detector systems.

With the TYPE 1750-A Sweep Drive or the TYPE 907-R144 Dial Drive, the output frequency can be swept mechanically for oscillographic display or recording. External power supplies are available to maintain constant amplitude and for amplitude modulation by sine waves, square waves, or pulses.

Frequency is determined by a General Radio butterfly circuit (no sliding contacts) and is controlled by a 4-inch precision dial calibrated to  $\pm 1\%$ . Each full turn of the vernier dial corresponds to a numbered sector on the main dial, so that settings can be recorded and repeated in terms of sector number and vernier divisions.

A wave-guide-below-cutoff attenuator, calibrated in relative attenuation, is located on the front panel. The output coupling loop slides in and out for output adjustment and can be locked at any point. The output terminal is a locking TYPE 874 Coaxial Connector which permits semi-permanent installation of adaptors to military-type connectors.

The radiated and conducted fields have been reduced to a very low value by complete shielding, and by the use of ferrite-loaded filters and a ceramic rotor shaft.

Housed in a rack-bench cabinet, the oscillator can be attached to the Modulating Power Supply or the Amplitude-Regulating Power Supply to form a single, rigid unit. Panel extensions are available for rack mounting.

#### FEATURES:

- Butterfly tuned circuit.
- Precision drive.
- Logarithmic scale.
- Calibrated attenuator.
- Bench or rack mounting.

(Left) Typical pulse performance curves for the Type 1361-A UHF Oscillator with the Type 1264-A Power Supply. (Below) Typical curves of output vs. frequency for the Type 1361-A UHF Oscillator.

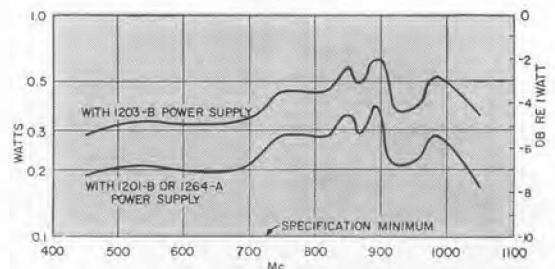
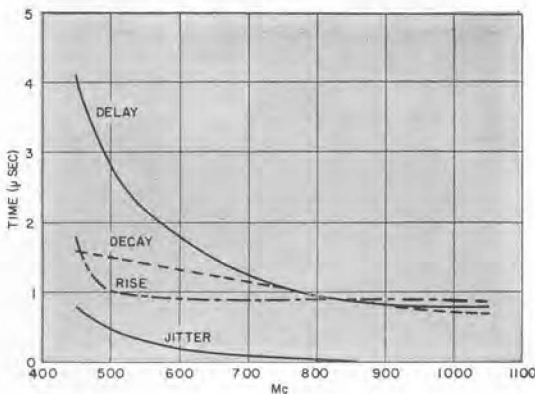

# OSCILLATORS

VHF, UHF



## SPECIFICATIONS

### Frequency

Range: 450 to 1050 Mc.

Calibration: Logarithmic frequency scale; vernier dial calibrated in 0.1% increments.

Accuracy:  $\pm 1\%$ .



Oscillator with Modulating Power Supply and Panel Extensions for relay-rack mounting.

POWER SUPPLY TYPE	OSCILLATOR MODULATION POSSIBILITIES <sup>1</sup>	OSCILLATOR OUTPUT <sup>2</sup> INTO	REMARKS
		50 OHMS	
1203-B <sup>3</sup>	Sine Wave	125 mw	Gives max rf output.
1201-B <sup>3</sup>	Sine Wave	100 mw	Gives max freq. stability.
1263-B	1-kc-square wave	20 mw	Holds oscillator output constant with frequency.
1264-A <sup>3</sup>	Sine, pulse, and square wave	100 mw	
1216-A	Sine wave	Adequate for heterodyning.	

<sup>1</sup> Sine-wave modulation depth is 30% with 40 volts into 6000 ohms. Type 1214-A Unit Oscillator is recommended.

<sup>2</sup> At least as great as stated.

<sup>3</sup> Will operate from 400-cycle line.

**Stability:** Warm-up frequency drift is 0.2%, maximum.  
**Attenuator:** Range, 80 db with 5-db scale divisions, relative attenuation. Additional uncalibrated range is provided.

**Power Supply:** Five types of power supplies are available, each designed for a particular purpose.

**Tube:** One 5675, supplied.

**Accessories Supplied:** Type 874-R22 patch cord, Type 874-C58 Cable Connector, and telephone plug.

**Other Accessories Available:** Panel extensions for rack mount (see below), Type 874 Coaxial Elements to fit output connector, adaptors to military connectors (see pages 38-55).

**Cabinet Dimensions:** Width 8, height 7 $\frac{1}{2}$ , depth 9 $\frac{1}{2}$  inches (205 by 195 by 240 mm) over-all.

**Net Weight:** 7 pounds (3.2 kg).

TYPE		CODE WORD	PRICE
1361-A*	UHF Oscillator	OLIVE	\$285.00
480-P408	Panel Extensions (pair, for oscillator only)	EXPANELJAG	8.00 Pair
480-P416	Panel Extensions (pair, for oscillator and Type 1263-B or Type 1264-A Power Supply)	EXPANELNIT	6.00 Pair

\*PATENT NOTICE. See Notes 4 and 10, page viii.

## VHF AND UHF UNIT OSCILLATORS

**USES:** These oscillators are compact, low-priced units that cover wide frequency ranges with single-dial control. Adequate power, coupled with good shielding, makes these oscillators well suited to drive bridges, slotted lines, and other impedance-measuring equipment. Their convenient adaptability makes them useful as general-purpose instruments for the laboratory, and their small size, simplicity, and low cost assure their usefulness in production applications. They are widely used as built-in power sources in special-purpose assemblies; the TYPE 1218-A, for example, in parametric amplifiers, as a stable, adjustable, low-noise source of pump frequency.

General Radio Unit Oscillators cover all frequencies between 20 cps and 2000 Mc, and, barring a few small gaps, all frequencies from 2700 to 7425 Mc.

**ASSEMBLIES:** These oscillators can be used with TYPE 874 Coaxial Elements to assemble a wide variety of systems, such as detectors, signal generators, pulsed oscillators, etc., which would otherwise require more specialized and expensive equipment.

The diagram on page 111 shows some of the accessories used with Unit Oscillators for building-block assemblies. For more complete listing of accessories see:

Unit Oscillator with Unit Power Supply in Relay-Rack Adaptor Panel.



Coaxial Elements	pp 43-51
Connectors and Adaptors	pp 40-42
Dial Drives	pp 144-146
Modulators	pp 92-93
Power Supplies	pp 136-140
Sweep Drives	pp 144-146





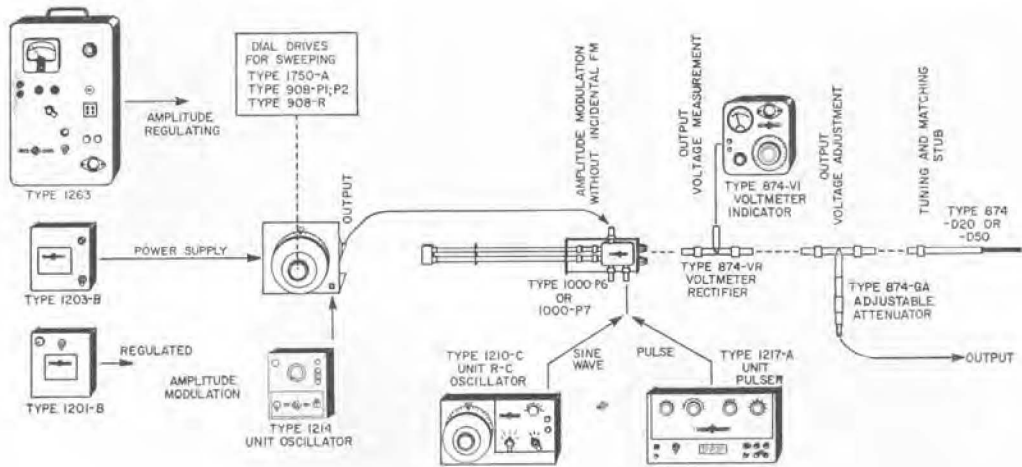

### GENERAL SPECIFICATIONS

(See following pages for individual oscillator specifications)

**Frequency Control:** 6-inch precision dial with vernier drive for TYPES 1215-B and 1218-A; 4-inch precision dial with vernier drive for TYPES 1208-B, 1209-B, and 1209-BL.

**Output Power:** Output power listed is obtainable at any frequency within the range of the oscillator when the TYPE 1203-B Unit Power Supply is used. With the TYPE 1201-B Unit Regulated Power Supply, the TYPE 1263-B Amplitude-Regulating Power Supply, or the TYPE 1264-A Modulating Power Supply, output is approximately 0.6 of the power listed; with the TYPE 1216-A Unit I-F Amplifier, it is about 0.4. Output of all Unit Oscillators varies with frequency as shown in the individual curves. This variation can be eliminated by using the TYPE 1263-B Amplitude-Regulating Power Supply; the maximum output voltage obtainable is then limited to 2 volts.

The output power of Unit Oscillators is adequate for practically all laboratory measurements with bridges, slotted lines, admittance meters, tuned circuits, etc.

**Output System:** Short coaxial line with adjustable coupling loop at one end, and a TYPE 874 Coaxial Connector on the other. Maximum power can be delivered to load impedances normally encountered in coaxial systems.

**Terminals:** Output terminals are TYPE 874 Coaxial Connectors for convenient connection to General Radio measuring equipment and coaxial elements. Adaptors are available to other standard coaxial connectors (see page 42), making these oscillators compatible with practically all coaxial systems.

**Power Supply:** Unit Oscillators are designed to operate from the inexpensive TYPE 1203-B Unit Power Supply. With the TYPE 1201-B Unit Regulated Power Supply, better stability against line voltage variations is obtained. The TYPE 1263-B Amplitude-Regulating Power Supply is available for constant output vs. frequency and the TYPE 1264-A Modulating Power Supply for square-wave and pulse modulation. Other power sources meeting the necessary voltage and current specifications (see page 112) can also be used.

**400-Cycle Power Supply:** All Unit Oscillators, except the TYPE 1208-B, can be operated from 400-cycle supply with Unit Power Supplies.

**Modulation:** Amplitude modulation over the audio range can be obtained by superimposing a modulating voltage on the plate supply. The audio source must be capable of carrying the dc plate current of the oscillator. The TYPE 1214 Oscillators are recommended as modulators. Incidental fm inherent in this system is of the order of .01% for 30% am in the lower part of the tuning range and increases rapidly at the high-frequency end.

For 30% amplitude modulation, 40 volts across 8000 ohms is adequate. The TYPE 1218-A can be square-wave modulated at 100 to 5000 cps from a 2500-ohm source supplying 30 volts, peak to peak. Either the TYPE 1210-C Unit Oscillator or the TYPE 1217-A Unit Pulser is recommended. Both pulse and square-wave modulation are possible with any of these oscillators if the TYPE 1264-A Modulating Power Supply is used.

With the TYPE 1000-P7 Balanced Modulator, the output of the Unit Oscillators (above 60 Mc) can be modulated up to 100% with sinusoidal or pulse waveforms, and rise times as short as .02  $\mu$ sec can be obtained. For video modulation the TYPE 1000-P6 Crystal Diode Modulator can be used. Maximum output is about 10 millivolts with these modulators.

**Sweep Applications:** Adaptability to sweeping techniques is another convenience of these instruments. TYPES 1209-B, 1209-BL, and 1215-B are equipped with ball bearings and use butterfly circuits, which have no sliding contacts. They can be swept mechanically at moderate speeds by the TYPE 1750-A Sweep Drive for oscilloscopic display, or at slow speeds by the TYPES 907-R and 908-R Dial Drives for X-Y reading.

The TYPES 1208-B and 1218-A have sliding contacts in their tuned circuits and are not recommended for use with the TYPE 1750-A Sweep Drive, but they can be driven for short periods by the TYPE 908-R Dial Drive. For sweep applications, the TYPE 1263-B Amplitude-Regulating Power Supply is recommended, to hold the output constant as the frequency is varied.

**Accessories Supplied:** TYPE 874-R22 Patch Cord, TYPE 874-C58 Cable Connector and Telephone Plug.

**Mounting:** Oscillator is mounted in an aluminum casting, and is shielded with a spun-aluminum cover. The assembly is mounted on a gray L-shaped panel and chassis. Relay-rack adaptor panels are available.

# OSCILLATORS

VHF, UHF



TYPE 1215-B



TYPE 1209-BL



TYPE 1218-A



TYPE 1208-B



TYPE 1209-B

Type No.	1215-B	1208-B	1209-BL	1209-B	1218-A
Frequency	50-250 Mc	65-500 Mc	180-600 Mc	250-960 Mc	900-2000 Mc
Tuned Circuit	Semi-butterfly with no sliding contacts	Sliding contact	Butterfly, with no sliding contacts	Butterfly, with no sliding contacts	Line sections with sliding contacts
Frequency Calibration Accuracy	±1% at no load	±2%	±1%	±1%	±1%
Warm-Up Frequency Drift	0.4%	0.5%	0.2%	0.2%	0.1%
Output into 50 Ω	80 mw	100 mw	300 mw	200 mw	200 mw
Typical Output Characteristic					
Power Supply Required	350 v, 25 ma, 6.3 v, 0.3 amp	320 v, 40 ma, 6.3 v, 0.9 amp	320 v, 36 ma, 6.3 v, 0.4 amp	325 v, 40 ma, 6.3 v, 0.4 amp	340 v, 30 ma, 6.3 v, 0.3 amp
Tube	12A7 Miniature Twin-Triode	2C43 Lighthouse Triode	6481 Disc Seal Triode	6481 Disc Seal Triode	5675 UHF Medium-mu Pencil Triode
Dimensions Inches mm	7 × 8 × 9½ 180 × 205 × 240	6¼ × 6¼ × 8¼ 160 × 160 × 210	7 × 6¼ × 9¼ 180 × 160 × 235	7 × 6¼ × 9¼ 180 × 160 × 235	12½ × 10½ × 9½ 320 × 270 × 240
Net Wt lb kg	7½ 3.4	5½ 2.5	6¼ 2.9	6¼ 2.9	14¾ 6.7
Code Word	ADOPT	AMEND	ADMIT	AMISS	CARRY
Price	\$210.00	\$230.00	\$260.00	\$260.00	\$465.00

See also General Specifications.

## RELAY-RACK ADAPTOR PANELS

For Oscillator Only					480-P7U1 Height 12¼"
For Osc and 1203 or 1201 Power Supply	480-P5UC1 Height 8¾"	480-P4UC1 Height 7"	480-P4UC2 Height 7"	480-P4UC2 Height 7"	
Code Word	UNIPANGOLF	UNIPANDOCK	UNIPANFORT	UNIPANFORT	UNIPANHUMP
Price	\$15.00	\$13.00	\$13.00	\$13.00	\$15.00

PATENT NOTICE. See Notes 4 and 10, page viii





# OSCILLATORS

## MICROWAVE



### TYPE 1220-A UNIT KLYSTRON OSCILLATOR KLYSTRON POWER SUPPLY

**USES:** The Unit Klystron Oscillator generates frequencies between 2700 and 7400 megacycles. It can generate fixed frequencies or swept frequencies and can be amplitude modulated with either square waves or pulses, with very low incidental fm.

Because of its relatively high output, low cost, small size and rugged construction, it is equally useful in the laboratory, on the production line, and in classroom demonstrations. It is an excellent source for slotted-line measurements of impedance and VSWR, measurements of bandwidth, and attenuation measurements on cables, lines, and pads.

**DESCRIPTION:** This instrument includes an adjustable, regulated source of repeller voltage, a Schmitt squaring circuit, a 1000-cycle RC oscillator, and a socket for a reflex klystron tube. Klystron cathode current is furnished by an external Unit Power Supply (shown in photo).

Eight plug-in klystrons cover the frequency range. The oscillator is listed with each single klystron; additional klystrons can be ordered as desired.

Klystron frequency can be adjusted by a screw adjustment at the rear.

### SPECIFICATIONS

**Frequency Range:** Depends on klystron tube used (see table below); frequency range of any unit can be changed to that of any other by inserting the appropriate klystron tube.

**Amplitude Modulation:**

*Internal:* 1-ke square wave, adjustable  $\pm 15$  cps.

*External:* Square wave: 50 cps to 200 kc; sine or square-wave modulating signal of at least 15 v rms required — TYPE 1210-C RC Oscillator recommended.

*Pulse:* 1 to 10,000  $\mu$ sec duration, less than 0.2  $\mu$ sec rise and fall time, 50 cps to 200 kc repetition rate; at least 20v peak pulse voltage required — TYPE 1217-A Unit Pulser recommended.

**Frequency Modulation:** At least 15-Mc excursion obtainable with less than 3 db change in output at 60 cps, an rms input of the order of 10 v is suitable.

**Output Connector:** 50-ohm TYPE 874 Coaxial Connector. Adaptors to other connector types available. (See page 42).

**Tube Complement:** Klystron, as specified, for TYPES 1220-A1 through A8; one 6AB4, one 5963, two 0A2.

**Power Input:** TYPE 1201-B Unit Regulated Power Supply is recommended for high stability and minimum incidental fm (page 137); with this power supply the oscillator can be operated from a 400-cycle source provided that the line voltage is between 115 and 125 volts.

**Accessories Recommended:** Fixed attenuator pad for isolating oscillator from load (page 48); TYPE 874-VQ or-VR for facilitating tuning adjustments (page 50).

**Dimensions:** Width 15, height 5 $\frac{3}{4}$ , depth 6 $\frac{1}{4}$  inches (380 by 145 by 160 mm) over-all, including power supply as shown above.

**Net Weight:** 6 pounds (2.8 kg), with klystron, (less power supply).

TYPE	KLYSTRON OSCILLATOR WITH KLYSTRON, FOR	NOMINAL OUTPUT IN MILLIWATTS	CODE WORD	PRICE	TUBE ONLY TYPE	CODE WORD	PRICE
1220-A1	2700-2960 Mc	100	KAWUN	\$288.00	726-C	KLYSTRONAY	\$53.00
1220-A2	2950-3275 Mc	90	KATOO	303.00	6043	KLYSTROBEE	68.00
1220-A3	3400-3960 Mc	90	KATRE	288.00	2K29	KLYSTROSEE	53.00
1220-A4	3840-4460 Mc	75	KAFOR	337.00	2K56	KLYSTRODEE	102.00
1220-A5	4240-4910 Mc	100	KAFIN	288.00	2K22	KLYSTRONEE	53.00
1220-A6	5100-5900 Mc	80	KASIX	327.00	6115	KLYSTRONEF	92.00
1220-A7	5925-6450 Mc	100	KASET	303.00	QK404	KLYSTROGEE	68.00
1220-A8	6200-7425 Mc	90	KALOC	303.00	5976	KLYSTROJAY	68.00
1220-A	KLYSTRON POWER SUPPLY						
	Without Tube		KANOT	235.00			
1201-B	Unit Power Supply		ASSET	85.00			
480-P4U3	Relay-Rack Adaptor Panel (Holds both oscillator and power supply)		UNIPANCART	12.00			

All klystron tubes except the 6043 are designed for relatively infrequent tuning. The oscillator will also operate with the TYPE 2K25 (8550-9660 Mc) and TYPE 2K26 (6250-7060 Mc) Klystrons,

PATENT NOTICE. See Note 4, page viii.



# PULSE AND NOISE GENERATORS



## PULSE AND TIME-DELAY GENERATORS

The rapid expansion of the electronics industry in the past fifteen years has been due as much to the rise of new fields as to the expansion of the older field of communications. Radar, long-distance navigation systems, electronic computation, and television are new areas in which high-speed switching and time measurements are fundamental tools. Starting with the development of the TYPE 869-A Pulse Generator for the Radiation Laboratory at the Massachusetts Institute of Technology in 1942, the General Radio Company has been continuously engaged in development work on pulse systems to provide science and industry with the best in equipment for the production of pulse waveforms for general laboratory applications.

Several quantities are important to the prospective purchaser of a pulse generator. The particular application will, of course, dictate which ones are of paramount importance:

- (1) The rise and decay times of the pulse.
- (2) The range of time duration of the pulse.
- (3) The range of pulse repetition rates.
- (4) The peak pulse power.
- (5) The output impedance of the generator.
- (6) The maximum possible duty ratio (pulse duration divided by pulse repetition period.)
- (7) Stability and accuracy of these quantities.

In an ideal pulse generator, the pulse would rise and fall instantaneously, and the duration could range from zero to infinity in time. There should, of course, be no limit on repetition frequency, and thus an ideal duty-ratio figure would be unity.

Practical pulse generators must necessarily fall short of these ideal criteria. The rise and decay times are generally limited by the bandwidth of the switch, mechanical or electronic, producing the pulse, and by the output coupling system connecting it to the load. Maximum repetition frequency is limited by the recovery transients of the pulse timing circuits and/or the maximum permissible duty ratio. The available pulse power is, in general, limited only by economic considerations of power supply and the output tubes, which must handle the average pulse power.

Under these constraints then, it is hardly surprising that no one pulse generator can adequately fill all possible applications.

### Unit Pulser

The TYPE 1217-A Unit Pulser, with a large adjustment range of repetition frequency and pulse duration and a self-contained oscillator, is an economical pulse source for low-power applications and for systems of up to 5-Mc bandwidth. It is excellent for such diverse applications as amplifier square-wave testing, studies of the transient response of networks, and as a pulse-frequency source for the driving of high-power pulse sources.

### Pulse Amplifier

The TYPE 1219-A Pulse Amplifier can be driven by any convenient source of pulses to produce an output pulse of current ranging up to 0.6 ampere. It provides

adequate energy to drive pulsed oscillators and will develop up to 30 volts in a 50-ohm load. Maximum duty ratio is 50%, which makes the unit useful for the production of high-energy square waves. Rise and decay times as short as 0.03 microsecond can be produced. Brief triggers at a low impedance can be produced for testing the performance and resolution of trigger circuits and delay lines in the megacycle range.

### Pulse, Sweep, Time-Delay Generator

The TYPE 1391-B Pulse, Sweep, and Time-Delay Generator is our most versatile pulse instrument. The rise and decay times for the push-pull output are both .015 microsecond, and the pulse duration ranges from .025 microsecond to 1.1 seconds. There are duty-ratio restrictions even though pulse current of .15 ampere is available to the load. Switched internal loads of 50 to 600 ohms are available.

An internal, wide-range, precision time-delay generator of high resolution and stability produces a delayed trigger pulse ranging from 1 microsecond to 1.1 seconds; coincidence circuitry is included for easy recalibration and complex synchronization. A wide variety of switching and external connection possibilities make this generator applicable to almost any conceivable laboratory application where pulses and time delays are desired.

### Time-Delay Generator

The TYPE 1392-A Time-Delay Generator extends the wide range delay concept first introduced in the 1391-A. It comprises a 1- $\mu$ sec to 1 sec delay circuit of high accuracy and stability, a 0-1- $\mu$ sec variable delay line, and a second six-decade circuit producing delays from 0.5  $\mu$ sec to 0.5 sec. These three units can be switched to perform many functions such as:

- (1) Production of precise delays (0-1  $\mu$ sec) with .004- $\mu$ sec resolution and .010- $\mu$ sec absolute accuracy.
- (2) Double delay generator with the two 6-decade delay circuits either in series or in parallel.
- (3) An extremely versatile gating and time selection coincidence system in which the 0.5- $\mu$ sec to 5-sec circuit is used as a gate whose initiation time is controlled by the 0-1 sec delay circuit.

In addition to 0.1- $\mu$ sec, 20-volt, synchronizing pulses for all circuits, the delay intervals are marked by gate waveforms.

## RANDOM-NOISE GENERATOR

The use of "white" noise as a tool in the measurement and test of electronic systems is another important modern development. The concept of wide-band testing, as contrasted to point-by-point measurements, saves valuable engineering time and often leads to more significant results. A new and increasingly important use of random noise is in the testing of structures, particularly missiles and rockets, both by high-level acoustic noise and by random vibration.

The TYPE 1390-B Random-Noise Generator, described on page 123, is a well-designed source for these tests at frequencies between 20 cps and 5 Mc.





### TYPE 1217-A UNIT PULSER

**USES:** The Unit Pulser is a compact, versatile and inexpensive source of pulse waveforms for the laboratory. The pulser is useful in transient studies on passive networks, square-wave testing of amplifier systems, and as a source of pulse-modulation voltage for rf signal generators and oscillators.

An internal oscillator makes the unit independent of external synchronizing signals for most applications. The Unit Pulser can also be used as a simple time-delay generator over its range of available pulse durations. One pulser may be used to delay the trigger pulse for a second unit.

**DESCRIPTION:** Four basic circuits (a blocking oscillator, a monostable multivibrator, a limiter, and a cathode-follower, phase-splitter output stage) are employed in the Unit Pulser.

The blocking oscillator provides the internal repetition frequencies, and its voltage is used

to speed up the leading edge of the pulse. The multivibrator produces the adjustable-duration pulse. The limiter is used to remove imperfections in the pulse and to prevent amplitude variations with repetition rate and duration. The cathode-follower phase-splitter output system provides either positive or negative output pulses.

#### FEATURES:

- Wide range of pulse durations and repetition rates.
- Fast rise time — .05  $\mu\text{sec}$ .
- Repetition rate can be set by external source, if desired.
- Pulse duration settings stable and accurate.
- Internal time delay of  $1/10 \mu\text{sec}$  permits leading edge of pulse to be visible on oscilloscope.

Block diagram of the Type 1217-A Unit Pulser showing the functional arrangement of internal circuits and connections to external equipment.

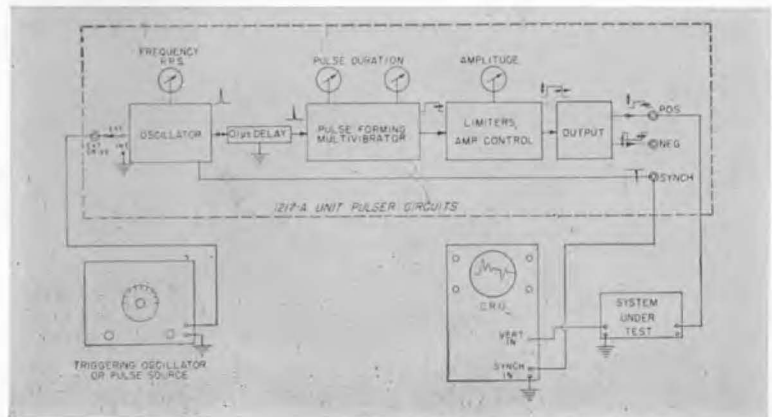

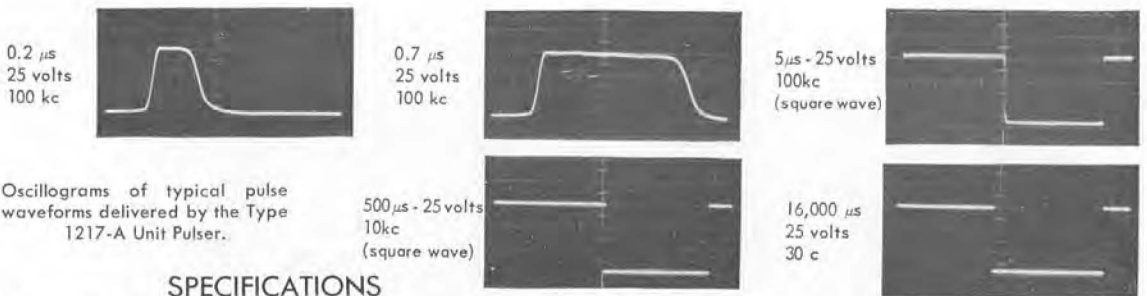

Oscillograms of typical pulse waveforms delivered by the Type 1217-A Unit Pulser.

### SPECIFICATIONS

#### Pulse Repetition Rates

**Internal:** 30 cps, 60 cps, both synchronized to power line (25 and 50 cps for TYPE 1217-AS1); 100 cps to 100 kc in 1, 2, 5 steps,  $\pm 15\%$  or 20 cps, whichever is greater.

**External:** 15 cps to 100 kc, positive, continuous.

**Pulse Duration:** Continuous coverage in four ranges 0.2 to 60,000  $\mu\text{sec}$ . Accuracy  $\pm 15\%$  or 0.2  $\mu\text{sec}$ , whichever is greater.

**Pulse Shape:** Rise time 50 nsec, decay time 150 nsec, with output terminals shunted by 15 pf and 1 M $\Omega$ . Overshoot may be set to be less than 5% of one-half the maximum amplitude; top of pulse is flat to within 5% of maximum amplitude.

**Minimum External Drive Voltage:** For continuous locking: 26 volts or less, rms, from 15 cps to 85 kc; 40 volts, up to 100 kc. A 10-volt pulse will lock continuously from 0 to 25 kc. TYPE 1210-C Unit R-C Oscillator is recommended as a driving source.

**Output Impedance:** 200 ohms for positive pulses, 1500 ohms for negative pulses.

**Open-Circuit Output Voltages:** 20 volts for pulses of either polarity; negative pulse of 50 volts when positive output terminal is grounded.

**Stability:** No time jitter is visible where a full period is displayed on an oscilloscope.

**Tube Complement:** 6AK5, 6AN5, 6AL5, 6485 and two 12AT7.

**Accessories Supplied:** 10:1 200-ohm attenuator.

**Power Input:** 300 volts, dc, 55 ma; 6.3 volts, ac, 60 cps, 2 amp. TYPE 1203-B Unit Power Supply is recommended. AC filament supply is necessary to synchronize the 30- and 60-cps pulse repetition frequencies. The pulser can be used on other supply frequencies up to 400 cps, but the 30- and 60-prf positions will not be synchronous. A 50-cps model, TYPE 1217-AS1, is listed below.

**Dimensions:** Width 15, height 5 $\frac{3}{4}$ , depth 6 $\frac{1}{4}$  inches (380 by 145 by 160 mm) over-all, including power supply, as shown above.

**Net Weight:** 5 $\frac{1}{4}$  pounds (2.4 kg), for generator only.

TYPE		CODE WORD	PRICE
1217-A	Unit Pulser.....	AMASS	\$250.00
1203-B	Unit Power Supply.....	ALIVE	50.00
1217-AS1	Unit Pulser (50 cps).....	AMASSPASHA	265.00
480-P4U3	Relay-Rack Adaptor Panel (7 in. high).....	UNIPANCART	12.00

## TYPE 1391-B PULSE, SWEEP, AND TIME-DELAY GENERATOR

**USES:** The TYPE 1391-B Pulse, Sweep, and Time-Delay Generator is an unusually versatile instrument which produces:

(1) Push-pull pulses of durations from 25 nanoseconds to 1.1 seconds at repetition rates to 250 kc;

System block diagram showing major circuit groups and their interconnections.

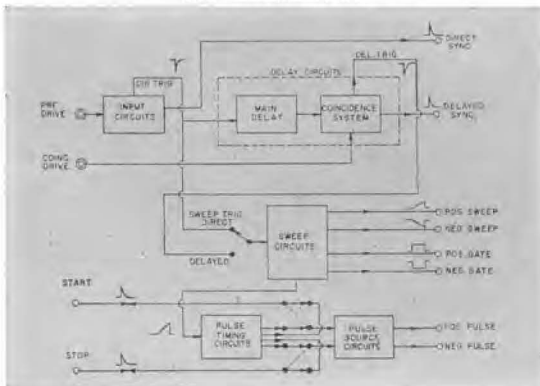

(2) Linear sweep voltages of durations from 3  $\mu\text{sec}$  to 0.12 sec;

(3) Time delays from 1  $\mu\text{sec}$  to 1.1 sec;

(4) Direct and delayed trigger pulses which can be used externally, or to delay the sweep and main pulse relative to the input signal.

The output pulse transition times (15 nanoseconds) are compatible with most modern oscilloscopes. The internal sweep makes it possible to display the pulse on its controlling sweep.

This generator has many applications in measurements and testing of equipment for echo-ranging, navigation, television, computing, telemetering, and research.

**DESCRIPTION:** The system block diagram and the accompanying time diagram outline the operation of the generator.

*Input Circuits*, when driven from an external signal of any wave shape, produce the direct





synchronizing pulse, which occurs at either a positive or negative zero crossing, as determined by a switch setting. This signal is available at panel terminals:

The *Delay Circuits* produce a delayed synchronizing signal, which can be used to start the pulse generating circuits.

The *Coincidence Circuit* produces, optionally, multiple delayed trigger and synchronizing pulses from signals introduced at the coincidence drive terminals.

The *Sweep Circuits*, started by either direct or delayed trigger, produce

- (1) a positive and a negative linearly-rising voltage, adjustable in time, and
- (2) positive and negative gate signals of the same duration as the sweep.

The *Pulse Timing Circuits* start and stop the output pulse. They operate from internal signals, external pulses, or a combination of the two, to produce multiple pulses.

The *Pulse Source Circuits* then produce

push-pull output pulses of adjustable amplitude and output impedance.

Terminals are provided to facilitate any desired interconnection of these outputs.

#### FEATURES:

- Complete versatility in one convenient package.
- Controls are logically arranged and easy to operate.
- Fast rise time.
- Wide ranges of pulse duration and delay.
- Low jitter — high accuracy.
- Pulse-forming and delay circuits stable against hum and line transients.
- No duty-ratio restrictions.
- Variable output impedance — 50 to 600 ohms.
- Coincidence circuitry makes possible multiple pulsing and time selection, as well as generation of low-jitter delays and output pulses.
- Pulse, sweep, and gate output, both positive and negative.

#### SPECIFICATIONS

**Input Synchronizing Signal:** May be any waveform; typical minimum amplitudes are 0.1 volt, rms, sine wave; 0.3 volt, peak-to-peak, square wave; 1 volt, peak-to-peak, positive or negative pulse.

**Direct Synchronizing Pulse:** Available at panel terminals; positive 75 volts up to 300 kc prf, 60 volts at 500 kc, 1  $\mu$ sec half-amplitude duration, 600 ohms.

#### TIME-DELAY CIRCUIT

**Range:** 1.0  $\mu$ sec to 1.1 sec in six ranges.

**Delay Dial Resolution:** 1 part in 8800.

**Accuracy:** Absolute,  $\pm 2\%$  of full scale, or  $\pm 3\%$  of scale reading  $+ .05 \mu$ sec, whichever is larger; incremental delay,  $\pm (1\% + .05 \mu$ sec).

**Maximum PRF:** 400 kc.

**Duty Ratio Effects:** Less than 2% error in delay for duty ratios up to 60%, at the low end, and up to 90% at the high end of each range.

**Delayed Synchronizing Pulse:** Positive, 60 v, 1.0- $\mu$ sec half-amplitude duration, 600-ohm cathode-follower output.



# GENERATORS

## PULSE



Stability:	LOW END OF DIAL	HIGH END OF DIAL
Time Jitter	1:10,000	1:50,000
10% Line Change	2:1000	2:10,000
Sudden 10% Line Transient	3:1000	3:10,000

### COINCIDENCE CIRCUITS

**Gate Duration:** 3 to 1000  $\mu$ sec.

**Gate Accuracy:**  $\pm 15\%$  or  $\pm 1 \mu$ sec, whichever is larger.

Coincidence driving circuit accepts either positive or negative input pulses. Source impedance should be low, have rise time less than 0.2  $\mu$ sec. Amplitudes between 5 and 20 volts for negative pulses and between 10 and 100 volts for positive pulses are acceptable.

### SWEEP CIRCUIT

**Sweep Duration:** 3, 6, 12  $\mu$ sec with 5-decade multiplier.

**Sweep Linearity:** Determined by the accuracy of pulse timing. On longer ranges, where time-delay effects are absent, the linearity is better than 1%.

**Sweep Amplitude:** Push-pull, each phase, 135 volts, nominal.

**Cathode-Follower Output:** 1- $\mu$ f blocking capacitors.

**Sweep Gate Amplitude:** Push-pull, each phase 40 volts nominal.

Positive sweep gate is cathode-follower output circuit with a 1- $\mu$ f coupling capacitor. Negative gate is amplifier output with 1- $\mu$ f blocking capacitor.

**Duty Ratio and Repetition Rate Effects:** Maximum repetition rate, 3- $\mu$ sec sweep, 250 kc.

### RANGE Maximum Frequency for 5% Error in Sweep Slope

Sweep Time	3 $\mu$ sec	6 $\mu$ sec	12 $\mu$ sec
$\times 1$	150 kc	100 kc	60 kc
$\times 10$	16 kc	12 kc	7 kc
$\times 10^2$	1.6 kc	1.2 kc	700 cps
$\times 10^3$	160 cps	120 cps	70 cps
$\times 10^4$	16 cps	12 cps	7 cps

### Pulse Generating Circuit

**Pulse Duration:** (Timed by sweep) .025 to 2.5, .05 to 5.0, and .05 to 10.0  $\mu$ sec between half-amplitude points, with decade multipliers to a maximum of 100,000  $\mu$ sec. Pulse can be extended to 1.1 seconds if timed by delay circuit.

**Pulse Duration Accuracy:** After sweep calibration,  $\pm 1\%$  of dial reading or  $\pm .02 \mu$ sec, whichever is larger.

**Pulse Rise Time:** Where the load  $R_L C_S$  is negligible with

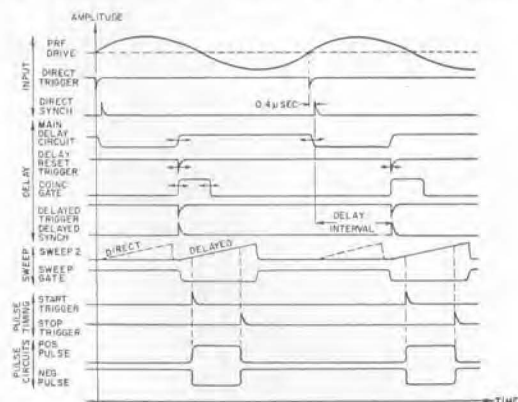

Timing diagram for the complete system.



View of generator and power supply.

respect to  $15 \times 10^{-9}$  sec, the rise time will be faster than 15 nsec. Higher load impedance or higher shunt  $C_S$  will result in increased rise time.

Typical rise times (in nanoseconds) are as follows:

LOAD IMPEDANCE	POSITIVE PULSE		NEGATIVE PULSE		
	RISE	DECAY	RISE	DECAY	
50 $\Omega$ terminated	15	12	13	15	overshoots approx 3%
600 $\Omega$ with 8-pf oscilloscope probe	40	40	38	38	

**Pulse Shape:** Overshoot is less than 3% of pulse amplitude when the generator is correctly terminated. Pulse ramp-off does not exist.

**Pulse Duty Ratio:** Unity duty ratio is possible.

**Output Impedance:** 50, 72, 94, 150, 600 ohms, all  $\pm 10\%$ .

**Output Pulse Amplitude:** 150-ma current source; voltage from each phase of push-pull channel, 0.15  $Z_0 \pm 20\%$ .

Typical nominal amplitudes, 50 ohms, 7.5 v; 72 ohms, 10 v; 94 ohms, 14 v; 150 ohms, 22 v; 600 ohms, 90 v.

**DC Component Insertion:** Terminals provided. DC can be moved  $\pm 25$  volts for all output impedances except 600 ohms.

**Accessories Supplied:** Interconnecting cables, TYPE CAP-22 Power Cord, 2 TYPE 874-C58 Cable Connectors, spare fuses.

**Other Accessories Available:** TYPE 1219-A Unit Pulse Amplifier for higher power output.

**Accessories Required:** Trigger source; practically any laboratory oscillator is adequate; the TYPE 1210-C Unit R-C Oscillator is recommended.

### Tube Complement: Generator:

1 - 5963	4 - 6AV5GA	1 - 6AW8
1 - 6BQ7A	2 - 12BH7	2 - 12BY7
3 - 6U8	5 - 5965	Power Supply
8 - 6485/6AH6WA	2 - 5687	1 - 0C3
3 - 6AN5	1 - 0A2	1 - 6AK5
6 - 12AX7	2 - 6550	1 - 6AS7

**Power Supply Input:** 105 to 125 (or 210 to 250) volts, 50 to 60 cps, 385 watts. Three-wire power cord.

**Dimensions:** Generator, width 19, height 14, depth 12  $\frac{1}{2}$  inches (485 by 355 by 320 mm) over-all. Power Supply, width 19, height 8  $\frac{3}{4}$ , depth 12  $\frac{1}{2}$  inches (485 by 225 by 320 mm) over-all.

**Net Weight:** Generator, 30 pounds (14 kg); power supply, 62 pounds (28.5 kg).

TYPE		CODE WORD	PRICE
1391-BM	Cabinet Model (incl Power Supply) . . . . .	EDIFY	\$2025.00
1391-BR	Relay-Rack Model (incl Power Supply) . . . . .	EBONY	2025.00







### TYPE 1219-A UNIT PULSE AMPLIFIER

**USES:** Used with any pulse source, this amplifier produces pulses with many different characteristics of duration, duty ratio, and impedance level at higher power levels. The combination of Unit Pulser and Unit Pulse Amplifier constitutes a high power output pulse generator of very moderate cost and small size. The Pulse Amplifier is equally useful with the TYPE 1391-B Pulse, Sweep, and Time-Delay Generator.

**DESCRIPTION:** The Pulse Amplifier (which is not a conventional linear device) reproduces the prf and width of an input triggering pulse, but the amplitude, and to some degree the rise time, of the output pulse are determined by the amplifier circuits. It may be driven by either positive or negative input pulses, to produce output pulses of either polarity.



#### FEATURES:

- High output current — up to 620 ma.
- Fast rise and decay times — 20 to 50 nsec.
- No prf limit.
- Low overshoot.

#### SPECIFICATIONS

**Input Pulse:** Minimum necessary amplitude ranges from 50 volts for a negative pulse to 2.5 volts for a positive pulse from the TYPE 1217-A Unit Pulser. For most conditions, 20 to 30 volts is adequate.

**Input Impedance:** Positive drive, approximately 50 kilohms shunted by 30 pf. Negative drive, impedance is nonlinear, 1 kilohm for low driving-pulse amplitude (<2 volts approx), about 33 kilohms for higher amplitudes.

**Output Pulse:** The open-circuit output pulse voltage is between 10 and 250 volts and is the product of the impedance and available current listed below.

(1) Impedance:

- a. Positive pulse: 50, 75, 100, 150 ohms, all  $\pm 10\%$ .
- b. Negative pulse: 50, 75, 100, 150, 200, 250, 300 ohms, all  $\pm 10\%$ ; 570 ohms  $\pm 20\%$ , designed to permit maximum output voltage.

(2) Output Current: Depends upon the position of the duty-ratio selector switch and upon the duty ratio.

DUTY RATIO	OUTPUT CURRENT (ma)			
	POSITIVE PULSE		NEGATIVE PULSE	
	DR Sw 0.2	DR Sw 0.5	DR Sw 0.2	DR Sw 0.5
0.05	620 $\pm 10\%$	350 $\pm 15\%$	575 $\pm 10\%$	330 $\pm 15\%$
0.1	580 $\pm 10\%$	325 $\pm 15\%$	550 $\pm 10\%$	300 $\pm 15\%$
0.2	560 $\pm 10\%$	300 $\pm 15\%$	475 $\pm 10\%$	275 $\pm 15\%$
0.5	—	250 $\pm 15\%$	—	225 $\pm 15\%$

(3) Transition Times: These depend upon the transition times, magnitude, and polarity of the input pulse, as well as on the settings of the output impedance, polarity, and duty-ratio switches. Under optimum conditions, i.e., with an infinitely fast driving pulse, the output rise time for current will range from 20 to 50 nanoseconds. With either slower driving pulses or higher output impedance, the transition times decrease. Typically,

when the driving source is the TYPE 1217-A Unit Pulser, the output transition times are about 0.1  $\mu\text{sec}$ .

(4) Maximum Pulse Duration: The maximum duration of the pulse depends only on the tolerable ramp-off during the "on" period. If 10% is chosen, then the maximum "on" period for positive pulses is 10 msec and for negative pulses 4 msec; with the TYPE 1217-A, the maximum for negative pulses is 1 msec, for positive pulses, 10 msec.

(5) Pulse Shape: Overshoot less than 5% of amplitude on any output switch position.

(6) Noise: Hum on the output pulse less than 1% of pulse amplitude.

(7) Maximum Duration: Determined to some extent by the input pulse voltage, and tolerable droop.

Input	MAXIMUM DURATION TO 10% DROOP	
	Positive Output	Negative Output
Negative 30 v	2000 $\mu\text{sec}$	4000 $\mu\text{sec}$
Negative 55 v	10,000	4000
Positive 10 v	10,000	6000

The droop is approximately linear, hence the maximum durations for 5% droop are  $\frac{1}{2}$  the above figures.

**Tube Complement:** One 6J6, one 12AU7, two 5763.

**Power Input:** 105-125 volts, 50-60 cps. Input power is 75 watts, full load, 115-volt line. Three-wire captive power cord. Operation on supply frequencies up to 400 cps is possible, with reductions in pulse output current up to 10%.

**Accessories Supplied:** One TYPE 874-C58 Cable Connector; spare fuses.

**Dimensions:** Width 9  $\frac{1}{2}$ , height 5  $\frac{3}{4}$ , depth 6  $\frac{1}{4}$  inches (240 by 145 by 160 mm), over-all.

**Net Weight:** 8  $\frac{1}{2}$  pounds (3.9 kg).

TYPE	CODE WORD	PRICE
1219-A	ACRID	\$210.00
480-P4U2	UNIPANBOLT	11.00
	Unit Pulse Amplifier.....	
	Relay-Rack Adaptor Panel (7 inches high).....	





### TYPE 1392-A TIME-DELAY GENERATOR

**USES:** This instrument generates wide ranges of precise time intervals, which can be combined in several ways to produce analog timing signals for the measurement, test, and calibration of electronic equipment and systems.

In communications, its two delayed outputs (which can be independent) are advantageous in the testing of time-sharing systems, such as telemetry and pulse communication equipment.

In radio ranging and navigation, its high accuracy and extended ranges make it useful for tests and range calibration on radar, sonar, and loran.

In the design and test of computing systems the ability to set short time delays, the brief (0.1  $\mu$ sec) synchronizing pulses, and high repetition rates for short delays make it particularly useful.

For geophysical and physiological research the long delays make it a very desirable instrument. It can be used for the measurement of short time intervals and other quantities that can be translated into time variables.

In conjunction with a crystal-controlled time-mark generator, it is possible to establish delays with crystal-controlled precision in any time or time-equivalent unit.

**DESCRIPTION:** An external periodic signal voltage of almost any wave-shape will set the prf. A direct synchronizing pulse of 0.1- $\mu$ sec duration is generated at this frequency and becomes the time reference for the instrument. Two delay circuits provide delays relative to

this reference sync pulse of from 0 to 1.1 seconds and from 0.5  $\mu$ sec to 0.5 second, respectively. Each delay circuit generates a brief (0.1  $\mu$ sec) synchronizing pulse at a time determined by its control settings. Delay No. 1 is always initiated by the direct synchronizing pulse. Delay No. 2 can be initiated by either the direct synchronizing pulse or the Delay No. 1 synchronizing pulse. Thus, the two delays can be operated in series, (adding in delay times) or in parallel, producing two independent delays.

Delay No. 1 uses a passive variable delay line with a precisely-calibrated dial to produce a delay variable from 0 to 1  $\mu$ sec in 10- $\mu$ sec divisions. This delay line serves either as a first (0.1  $\mu$ sec) range for Delay No. 1 or as a vernier on the 1- $\mu$ sec to 1.1-sec electronically produced delay. Other features of Delay No. 1, in addition to its range, are: high accuracy, resolution, and linearity; and stability against noise, aging, and power-line effects.

Delay No. 2, in addition to its use as an independent delay circuit, provides the feature of time selection. When used to operate the built-in coincidence circuitry, pulses from a timing comb coherent with the prf drive can be selected to provide precise delays independent of internal error or drift within the TYPE 1392-A. The 0.5- $\mu$ sec minimum delay of Delay No. 2 permits the selection of a single 1- $\mu$ sec pulse from a 1-Mc train so that 1- $\mu$ sec steps of delay are provided. In addition, the coincidence feature provides for the production of bursts of pulses,



### FEATURES:

- Wide range.
- Can be driven up to 300 kc.
- Passive electronic vernier with 4- $\mu$ sec resolution.

- Stable delays of high accuracy and resolution.
- Linear scales at all delays.
- Coincidence circuitry for calibrations and time selection.
- Two delay outputs.

Over-all timing diagram with DELAY No. 2 in "AFTER DELAY NO. 1 SYNC" connection. The Coincidence Gate (not shown) is identical with that for the Type 1391-B, page 116.

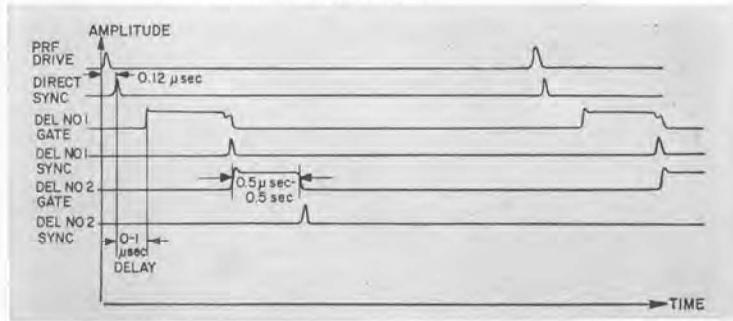

### SPECIFICATIONS

#### INPUT SYSTEM

##### Voltage:

- Sine wave, 0.1 volt, rms.
- Square wave, 0.3 volt, peak to peak.
- Pulse (negative or positive), 1 volt peak ac or dc, input trigger threshold control provided.

##### Frequency: Dc to over 300 kc.

##### Time Delay (input to direct sync): 0.12 $\pm$ 0.02 $\mu$ sec.

##### Direct Sync Pulse:

- Amplitude, 15 volts or more, positive or negative.
- Duration, 0.13  $\pm$  0.02  $\mu$ sec.
- Impedance, 93 ohms or less.

#### DELAY NO. 1

##### Delay Range: 0-1.1 sec in seven ranges.

**Accuracy:** 1  $\mu$ sec-1.1 sec range,  $\pm$ 1% of dial reading; 0-1  $\mu$ sec range,  $\pm$ 0.1  $\mu$ sec.

**Stability:** Jitter, 1:30,000 at worst.  
Drift, 1:10,000 with 20% line variation.

**Resolution:** 0-1  $\mu$ sec, .004  $\mu$ sec.  
1  $\mu$ sec-1 sec, 1:8800.

**Duty Ratio Effects:** Less than dial accuracy to 60%; 5% at duty ratio of 80%.

#### DELAY NO. 1 SYNC

**Duration:** 0.1  $\pm$  0.02  $\mu$ sec.

**Amplitude:** 25 volts or more positive or negative.

**Impedance:** 93 ohms, output impedance.

**Max PRF:** 0-1  $\mu$ sec range, 300 kc;  
1  $\mu$ sec-1.1 sec range, 250 kc (at 1  $\mu$ sec).

#### DELAY NO. 2, OR COINCIDENCE CIRCUIT

**Range:** 0.5  $\mu$ sec-0.5 sec (six decade ranges).

**Accuracy:**  $\pm$ 3% of dial reading.

**Stability:** Jitter, 1:20,000.  
Line Drift, 1:5000 for 20% line change.

**Resolution:** 1:2000.

#### DELAY NO. 2 SYNC

**Duration:** 0.13  $\mu$ sec  $\pm$  0.02  $\mu$ sec.

**Amplitude:** 20 volts or more, positive or negative.

**Impedance:** 93 ohms.

**Duty Ratio Effects:** Full scale, less than dial accuracy at 60% duty ratio; bottom of scale, less than dial accuracy at 20% duty ratio. Max prf 300 kc.

#### Coincidence:

Input, positive or negative pulse, 5 volts or over.

Input frequency, 1 cps to 1.7 Mc (for single pulse selection).

Input pulse rise time, 0.1  $\mu$ sec or less at 5 v.

**Power Supply:** 105 to 125 (or 210 to 250) volts, 50-60 cps, 180 watts at 115 volts.

**Tube Complement:** Six 5965, three 6350, two each 6U8, 6AU6, 12AT7, 5751, 6AV5-GA, one each 6BQ7-A, 6AU8-A, 12AX7, 6485, 6AN8, 5651.

**Accessories Supplied:** TYPE CAP-22 Power Cord; spare fuses; test lead; four TYPE 874-C58 Cable Connectors.

**Dimensions:** Width 19, height 8 $\frac{3}{4}$ , depth 14 $\frac{1}{2}$  inches (485 by 225 by 370 mm) over-all. Depth behind panel, 13 inches (330 mm).

**Net Weight:** 35 lb (16 kg).

TYPE		CODE WORD	PRICE
1392-AM	Time-Delay Generator (Bench Model).....	ENTRY	\$1095.00
1392-AR	Time-Delay Generator (Relay-Rack Model)....	EXTOL	1095.00

PATENT NOTICE. See Notes 8 and 20, page viii.

For pulse generation, see TYPE 1391-B Pulse, Sweep, and Time-Delay Generator, page 116.





## DELAY LINE

### TYPE 314-S86 VARIABLE DELAY LINE

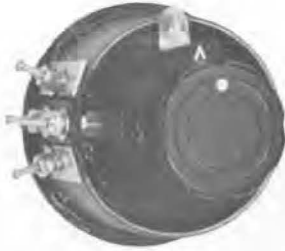

**USES:** This variable delay line finds general application as a wide-band phase-shifting device, particularly when it is desired to delay a wide-band signal without introducing phase distortion. Thus, it is used as a component in pulse and in video-frequency systems such as computers, radar and beacon systems, and television circuits.

**DESCRIPTION:** In this delay line, good transient response is obtained by a skewed-turn

method of delay equalization\*, in which the plane of each turn of the winding is at an acute angle to the axis of the coil. By careful control of the manufacturing process, the "baseline ripple," caused by variation in characteristic impedance along the line, has been reduced to 5% or less of the signal amplitude. End reflections have been minimized by the use of tapered capacitance elements at the ends of the winding. Materials are chosen for reliable operation under wide variations of temperature and humidity.

**FEATURES:**

- Delay is constant with frequency over a wide range.
- No ringing or overshoot.
- Characteristic impedance is uniform along the line.

\* For complete description, see F. D. Lewis and R. M. Frazier, "A New and Better Variable Delay Line." *General Radio Experimenter*, 31, 7, October, 1936.

### SPECIFICATIONS

- Delay Range:** 0 to 0.5  $\mu$ sec.
- Characteristic Impedance:** 200 ohms  $\pm 15\%$  at frequencies up to 4.5 Mc.
- DC Resistance:** Not over 20 ohms.
- Delay vs. Frequency (with respect to delay at 1 Mc):**  $\pm 1\%$  at 10 Mc;  $\pm 2\%$  at 15 Mc;  $\pm 4\%$  at 20 Mc measured at maximum delay. See accompanying plot.
- Amplitude Response vs. Frequency:** Loss, 9% (0.8 db) at

dc; 30% (3 db) at 6 Mc; 60% (8 db) at 10 Mc; 90% (20 db) at 25 Mc at maximum delay. See also accompanying plot.

**Pulse and Step Response:** See accompanying oscillograms.  
**Dimensions:** Diameter, 3 $\frac{3}{8}$  inches (81 mm); depth behind panel, 1 $\frac{1}{2}$  inches (38 mm); shaft diameter,  $\frac{3}{8}$  inch (10 mm); knob is furnished.  
**Net Weight:** 6 ounces (0.2 kg).

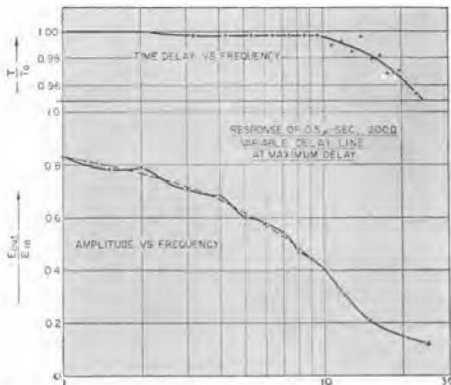

Time delay and amplitude versus frequency with resistive termination as measured at full delay on 0.5- $\mu$ sec, 200-ohm variable delay line with skewed winding.

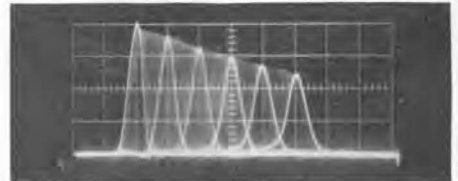

Oscillogram showing pulse shape and amplitude as delay setting is varied. Tektronix 541 Oscilloscope, 53K/54K Pre-Amplifiers; sweep, 0.1  $\mu$ sec/cm.

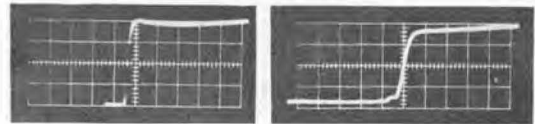

Step response of 0.5- $\mu$ sec, 200-ohm variable delay line with skewed winding; (left) step input, (right) step output at 0.5- $\mu$ sec delay. Scope photos taken on Tektronix 541, 0.1- $\mu$ sec/cm sweep.

TYPE	CODE WORD	PRICE
314-S86 Variable Delay Line	DELAY	\$60.00

PATENT NOTICE. See Note 20, page viii.

The Type 301-S104 Delay Line, having a total delay adjustable from zero to 25 nanoseconds, with a rise time of approximately 2.4 nanoseconds, is now available. Further information available on request.



### TYPE 1390-B RANDOM-NOISE GENERATOR

**USES:** This instrument generates wide-band noise of uniform spectrum level, particularly useful for noise and vibration testing in electrical and mechanical systems. Some of its many uses are:

*as a broad-band signal source for*

- frequency-response measurements.
- When the TYPE 1390-B Generator is used for frequency-response measurements, the TYPE 1554-A Sound and Vibration Analyzer provides a narrow-band detector. Its one-third-octave band permits measurement even at very low frequencies. With the TYPE 1521-A Graphic Level Recorder, continuous records of level vs. frequency can be plotted from the output of the analyzer.
- intermodulation and cross-talk tests.
- simulator of telephone-line noise.
- measurements on servo amplifiers.
- noise interference tests on radar.
- determining meter response characteristics.
- setting transmission levels in communication circuits.

*in acoustic measurements, to provide a signal for*

- reverberation testing.

lyzer can also be used with this generator to produce one-third-octave bands of noise which are useful in acoustic measurements, especially reverberation testing.

- sound attenuation of ducts, walls, panels, or floors.
- acoustic properties of materials.
- room acoustic measurements.
- demonstrating noise properties in a classroom or laboratory.

*with a suitable power amplifier to drive a loud-speaker to produce high-level acoustic noise for*

- fatigue testing of structures or components.
- and to drive a vibration shaker for*
- structural tests of components or assemblies.

**DESCRIPTION:** A gas-discharge tube with a transverse magnetic field applied is used as a noise source in this instrument. The noise output of the tube is amplified in a two-stage amplifier. Between the two stages, the noise spectrum is shaped with low-pass filters to provide ranges to 20 kc, to 500 kc, and to 5 Mc.

The output system consists of a continuous attenuator control followed by a 4-step attenuator of 20 db per step. Metered levels from

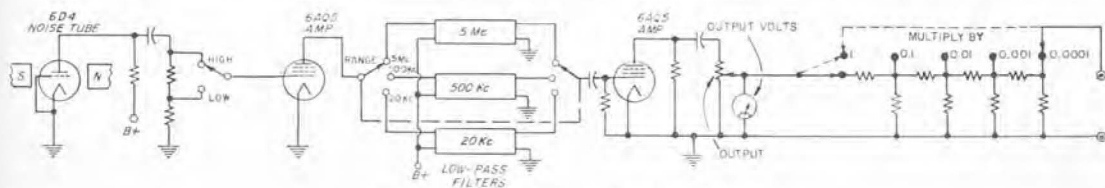

Elementary schematic of the generator.



Extendible legs permit a tilted position (left); panel extensions (right) adapt the instrument for relay-rack mounting.

over 3 volts to below 30 microvolts are conveniently obtained. When the attenuator is used, the output impedance remains essentially constant as the level is varied by the continuous-output control.

The instrument cabinet may be used for either bench or relay-rack mounting and has the added feature of extendible front legs to permit the instrument to be used in a tilted position for easier meter reading.

### FEATURES:

- Wide frequency range, 5 cps to 5 Mc.
- Uniform spectrum level over audio range.
- Output variable from 30  $\mu$ volts to 3 volts.
- Thermal relay for warm-up time delay.
- Low hum level by use of dc on heaters.
- Low external noise field.
- Regulated heater for gas tube, to stabilize output.
- Built-in precision attenuator.

### SPECIFICATIONS

**Frequency Range:** 5 cps to 5 Mc.

**Output Voltage:** Max open-circuit output is at least 3 volts for 20-ke range, 2 volts for 500-ke range, and 1 volt for 5-Mc range.

**Output Impedance:** Source impedance for max output is approx 900 ohms. Output is taken from a 2500-ohm potentiometer. Source impedance for attenuated output is 200 ohms. One output terminal is grounded.

**Typical Spectrum Level (with one volt rms output):** 20-ke band: 5 mv for 1-cps band. 500-ke band: 1.2 mv for 1-cps band. 5-Mc band: 0.6 mv for 1-cps band.

**Spectrum Level Uniformity:** 20-ke range, within  $\pm 1$  db from 20 cps to 20 kc; 500-ke range, within  $\pm 3$  db from 20 cps to 500 kc; 5-Mc range, within about  $\pm 8$  db from 500 kc to 5 Mc. Noise energy is also present beyond these limits. The level is down 3 db at 5 cps. See plot.

**Waveform:** Noise source is a gas tube that has good normal or Gaussian distribution of amplitudes for narrow ranges of the frequency spectrum. Over wide ranges the distribution is less symmetrical because of dissymmetry introduced by the gas tube. Appreciable clipping occurs on the 500-ke and 5-Mc ranges.

**Voltmeter:** Rectifier-type averaging meter measures output. It is calibrated to read rms value of noise.

**Attenuator:** Multiplying factors of 1.0, 0.1, .01, .001, and .0001. Accurate to  $\pm 3\%$  to 100 ke, within  $\pm 10\%$  to 5 Mc.

**Tube Complement:** Two 6AQ5; one each, 6D4, 3-4, 115NO30T thermal relay.

**Power Input:** 105 to 125 (or 210 to 250) volts, 50 to 60 cps. Power input is approximately 50 watts. Three-wire power cord. This generator will also operate satisfactorily on line frequencies up to 400 cps.

**Accessories Supplied:** Power cord, spare fuses.

**Mounting:** Metal cabinet; aluminum panel, finished in gray crackle. Panel extensions are available for relay-rack use.

**Dimensions:** Width 12 $\frac{3}{4}$ , height 7 $\frac{1}{2}$ , depth 9 $\frac{3}{4}$  inches (325 by 190 by 250 mm) over-all. Panel height for relay-rack mounting is 7 inches (178 mm).

**Weight:** 12 pounds (5.5 kg).

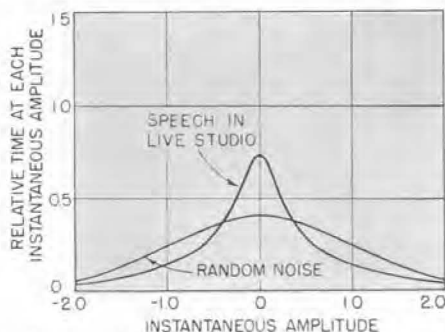

Typical amplitude distribution curves showing similarity between speech and random noise.

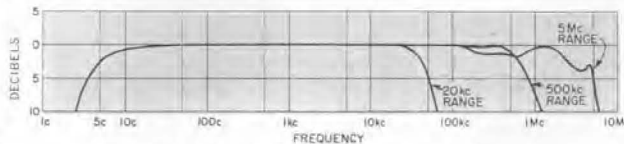

Typical spectrum level characteristics.

TYPE		CODE WORD	PRICE
1390-B	Random Noise Generator.....	BUGLE	\$295.00
480-P412	Panel Extensions (pair).....	EXPANELLAP	7.00 Pair

For a more complete description, ask for Reprint No. E-110.

# METERS



The meters described in this section include a vacuum-tube voltmeter, oxide-rectifier meters for measurement of input voltage and output power, a megohmmeter, an electrometer to measure millivolts, microamperes and megamegohms, and a modulation monitor. All of these represent pioneer work of the General Radio Company.

## ▶ VOLTMETERS

The first instrument combining a diode peak rectifier with a degeneratively stabilized dc amplifier to indicate the rectified voltage was introduced in 1937. Advantages of this arrangement are wide frequency range, high inherent stability, a convenient circuit for obtaining a multirange meter, and a calibration substantially independent of tube characteristics. Voltmeters of this type are now used in every conceivable type of application. This circuit is the basis of the highly accurate *Type 1800-B Vacuum-Tube Voltmeter*, which covers frequencies from 10 cycles per second to 600 megacycles per second, a span of  $6 \times 10^7$ . For higher frequencies, a coaxial, rectifier-type instrument is available, the *TYPE 874-VR, -VI* (page 50). Very low voltages (down to  $0.5 \mu\text{v}$ ) at audio frequencies can be measured by comparison with the *Type 546-C Microvolter*.

In the General Radio Standardizing Laboratory, each voltmeter is calibrated by means of a highly precise potentiometer against a certified standard cell. Precise ac calibration voltages are obtained by comparison with the dc standard cell. Meters are individually aged and are checked for accuracy and drift over a sufficiently long period of time to assure that they will remain well within specified accuracy.

## ▶ MEGOHMMETER

The first megohmmeter was introduced in 1936 and applied the degenerative vacuum-tube dc voltmeter to the conventional ohmmeter circuit. The degenerative circuit not only gives stability and linearity, but per-

mits a large voltage swing to take place at the input of the tube and greatly increases the effective input resistance. The *Type 1862-B Megohmmeter*, using this circuit, measures insulation resistance with test potentials of either 500 volts or 50 volts applied to the sample.

## ▶ POWER METERS

General Radio Company also pioneered in the application of oxide-rectifier meters. The first constant-resistance output-power meter of this kind was introduced in 1929 and was followed by the *Type 583-A Output-Power Meter* which combines the oxide-rectifier meter with a resistive load and a tapped transformer, providing a sensitive audio-frequency power meter for load resistances varying over a range of 8000 to 1.

A larger model, the *Type 783-A Output-Power Meter*, measures power up to 100 watts.

## ▶ ELECTROMETER

The *Type 1230-A D-C Amplifier and Electrometer* is basically a millivoltmeter with an extremely high input resistance. It can also be used conveniently for the measurement of very low currents ( $5 \times 10^{-15}$  ampere), high resistances ( $5 \times 10^{11}$  ohms) and as a dc amplifier for very low voltages. A recorder can be operated from the output.

## ▶ MODULATION METER

The *Type 1931-B Amplitude-Modulation Monitor* measures percentage modulation for broadcast and other radio-telephone transmitters. The modulated output signal is rectified to produce an ac voltage proportional to the instantaneous value of the carrier envelope and a dc voltage proportional to the average carrier amplitude. The ratio of these voltages is continuously indicated by a voltmeter calibrated in modulation percentage. A flashing lamp indicates modulation peaks in excess of any pre-set level.

TYPE	NAME	QUANTITY MEASURED	RANGE	NOMINAL ACCURACY	POWER SUPPLY	SEE PAGE
546-C	Microvolter	Voltage	0.5 $\mu\text{v}$ to 1 v	$\pm 3\%$	Audio Oscillator	131
583-A	Output-Power Meter	Power Impedance	0.1 mw to 5 w 2.5 to 20,000 $\Omega$	$\pm 0.5$ db $\pm 7\%$	None	134
783-A	Output-Power Meter	Power Impedance	0.2 mw to 100 w 2.5 to 20,000 $\Omega$	$\pm 0.25$ db $\pm 2\%$	None	134
1230-A	Electrometer	Voltage Current Resistance	0.5 mv to 10 v $5 \times 10^{-16}$ to $10^{-8}$ a $3 \times 10^5$ to $5 \times 10^{14}$ $\Omega$	2% to 4% 3% to 10% 3% to 8%	Ac Line	128
1800-B	Vacuum-Tube Voltmeter	Voltage, Ac or Dc	0.1 to 150 v*	$\pm 2\%$	Ac Line	126
1862-B	Megohmmeter	Resistance	0.5 to 2,000,000 M $\Omega$	$\pm 3\%$	Ac Line	130
1931-B	Amplitude-Modulation Monitor	Modulation Percentage	0 to 100%	$\pm 2\%$ to $\pm 4\%$	Ac Line	132

\* Multipliers are available to extend range to 1500 volts.

**TYPE 736-A WAVE ANALYZER** for amplitude and frequency measurements of complex electrical signals is listed on page 225.

**TYPE 1932-A DISTORTION AND NOISE METER** (page 227) measures distortion, noise, and hum level in audio systems.





## TYPE 1800-B VACUUM-TUBE VOLTMETER



The General Radio TYPE 1800-B Vacuum-Tube Voltmeter has gained widespread acceptance as an accurate and stable meter for use over a wide frequency range.

It combines the accuracy of a laboratory instrument with the necessary durability for everyday laboratory and production-line use. It measures alternating voltage at frequencies up to several hundred megacycles, as well as dc voltages of either polarity.

Competent circuit design, the best available components, and a mechanical design that emphasizes convenience in use combine to produce the features listed at right.

**DESCRIPTION:** The high-frequency probe contains an acorn-type diode rectifier connected by very short leads to the small, button-type input capacitor mounted on a low-loss insulating disk. Except for the small area of this in-

sulation at the front, the probe is completely shielded. Various fittings and terminations can be attached to the metal probe cap. The cable, which also supplies heater power to the diode in the probe, carries the rectified voltage to a dc amplifier and indicating meter in the cabinet.

The dc amplifier uses a balanced twin triode in a highly degenerative circuit. The rectified alternating voltage is applied directly to the control grid of one triode, and a diode, which balances the effect of the initial-velocity current in the rectifying diode, is connected to the control grid of the second triode. The indicating meter is connected in series with precision range-changing resistors between the cathodes of the amplifying twin triodes.

**FEATURES:**

- High accuracy,  $\pm 2\%$ .
- Wide frequency range; full range is covered *without disassembly of probe* and without addition of external capacitor.
- Probe is shielded against strong rf fields.
- Probe cap can be bolted to ground plane to eliminate high-frequency errors resulting from inductance in ground connection.
- Coaxial fitting and 50-ohm coaxial resistor are supplied for use on probe.
- Calibration is stable and is substantially independent of tube characteristics.
- Regulated power supply eliminates fluctuation in meter indication and zero setting over wide range of line voltages.
- High input impedance.
- Illuminated mirror-type scale.
- Polarity switch for dc measurements.
- Wire-wound resistors are used in all positions that influence calibration stability.
- Only three controls to handle all functions.
- Dc open-grid provision.
- Both sides of the input can be above dc ground.

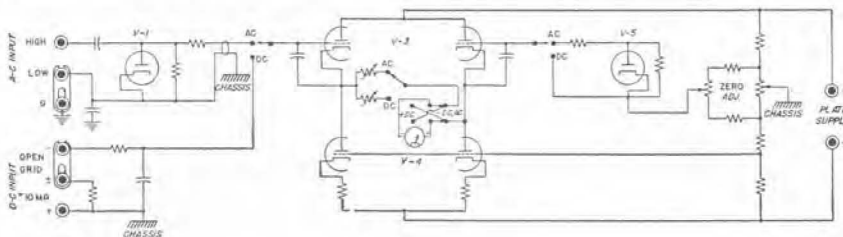

Elementary schematic diagram for the Type 1800-B Vacuum-Tube Voltmeter.





### SPECIFICATIONS

**Voltage Range:** 0.1 to 150 volts ac, in six ranges (0.5, 1.5, 5, 15, 50, and 150 volts, full scale); .01 to 150 volts dc, in six ranges (0.5, 1.5, 5, 15, 50, and 150 volts, full scale).

**Accuracy:** Dc,  $\pm 2\%$  of full scale; ac,  $\pm 2\%$  of full scale for sinusoidal voltages, subject to frequency correction (see curve). The total warm-up decrease in sensitivity is about 1% of the indicated value on the 1.5-volt range and 3 to 4% of the indicated value on the 0.5-volt range. About one-half of this drift occurs in the first hour. The calibration is set to be correct after complete warm-up.

**Waveform Error:** On the higher ac voltage ranges, the instrument operates as a peak voltmeter, calibrated to read rms values of a sine wave, or 0.707 of the peak value of a complex wave. On distorted waveforms the percentage deviation of the reading from the rms value may be as large as the percentage of harmonics present. On the lowest range the instrument approaches rms operation.

**Frequency Error:** At high frequencies, resonance in the input circuit and transit-time effects in the diode rectifier introduce errors in the meter reading. The resonance effect causes the meter to read high and is independent of the applied voltage. The transit-time error is a function of the applied voltage and causes the meter to read low. The accompanying curves show the frequency range for 1-db resultant error. The resonant frequency with cap on but plug removed is about 1050 Mc. Correction curves are supplied.

At the indicated frequency of 15 cps, the meter indication begins to fluctuate as it tends to follow the voltage change within each cycle.

**Input Impedance:** See plot; the equivalent parallel capacitance at radio frequencies is 3.1 pf with the probe cap

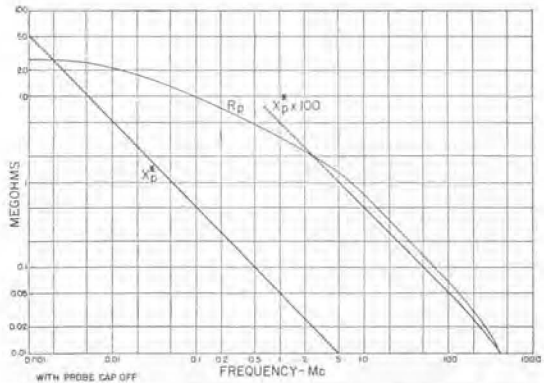

Plot of components of input impedance as a function of frequency.

and plug removed. The probe cap and plug add approximately 1.2 pf.

On the dc ranges two values of input resistance are provided, 10 megohms and open grid.

**Power Supply:** 105 to 125 (or 210 to 250) volts ac, 50 to 60 cps. The instrument incorporates a voltage regulator to compensate for supply variations over this voltage range. The power input is less than 25 watts.

Instrument will operate satisfactorily on power-supply frequencies up to 400 cps.

**Tube Complement:**

- |              |             |         |
|--------------|-------------|---------|
| 2 — 9005     | 1 — 6SL7-GT | 1 — 3-4 |
| 1 — 6SU7-GTY | 1 — 6AT6    | 2 — 991 |
| 1 — 6C4      | 1 — 6X5-GT  |         |

**Accessories Supplied:** TYPE CAP-22 Power Cord, spare fuses, TYPE 274 and TYPE 874 terminations, and 50-ohm coaxial terminating resistor for probe.

**Mounting:** Crackle finish aluminum panel mounted in a shielded hardwood cabinet. The cable and probe are stored in the cabinet.

**Dimensions:** Width 7 $\frac{3}{8}$ , height 11 $\frac{1}{4}$ , depth 7 $\frac{1}{2}$  inches (185 by 285 by 190 mm), over-all.

**Net Weight:** 13 $\frac{3}{4}$  pounds (6.5 kg).

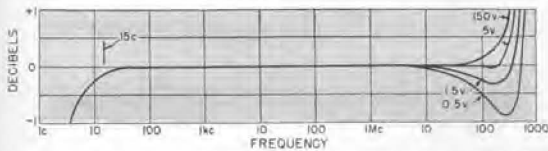

Frequency characteristics — data taken with complete probe, cap on, but banana plug removed.

TYPE		CODE WORD	PRICE
1800-B	Vacuum-Tube Voltmeter	DUCAT	\$490.00



#### TYPE 1800-P2 HIGH-FREQUENCY MULTIPLIER

For AC Use Above 100 kc

**Multiplication Ratio:** 10:1  $\pm 5\%$ ; can be adjusted to  $\pm 1\%$  on voltmeter.

**Input Impedance:** Resistance 100 times that of voltmeter; capacitance, 2 pf with probe cap off, 1.5 pf with cap on.

**Dimensions:** Diameter 1 $\frac{3}{8}$ , length added to end of probe 2 inches (42 by 51 mm).

**Net Weight:** 4 ounces (115 g).



#### TYPE 1800-P3 LOW-FREQUENCY MULTIPLIER

For DC and AC Use up to 100 kc

**Multiplication Ratio:** Dc, 10:1  $\pm 1.5\%$ ; ac, 10:1  $\pm 5\%$ ; can be adjusted to match voltmeters at any frequency or for less than 3% error, 20 cps to 20 kc, less than 5% up to 100 kc.

**Input Impedance:** 10 megohms shunted by 10 pf.

**Dimensions:** Width 5, height 2, depth 2 inches (130 by 51 by 51 mm).

**Net Weight:** 8 ounces (230 g).

TYPE		CODE WORD	PRICE
1800-P2	Multiplier	ABODE	\$29.00
1800-P3	Multiplier	ABHOR	\$40.00



## TYPE 1230-A D-C AMPLIFIER AND ELECTROMETER

### FOR VOLTAGE, CURRENT, AND RESISTANCE MEASUREMENTS



**USES:** The D-C Amplifier and Electrometer is basically a millivoltmeter with extremely high input resistance. It measures:

- Voltage — 0.5 millivolt to 10 volts.
- Current —  $5 \times 10^{-16}$  to  $10^{-3}$  amperes.
- Resistance —  $3 \times 10^5$  to  $5 \times 10^{14}$  ohms.

These quantities are indicated on a panel meter, and output is available to operate recorders and other equipment.

Because of its high sensitivity and excellent stability, this instrument has a wide range of applications in science, engineering, and industry. Typical examples include the measurement of:

- Ionization currents, photo currents, grid currents in electron tubes, and time-current curves of capacitors during charge and discharge.
- Piezoelectric potentials, bioelectric potentials, contact potentials, electrostatic field potentials, and pH indications.
- Back resistance of silicon-junction diodes, interconductor resistance of cables, insulation resistance of electrical equipment, and voltage coefficient of resistance.

It amplifies weak dc and low-frequency voltages to operate recorders and other equipment.

**DESCRIPTION AND FEATURES:** The *circuit* is a three-stage direct-coupled amplifier that acts as a highly degenerated cathode follower and has high over-all transconductance. Excellent linearity is obtained even on the lowest scales.

➤ *Voltage* is measured directly; *current* is measured in terms of the voltage drop across a standard resistor, through which the current flows; and *resistance* in terms of a standard voltage source connected in series with the standard and unknown resistors.

➤ To achieve *maximum stability*, power-supply voltages are stabilized; components are carefully chosen and well aged; chassis and sub-assemblies are shock mounted.

➤ *High input resistance*, even under conditions of high humidity, is achieved by use of an electrometer tube and by enclosure of the input grid lead in silicone-treated glass. Input resistance selector has switch contacts that are mounted on individual teflon bushings set in a metal base that connects to a guard point.

➤ *Input stage is completely shielded*, and the coaxial input terminal permits this shielding to be extended to the unit under test. A fully shielded chamber, the TYPE 1230-P1 Component Shield, is available as an accessory, within which components to be measured can be quickly and easily connected.

➤ *Guard terminals are provided*. The low input terminal can be grounded or not, as desired.

➤ The output meter has two voltage scales and two resistance per decade.

➤ Terminals are provided for connecting an external meter or recorder. The Esterline-Angus (or equivalent) 5-ma Graphic Recorder is recommended and the TYPE 1230-AE D-C Amplifier and Electrometer can be supplied in an Esterline-Angus case to match the recorder. More sensitive recorders such as the TYPE 1521-A Graphic Level Recorder can be shunted for 5-ma operation.

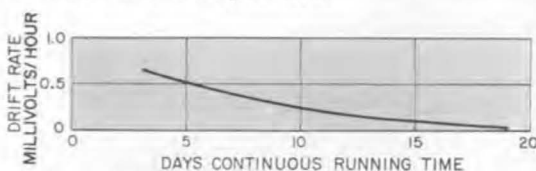

Typical drift after tubes are changed.



# METERS

## ELECTROMETER



Type 1230-P1 Component Shield (with shield cover removed) plugged into the input terminal at the rear of the electrometer.



Type 1230-AE D-C Amplifier and Electrometer with a recorder.

### SPECIFICATIONS

#### Ranges of Measurement

**Voltage:**  $\pm 30$ , 100, and 300 millivolts,  $\pm 1$ , 3, and 10 volts dc, full scale.

**Current:**  $\pm 1$  milliamperes ( $10^{-3}$  amp) dc, full scale, to  $\pm 300$  millimicroamperes ( $3 \times 10^{-13}$  amp) full scale.

**Resistance:** Direct-reading from 300 kilohms to 10 megamegohms ( $10^{13}$  ohms) full scale ( $5 \times 10^{11}$  ohms at smallest meter division). There are 16 ranges, two per decade. Voltage across the unknown resistance is 9.1 volts.

#### Accuracy

**Voltage:**  $\pm 2\%$  of full scale on the five highest ranges,  $\pm 4\%$  of full scale on the 30-mv range.

**Current:**  $\pm 3\%$  of full scale from  $10^{-3}$  to  $10^{-9}$  amp,  $\pm 10\%$  of full scale from  $3 \times 10^{-10}$  to  $3 \times 10^{-13}$  amp.

**Resistance:**  $\pm 3\%$  from  $3 \times 10^8$  to  $10^{10}$  ohms at full scale (low-resistance end),  $\pm 8\%$  from  $3 \times 10^{10}$  to  $10^{13}$  ohms.

**Frequency Characteristic:** With a 1500-ohm load at the OUTPUT terminals, the frequency characteristic is flat within 5% from zero to 10, 30, 100, 300, 1000 and 3000 cps at the 30-, 100-, 300-millivolt, 1-, 3-, and 10-volt ranges, respectively.

**External DC Supply:** By the use of batteries, or other suitable external supply, the resistance range can be extended, the voltage across the unknown can be increased, and the voltage coefficient of resistors can be measured.

With a 300-volt battery, the highest resistance range is  $10^{13}$  ohms full scale ( $6 \times 10^{10}$  ohms at the smallest meter division). The full battery voltage appears across the unknown resistance. The maximum permissible voltage is 600 volts if the external supply is grounded; somewhat greater if ungrounded.

**Resistance Standards:**  $10^1$ ,  $10^2$ ,  $10^3$ ,  $10^4$ ,  $10^5$ ,  $10^6$ ,  $10^7$ , and  $10^{11}$  ohms. The switch also includes "zero" and "infinity" positions. The  $10^1$ - and  $10^2$ -ohm resistors are wire wound and are accurate to  $\pm 0.25\%$ . The  $10^3$ -,  $10^4$ -, and  $10^5$ -ohm resistors are of deposited-carbon construction and are accurate to  $\pm 1\%$ . The  $10^6$ -,  $10^{10}$  and  $10^{11}$  resistors are carbon, have been treated to prevent adverse humidity effects, and are accurate to  $\pm 5\%$ . A switch position permits quick checking of the higher-

resistance standards in terms of the wire-wound units.  
**Input Resistance:** The input resistance is determined by the setting of the resistance standards switch. In the infinity position, it is approximately  $10^{11}$  ohms.

**Drift:** Less than 2 mv per hour after one-hour warmup.  
**Output:** Voltage, current and resistance are indicated on a panel meter. Terminals are available for connecting a recorder (such as the Esterline-Angus 5-ma or 1-ma graphic recorder). The recorder can have a resistance of up to 1500 ohms.

**Input Capacitance:** Less than 35 pf.

#### Amplifier Characteristics

**Maximum Transconductance:** 167 mmhos (for 30 mv input, the output current is 5 ma.)

**Output Load:** Maximum allowable recorder resistance is 1500 ohms.

**Terminals:** The input is connected through a TYPE 874 coaxial terminal assembly at the rear of the instrument. In addition, there are three "low" terminals to provide versatility in guard and ground connections, as required, for example, in three-terminal network measurements.  
**Input Switch:** A panel switch permits disconnection of the unknown without transient electrical disturbances in either the unknown or the measuring circuit.

**Input Insulation:** Entirely teflon or silicone-treated glass.  
**Humidity, Line-Voltage Effects:** Negligible.

**Tube Complement:** One 5886 electrometer, one CK6418, one 6AN5, one 6AL5, one 6E27, and three 0B2.

**Accessories Supplied:** One TYPE 874-411 Adaptor, one TYPE 1230-P1-300 Panel Adaptor Assembly, two TYPE 274-MB Plugs, one TYPE 274-SB Plug, spare fuses and TYPE CAP-22 Three-Wire Power Cord.

**Other Accessories Available:** TYPE 1230-P1 Component Shield, TYPE 1521-A Graphic Level Recorder.

**Power Supply:** 105 to 125 (or 210 to 250) volts, 50 to 60 cps. Power input is approximately 45 watts at 115 volts. Instrument will operate satisfactorily on power-supply frequencies up to 400 cps.

**Mounting:** Aluminum panels and cabinet.

**Dimensions:** Width  $7\frac{5}{8}$ , height  $13\frac{1}{4}$ , depth 9 inches (195 by 340 by 230 mm), over-all.

**Net Weight:**  $15\frac{1}{4}$  pounds (7 kg).

For a more complete description of this instrument refer to the *General Radio Experimenter*, Volume 30, No. 10, March, 1956.

TYPE		CODE WORD	PRICE
1230-A	D-C Amplifier and Electrometer.....	MASON	\$440.00
1230-AE	D-C Amplifier and Electrometer in Esterline-Angus Case.....	MISTY	520.00
1230-P1	Component Shield.....	MANOR	40.00

PATENT NOTICE. See Notes 4 and 15, page viii.





### TYPE 1862-B MEGOHMMETER



**USES:** Rugged, versatile, and safe, this megohmmeter rapidly measures wide ranges of resistance at either of two test voltages. The 50-volt level is useful in resistance measurements on printed circuits, transistor circuit components, and miniaturized circuit compo-

nents. The 500-volt level is a standard value in the measurement of the insulation resistance of rotating machinery, transformers, cables, capacitors, appliances, and other electrical equipment.

Stabilized power supply and time constant permit rapid and accurate measurement of the leakage resistance of capacitors.

Guard and ground terminals permit measurement of the grounded and ungrounded sections of three-terminal resistors.

**DESCRIPTION:** The megohmmeter consists of a stabilized power supply, a complement of resistance standards, and an indicating meter. The indicator is a balanced, dc, vacuum-tube voltmeter that has two volts full-scale sensitivity and a very high input resistance.

**FEATURES:**

- Direct-reading and simple to operate.
- Test voltages of 50 and 500 permit approximate measurement of voltage coefficient.
- Voltage can be removed from unknown terminals by setting switch to CHECK or DISCHARGE positions, thus permitting connections to be made without danger of shock.
- Guard and ground terminals provided.

**SPECIFICATIONS**

**Range:** 0.5 to 2,000,000 megohms at 500 volts and to 200,000 megohms at 50 volts. There are six decade steps selected by a multiplier switch.

**Scale:** Each resistance scale up to 500,000 megohms utilizes 90% of the meter scale. Center-scale values are 1, 10, 100, 1000, 10,000 and 100,000 megohms for 500-v operation.

**Accuracy:** From  $\pm 3\%$  at the low-resistance end of each decade, to  $\pm 12\%$  (accuracy to which the scale can be read) at the high-resistance end up to 50,000 megohms. There can be an additional  $\pm 2\%$  error at the top decade. For 50-volt operation, there is an additional  $\pm 2\%$  error on all but the 0.5-to-5-megohms decade where the additional error can be  $\pm 5\%$ .

**Voltage On Unknown:** 50 or 500 volts, as selected by switch on front panel. Indicator lamp is lighted when 500 volts are applied. At resistance values below 0.5 megohm, the applied voltage drops to limit the current to safe values. Voltage across unknown is 500 volts within  $\pm 10$  volts, or it is 50 volts within  $\pm 4$  volts. This voltage source is stabilized for operation from 105-125 volt lines (or 210-250 volt lines).

**Terminals:** Unknown, ground and guard terminals. At two positions of a panel switch, all voltage is removed from all terminals to permit connection of the unknown in safety. In one of the positions, the UNKNOWN terminals are shunted to discharge the capacitive component of the unknown. All but the ground terminals are insulated.

**Calibration:** Switch position is provided for standardizing the calibration at 500 volts.

**Tube Complement:** One each, 12AU7, 0A2, 6X4, 2X2-A, 6AB4, 6AU6, 5651.

**Power Supply:** 105 to 125 (or 210 to 250) volts, 40 to 60 cps, 25 watts. Instrument will operate satisfactorily on power-supply frequencies up to 400 cps.

**Accessories Supplied:** Spare fuses, two color-coded test leads.

**Mounting:** Crackle-finished aluminum panel and cabinet with carrying handle and phenolic protective sides.

**Dimensions:** Width  $9\frac{1}{8}$ , height  $10\frac{1}{8}$ , depth  $11\frac{3}{4}$  inches (235 by 260 by 300 mm), over-all.

**Net Weight:**  $15\frac{1}{2}$  pounds (7.5 kg).

TYPE		CODE WORD	PRICE
1862-B	Megohmmeter.....	JUROR	\$255.00

**MEGOHM BRIDGE:** The TYPE 544-B Megohm Bridge, a bridge for resistance measurements in the megohm range, is described on page 8.

**ELECTROMETER:** The TYPE 1230-A D-C Amplifier and Electrometer, described on page 128, measures resistances as high as  $5 \times 10^{14}$  ohms as well as very low voltages and currents.





## TYPE 546-C AUDIO-FREQUENCY MICROVOLTER

**USES:** The TYPE 546-C Audio-Frequency Microvolter used in conjunction with an oscillator is a useful source of small, known audio-frequency voltages. For response measurements of amplifiers, transformers, and other audio equipment such a source of known input voltage is extremely valuable. The microvolter can also be used to measure small voltages by substitution methods.

**DESCRIPTION:** This instrument consists, essentially, of a constant-impedance attenuator and a voltmeter by means of which the input to the attenuator is standardized. A switch controls the output voltage in decade steps, while an individually calibrated dial provides continuous control over each decade.

**FEATURES:**

➤ An excellent frequency characteristic, extending from very low frequencies up to 100,000 cps.

➤ Excellent accuracy is obtainable for absolute voltage levels as well as for voltage ratios in gain or loss measurements.  
➤ Both decibel and voltage scales are provided.



### SPECIFICATIONS

**Output Voltage Range:** From 0.5 microvolt to 1.0 volt open circuit, when the input voltage is set to the standardized reference value (2.2 volts).

**Accuracy:** For open-circuit output voltages the calibration is accurate within  $\pm(3\% + 0.5 \text{ microvolt})$  for output settings above 1 microvolt and for all frequencies between 20 and 20,000 cps. For higher frequencies up to 100 kc the calibration is accurate within  $\pm 5\%$  for output settings above 100 microvolts. These specifications apply only where waveform and temperature errors are negligible (see below).

In calculating ratios of output voltages at a given frequency, the accuracy of any given reading is within  $\pm(2\% + 0.5 \text{ microvolt})$ , at frequencies up to 100,000 cps. At frequencies above 20 kc this accuracy applies only at levels above 100 microvolts.

The microvolter can be used on dc with an external dc meter. Internal meter can be calibrated for dc.

**Output Impedance:** The output impedance is approximately 600 ohms, constant with setting within  $\pm 5\%$ . No correction of the output voltage is necessary for load impedances of the order of 100,000 ohms and greater.

**Input Impedance:** Approximately 600 ohms, substan-

tially independent of output setting on all but the highest multiplier position.

**Waveform Error:** The accuracy of the microvolter as a calibrated attenuator or voltage divider is independent of waveform. The absolute accuracy of the output voltage calibration depends on the characteristics of the input copper-oxide rectifier voltmeter, which has a small waveform error that depends in turn on both the phase and the magnitude of harmonics present in the input. This error in the voltmeter can, in general, be neglected when the microvolter is used with ordinary laboratory oscillators. The rectifier-type voltmeter itself introduces some distortion unless the source impedance is very low. With a 600-ohm source the distortion introduced is about 0.2%.

**Temperature Error:** The accuracy of the calibration is independent of temperature when the microvolter is used as an attenuator or voltage divider. The absolute accuracy is affected slightly by temperature because of change in the voltmeter characteristics. The necessary correction for temperatures from 65 to 95 F is furnished with the instrument. The effects of humidity are negligible.

**Power Source:** The driving oscillator must be capable of furnishing about 2.2 volts across 600 ohms, or approximately 8 mv.

**Terminals:** Jack-top binding posts are mounted on standard 3/4-inch spacing.

**Mounting:** Aluminum panel and cabinet.

**Dimensions:** Width 10, height 7 1/8, depth 6 1/8 inches (255 by 185 by 160 mm), over-all.

**Net Weight:** 6 1/2 pounds (3 kg).

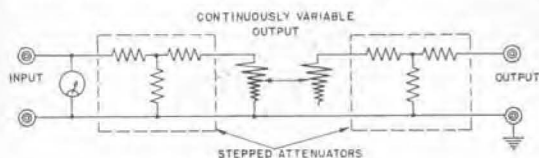

TYPE	CODE WORD	PRICE
546-C	CROWN	\$155.00
Audio-Frequency Microvolter*		

\* Reg. U. S. Pat. Off.





## TYPE 1931-B

# AMPLITUDE-MODULATION MONITOR

FCC APPROVAL NO. 3-107

**USES:** The Modulation Monitor is used in broadcasting and radio telephone stations to measure and to monitor the transmitter modulation, as well as for periodic measurements of transmitter frequency response and distortion (with the TYPE 1932-A Distortion and Noise Meter). Transmitter manufacturers find it useful in the production testing of transmitter performance.

The TYPE 1931-B Modulation Monitor performs the following specific functions:

1. Measurement of percentage of modulation on either positive or negative peaks.
2. Overmodulation indication.
3. Program-level monitoring.
4. Measurement of carrier shift when modulation is applied.
5. Measurement of the transmitter audio-frequency response.
6. Supplies a demodulated output for distortion measurements.
7. Supplies a 600-ohm output for audio monitoring.

**DESCRIPTION:** As shown in the elementary circuit schematic the essential elements of the monitor are a linear rectifier, a semi-peak volt-

meter to indicate continuously the percentage modulation, and a trigger circuit actuating an over-modulation alarm.

In addition, two auxiliary audio output circuits operating from a separate diode rectifier are provided. One of these, at 600 ohms, is intended for audible monitoring; the other, a high-impedance circuit, gives a faithful reproduction of the carrier envelope with less than 0.1% distortion, under most conditions, and can be used for distortion and noise-level measurements with the General Radio TYPE 1932-A Distortion and Noise Meter.

The TYPE 1931-B Modulation Monitor incorporates unusual mechanical design features. Chassis is designed for access from front of rack for service and tube replacement. Test jacks and signal flow lines marked on chassis facilitate maintenance operations.

### FEATURES:

- Accuracy and reliability.
- Speed and simplicity of operation.
- Low rf power required.
- Overmodulation indicator is not affected by small change in carrier level.
- Terminals are provided for remote meters.
- Advanced mechanical design — easy access.



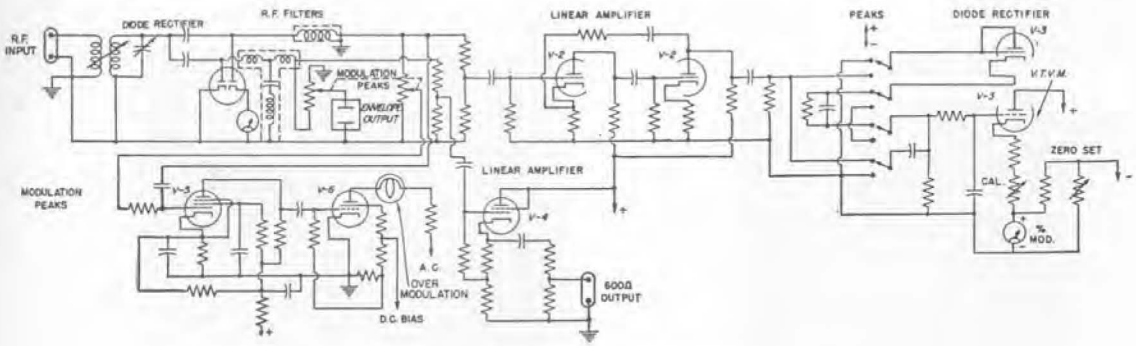

Elementary schematic diagram of the Type 1931-B Modulation Monitor.

## SPECIFICATIONS

**Range:** Modulation percentage, 0 to 110%, indicated by meter on positive peaks, 0 to 100% on negative peaks. The flashing lamp is adjustable to operate from 0 to 100% on negative peaks.

**Carrier-Frequency Range:** The monitor will operate at any carrier frequency from 0.5 to 60 megacycles. A single set of coils (either 0.5 to 8 megacycles or 3 to 60 megacycles) is supplied with each instrument, unless both sets are specifically ordered.

**Carrier-Frequency Input Impedance:** About 75 ohms in the broadcast band, increasing slightly at higher carrier frequencies and varying somewhat with input tuning.

**Accuracy:** The over-all accuracy of measurement at a modulating frequency of 400 cps is  $\pm 2\%$  of full scale at 0% and 100%, and  $\pm 4\%$  of full scale at any other modulation percentage.

**Detector Linearity:** The distortion in the diode detector is very low for frequencies up to 7500 cps. Above this frequency, a small amount of negative-peak clipping occurs, reaching 5% at the extreme high end of audio range at 15,000 cps and 100% modulation.

**RF Power:** In the broadcast range the maximum rf power requirement is about 0.5 watt.

**Warning Lamp Circuit:** The OVERMODULATION lamp will flash whenever the negative modulation peaks exceed the setting of the MODULATION PEAKS dial by 2% or more modulation, for audio frequencies between 30 and 7500 cps. For higher audio frequencies, the percentage overmodulation required to flash the lamp increases slightly.

The accuracy of the dial calibration is  $\pm 2\%$  of full scale.

**Meter Circuit:** The response of the PERCENTAGE MODULATION meter circuit is flat, within  $\pm 0.25$  db, between 50 and 15,000 cps, and within  $\pm 0.1$  db between 100 and 10,000 cps.

Either positive or negative modulation peaks may be read. Calibration in db below 100% modulation is provided.

The meter dynamic characteristic meets FCC specifications for modulation monitors.

**Audio Monitoring Output:** The audio output amplifier is flat, within  $\pm 1.0$  db, from 30 to 45,000 cps. The internal impedance is 600 ohms. Distortion is less than 0.2%. Open-circuit output voltage is about 300 millivolts.

**Fidelity-Measuring Output:** Flat within  $\pm 1.0$  db between 30-30,000 cps with TYPE 1932-A Distortion and Noise Meter connected. Distortion less than 0.1%, under most conditions.

Output level varies inversely with setting of MODULATION PEAKS dial, thus providing reasonably uniform input to distortion meter at all modulation levels. Average output level, approximately 1.5 volts, into 100k $\Omega$  load.

Residual noise and hum level will not exceed -80 db.

**Auxiliary Output:** A multipoint connector at the rear of the instrument provides a means of connecting:

1. A remote Percentage Modulation Meter (TYPE MEDS-14), which can be disconnected by a switch.
2. To a 600-ohm output for audio monitoring.
3. The TYPE 1932-A Distortion and Noise Meter.

**Tube Complement:** Two 6SN7-GT, two 6SJ7, one 6AL5, one 2050, two 0D3, one 6X5-GT.

**Power Supply:** 105 to 125 (or 210 to 250) volts, 50 to 60 cps. Power input is approximately 50 watts. Three-wire power cord.

**Accessories Supplied:** Multipoint connector, TYPE CAP-22 Power Cord, spare fuses, and one set of input tuning coils (specify frequency range desired).

**Mounting:** The instrument is relay-rack mounted.

**Panel Finishes:** Standard General Radio crackle. Certain other grays which can be processed in quantity can also be supplied.

**Dimensions:** Panel length 19 by height 8 $\frac{3}{4}$  inches (480 by 225 mm). Depth behind panel, 10 inches (255 mm).

**Net Weight:** 32 $\frac{3}{4}$  pounds (14.9 kg).

TYPE		CODE WORD	PRICE
1931-B	Modulation Monitor (.5 to 8 Mc) . . . . .	TARRY	\$650.00
1931-B	Modulation Monitor (3 to 60 Mc) . . . . .	TOPIC	650.00

For a complete description, see *General Radio Experimenter*, Vol 33, No 2, February 1959.



OUTPUT POWER METERS



**USES:** The output power meters indicate directly the audio-frequency power that a source delivers into any desired load. They are widely used to determine the output characteristics and internal impedance of lines, oscillators, amplifiers, transformers, transducers, and other networks. Two models are offered with maximum readings of 5 watts and 100 watts respectively.

**DESCRIPTION:** Functionally, the system is an adjustable load across which is connected a voltmeter reading directly in watts dissipated in the load. An auxiliary db scale is provided.

**FEATURES:**

- Direct-reading in power and impedance.
- Auxiliary decibel scale.
- Wide ranges.

SPECIFICATIONS

**TYPE 783-A**

**Power Range:** 0.2 milliwatt to 100 watts in five decade ranges. An auxiliary decibel scale with multiplier reads from -10 to +50 decibels above 1 milliwatt.

**Impedance Range:** 2.5 to 20,000 ohms. Forty discrete impedances, distributed approximately logarithmically.

**Impedance Accuracy:** Within  $\pm 2\%$  of the indicated value, except at the higher frequencies for high-impedance settings. At 15,000 cps the input impedance error is about 5% for impedances from 10,000 to 20,000 ohms.

**Power Accuracy:** The indicated power is accurate to  $\pm 0.25$  db at full-scale reading. At the lowest impedance multiplier setting (2.5 to 20 ohms) there may be an additional error of 0.2 db due to switch contact resistance when the highest power range is used.

The over-all frequency characteristic of the power indication is flat within  $\pm 0.5$  db from 20 cps to 10,000 cps; within  $\pm 0.75$  db to 15,000 cps.

**Waveform Error:** Calibrated in rms values for a sinusoidal applied voltage. When nonsinusoidal voltages are applied, the error will depend on the magnitude and phase of the harmonics present.

**Mounting:** The instrument is mounted on an aluminum panel in a hardwood cabinet.

**Dimensions:** Width 8, height 18, depth 7 inches (205 by 460 by 180 mm), over-all.

**Net Weight:** 17 pounds (7.8 kg).

**TYPE 583-A**

**Power Range:** 0.1 to 5000 milliwatts in four decade ranges. An auxiliary scale with multiplier reads from -10 to +37 decibels above 1 milliwatt.

**Impedance Range:** 2.5 to 20,000 ohms. Forty discrete impedances, distributed approximately logarithmically, are obtained.

**Accuracy:** The maximum error in full-scale power reading does not exceed 0.5 decibel between 150 and 2500 cps, nor does it exceed 1.5 decibels at 20 and 10,000 cps. The average error is 0.3 decibel at 30 and 5000 cps, and 0.6 decibel at 20 and 10,000 cps.

The maximum error in impedance does not exceed 7% between 150 and 3000 cps, nor does it exceed 50% at 20 and 10,000 cps. The average error is 8% at 30 and 5000 cps and 20% at 20 and 10,000 cps.

**Waveform Error:** Calibrated in rms values for a sinusoidal applied voltage. When nonsinusoidal voltages are applied, the error will depend on the magnitude and phase of the harmonics present.

**Mounting:** The instrument is mounted on an aluminum panel in a hardwood cabinet.

**Dimensions:** Width 10, height 7, depth 6 inches (255 by 180 by 155 mm), over-all.

**Net Weight:**  $8\frac{1}{4}$  pounds (3.8 kg).

TYPE		CODE WORD	PRICE
583-A	Output Power Meter	ABUSE	\$185.00
783-A	Output Power Meter	ABBEY	410.00





# POWER SUPPLIES



While most General Radio instruments have their own self-contained power supplies, some have been designed for use with separate power supplies for versatility and economy. These Unit Power Supplies are also useful for general laboratory purposes because they combine small physical size with high quality and high performance.

Most of the Unit Instruments use Unit Power Supplies. These instruments can all be operated from the general-purpose TYPE 1203-B Unit Power Supply. For critical applications, the TYPE 1201-B Unit Regulated Power Supply provides constant voltage, greatly reduced ripple, and higher current ratings.

The TYPE 1205-B Adjustable Regulated Power Supply is primarily a general-purpose instrument which provides a regulated output adjustable from 0 to 300 volts at a maximum current of 200 milliamperes.

Any of these Unit Power Supplies can be used with any Unit Instrument. Locking strips are provided with Unit Instruments in the rectangular type of cabinet to clamp the instrument solidly to the power supply.

Adaptor panels are available for relay-rack

mounting each of these power supplies alone or with another Unit Instrument:

TYPE 480-P4U1 Panels for TYPE 1201-B or TYPE 1203-B.

TYPE 480-P4U2 Panels for TYPE 1205-B.

TYPE 480-P4U3 Panels for TYPE 1201-B or TYPE 1203-B with any one of the TYPES 1206-B, 1210-C, 1212-A, 1213-D, 1217-A, or 1220-A.

TYPE 480-P5UC1 Panels for the TYPE 1201-B or TYPE 1203-B and TYPE 1211-B or TYPE 1215-B.

TYPE 480-P4UC1 Panels for TYPE 1201-B or TYPE 1203-B and TYPE 1208-B.

TYPE 480-P4UC2 Panels for TYPE 1201-B or TYPE 1203-B and TYPE 1209-B or 1209-BL.

The TYPE 1263-B Amplitude-Regulating Power Supply regulates the plate-supply voltage of the uhf and vhf Unit Oscillators to maintain a preset oscillator output voltage. This is particularly valuable when the oscillator is used for automatic display or for plotting of amplitude response data. Square-wave modulation at 1 kc is also provided by this power supply.

The TYPE 1264-A Modulating Power Supply produces 100% pulse and square-wave modulation of vhf and uhf oscillators. Although designed especially for the TYPE 1361-A UHF Oscillator, it can be used with most Unit Oscillators. This instrument can also be used as a source of regulated dc power, adjustable from 200 to 300 volts.

Two power supplies are available for the operation of battery-operated instruments from an ac line: The TYPE 1261-A Power Supply for the TYPE 1550-A Octave-Band Noise Analyzer, and the TYPE 1262-B Power Supply for the TYPE 1551-C Sound-Level Meter.



Unit Instruments plug directly into Unit Power Supplies with a multipoint connector.

TYPE	OPERATED FROM	OUTPUT	REMARKS	SEE PAGE
1203-B	115 v, 60 cps	6.3 v ac, 300 v dc.		137
1201-B	115 v, 60 cps	6.3 v ac, 300 v dc.	Regulated 300 v.	137
1205-B	115 v, 60 cps	6.3 v ac, 0 to 300 v dc, —150 v dc.	Regulated 0–300 v; —150 v.	136
1263-B	115 v, 60 cps	6 v dc, 0 to 300 v dc.	For amplitude control of Unit Oscillators.	138
1264-A	115 v, 50 to 1000 cps	6.3 v ac, 200 to 300 v, dc; 160 to 210 v, square waves.	For pulse and square-wave modulation of Unit Oscillators.	139
1261-A	115 v, 60 cps	1.5 or 3 v dc, 133 v dc, open circuit.	Replaces battery in Octave-Band Ana- lyzer.	137
1262-B	115 v, 60 cps	1.2 v dc, 75 v dc, open circuit.	Attaches to Sound-Level Meter.	137



## TYPE 1205-B ADJUSTABLE REGULATED POWER SUPPLY

### FEATURES:

- Adjustable output voltage from 0 to 300 volts dc.
- Excellent regulation down to zero output.
- Low hum level.
- Small size — over-all volume is less than  $\frac{1}{5}$  that of conventional supplies.
- High power output — 120 watts.

**DESCRIPTION:** The TYPE 1205-B Adjustable Regulated Power Supply combines the features of a series regulator and a controlled rectifier. The fast-acting series regulator provides a low output impedance over a wide bandwidth, while the high-efficiency controlled rectifier maintains constant voltage drop across the series regulator. Thus the series

regulator always operates at the optimum operating point, and the power dissipation is held to the same minimum value regardless of the output voltage setting or of line-voltage variations. Furthermore, the regulator performance is the same at any output voltage from 0 to 300 volts.

In addition to the 0-to-300-volt regulated dc output, the instrument provides a -150-volt regulated dc bias voltage and two unregulated ac outputs which can be connected in parallel for 6.3 volts at 10 amperes or in series for 12.6 volts at 5 amperes.

The output voltages are available at binding posts on the panel and at a multipoint connector in the side of the cabinet. Both the dc output voltage and the output current are indicated on a panel meter.

### SPECIFICATIONS

#### Dc Output

**Voltage:** 0 to 300 volts continuously adjustable, at 200 ma max.

**Regulation:** No load to full load, 0.1 volt; 0.75-volt change for  $\pm 10\%$  change in line voltage.

#### Bias Output

**Voltage:** -150 volts dc fixed, at 5 ma max.

**Regulation:** No load to full load, 0.5 volt; 2-volt max change for  $\pm 10\%$  change in line voltage.

**Unregulated Ac Voltage:** 2 circuits, each 6.3 volts nominal, at 5 amperes.

**Meter Accuracy:** Voltage, 2%; current, 5%.

**120-Cycle Ripple:** Less than one millivolt.

**Internal Impedance:** Approximately 0.3 ohm +2  $\mu$ h shunted by 4  $\mu$ f.

**Tube Complement:** Two each 6AV5-GA, 5727; one each 12AT7, 6AN8, 6626, 5651, 6BZ7.

**Power Input:** 105 to 125 volts, 60 cps; power consumption is 250 watts at full load.

**Accessories Supplied:** Adaptor plug, attached power cord, spare fuses.

**Dimensions:** Width 9 $\frac{1}{2}$ , height 5 $\frac{1}{4}$  inches (245 by 135 mm); depth behind panel 8 $\frac{1}{4}$  inches (210 mm).

**Net Weight:** 15 pounds (6.8 kg).

For a more complete description of this instrument, refer to the *General Radio Experimenter*, Volume 33, No. 3, March, 1959.

TYPE		CODE WORD	PRICE
1205-B	Adjustable Regulated Power Supply.....	APPLY	\$290.00
480-P4U2	Relay-Rack Adaptor Panel.....	UNIPANBOLT	11.00

PATENT NOTICE. See Notes 15 and 21, page viii.



Type 1203-B



Type 1201-B

### UNIT POWER SUPPLIES

Unit Power Supplies provide plate and heater power for Unit Oscillators (pages 108, and 110-113), Unit Amplifier (page 64), Unit Null Detector (page 58), Unit Pulser (page 115), and Unit Time/Frequency Calibrator (page 82).

#### Two models are available:

**TYPE 1203-B Unit Power Supply** — a general-purpose unregulated 300-volt supply.

**TYPE 1201-B Unit Regulated Power Supply** — a general-purpose regulated supply to minimize the effects of line-voltage fluctuations on oscillator amplitude and frequency, amplifier hum level, or pulse-generator jitter.

### SPECIFICATIONS

#### TYPE 1203-B

**Output:** Dc, 380 volts open circuit, 300 volts at 50 ma, all  $\pm 5\%$  for 115-volt input; ac, 6.3 volts, 3 amp.

**120-Cycle Ripple:** Less than 80 millivolts.

**Tube Complement:** One 6X4.

**Input:** 105 to 125 volts, 50 to 60 cps, 50 watts. Three-wire power cord is permanently attached. Can also be operated from a 400-cycle supply for applications where a 400-cycle 6.3-volt supply can be tolerated.

**Accessories Supplied:** Output plug for connection to equipment other than Unit Instruments, spare fuses.

**Mounting:** Aluminum panel and cabinet.

**Dimensions:** Width 5, height  $5\frac{3}{4}$ , depth  $6\frac{1}{4}$  inches (130 by 150 by 160 mm).

**Net Weight:** 5 pounds (2.3 kg).

#### TYPE 1201-B

**Output:** Dc, 300 volts  $\pm 1\%$ , regulated to 0.25%, 70 ma, max; ac, 6.3 volts, unregulated, 4 amp.

**120-Cycle Ripple:** Less than one millivolt.

**Tube Complement:** One each 12AX7, 6AV5GA, 5651, 12AT7, 6AN8.

**Input:** 105 to 125 volts, 50 to 60 cps, 90 watts. Three-wire power cord is permanently attached. Can also be operated from a 400-cycle supply for applications where a 400-cycle 6.3-volt supply can be tolerated.

**Accessories Supplied:** Output plug for connection to equipment other than Unit Instruments, spare fuses.

**Mounting:** Aluminum panel and cabinet.

**Dimensions:** Width 5, height  $5\frac{3}{4}$ , depth  $6\frac{1}{4}$  inches (130 by 150 by 160 mm).

**Net Weight:** 6 pounds (2.8 kg).

TYPE		CODE WORD	PRICE
1203-B	Unit Power Supply, 105 to 125 volts.....	ALIVE	\$ 50.00
1203-BQ18	Unit Power Supply, 210 to 250 volts.....	ALIVERALLY	60.00
1201-B	Unit Regulated Power Supply, 105 to 125 volts	ASSET	85.00
1201-BQ18	Unit Regulated Power Supply, 210 to 250 volts	ASSETRALLY	100.00
480-P4U1	Relay-Rack Adapter Panel.....	UNIPANARCH	11.00

### BATTERY-REPLACEMENT POWER SUPPLIES

**TYPE 1261-A POWER SUPPLY:** For use in place of BA48 (or 6TA60) battery in the TYPE 1550-A Octave-Band Analyzer. This power supply uses one 6H6 tube and two Burgess UNI-Cell No. 2 or Eveready No. 950 batteries. A TYPE CAP-22 Three-Wire Power Cord is supplied.

**TYPE 1262-B POWER SUPPLY:** Attaches to the TYPE 1551-C Sound-Level Meter to provide plate and filament power for laboratory use. The TYPE 1262-B Power Supply uses selenium rectifiers and RC filters.

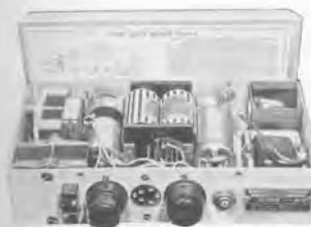

TYPE	VOLTS	FREQUENCY CPS	WATTS	FILAMENT SUPPLY VOLTS	MA	PLATE SUPPLY VOLTS	MA	DIMENSIONS INCHES*	NET WEIGHT	CODE WORD	PRICE
1261-A	105-125	40 to 400	10	1.5 or 3	50	133	0	10 X 5 X 2 1/4	7 3/4 lb	NUTTY	\$130.00
	or 210-250					63	8 max		(3.6 kg)		
1262-B	105-125	50 to 400	2	#1	1.2	40	75	5 X 7 1/4 X 3 3/8	2 1/2 lb	MAYOR	95.00
	or 210-250			#2	1.2	20	55		3.3		

\* To convert inches to mm, multiply by 25.4.





### TYPE 1263-B AMPLITUDE-REGULATING POWER SUPPLY

**USES:** In most measurements using radio-frequency oscillators, it is desirable to maintain a constant applied voltage as the frequency is varied. The TYPE 1263-B Amplitude-Regulating Power Supply automatically maintains the output of General Radio vhf and uhf oscillators at a preset value in spite of incidental amplitude variations which occur both with supply-voltage variations and with changes in oscillator frequency.

Owing to its very-high-speed response, the TYPE 1263-B is particularly useful when the oscillator dial is mechanically driven by a TYPE 1750-A Sweep Drive for oscillographic display of amplitude-frequency characteristics.

This power supply will modulate a Unit Oscillator with 1-kc square waves, thus eliminating incidental fm and permits the use of an untuned detector with a sensitive audio amplifier. Regulation of average output level is maintained in this mode of operation so that swept measurements at very low rf levels can be made.

**DESCRIPTION:** The TYPE 1263-B Amplitude-Regulating Power Supply compares the dc potential developed by the oscillator output

rectifier with an adjustable dc reference potential in a feedback system. A rapid correction is applied to the plate-current supply of the oscillator to hold the oscillator output to a preset level. Rf blanking can be accomplished by shorting of the reference potential with an external contactor.

For 1-kc modulation a multivibrator and RC low-pass input filter are switched into the power-supply circuit. The voltage regulated is then the average value of the square-wave envelope. An external synchronous detector, useful for maintaining a high signal-to-noise ratio in low-level measurements, may be gated from a voltage provided.

#### FEATURES:

- Provides constant oscillator output within  $\pm 5\%$  including errors from oscillator harmonics below 500 Mc (up to 2000 Mc with suitable low-pass filters) with variations in frequency, load, and line voltage.
- Provides 1-kc square-wave modulation from an internal generator.
- With an external TYPE 874-VR Voltmeter Rectifier, the built-in, peak-responding meter indicates rms oscillator output voltage.

#### SPECIFICATIONS

**Rf Output Voltage:** 0.2 to 2.0 volts behind 50 ohms for any recommended oscillator (see below), and a TYPE 874-VR Voltmeter Rectifier. With 1-kc square-wave modulation, 0.2 to 1.0 volt behind 50 ohms.

**Rf Output Regulation:** Below 500 Mc, rf output of recommended Unit Oscillators is held to within  $\pm 5\%$  including the effects of harmonics. This regulation can be attained up to 2000 Mc if proper low-pass rf filters (see page 45) are used and a correction applied for the output-rectifier frequency characteristic.

#### Modulation

**Frequency:** 1-kc square-wave, adjustable  $\pm 5\%$ , stable

to within 5 cps over the rated range of line voltage.

**Duty Ratio:** 0.5 to 0.53, adjustable to compensate for oscillator starting delay.

**Rise and Decay Times:** 50  $\mu$ sec each.

**Overshoot:** None.

**Ramp-off:** Less than 0.5%.

**Gate Voltage:** Synchronized with "off" interval of modulation, exceeds 1 volt into the recommended load of 30 k $\Omega$  shunted by 300 pf. Rise and decay times are less than 50  $\mu$ sec each. Gate output during "on" interval of modulation is less than .01 volt.

**Plate Supply Output:** 0 to 300 volts at 30 ma.





**Heater Supply Output:** 6 v  $\pm 10\%$  at 0.5 amp, 5.4 v  $\pm 10\%$  at 0.7 amp.

**Response Time:** For a 2-to-1 step variation in oscillator output, correction is completed within 0.5 msec with cw operation, 50 msec with 1-kc modulation. Recovery time after blanking is less than 2 msec with cw operation, less than 200 msec with 1-kc square-wave modulation.

**Hum and Noise:** Peak residual hum and noise modulation is less than  $\pm 0.3\%$  on cw; less than  $\pm 3\%$  with 1-kc square-wave modulation.

**Output Voltmeter:** Internal standardizing circuit is provided. Accuracy after standardization is better than  $\pm 10\%$  of indication when a correction is applied for rectifier characteristic at extremely high frequencies.

**Tube Complement:** Four 12AX7, one each 5963, 6V6GT, 0A2.

**Power Input:** 105 to 125 (or 210 to 250) volts, 50 to 60 cps, 55 watts maximum, at full load.

**Accessories Supplied:** TYPE CAP-22 Three-Wire Power

Cord, connector cable for modulation jack on oscillator, spare fuses.

**Other Accessories Required:** TYPE S74-VR Voltmeter Rectifier (page 50), TYPE S74-R22 Patch Cord (page 44) for connecting output rectifier, and TYPE S74-T for monitoring oscilloscope connection in sweeping applications.

**Recommended Oscillators:** (pages 108 to 112): TYPE 1215-B (50 to 250 Mc), TYPE 1209-BL (180 to 600 Mc), TYPE 1209-B (250 to 920 Mc), TYPE 1361-A (450 to 1050 Mc), TYPE 1218-A (900 to 2000 Mc), and for cw operation only TYPE 1211-B (0.5 to 50 Mc).

**Other Accessories Available:** The TYPE 1750-A Sweep Drive (page 145) is recommended for automatic operation. Coaxial Cables, connectors, attenuators, filters, and adaptors are listed on pages 40 to 48. For relay-rack adaptor panels see specifications for Type 1264-A, page 140.

**Mounting:** Aluminum panel and cabinet.

**Dimensions:** Width 8, height 7, depth 9  $\frac{1}{4}$  inches (205 by 180 by 235 mm), over-all.

**Net Weight:** 14  $\frac{1}{2}$  pounds (6.6 kg).

TYPE		CODE WORD	PRICE
1263-B	Amplitude-Regulating Power Supply.....	GAVOT	\$355.00

The previous model of the Amplitude-Regulating Power Supply, TYPE 1263-A, is still available. This model does not provide 1-kc square-wave modulation. The TYPE 1263-A is priced at \$305.00; code word is SALON.



## TYPE 1264-A MODULATING POWER SUPPLY

**USES:** The TYPE 1264-A Modulating Power Supply is used primarily to produce 100% pulse and square-wave modulation of vhf and uhf Unit Oscillators. In addition to its use as a modulator, this power supply can be used as an adjustable, regulated supply for the oscillator plate and a source of unregulated heater power.

Although the TYPE 1264-A was designed especially as a companion to the new TYPE 1361-A UHF Oscillator (450 to 1050 Mc), accessory adaptor cables permit use of this power supply with many other General Radio oscillators (see specifications).

**DESCRIPTION:** The TYPE 1264-A comprises an electronically regulated, adjustable-output, high-voltage, dc supply, a dc-coupled, series-type power modulator driven by a Schmitt trigger circuit, and a 1-kc multivibrator. A switch permits selection of cw, standby (only heaters energized), 1-kc square-wave modulated (internally generated), or externally modulated operation. Independent panel controls vary the regulated supply voltage for cw operation and the modulator amplitude for square-wave and pulse operation. Controls are also provided to adjust the frequency of the internal 1-kc multivibrator and the duty



Type 1264-A Modulating Power Supply assembled with a Type 1361-A Oscillator and Type 480-P416 Panel Extensions for relay-rack mounting.

ratio to produce a true square wave.

The input trigger circuit accepts single or multiple positive pulses, which are reproduced at the modulator output. It also accepts square waves at rates up to 100 kc, or sine waves up to 50 kc, from any 20-volt source such as a TYPE 1217-A Unit Pulser or TYPE 1210-C Unit RC Oscillator, and produces square waves at the modulator output. No adjustment of triggering is necessary. The stable 1-ke multivibrator provides ideal square-wave

modulation for use with sharply selective amplifiers following the signal detector.

### FEATURES:

- Clean, stable, high-level output pulses.
- Stable internal 1-ke square-wave generator.
- Synchronization to wide range of input signals.
- With an external pulse source, repetition rates from 20 cps to 100 kc are available.
- Adjustable, well-regulated dc output for cw operation.

### SPECIFICATIONS

#### Regulated Dc Output (Unmodulated)

**Voltage:** Adjustable from 200 to 300 volts.  
**Current:** 50 ma maximum.

**Stability:** Output voltage at any rated load will change less than 0.5 volt for  $\pm 10\%$  line-voltage change.

**Ripple:** Less than 1 mv rms with B- grounded; less than 5 mv rms with B+ grounded.

#### Heater Power Output (Unregulated)

**Voltage:** 6.3 volts ac.  
**Current:** 2.1 amp maximum.

#### Square-Wave Output (Internally Generated)

**Amplitude:** Adjustable from approximately 160 to 210 volts.

**Frequency:** Adjustable from 850 to 1150 cps.

**Stability:** Frequency will change less than 0.5% for  $\pm 10\%$  line-voltage change.

**Duty Ratio:** 0.5, adjustable  $\pm 5\%$ .

#### Square-Wave Output (from External Sine-Wave Generator)

**Amplitude:** Adjustable from approximately 160 to 210 volts.

**Driver Requirements:** 20 to 50 v rms, 20 to 50,000 cps.

#### Pulse Output (Externally Generated)

**Amplitude:** Adjustable from approximately 160 to 210 volts.

**Duration (between half-amplitude points):** 1.5  $\mu$ sec to square waves; duration determined by external generator.

**Rise and Decay Times (between 10% and 90% of maximum amplitude):** Less than 1.5  $\mu$ sec when driving a load capacitance of 300 pf in shunt with a resistance of 15,000 ohms or less.

**Ramp-off:** None.

**Overshoot:** Less than 5%.

**Driver Requirements:** 20 to 50 volts peak, positive polarity, 20 to 100,000 pulses per second.

**Tube Complement:** Three 5965, two 5763, one each 6AN8, 6AV5GA, 5651, 5963.

**Power Input:** 105 to 125 (or 210 to 250) volts, 50 to 1000 cps, 85 watts.

**Accessories Supplied:** TYPE CAP-22 Three-Wire Power Cord, connector plug.

**Recommended Oscillators:** TYPE 1361-A (450 to 1050 Mc); TYPES 1215-B (50 to 250 Mc), 1209-B (250 to 920 Mc), 1209-BL (180 to 600 Mc), and 1218-A (900 to 2000 Mc) (pages 109 to 112).

**Other Accessories Available:** TYPE 1264-P1 Adaptor Cable to connect to TYPES 1209-B, 1209-BL, and 1215-B Unit Oscillators; TYPE 1264-P2 Adaptor Cable to connect to TYPE 1218-A Unit Oscillator; TYPE 480-P408 Panel Extensions for relay-rack mounting; TYPE 480-P416 Panel Extensions for rack mounting with the TYPE 1361-A UHF Oscillator.

**Dimensions:** Width 8, height 7, depth 9  $\frac{1}{4}$  inches (205 by 180 by 235 mm).

**Net Weight:** 12 pounds (5.5 kg).

TYPE		CODE WORD	PRICE
1264-A	Modulating Power Supply	MODUL	\$285.00
1264-P1	Adaptor Cable	MODULCABLE	15.00
1264-P2	Adaptor Cable	MODULADAPT	8.50
480-P408	Panel Extensions (pair)	EXPANELJAG	8.00Pair
480-P416	Panel Extensions (pair)	EXPANELNIT	6.00Pair

# RECORDER AND SWEEP DRIVES



The automatic display of data on oscilloscopes and graphic recorders has become an important factor in the conservation of engineering manpower and time. In the following pages are listed two types of instruments for data-display techniques: (1) a graphic-level recorder for frequencies up to 200 kc and (2) a group of mechanical dial drives, which adapt manual instruments for automatic sweep operation.

## ► RECORDER

The TYPE 1521-A Graphic Level Recorder will plot automatically the frequency response of electrical and electroacoustic devices as well as the absolute level, as a function of time. It can also be used as a linear dc recorder.

## ► MECHANICAL DRIVES

The sweep drives and dial drives convert

manually operated equipment for sweep operation and provide an economical means for automatic data display.

## ► DIAL DRIVES

The dial drives described in this section are mechanical accessories for already existing instruments that will convert them to automatic operation. Good quality, manually adjustable instruments of most kinds can be easily adapted for automatic display work. The vastly improved efficiency of the converted instrument will pay for the conversion many times over.

Driven by a synchronous motor, each model is restricted to one speed. They can be set to cover different angles of rotation and they reverse direction automatically to yield an oscillating motion.



## TYPE 1521-A GRAPHIC LEVEL RECORDER

**USES:** The Graphic Level Recorder plots linearly in decibels the rms level of ac voltages from 20 cps to 200 kc. It produces permanent ink records of the response of electrical or electroacoustic devices and systems as a function of either frequency or time. Owing to the high stability of its reference voltage and amplifier gain, it can be used as a recorder of absolute level.

### *Amplitude-Frequency Plotting*

For frequency-characteristic measurements, the paper drive can be coupled by means of drive and link units (see price list) to the frequency-control shaft of an oscillator or analyzer for completely automatic recording.

The combination of the recorder and the TYPE 1304-B Beat-Frequency Audio Genera-

tor produces records having a true logarithmic frequency scale and is ideal for plotting frequency characteristics of analyzers, recording systems, networks, filters, and equalizers, as well as of loudspeakers, microphones, vibration pickups, and other transducers.

### *Acoustic Measurements*

The combination of the recorder and the TYPE 1554-A Sound and Vibration Analyzer makes possible automatic analysis of sound spectra, and response measurements on networks excited by white noise.

Used with the TYPE 1551 Sound-Level Meter, the recorder can plot sound levels over a wide dynamic range. For measurements of level as a function of time, the writing speed is sufficiently high for the measurement of rever-



beration time and other transient phenomena.

The wide range of paper speed facilitates long-period studies of the noise produced by traffic, office machinery, industrial processes and potential hearing-damage conditions, as well as of short-duration transients.

Accessory potentiometer units are available for a wide variety of scales for ac recording. They are supplemented by a linear potentiometer which converts the instrument from a level recorder to a general-purpose dc recorder.

**DESCRIPTION:** The TYPE 1521-A Graphic Level Recorder is a completely transistorized single-channel, servo-type recorder. It produces a strip-chart record with red ink on white paper, suitable for reproduction. The pen is attached to a coil which moves linearly over a 4-inch distance in a uniform magnetic field. A contact attached to the coil rides on a straight potentiometer which is the balancing element for the servo. The position of the contact is determined by the input signal, and the exponential potentiometer characteristic produces a linear db scale.

The detector circuit has, for all commonly encountered waveforms, a response that very closely approximates true rms.

The difference between the detector output and a one-volt reference derived from a Zener diode is amplified by a stable dc amplifier and used to position the coil which carries the potentiometer contact and pen. A velocity-feedback coil mounted on the drive-coil frame provides appropriate damping.

Careful design has made it possible to maintain both a high writing speed and the largest servo bandwidth consistent with a frequency response extending downward to 20 cps, without exceeding a 1-db overshoot. Writing speeds of approximately 1, 3, 10, and 20 inches per

second are selectable by a single switch without auxiliary adjustment of low-frequency cutoff or damping.

Changes of the recording range are easily accomplished by use of a 20-db or an 80-db potentiometer in place of the 40-db unit supplied as standard equipment. With the 80-db potentiometer the maximum writing speed becomes 300 db/second, making possible measurement of reverberation times as short as 0.3 second. The slow writing speeds are provided to filter out abrupt level variations, yielding a smoothed plot. Careful analysis and control of factors influencing dynamic behavior make possible this smoothing without loss of accuracy.

For dc recording the potentiometer, ac amplifier, and detector are removed from the circuit. The linear potentiometer, in this method of connection, provides a balancing voltage in series with the input voltage, and the combined voltage is balanced against the 1-volt reference. A single 0.8-volt range at a 1000-ohm input-impedance level makes the instrument interchangeable with the usual direct-writing strip-chart recorders.

### FEATURES:

- High input sensitivity.
- Calibrated in absolute level.
- Wide input frequency range.
- Fast writing speed with optimum ballistics.
- Simple to operate.
- RMS detector.
- Mechanical coupling available for driving oscillator or analyzer.
- Interchangeable logarithmic potentiometers.
- Easily converted to dc linear recorder.
- Completely transistorized.

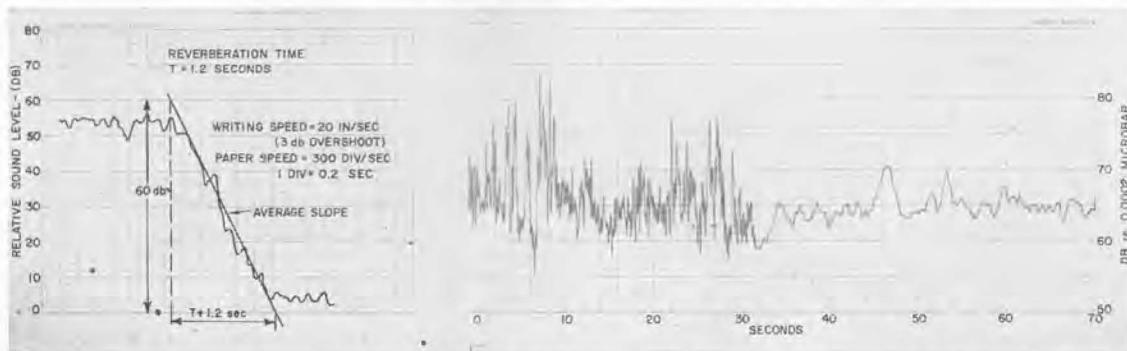

Chart record of reverberation time of auditorium excited by  $\frac{1}{3}$ -octave band of noise at 500 cps.

Record of noise level in a cafeteria with both fast and slow writing speeds and 40-db potentiometer.





## SPECIFICATIONS

**Input Frequency Range:** 20 cps to 200 kc, for level recording; dc recording (servo bandwidth), dc to 10 cps.

**Input Range:** 0 to 40 db for level recording (20-db and 80-db potentiometers are also available); 0-0.8 volt (at 1000 ohms) full scale, for dc recording with zero input position adjustable over full scale.

**Accuracy:** Potentiometer, 1% of full-scale db value, recorder balances within 0.25% of full scale.

**Maximum Sensitivity:** 1 millivolt at 0 db for level recording; 0.8 volt full scale for dc recording.

**Input Attenuator:** 60 db in 10-db steps.

**Maximum Input Voltage:** 100 volts ac.

**Input Impedance:** 10,000 ohms for ac level recorder  
1000 ohms for dc recorder.

**Paper Speeds:** 2.5 inches per minute to 75 inches per minute. A slow-speed motor to provide speeds of 2.5 to 75 inches per hour is available as an accessory.

**Writing Speed:** 1, 3, 10, or 20 inches per second (approximately), with overshoot less than 1 db.

**Oscillator or Analyzer Drive:** Order Type 1521-P10 Drive Unit and appropriate Link Unit.

**External Dc Reference:** Internal terminals are provided for an external dc voltage, which can be substituted for the 1-volt internal dc reference. The recorder will operate properly over a 3:1 reference-voltage range (0.5

to 1.5 volts). If this reference voltage is derived from the source of energy in the system under test, variations of up to 3:1 in the source output can therefore be eliminated from the recording.

**Detector:** Quasi-rms; within 0.25 db of rms for multiple sine waves, square waves, or noise. Detector operating level is 1 volt.

**Chart:** 4-inch recording width on 5-inch paper. All charts have 8 major divisions, 40 total divisions on vertical scale.

**Transistor Complement:** Twelve TR1, four 2N321, three 2N176.

**Accessories Supplied:** 40-db potentiometer, spare fuses, power cord, 2 pens, 2-oz bottle of ink, 1 roll of CTP-505 paper, dropper for filling pen; adaptor cable for Type 1551-B and-C Sound-Level Meters.

**Accessories Available:** Potentiometers, charts, ink, slow-speed motors, drive and link units, as listed in price table.

**Power Supply:** 105 to 125 (or 210 to 250) volts, 60 cps, 35 watts. 50-cycle models are available; see price list below.

**Dimensions:** Width 19, height 9, depth 14 1/4 inches (485 by 229 by 362 mm), over-all.

**Net Weight:** 50 pounds (23 kg).

TYPE	MOUNTING	SUPPLY FREQUENCY	PAPER SPEED	CODE WORD	PRICE
1521-AR	Rack	60 cps	2.5-75 in./min	AGENT	\$995.00
1521-AM	Bench	60 cps	2.5-75 in./min	ASTER	995.00
1521-ARQ1	Rack	50 cps	2.5-75 in./min	AGENTRABID	995.00
1521-AMQ1	Bench	50 cps	2.5-75 in./min	ASTERRABID	995.00

### POTENTIOMETERS

1521-P1	20 db	FACET	\$ 55.00
1521-P2*	40 db	AZURE	55.00
1521-P3	80 db	FELON	155.00
1521-P4	Linear	FAUNA	55.00

\*Supplied with Recorder.

### CHARTS

CTP-501	Calibrated 20 cps-20 kc, logarithmic, in 9 inches, repeating every 13 1/2 inches along time axis; for use with Type 1304-B Beat-Frequency Oscillator	LOGARCHART	\$2.30*
CTP-505	Linear time base, 1 division = 1/4 inch; for ac or dc records as a function of time	LINALCHART	2.30*
CTP-516	Calibrated 25-7500 cps in 1/3 decade segments, scale 2 1/4 inches long, spaced for continuous rotation of analyzer knob; for use with Type 760-B Sound Analyzer	SOUNDCHART	2.30*
CTP-554	Calibrated 25-25,000 cps along axis; for use with Type 1554-A Sound and Vibration Analyzer	ANNALCHART	2.30*

All charts are 5 inches wide and have 8 major divisions on a 4-inch vertical scale with 40 total divisions except CTP-501, which has 80 total divisions. Roll length 100 feet. All may be used with any potentiometer.

### INK (red)

1521-409	2-ounce bottle	INKAL	\$0.85*
1521-409-2	16-ounce bottle	INKER	3.00*

\*Subject to quantity discounts.

### MOTORS FOR LOWER CHART SPEED†

1521-P20	(60 cps) for paper speeds of 2.5-75 inches/hour	PASTY	\$52.50
1521-P22	(50 cps) for paper speeds of 2.5-75 inches/hour	PERIL	52.50

### DRIVE AND LINK UNITS FOR COUPLING TO OSCILLATOR AND ANALYZERS

1521-P10	Drive Unit to operate all link units	PUPIL	\$72.00
1521-P11	Link Unit for coupling to Type 1304-B or Type 1554-A with recorder mounted below	PRIOR	18.00
1521-P12	Link Unit for coupling to Type 760-B	PUPPY	18.00
1521-P14	Link Unit for coupling to Type 1304-B below recorder; (will also operate Type 1554-A above recorder)	PANIC	18.00

PATENT NOTICE. See Note 18, page viii.

†Recorder can be supplied with low-speed motor installed, at same price as with standard motor.





### TYPE 1750-A SWEEP DRIVE

FOR WIDE-RANGE AUTOMATIC DATA DISPLAY

**USES:** Measurements by sweep methods over wide frequency ranges are made possible and practical with the TYPE 1750-A Sweep Drive, which adapts manually operated equipment to sweep operation. It can be used in the display of any electrical quantity as a function of the shaft angle of the device being swept and can be adjusted to sweep, in reciprocating motion, any arc up to 300 degrees, at speeds up to 5 cycles per second. Its universal coupler attaches easily to any knob, dial, or shaft. Used in conjunction with Unit Oscillators, it makes available an extremely versatile system of swept signal sources covering a frequency span from 20 cps to 2000 Mc. For a constant output over the entire frequency range of any one

of the Unit Oscillators, the TYPE 1263-B Amplitude-Regulating Power Supply is used. Deflection voltages for a cathode-ray oscilloscope are generated internally.

**DESCRIPTION:** The Sweep Drive is powered by a small motor, which drives the output shaft through an adjustable rack and a differential. Sweep frequency is determined by the motor speed, sweep arc is determined by the adjustable rack, and sweep center position is controlled through the differential. All adjustments can be made while the drive is in motion. An adjustable limit switch can be set to stop the drive when predetermined limits of motion of the driven shaft are exceeded.



General Radio Sweep Drive and Unit Oscillator used in the test of wide-band amplifiers.

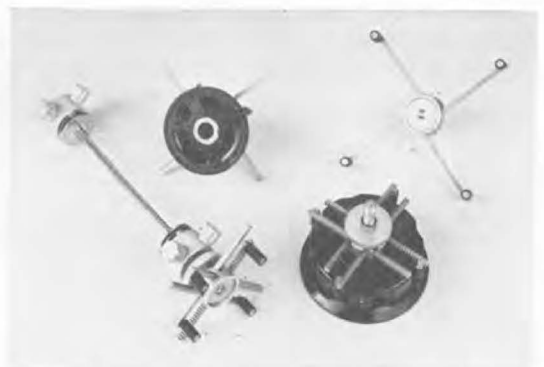

View of the coupling attachments furnished with the Sweep Drive. At left is the coupling shaft, to which has been attached the universal clutch. The other views show the clutch and the clutch attached to a knob.



An oscilloscope-deflection-voltage circuit provides a horizontal deflection voltage that is proportional to shaft angle. A blanking circuit is included to eliminate the oscilloscope return trace and produce a base line.

### FEATURES:

- Brings sweep techniques to the laboratory or production line at minimum cost.
- Can be attached to any dial, shaft, or knob.
- Adjustable while in motion.
- Generates horizontal deflection voltage proportional to shaft angle.

Characteristic of a television front-end tuner set to channel 7; sweep range is 160 to 200 Mc; vertical deflection is square law.

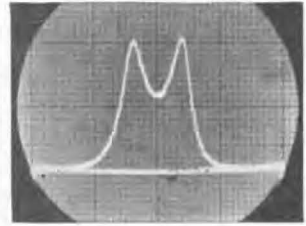

- Adjustable limit switches protect against exceeding preset limits of shaft travel.
- Provides a constant-output swept oscillator when used with Unit Oscillator and TYPE 1263-B Amplitude Regulating Power Supply.

### SPECIFICATIONS

#### Reciprocating Output Shaft

Center Position: Adjustable over 9-turn range.  
 Sweep Arc: Adjustable 30–300 degrees.  
 Torque: Rated max 24 ounce-inches. Will drive TYPES 1208-B, 1209-B, 1209-BL, 1210-C, 1211-B, 1215-B, 1218-A Unit Oscillators, TYPES 1300-A and 1304-B Beat-Frequency Oscillators, TYPES 1302-A, 1305-A, and 1330-A Oscillators, TYPE 1554-A Sound and Vibration Analyzer, TYPES 805-C, 1001-A, and 1021-A Standard-Signal Generators.  
 Sweep Speed: Adjustable 0.5–5 cycles per second. Moment of inertia limits the speed at which a load can be driven.  
 Height of Shaft: Adjustable, 2½–4⅞ inches over bench.

Flexible Coupling: 5¾ inches long. Couples to ¼- and ⅜-inch shafts; knobs and dials 1 to 4 inches in diameter. Continuously adjustable.  
 Limit Switch: Adjustable within 9 turns.  
 Sweep Voltage: 2.5 volts peak to peak, ungrounded.  
 Blanking: Shorting contact closed during clockwise rotation of driven shaft, ungrounded.  
 Accessories Supplied: Couplings, lubricant, spare fuses.  
 Input Power: 105–125 volts, 50–60 cps, 60 watts maximum. On 400-cycle supply, maximum sweep speed is reduced 25%. A 210- to 250-volt model also available.  
 Dimensions: Width 17½, height 9, depth 8¼ inches (445 by 230 by 210 mm) over-all.  
 Weight: 22½ pounds (10.5 kg).

TYPE		CODE WORD	PRICE
1750-A	Sweep Drive (115 volts, 50–60 cps) . . . . .	STUDY	\$470.00
1750-AQ18	Sweep Drive (230 volts, 50–60 cps) . . . . .	STUDYREPEL	505.00

### CONSTANT-AMPLITUDE SWEEPING SYSTEM

The TYPE 1263 Amplitude-Regulating Power Supply makes possible the maintenance of constant output amplitude from a Unit Oscillator as the frequency dial is rotated. For a complete constant-amplitude sweep system, order the items below, in addition to the Unit Oscillator and Sweep Drive.

For low-pass filters, attenuators, and other Type 874 accessories, see pages 40–50.

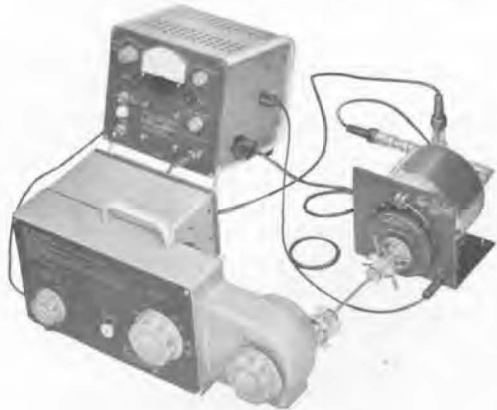

Type 1750-A Sweep Drive and the Type 1263-B Amplitude Regulating Power Supply set up to sweep a Type 1208-B Unit Oscillator, thus providing a constant sweep output over a frequency span of 250 Mc to 920 Mc. The equipment shown here is listed below, with the exception of the oscillator.

TYPE		PAGE
1263-B	Amplitude-Regulating Power Supply . . . . .	138
874-VR	Voltmeter Rectifier . . . . .	50
874-R22	Patch Cord . . . . .	44
874-T	Tee . . . . .	43
874-VQ	Voltmeter Detector* . . . . .	50
874-WM	50-ohm Termination* . . . . .	47

\*Used when 50-ohm systems are measured, to rectify the output of the network under test and to provide vertical deflection voltage.



### SYNCHRONOUS DIAL DRIVES

The TYPE 908-P and the TYPES 907-R and 908-R Dial Drives are an inexpensive means for adapting manually operated equipment to sweep operation. For equipment that uses TYPE 908 or 907 Dials (page 234) these drives can be installed directly in place of the vernier knob. Installation of these dials on other equip-

ment will adapt it for sweeping with these drives.

Each of these four drives is powered by a synchronous motor which reverses automatically when the drive encounters a mechanical stop. Adjustable stops that clamp on the dial are furnished; power switch and power cord are included.

#### TYPE 908-P DIAL DRIVES

These drives can be used on all TYPE 907 and 908 Precision Dials. No time base is included; the synchronous motor drive supplies the equivalent of a horizontal time calibration. The TYPE 908-P1 is intended

for use with a graphic recorder. The TYPE 908-P2 has a higher speed, and, although useful with the recorder, is particularly suitable for visual display on an oscilloscope with a long-persistence screen.

#### SPECIFICATIONS

**Speed:**

TYPE	PINION	908 DIAL	907 DIAL
908-P1	4 rpm	4/15 rpm or 225 sec/rev	4/10 rpm or 150 sec/rev
908-P2	30 rpm	2 rpm or 30 sec/rev	3 rpm or 20 sec/rev

On logarithmic frequency dials used on TYPES 1304 and 1330-A Oscillators, the sweep times are as follows: 908-P1 50 sec/frequency decade or 15 sec/octave. 908-P2 6 $\frac{2}{3}$  sec/frequency decade or 2 sec/octave.

These data are for 60-cycle operation. Multiply speeds by  $\frac{5}{6}$  for 50-cycle operation.

**Torque at Drive Shaft:** 908-P1 5 inch-ounces; 908-P2  $\frac{3}{8}$  inch-ounce. TYPE 908-P1 will drive the following oscillators: TYPES 1208-B, 1209-B, 1209-BL, 1211-B, 1215-B, 1210-C, 1330-A, and 1304-B. It will also drive the TYPE 1218-A, but the life of the drive is reduced.



TYPE 908-P2 will drive the TYPES 1209-B, 1209-BL, 1210-C, 1211-B, 1215-B, and 1304-B very satisfactorily. It is not recommended for use with TYPE 1208-B. It will not drive the TYPE 1218-A.

**Power Supply:** 105 to 125 volts, 50-60 cps.

**Dimensions:** 3 $\frac{3}{8}$  inches (92 mm) in diameter, 3 inches (76 mm) deep, over-all.

**Weight:** 1 $\frac{1}{4}$  lb (0.6 kg).

TYPE		CODE WORD	PRICE
908-P1	Synchronous Dial Drive .....	SYNDO	\$32.00
908-P2	Synchronous Dial Drive .....	SYNKA	32.00

### TYPE 907-R AND 908-R DIAL DRIVES

These dial drives will drive the dials of General Radio oscillators and other equipment and also supply a sweep voltage proportional to angle of rotation. They can be used in automatic plotting of frequency characteristics with an X-Y plotter or with an oscilloscope that amplifies dc and has a long-persistence screen.

One knob engages or disengages the motor, and the second knob permits manual setting at any point or direct manual drive. A dc voltage, applied to the potentiometer at binding posts, permits use with a wide range of dc output levels. Binding posts for the position-signal output are also provided.

#### SPECIFICATIONS

**Potentiometer:** 20,000 ohms. Maximum current: 10 ma. **Dimensions:** Depth 3 $\frac{7}{8}$  inches (100 mm); diameter, TYPE 907-R144, 4 inches (105 mm), TYPE 908-R96; 5 $\frac{1}{8}$  inches (150 mm).

**Net Weight:** TYPE 907-R144, 1 $\frac{3}{4}$  pounds (0.8 kg); TYPE 908-R96, 2 pounds (0.9 kg).

**Power Input:** 105-120 volts, 50-60 cps, 3 watts; speed data are for 60-cycle supply; for 50-cycle service, multiply by  $\frac{5}{6}$ .

The TYPE 907-R144 Dial Drive will drive the following GR instruments: TYPES 1210-C, 1208-B, 1209-B,

Type 908-R144 Dial Drive installed on a Type 1215-B Unit Oscillator.



1209-BL, 1554-A; the TYPE 908-R96 will drive TYPES 1211-B, 1215-B, 1304-B, 1305-A.

TYPE	USE WITH DIAL*	DIAL SPEED	RESOLUTION	CODE WORD	PRICE
907-R144	907	144°/min	0.4°	EDUCE	\$70.00
908-R96	908	96°/min	0.2°	EJECT	67.00

\*See page 234.

# RESISTORS



Because of accuracy of adjustment, long-time stability, low and uniform temperature coefficient, and relative immunity to ambient humidity conditions, the wire-wound resistor is the most suitable type for use as a laboratory standard at audio and low radio frequencies, as well as at dc. In the resistance range from a fraction of an ohm to about one megohm such resistors have been developed to a high state of refinement through improvements in resistive alloys and in design and manufacturing techniques. The wire-wound resistors in the form of fixed elements, individual decades, and decade assemblies ("decade boxes") described on the following pages are designed for ac use, as well as for dc.

Resistors designed for ac use differ from those intended for use only at direct current in that low series reactance and constancy of resistance as frequency is varied are important design objectives. Inevitably, resistors have capacitance and inductance associated with them, and these residual reactances become increasingly important as the frequency is raised, acting to change the terminal resistance from its low-frequency value.

For frequencies where the resistance and its associated residual reactances behave as lumped parameters, the equivalent circuit of a resistor can be represented as shown in Figure 1. The inductance  $L$  is the equivalent inductance in series with the resistance, while the capacitance  $C$  is the equivalent capacitance across the terminals of the resistor.

To analyze the behavior of the equivalent circuit as frequency is varied, it is necessary to differentiate clearly between the concepts of equivalent series and equivalent parallel circuits. The two-terminal circuit of Figure 1 can be described as an impedance  $R_s + jX_s$ , or as an admittance,  $G + jB$  ( $= \frac{1}{R_p} + \frac{1}{jX_p}$ ), wherein the parameters are a function of fre-

quency. This distinction between series and parallel components is more than a mathematical exercise — the use to which the resistor is put will frequently determine which component is of principal interest.

The expressions for the effective series resistance ( $R_s$ ) and the effective series reactance ( $X_s$ ) of Figure 1 are:

$$R_s = \frac{R}{\left[1 - \left(\frac{\omega}{\omega_0}\right)^2\right]^2 + (R\omega C)^2} \quad (1)$$

$$X_s = \frac{\omega \left\{ L \left[1 - \left(\frac{\omega}{\omega_0}\right)^2\right] - R^2 C \right\}}{\left[1 - \left(\frac{\omega}{\omega_0}\right)^2\right]^2 + (R\omega C)^2} \quad (2)$$

where  $\omega_0 = \frac{1}{\sqrt{LC}}$  and  $\left(\frac{\omega}{\omega_0}\right)^2 = \omega^2 LC$  (3)

The effective parallel components are given by:

$$G = \frac{1}{R_p} = \frac{1}{R \left[1 + \omega^2 \left(\frac{L}{R}\right)^2\right]} \quad (4)$$

$$B = -\frac{1}{X_p} = \omega C - \frac{1}{\omega L \left[1 + \frac{1}{\omega^2} \left(\frac{R}{L}\right)^2\right]} \quad (5)$$

At frequencies sufficiently low that terms involving the square of frequency are negligible, the resistor may be represented by a two-element network consisting of the dc resistance,  $R$ , in series with an inductance equal to  $L - R^2 C$  or in parallel with a capacitance

equal to  $C - \frac{L}{R^2}$ . Because of the presence of the

$R^2$  term in the equivalent reactive parameters, shunt capacitance is the dominating residual for high values of resistance, while for low values of resistance the series inductance invariably predominates. It is, in fact, a common fallacy to speak of "non-inductive" resistors in resistance values where shunt capacitance controls, and variations in inductance of the winding can have no significant effect on the reactive component.

In the simplified circuit described above, the effective parallel resistance of a resistor in which shunt capacitance dominates would be independent of frequency. Actually, other effects may cause the parallel resistance to

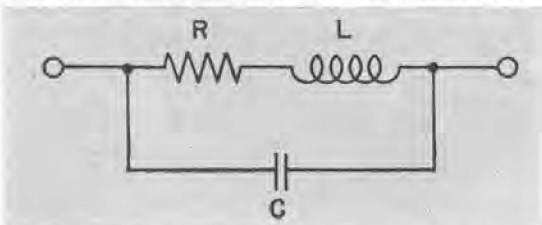

Figure 1. Equivalent circuit of a resistor showing the residual impedances associated with the resistance.

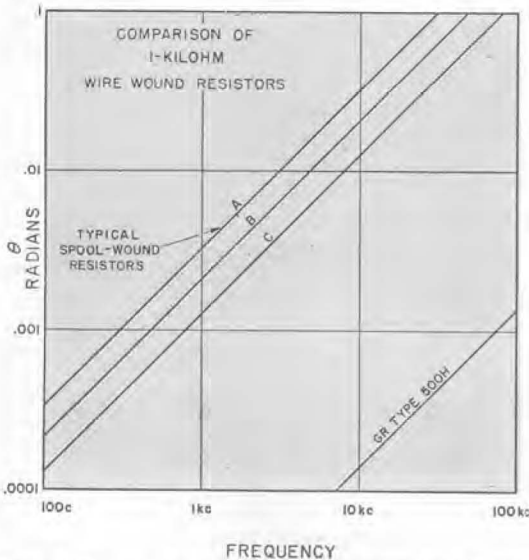

Figure 2. Phase angle as a function of frequency for a General Radio mica-card resistor and for three commercial wire-wound types.

decrease with frequency. For example, dielectric losses in the shunt capacitance,  $C$ , of Figure 1 are equivalent to a resistance

$$R_d = \frac{1}{D\omega C}$$

which decreases with increasing frequency and causes even the parallel resistance to decrease rapidly beyond a certain frequency. That portion of the shunt capacitance,  $C$ , which is distributed, causes a similar rapid decrease in resistance, even if its dielectric loss is negligible.

General Radio wire-wound resistance elements are designed to minimize inductance in low-resistance values and to minimize capacitance for high values of resistance. All units up through 100 ohms utilize a so-called Ayrton-Perry winding, in which each resistor consists of two parallel windings of opposed direction, so that the current flow in the two windings is in opposite directions. The external magnetic field, as a result, is effectively canceled so that, typically, the residual inductance of such a winding is of the order of 1% of the inductance of a corresponding single winding.

Elements having 200 ohms resistance or higher are unifilar-wound on their flat rectangular "cards." The inherent phase angle of these resistors is substantially lower than that obtained with so-called "non-inductive" spool-wound resistors commonly used commercially.

Wire-wound resistors of these types exhibit

a negligible frequency error in resistance up to about 500 kc, for values of resistance up to 500 ohms, and only moderate errors at one megacycle per second.

When assembled into decades, these resistors have added to their own residual impedances those of the switches, wiring, and cabinet. The equivalent circuit is then that of Figure 3, which represents a single decade of the 510 type. For assemblies of such decades in the TYPE 1432 Decade Resistor the same circuit is still valid. The incremental inductances of the several decades in the circuit are additive, but the capacitance is approximately that of the highest decade in use. Typical values of the residual impedances for the various types of General Radio resistors are given in the specifications for each type.

It should be noted that the effect of the residual reactance depends greatly upon the way the resistor is connected into a circuit. Reactances can often be tuned out, particularly in parallel circuits. This is a particularly important consideration with the higher-valued resistors of 10,000 ohms and above. When the resistor is used as a parallel-circuit element, the upper limit of frequency for a given error is some 10 times higher than for the series connection.

Probably the best known resistance alloy is manganin, used for over half a century in the manufacture of precision resistors. This old established alloy is still the most suitable for low values of resistance. For higher values, where small-diameter wire is required, more modern, proprietary alloys have been demonstrated to be superior. Such alloys are characterized by low temperature coefficients, substantially constant over a wide range of temperature. They have, in addition, negligible thermal emf against copper, high tensile strength, relative immunity to the effects of humidity and atmosphere, and are relatively insensitive to strain. These newer alloys are used in all GR precision resistors of 40 ohms and above.

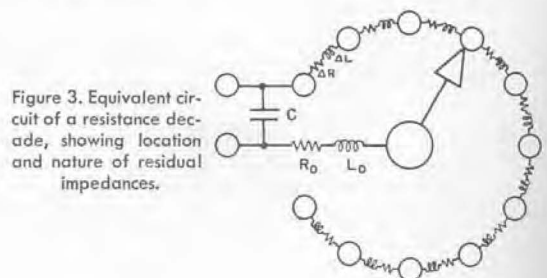
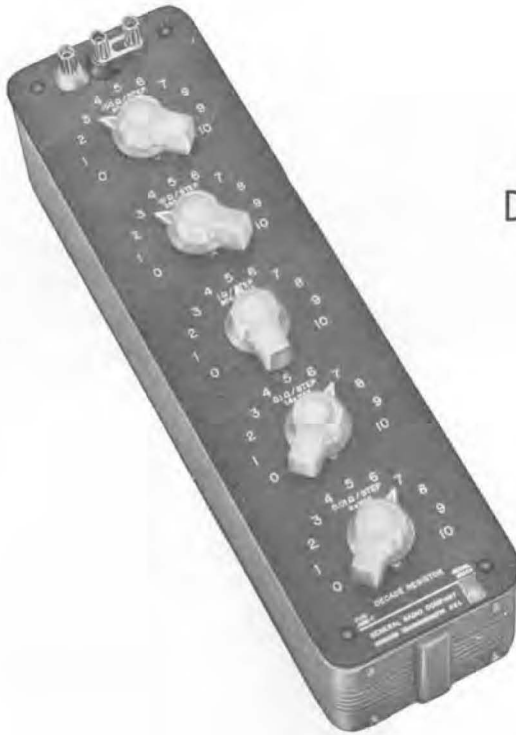

Figure 3. Equivalent circuit of a resistance decade, showing location and nature of residual impedances.



### TYPE 1432 DECADE RESISTOR

**USES:** Accurate decade resistors are necessary wherever electrical measurements are made. They are used in circuits where a wide range of resistance values is required or where variable dummy generator and load resistances are needed. The accuracy of TYPE 1432 Decade Resistors easily meets the requirements of these applications and also permits them to be used as laboratory standards and as ratio arms for direct- and alternating-current bridges.

Although designed primarily for direct-current and audio-frequency work, many of the models are useful well into the radio-frequency range.

General Radio decade resistors are the standard of the industry. They have been manufactured continuously since 1915 and have been constantly improved in accuracy, stability, and appearance through the use of the finest available materials and manufacturing techniques.

**DESCRIPTION:** The TYPE 1432 Decade Resistor is an assembly of TYPE 510 Decade-Resistance Units in a single cabinet. Mechanical as well as electrical shielding of the units is provided by the attractive aluminum cabinet and panel, which completely enclose both the resistance

units and switch contacts. The resistance elements have no electrical connection to the cabinet and panel, for which a separate shield terminal is provided.

Four-, five-, and six-dial decade assemblies are available. Each decade has eleven contact studs and ten resistance units, so that the dial values overlap. Positive detent mechanisms in conjunction with bar-type knobs permit the operator to sense the position of the switches without looking at the panel.

#### FEATURES:

- Low zero resistance — .001 ohm or less per decade.
- High accuracy — 0.05% for most decades.
- Low temperature coefficient of resistance.
- Negligible thermal emf to copper.
- Resistors are adjusted to specified values at their own terminals rather than at the box terminals, so that resistance *increments* are always correctly indicated.
- Residual reactances are small and are given in the specifications so that approximate frequency characteristics can be computed.



Interior view of Type 1432-Q Decade Resistor

### SPECIFICATIONS

**Accuracy of Adjustment:** All resistors are adjusted at dc within  $\pm 0.05\%$  of the stated value at their terminals, except the 1-ohm units, which are adjusted within  $\pm 0.15\%$ , the 0.1-ohm units, which are adjusted within  $\pm 0.5\%$ , and the .01-ohm units, which are adjusted to  $\pm 2\%$ . Resistance increments are accurate to these tolerances.

**Total Resistance at Terminals:** Sum of dial settings plus the zero resistance given below.

**Frequency Characteristics:** Similar to those of individual TYPE 510 Decade Resistance Units, modified by the increased series inductance,  $L_0$ , and shunt capacitance,  $C$ , due to the wiring and the presence of more than one decade in the assembly. At total resistance settings of approximately 1000 ohms or less, the frequency characteristic of any of these decade resistors is substantially the same as those shown for the TYPE 510 Decade-Resistance Units in the plot on page 152. At higher settings, shunt capacitance becomes the controlling factor, and the effective value of this capacitance depends upon the settings of the individual decades. See *Residual Impedances* below, and Figure 3, page 148.

**Residual Impedances:**

Zero Resistance ( $R_0$ ): .001 ohm or less per dial at dc; 0.04 ohms per dial at 1 Mc; proportional to square root of frequency at all frequencies above 100 kc.

Zero Inductance ( $L_0$ ): 0.10  $\mu$ h per dial.

Effective Shunt Capacitance ( $C$ ): This value is determined largely by the highest decade in use. With the

LOW terminal connected to shield, a value of 15 to 10 pf per decade may be assumed, counting decades down from the highest. Thus, if the third decade from the top is the highest resistance decade in circuit (i.e., not set at zero) the shunting terminal capacitance is 45 to 30 pf. If the highest decade in the assembly is in use, the effective capacitance is 15 to 10 pf, regardless of the settings of the lower-resistance decades.

**Temperature Coefficient of Resistance:** Less than  $\pm 0.002\%$  per degree Centigrade at room temperatures, except for the 0.1- and .01-ohm decades, where the box wiring will increase the over-all temperature coefficient.

**Type of Winding:** See specifications for TYPE 510 Decade-Resistance Units, page 151.

**Maximum Current:** See specifications for TYPE 510 Decade-Resistance Units, page 151. Values for 40° C rise are engraved on panels directly above switch knobs.

**Terminals:** Jack-top binding posts set on General Radio standard  $\frac{3}{4}$ -inch spacing. Shield terminal is provided.

**Mounting:** Aluminum panel and cabinet.

**Dimensions:** Width,  $4\frac{3}{8}$  inches (110 mm); height,  $4\frac{3}{4}$  inches (120 mm); length, 13 inches (330 mm) for 4-dial,  $15\frac{1}{4}$  inches (400 mm) for 5-dial box, and  $18\frac{1}{4}$  inches (470 mm) for 6-dial box.

**Net Weight:** TYPE 1432-J, K, L, Q, U, 5 pounds, 4 ounces (2.4 kg); TYPE 1432-M, N, P, T, 6 pounds, 5 ounces (2.9 kg); TYPE 1432-X, 7 pounds, 8 ounces (3.4 kg).

TYPE	RESISTANCE		NO. OF DIALS	TYPE 510 DECADES USED	CODE WORD	PRICE
	TOTAL	MULTIPLE OF				
1432-T	1111.1 ohms	0.01 ohm	5	AA, A, B, C, D	DEVIL	\$120.00
1432-U	111.1	0.01	4	AA, A, B, C	DEWIN	95.00
1432-K	1111	0.1	4	A, B, C, D	DEFER	98.00
1432-J	11,110	1.	4	B, C, D, E	DEBIT	107.00
1432-N	11,111	0.1	5	A, B, C, D, E	DEMON	124.00
1432-L	111,100	10.	4	C, D, E, F	DECAY	112.00
1432-M	111,110	1.	5	B, C, D, E, F	DEMIT	135.00
1432-Q	1,111,000	100.	4	D, E, F, G	DEPOT	125.00
1432-P	1,111,100	10.	5	C, D, E, F, G	DETER	150.00
1432-X	111,111	0.1	6	A, B, C, D, E, F	DOGMA	160.00







## TYPE 510 DECADE-RESISTANCE UNIT

**USES:** Because of their accuracy, compactness, and sturdy construction, the TYPE 510 Decade-Resistance Units are ideal for assembly into production test instruments, bridges, and other experimental and permanent equipment. They are particularly useful in applications where only one or two decades are needed, or where a TYPE 1432 Decade Resistor cannot be mounted conveniently. In many cases the use of these units will release for general laboratory work relatively more expensive decade resistors that would otherwise be tied up for long periods of time in experimental equipment.

**DESCRIPTION:** Winding methods are chosen to reduce the effects of residual reactances. The 1- and 10-ohm steps are Ayrton-Perry wound on molded phenolic forms especially shaped and heat treated to minimize aging effects. The 100-ohm steps are Ayrton-Perry wound on a form of silicon-fiberglass laminate. The 0.01- and 0.1-ohm steps are straight wire and hairpin-shaped ribbon, respectively, while the 1000-, 10,000-, and 100,000-ohm steps are unifilar wound on thin mica cards.

Each individual resistor is adjusted to be accurate within its specified tolerance at its terminals, so that resistance increments are accurate to that tolerance.

Each decade is enclosed in an aluminum shield, and a knob and etched-metal dial plate are supplied. The mechanical assembly is also available complete with shield, blank dial plate, switch stops, and knob, but without resistors, as the TYPE 510-P3 and -P3L Switches.

**FEATURES:**

- High accuracy —  $\pm 0.05\%$  per step for most units.
- Excellent stability — newly developed stable resistance alloys, with final resistance adjustment after artificial aging at high temperatures above normal operating temperatures.
- Good frequency characteristics — most TYPE 510 Decades can be used at frequencies as high as several hundred kilocycles, as well as at dc.
- Low temperature coefficient.
- Negligible thermal emf to copper.
- Unaffected by high humidity — even the high resistance units can be exposed to high humidity for long periods of time without significant permanent change in resistance.

**SPECIFICATIONS**

**Resistance:** See table on next page.

**Accuracy of Adjustment:** Each of the 10 resistors in each decade is adjusted to be accurate at its terminals within the tolerances given in Table I. Resistance increments are accurate to this same tolerance.

**Total Resistance:** The resistance at the decade terminals is the sum of the switch resistance (see below) and that indicated by the switch setting.

**Maximum Current:** See Table I below. Maximum current is engraved on the dial plate supplied with each decade.

**Frequency Characteristics:** The equivalent circuit of a decade resistance unit is shown on page 148. The values of the residual impedances are listed in Table I.

The accompanying plot shows the maximum percentage change in effective series resistance of seven decades as a function of frequency. For low-resistance decades the error is due almost entirely to skin effect and is independent of switch setting, while for the high-resistance units, the error is due almost entirely to the shunt capacitance and its losses and is approximately proportional to the square of the resistance setting.

The high-resistance decades (Types 510-E, 510-F, and 510-G) are very commonly used as parallel resistance elements in resonant circuits, in which the shunt capacitance of the decades becomes part of the tuning capacitance. The parallel resistance changes by only a fraction, between a tenth and a hundredth, of the series-resistance change, depending on frequency and the insulating material in the switch.

**Switches:** Quadruple-leaf brushes bear on lubricated contact studs  $\frac{3}{8}$  inch in diameter. Both brushes and studs are of silver-bearing copper alloy. These brushes are bent so as not to be tangent to the arc of travel, thus avoiding cutting and affording a good wiping action. A cam-type detent is provided. There are eleven contact points (0 to 10 inclusive). The switch resistance is less than 0.001 ohm. The effective capacitance of the switch is of the order of 5 pf, with a dissipation factor of 0.06 at 1 kc for the standard cellulose-filled molded phenolic switch form, and 0.01 for the mica-filled phenolic form used in the TYPE 510-G Unit.

**Temperature Coefficient of Resistance:** Less than  $\pm 0.002\%$  per degree Centigrade at 23 C.



# RESISTORS

## DECADE



Maximum percentage change in series resistance as a function of frequency for Type 510 Decade-Resistance Units.

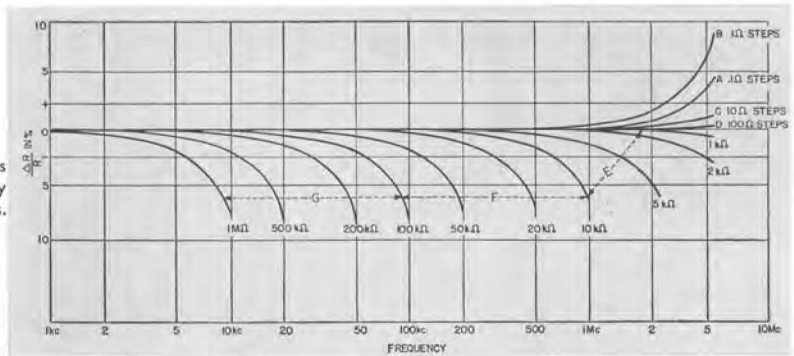

TABLE I

TYPE	RESISTANCE PER STEP (ΔR) OHMS	ACCURACY OF RESISTANCE INCREMENTS	MAXIMUM CURRENT 40° C RISE	POWER PER STEP WATTS	ΔL μh	C* pf	L <sub>0</sub> μh
510-AA	0.01	±2%	4 amp	.16	0.01	7.7-4.5	0.023
510-A	0.1	±0.5%	1.6 amp	.25	0.014	7.7-4.5	0.023
510-B	1	±0.15%	800 ma	.6	0.056	7.7-4.5	0.023
510-C	10	±0.05%	250 ma	.6	0.11	7.7-4.5	0.023
510-D	100	±0.05%	80 ma	.6	0.29	7.7-4.5	0.023
510-E	1000	±0.05%	23 ma	.5	3.3	7.7-4.5	0.023
510-F	10,000	±0.05%	7 ma	.5	9.5	7.7-4.5	0.023
510-G	100,000	±0.05%	2.3 ma	.5	—	7.7-4.5	0.023

\* The larger capacitance occurs at the lowest setting of the decade. The values given are for units without the shield cans in place. With the shield cans in place, the shunt capacitance is from 10 to 20 pf greater than indicated here, depending on whether the shield is tied to the switch or to the zero end of the decade.

**Terminals:** Soldering lugs are provided.

**Mounting:** Each decade is complete with dial plate and knob and can be mounted on any panel between 3/4 inch and 3/8 inch in thickness. A template is furnished with each unit. Thinner panels can be accommodated by the

use of shorter mounting screws.

**Dimensions:** Over-all diameter, 3 1/16 inches (78 mm); depth behind panel, 3 3/16 inches (85 mm).

**Net Weight:** TYPE 510 Units, 11 ounces (0.31 kg); TYPE 510-P Switches, 9 1/2 ounces (270 g).



Interior views of (left) Type 510-A, (center) Type 510-D, and (right) Type 510-E.

TYPE	RESISTANCE		CODE WORD	PRICE
	TOTAL	PER STEP		
510-AA	0.1 ohm	0.01 ohm	EASEL	\$19.50
510-A	1 ohm	0.1 ohm	ELATE	14.00
510-B	10 ohms	1 ohm	ELDER	21.50
510-C	100 ohms	10 ohms	ELEGY	21.50
510-D	1000 ohms	100 ohms	ELBOW	23.00
510-E	10,000 ohms	1000 ohms	ELECT	24.00
510-F	100,000 ohms	10,000 ohms	ELVAN	26.00
510-G	1,000,000 ohms	100,000 ohms	ENTER	35.00
510-R	100,000 ohms	Decade Steps, i.e., 0.1, 1, 10, 100, 1000, 10,000, 100,000 ohms	EAGER	27.00
510-P3	Switch only (Black Phenolic Frame) . . . . .		ENVOY	8.50
510-P3L	Switch only (Low-Loss Phenolic Frame) . . . . .		ESTOP	9.50





**TYPE 1450**  
**PRECISION**  
**DECADE ATTENUATOR**

**USES:** The TYPE 1450 Decade Attenuator is useful in power-level measurements, transmission-efficiency tests, and in gain or loss measurements on transistors, filters, amplifiers and similar equipment. It can also be used as a power-level control in circuits not equipped with other volume controls.

**DESCRIPTION:** The resistors used in each decade are mounted in compartments in an aluminum housing, which is completely shielded by the addition of aluminum covers. Each decade consists of four T-pads series-connected by cam-operated switches, arranged with positive detents. All cams are mounted on a control shaft which is provided with ball bearings. Each pad is completely shielded, and a shield is interposed between the input and output series elements of each pad. Each decade has

eleven positions, 0 to 10 inclusive, so the decades overlap.

**FEATURES:**

- Wide range of attenuation values in small steps.
- Accuracy is maintained even at low radio frequencies.
- Decade-type switches make the boxes convenient to use. There are no stops on the 0.1- and 1-db-per-step decades, facilitating quick return from full to zero attenuation when making adjustments. Switches are arranged for break-before-make operation to prevent "blasting" and meter damage. They can be adjusted for make-before-break operation if requested at time of ordering.
- An etched plate is attached to the case, indicating mismatch loss for terminations other than 600 ohms.

**SPECIFICATIONS**

**Attenuation Range:** 110 or 111 decibels in steps of 1 or 0.1 decibel, respectively.

**Terminal Impedance:** 600 ohms in either direction. An etched plate on the cabinet indicates the mismatch loss for other than 600-ohm circuits.

**Accuracy:** Each individual resistor is adjusted within  $\pm 0.25\%$  of its correct value. The low-frequency error in attenuation is less than  $\pm .02$  db  $\pm 0.25\%$  of indicated db setting plus a switch resistance error of .003 db (for TA) or .005 db (for TB), when the attenuator is terminated at both ends in a pure resistance of 600 ohms. For differences in attenuation between any two settings, the switch-resistance error virtually disappears.

**Frequency Discrimination:** Less than 0.1 db  $\pm 1\%$  of the indicated value at frequencies below 200 kc. For increments in attenuation, the 1% tolerance extends to approximately 1 Mc.

**Maximum Input Power:** 1 watt.

**Switches:** Cam-type switches are used with twelve positions covering 360°. The dials are numbered from 0 to 10 inclusive and the twelfth point is also connected to 0. Stops are provided in the switch mechanism for

the 100-db decade. No stops are provided to prevent complete rotation of the 10- and 1-db decades, but spacers, which are provided, can be used under the mounting screws to act as stops for the knob, if desired.

**Characteristic Impedance:** 600 ohms both directions. Either end can be used as input. One end must be terminated in 600 ohms.

**Mounting:** The decade units are mounted on an aluminum panel in a metal cabinet. Each decade is individually shielded, and all shields are connected to the panel and the "G" terminal. Relay-rack mounting is available on special order at an additional charge. See price list below.

**Terminals:** Jack-top binding posts with 3/4-inch spacing; common terminal grounded to chassis; ground terminal provided.

**Dimensions:** TYPE 1450-TA, width 10, height 5 3/4, depth 12 1/4 inches (255 by 145 by 315 mm) over-all; TYPE 1450-TB, width 12, height 5 3/4, depth 12 1/4 inches (305 by 145 by 315 mm), over-all.

**Net Weight:** 1450-TA, 10 3/4 pounds (4.9 kg); 1450-TB, 14 1/2 pounds (6.6 kg).

TYPE	RANGE	IMPEDANCE	TYPE OF SECTION	CODE WORD	PRICE
1450-TA	110 db in steps of 1 db . . .	600 ohms	T	NETWORKTAM	\$285.00
1450-TB	111 db in steps of 0.1 db . .	600 ohms	T	NETWORKTUB	390.00

For 19-inch relay-rack mounting add \$10.00 to price and add R to type number (TYPE 1450-TAR, -TBR).





### TYPE 1454 DECADE VOLTAGE DIVIDER

ACCURATE TO .04% OF INDICATED RATIO

**USES:** The TYPE 1454 Decade Voltage Dividers provide accurately known voltage ratios from .0001 to 1.000 for use in determining voltage transmission ratios by direct comparison or by null methods.

It is particularly valuable in linearity measurements and meter calibration.

Their high input impedance, high resolution, and high accuracy make them widely used laboratory accessories for both d-c and audio-frequency measurements.

**DESCRIPTION:** Four decade resistors of the 510-type are connected in a Kelvin-Varley circuit. The voltage drop in switches and wiring is compensated by a resistor so that accuracy is maintained down to the lowest settings.

#### FEATURES:

- High accuracy.
- Constant input resistance.
- Separate ground terminal provided.
- Negligible thermal emf.

#### SPECIFICATIONS

**Voltage Ratio:** 0.0001 to 1.0000 in steps of 0.0001.

**Accuracy:**  $\pm 0.04\%$  of indicated ratio for input voltages below 120 (350 on TYPE 1454-AH).

**Linearity:** Better than  $\pm 0.02\%$  of full-scale setting for any decade.

**Frequency Characteristics:** If the external capacitance across the output terminals of the TYPE 1454-A is less than 50 pf, the frequency error is less than 0.1% to 20 kc for any setting. For the TYPE 1454-AH, the frequency limit is 2 kc for the same capacitance.

**Input Resistance:** TYPE 1454-A, 10,000 ohms. TYPE 1454-AH, 100,000 ohms.

**Maximum Input Voltage:** For TYPE 1454-A, 230 volts rms (or dc) for 40° C rise of resistors of the input decade. Input voltage should be limited to 120 for maximum accuracy. At maximum rated voltage the total error can approach  $\pm 0.1\%$ . For TYPE 1454-AH, 700 volts rms, limited to 350 volts for maximum accuracy.

**Resistance Units:** TYPE 510 Decade Resistors.

**Temperature Coefficient:** Of each resistor, less than  $\pm 0.002\%$  per degree C. Since the voltage ratios are determined by resistors of similar construction, ambient temperature effects are very small.

**Terminals:** Jack-top binding posts with standard 3/4-inch spacing at input and output. A separate ground post is provided, so that the divider circuit can be used grounded or ungrounded, with the shield grounded.

**Output Resistance:** Varies with output setting, from zero to approximately 2700 ohms, depending primarily on the setting of the highest decade in use. Directions for accurate calculation of the output resistance are given in the instruction manual. Approximate values can be determined from the following table.

	.00	.01	.02	.03	.04	.05	.06	.07	.08	.09
0	0	189	356	501	624	725	804	861	896	909
.1	900	1069	1216	1341	1444	1525	1584	1621	1636	1629
.2	1600	1749	1876	1981	2064	2125	2164	2181	2176	2149
.3	2100	2229	2336	2421	2484	2525	2544	2541	2516	2469
.4	2400	2509	2596	2661	2704	2725	2724	2701	2656	2589
.5	2500	2589	2656	2701	2724	2725	2704	2661	2596	2509
.6	2400	2469	2516	2541	2544	2525	2484	2421	2336	2229
.7	2100	2149	2176	2181	2164	2125	2064	1981	1876	1749
.8	1600	1629	1636	1621	1584	1525	1444	1341	1216	1069
.9	900	909	896	861	804	725	624	501	356	189

**Mounting:** Aluminum panel and cabinet, finished in gray lacquer.

**Dimensions:** Length 15 3/4, width 5 1/4, height 5 inches (400 by 134 by 127 mm), over-all.

**Net Weight:** 7 1/4 pounds (3.3 kg).

TYPE		CODE WORD	PRICE
1454-A	Decade Voltage Divider (10,000 ohms).....	ABACK	\$150.00
1454-AH	Decade Voltage Divider (100,000 ohms).....	ABASH	150.00



### TYPE 500 RESISTOR

The TYPE 500 Resistors are particularly recommended as resistance standards for use in impedance bridges and as secondary standards for laboratory use. The plug-type terminals make them readily interchangeable in experimental equipment. Screw terminals are also supplied for more permanent installations. Resistors are similar in construction to those used in TYPE 510 decades (page 151).

This resistor is an accurately adjusted resistance unit wax-sealed in a phenolic case to exclude moisture and to provide protection from mechanical damage.

#### FEATURES:

- > Convenient and accurate.
- > Negligible thermal emf to copper.
- > Low temperature coefficient of resistance.
- > Excellent high-frequency characteristics.
- > Standard plug-in terminals.



#### SPECIFICATIONS

**Accuracy of Adjustment:**  $\pm 0.05\%$  at the terminals, except for the 1-ohm unit, which is adjusted within  $\pm 0.15\%$ .

**Frequency Characteristics:** Similar to those of the TYPE 510 Decade-Resistance Units for resistance values up to 600 ohms; somewhat better for higher resistances, because of the relatively small shunt capacitance of an isolated resistor.

**Maximum Power and Current:** All units will dissipate one watt for a temperature rise of 40° Centigrade. The value of current for this rise is given in the table below and is engraved on each unit.

**Temperature Coefficient:** Less than  $\pm 0.002\%$  per degree Centigrade at normal room temperature.

**Type of Winding:** Less than 500 ohms, Ayrton-Perry; 500 ohms and higher, unifilar on thin mica cards. TYPES 500-V, W, and X are made up of multiple mica cards in series.

**Terminals:** Both terminal screws and plugs are supplied. Each terminal stud is recessed as a jack to accommodate

a plug. Standard  $\frac{3}{4}$ -inch spacing is used. High terminal is marked H.

**Mounting:** Black molded phenolic case is used for all units having a resistance of less than 1000 ohms. For units having a resistance value of 1000 ohms or higher, a low-loss mica-filled phenolic case is used. Both types are sealed with a high-melting-point wax. TYPES 500-A through -V are in small case; TYPES 500-W and -X in large case.

**Dimensions:** See sketch. **Net Weight:** 2 ounces (60 g).

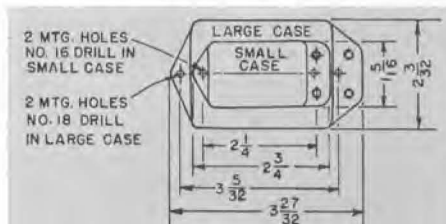

TYPE	RESISTANCE IN OHMS	MAXIMUM CURRENT	CODE WORD	PRICE
500-A	1	1.0 amp	RESISTBIRD	\$6.00
500-B	10	310 ma	RESISTDESK	6.00
500-K	20	220 ma	RESISTFILM	6.00
500-C	50	140 ma	RESISTFORD	6.00
500-D	100	100 ma	RESISTFROG	6.00
500-E	200	70 ma	RESISTGIRL	6.00
500-F	500	45 ma	RESISTGOAT	6.00
500-G	600	40 ma	RESISTGOOD	6.00
500-H	1000	30 ma	RESISTHYMN	6.00
500-L	2000	22 ma	RESISTBELL	6.00
500-M	5000	14 ma	RESISTPIPE	6.00
500-J	10,000	10 ma	RESISTMILK	6.00
500-R	20,000	7 ma	RESISTBARN	6.00
500-T	50,000	4.5 ma	RESISTGULL	6.00
500-U	100,000	3 ma	RESISTROLL	6.00
500-V	200,000	2.2 ma	RESISTVOTE	7.50
500-W	500,000	1.4 ma	RESISTWALL	17.00
500-X	1 Megohm	1.0 ma	RESISTHULL	27.00

**POTENTIOMETERS:** General Radio 970-series potentiometers are listed on page 231.



# STANDARD CAPACITORS

## Two-Terminal and Three-Terminal Types

Capacitors used as standards are of two general types: two-terminal and three-terminal. Most physical capacitors can be accurately represented by the three capacitances shown in Figure 1: the direct capacitance,  $C_{HL}$ , between the terminals  $H$  and  $L$  represents the capacitance between the plates of the capacitor, and the two terminal capacitances,  $C_{HG}$  and  $C_{LG}$ , represent the capacitances from the corresponding terminals and plates to the capacitor case, surrounding objects, and to ground, to which the case is connected either conductively or by its relatively high capacitance to ground.

Figure 1. Schematic diagram of a capacitor, showing the direct capacitance and its associated terminal capacitances.

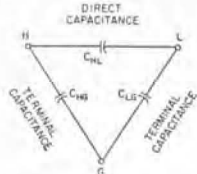

In the most commonly used two-terminal connection, the capacitor has the  $L$  and  $G$  terminals connected together, i.e., one set of plates is connected to the case. The terminal capacitance,  $C_{LG}$ , is thus shorted, and the total capacitance is the sum of  $C_{HL}$  and  $C_{HG}$ . Since one component of the terminal capacitance  $C_{HG}$  is the capacitance between the terminal and surrounding objects, the total capacitance can be changed by changes in the environment of the capacitor and particularly by the introduction of the wires required to make connection to the capacitor. The uncertainties in the calibrated value of a two-terminal capacitor can be of the order of tenths of a picofarad if the geometry, not only of the capacitor plates, but of the environment and of the connections is not defined and specified with sufficient precision. For capacitors of 100 pf and more, the capacitance is usually adequately defined for an accuracy of a few hundredths per cent if the terminals and method of connection used for calibration are specified. For smaller capacitances or for higher accuracy, the two-terminal capacitor is seldom practical and the three-terminal arrangement is preferred.\*

The three-terminal capacitor, represented by Figure 1, has connected to the  $G$  terminal a shield which completely surrounds at least one of the terminals ( $H$ ), its connecting wires, and its plates except for the area which produces the desired direct capacitance to the other terminal ( $L$ ). Changes in the environment and the connections can vary the terminal capacitances,  $C_{HG}$  and  $C_{LG}$ , but the direct capacitance  $C_{HL}$ —usually referred to simply as the capacitance of the three-terminal capacitor—is determined only by the internal geometry of the capacitor. This direct capacitance can be calibrated without the two-terminal connection errors by three-terminal measurement methods, such as guard circuits or transformer-ratio-arm bridges, which exclude the terminal capacitances. The capaci-

tance of a three-terminal capacitor can be made as small as desired, since the shield between terminals can be complete except for a suitably small aperture. The losses in the direct capacitance can also be made very low because the dielectric losses in the insulating materials can be made a part of the terminal impedances. A three-terminal capacitor can be easily connected as a two-terminal by shorting one terminal ( $L$ ) to the case ( $G$ ), but the two-terminal capacitance will exceed the calibrated three-terminal value ( $C_{HL}$ ) by at least the terminal capacitance  $C_{HG}$ .

## Capacitance:

Although the characteristics of the high-quality capacitors used as standards closely approach those of the ideal capacitor, the small deviations from ideal performance must be examined and evaluated to obtain high accuracy. The residual parameters which cause such deviations are shown in the lumped-constant, two-terminal equivalent circuit of Figure 2.  $R$  represents the metallic resistance in the leads, supports and plates;  $L$ , the series inductance of the leads and plates;  $C$ , the capacitance between the plates;  $C_k$  the capacitance of the supporting structure. The conductance,  $G$ , represents the dielectric losses in the supporting insulators, the losses in the air or solid dielectric between capacitor plates, and the dc leakage conductance.

The effective terminal capacitance  $C_o$  of the capacitor becomes greater than the electrostatic or zero-frequency capacitance  $C_o$  as the frequency increases because of the inductance  $L$ . When the frequency,  $f$ , is well below the resonance frequency  $f_o$  (defined by  $\omega_o^2 LC_o = 1$ ), the increase in capacitance is approximately

$$\frac{\Delta C}{C_o} \approx \omega^2 LC_o = \left(\frac{f}{f_o}\right)^2 \quad (1)$$

This change in capacitance with frequency for the capacitors described on the following pages is given either as a plot on logarithmic co-ordinates of the per cent increase,  $\Delta C/C_o$ , versus frequency or as a tabulation of the values of  $L$  or  $f_o$ . Since the inductance is largely concentrated in the leads and supports, it is nearly independent of the setting of a variable capacitor. With this information, the increase in capacitance at, for example, a frequency of 1 Mc can be computed from the calibrated value at 1 kc with high accuracy. For small increases, the accuracy may be greater than that of a measurement at 1 Mc because of the difficulties in determining the measurement errors produced by residuals in the connecting leads outside the capacitor.

The three-terminal capacitor has a similar increase in capacitance produced by inductance which can be determined in the same way from the resonance frequency,  $f_o$ . The lowest resonance is here determined not solely by the calibrated direct capacitance but also by the terminal capacitances, which may be much larger than the direct capacitances (see equivalent circuit of TYPE 1403 Capacitors, page 102).

When the capacitor has a solid dielectric, such as mica, there is another source of capacitance change with frequency. The capacitance increases at low frequencies as the result of dielectric absorption caused by interfacial polarization in the dielectric. The change in capacitance with frequency of a 1000-pf capacitor with mica dielectric is shown in Fig. 3. The dotted line slanting downward to the right represents the change in the dielectric constant of mica resulting from interfacial polarization; that slanting upward to the right shows the change in effective capacitance resulting from series inductance. The magnitude of the change at low fre-

\*John F. Hersh, "A Close Look at Connection Errors in Capacitance Measurements," *General Radio Experimenter*, 33, 7, July, 1959.

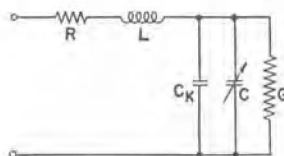

Figure 2. The equivalent circuit of a capacitor.

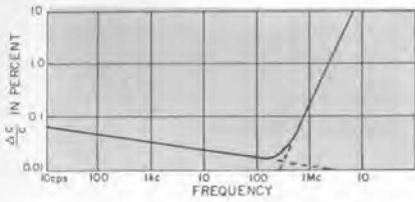
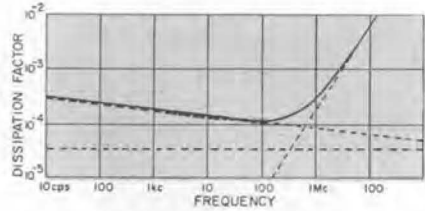

Figure 3. Variation with frequency of capacitance and dissipation factor for a mica capacitor.



quencies depends upon the dielectric material and is, for example, much smaller for polystyrene than for mica.

### Dissipation Factor:

The dissipation factor of a capacitor (defined on page 2) is determined by the losses represented in Figure 2 by  $R$  and  $G$ . The resistance  $R$  is not usually significant until the frequency is high enough for the skin effect to be essentially complete. At such frequencies the resistance varies as the square root of frequency and may be expressed as  $R_1 \sqrt{f}$ , where  $R_1$  is the resistance at one megacycle and  $f$  is the frequency in megacycles. The total dissipation factor at high frequencies is then

$$D = \frac{G}{\omega C} + R_1 \sqrt{f} \omega C \quad (2)$$

At low frequencies only the losses represented by  $G$  are important. The leakage conductance component of  $G$  is negligible at frequencies above a few cycles and is of importance only when the capacitor is used at dc for charge storage. The dominant components at audio frequencies are the dielectric losses in the insulating structure and in the dielectric material between the plates.

In the air capacitor the losses in the air dielectric and on the plate surfaces are negligible under conditions of moderate humidity and temperature. The loss is, therefore, largely in the insulating supports. When good-quality, low-loss materials, such as quartz, ceramics, and polystyrene are used for insulation, the conductance varies approximately linearly with frequency and the dissipation factor,  $D_k$ , of the supports is nearly constant with frequency. The total dissipation factor of an air capacitor, whose equivalent circuit is that of Figure 2, may be expressed at low frequencies as

$$D = \frac{G}{\omega(C + C_k)} = \frac{D_k C_k}{C + C_k}$$

When the capacitance  $C$  is variable, this  $D$  is then inversely proportional to the total terminal capacitance. Since the quantity  $D_k C_k$  is nearly independent of both frequency and capacitance setting, it is a convenient figure of merit for a variable capacitor.

In a capacitor with a solid dielectric the dominant component of the conductance  $G$  is the loss in the di-

electric, which varies with frequency. The resulting variation of  $D$  with frequency, shown for a mica capacitor in Figure 3, is the sum of three principal components: a constant dissipation factor caused by residual polarizations and shown by the horizontal dotted line; a loss produced by interfacial polarizations, which contributes the  $D$  shown by the dotted line slanting downward to the right; and an ohmic loss in the leads and plates, which results in a  $D$  proportional to the  $3/2$  power of frequency and is shown as the dotted line slanting upward to the right. The total dissipation factor has a minimum value at a frequency which varies inversely with capacitance and which ranges from 1 kc to 1 Mc for capacitance values from 1  $\mu$ f to 100 pf.

A properly designed air capacitor approaches very closely the ideal standard impedance, owing to its low temperature coefficient of capacitance, low losses, and high stability. The maximum practical capacitance for an air-dielectric unit is of the order of 1000 pf; larger sizes become unwieldy. For higher capacitances, solid dielectrics are used. High dielectric strength, low dielectric loss, and a high degree of dimensional stability make high-quality mica the best available solid dielectric for alternating-current standard capacitors. Silvered-mica sheets with soft metallic foil interposed between sheets insure intimate and stable contact between electrodes and the dielectric, as well as low series resistance.

For use at dc or extremely low frequencies, mica dielectric is at some disadvantage because of the relatively large increase in capacitance over the audio-frequency value. This increase is caused by interfacial polarizations having extremely long relaxation times.

Polystyrene exhibits the desirable property of having dielectric constant and dissipation factor very nearly invariant with frequency, the total increase in dielectric constant between the dc value and the 1-kc value being only a small fraction of a percent. (In contrast, mica may exhibit a rise of the order of 3%.)

The capacitors described in these pages include air-dielectric reference standards, both fixed and variable, both fixed and decade mica-dielectric standards, a decade with polystyrene dielectric, and other decades with polystyrene, mica, and paper dielectric.

TYPE	NAME	CAPACITANCE	PAGE
1422	Precision Capacitor (Two- and three-terminal, variable)	7 models, 1.1 to 1150 pf, full scale	158
1401	Standard Air Capacitor (Two-terminal, fixed)	100, 200, 500, 1000 pf	161
1403	Standard Air Capacitor (Three-terminal, fixed)	.01, 0.1, 1, 10, 100, 1000 pf	162
1409	Standard Capacitor (Fixed, mica)	.001 to 1 $\mu$ f in 10 models	163
1423	Standard Decade Capacitor	100 pf to 1.111 $\mu$ f	165
1424	Standard Polystyrene Decade Capacitor (Single decade)	10 $\mu$ f, full scale	164
1419	Decade Capacitor (3- and 4-dial boxes)	1 $\mu$ f, full scale	168
980	Decade Capacitor Unit	.001, .01, 0.1, and 1 $\mu$ f, full scale	166
505	Capacitor (Fixed, mica)	100 pf to 0.5 $\mu$ f in 12 models	170
1429	Fuel-Gage Tester	20 to 6220 pf	171



1422-D



1422-CB

### TYPE 1422 PRECISION CAPACITOR

**USES:** The TYPE 1422 Precision Capacitor, an improved version of the previous TYPE 722, is a stable and precise variable air capacitor intended for use as a standard of capacitance.

One of its most important applications is in ac bridge measurements, both as a built-in standard and as an external standard for substitution measurements. It is also used as a tuning capacitor in oscillators and frequency meters, and as a standard in electronic gauges, calibrators, and other instruments. Where highest accuracy and stability are important, it is the standard of the industry.

Both 2-terminal and 3-terminal models are available.

**DESCRIPTION:** The capacitor assembly is mounted in a cast frame, which gives the unit rigidity. The frame, spacers, stator rods, and rotor shaft are made of the best available alloys of aluminum, which combine the high mechanical strength of brass with the low weight of aluminum. The plates are also of aluminum, so that all parts have the same temperature coefficient of linear expansion.

A worm drive is used to obtain the desired high precision of setting. In order to avoid the slight eccentricity that may occur when a worm is mounted on a shaft, the shaft and the worm are accurately machined as one piece. The dial end of this worm shaft runs in a self-aligning ball bearing, while the other end is supported by an adjustable spring mounting. This spring mounting gives positive longitudi-

dinal anchoring to the worm shaft through the use of a pair of sealed self-lubricating preloaded ball bearings. Similar pairs of preloaded ball bearings, one pair clamped to the casting at the worm end, provide positive and invariant axial location for the main or rotor shaft. Electrical connection to the rotor is made by means of a silver-alloy brush bearing on a silver-overlay drum to assure a positive electrical contact.

The worm and worm wheel constituting the worm drive are high-accuracy precision components especially made for this purpose. Following the precision cutting operations, each pair is lapped in, each to the other, to remove the majority of the small unavoidable eccentricities in worm and worm wheel. This lapping process also enlarges the contact area and provides a more favorable surface for holding lubricant, thus also improving the smoothness and wear resistance of the drive.

Stator insulation in all models is a cross-linked thermosetting modified polystyrene having very low dielectric losses and very high insulation resistance. Even in humid atmospheres the standard insulation is satisfactory for electrometer uses. In the TYPES 1422-CC and -CD the insulation is in the form of plain and shouldered washers separating the brass stator plates. In all other models the insulation between the stator stack and the casting consists of washers or buttons having one flat and one spherical surface, the latter mating with a spherically counterbored hole in the



1422-D

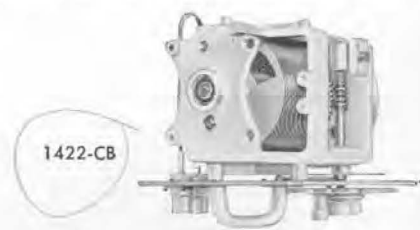

1422-CB





casting or separate support piece. Rotor insulation, when used (TYPES 1422-CB and -N), is grade L-4 steatite, silicone treated.

TYPE 1422-D is a two-section, two-terminal capacitor with a scale which is direct-reading in total capacitance at the terminals. It is generally useful as a variable capacitance standard at audio frequencies.

TYPE 1422-N is similar to the TYPE 1422-D high section but is intended for use at higher frequencies. To minimize residual inductance and resistance, the connections are made through ribbon leads to the center of the stator and to the center of the rotor through silver-alloy brushes bearing on a silver-overlay disc.

TYPES 1422-MD and -ME are two-section, two-terminal capacitors with scales reading the capacitance removed, i.e., the capacitance is maximum at the zero reading, and a reading of 300, for example, means the capacitance is 300 pf less than the zero capacitance. This scale is particularly convenient for substitution measurements.

TYPES 1422-CB, -CC, and -CD are three-terminal capacitors with shielded terminals for use in three-terminal measurements where a calibrated direct capacitance independent of terminal capacitances to ground and with very

low losses is needed and where an accurate variable capacitance of very small magnitude can be used. The TYPE 1422-CB is similar in construction to the -D, but the -CC and -CD differ radically from the conventional construction. Two sets of brass stator plates are interleaved and insulated from each other and from ground. The capacitance between these two stator stacks is varied by a set of grounded rotor plates, with 180° annular windows, interposed between the stators. The direct capacitance between stator stacks is directly proportional to the effective area exposed through the annular opening and, hence, to the angle of rotation of the rotor. This construction yields extremely low losses and a high degree of linearity.

### FEATURES:

- High stability.
- High precision of setting—one part in 25,000 of full scale; total scale length is 20 feet.
- High accuracy.
- Low backlash.
- Low temperature coefficient of capacitance.
- Low dielectric losses.
- Large transparent knob skirt to facilitate fine setting.

### SPECIFICATIONS

**Accuracy:** See table. The errors tabulated are possible errors, i.e., the sum of error contributions from setting, stability, adjustment, calibration, interpolation and standards. The probable errors are almost always smaller. The accuracy is increased when the readings are corrected using the 10 or more calibrated values of capacitance given on the correction chart on the capacitor panel and interpolating linearly between calibrated points. The highest accuracy can be obtained from a precision calibration of approximately 100 points on the capacitor dial, which permits correction for slight residual eccentricities of the worm drive and requires interpolation over only short intervals. This precision calibration is available for all models at an extra charge listed below. A mounted certificate of calibration is supplied, giving corrections to one more figure than the tabulated accuracy.

**Calibration:** The measured values are obtained by comparison, to a precision better than  $\pm(.01\% + .00001 \text{ pf})$ , with working standards whose absolute values are known to an accuracy typically  $\pm.02\%$ , determined and maintained in terms of reference standards periodically certified by the National Bureau of Standards.

The measured values of total capacitance of the two-terminal capacitors are the capacitances added when the TYPE 1422 Capacitor is plugged into a TYPE 874-Q9 Adaptor. The uncertainty of this method of connection is approximately  $\pm.03 \text{ pf}$ . Calibration of total capacitance with the fine-wire connection method\* used for the TYPE 722 Capacitors results in measured values approximately 0.45 pf lower than those obtained with the TYPE 874-Q9 Adaptor.

\*John F. Hersh, "A Close Look at Connection Errors in Capacitance Measurements," *General Radio Experimenter*, 33, 7, July, 1959.

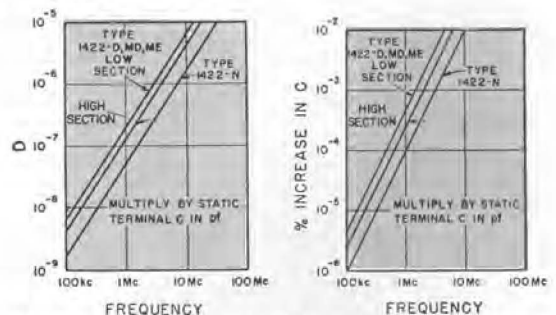

Variation with frequency of effective capacitance and D pf of capacitance for Type 1422 two-terminal Precision Capacitors.

**Resolution:** The dial can be read and set without difficulty to 1/5 division.

The backlash is less than one-fifth division, corresponding to .004% of full-scale value. If the desired setting is always approached in the direction of increasing scale reading, no error from this cause will result.

**Temperature Coefficient:** Approximately +.002% per degree Centigrade, for small temperature changes.

**Residual Parameters:** See table. The series resistance varies as the square root of the frequency above 100 kc. Its effect is negligible below this frequency.

**Frequency Characteristic:** See plots above, for two-terminal models. The resonance frequency for the -CB and -CC models is approximately 20 Mc; for the -CD model, 60 Mc for each section.

**Dissipation Factor:** The losses in the two-terminal ca-



# CAPACITORS

PRECISION AIR



TYPE 1422		TWO-TERMINAL							THREE-TERMINAL			
				RF	READS CAPACITANCE REMOVED							
		-D	-N	-MD	-ME	-CB	-CC	-CD				
CAPACITANCE RANGE, pf:	Min	100	35	100	0	0	0	0	50	5	0.5	.05
	Max	1150	115	1150	1050	105	105	10.5	1100	110	11	1.1
SCALE, pf/Division:		0.2	.02	0.2	0.2	.02	.02	.002	0.2	0.02	.002	.0002
ACCURACY: $\pm$ Picofarads listed below or $\pm$ .03%, whichever is greater												
Direct-Reading (Adjustment):												
Total Capacitance		0.6*	0.1*	0.6*	Differences from Zero				0.6	0.15	.04	.008
Capacitance Difference		1.2	0.2	1.2	1	0.2	0.2	.05	1.2	0.3	.08	.016
With Corrections from Calibration Chart (supplied):												
Total Capacitance		0.3*	.04*	0.3*					0.3	.04	.01	.002
Capacitance Difference†		0.6	.08	0.6	0.6	.08	.08	.02	0.6	.08	.02	.004
With Corrections from Precision Calibration (extra charge):												
Total Capacitance		0.1*	.01*	0.1*					0.1	.01	.001	.0002
Capacitance Difference†		0.2	.02	0.2	0.2	.02	.02	.004	0.2	.02	.002	.0004
STABILITY: Capacitance change per year not greater than 1 scale division												
RESIDUALS (typical values):												
Series Inductance, $\mu$ h		.06	0.10	.024	.06	0.10	.06	0.10	0.14	0.17	0.17	0.17
Series Resistance, ohms at 1Mc		.02	.03	.008	.02	.03	.02	.03	0.1			
Terminal Capacitances, pf:		high terminal to case						min scale	20	560	74	23
								max scale	20	850	98	25
		low terminal to case						min scale	33	600	92	93
								max scale	36	920	117	115
Capacitance at Zero Scale Setting, pf:					1140	135	145	35				

\*Total capacitance is the capacitance added when the capacitor is plugged into a TYPE 874-Q9 Adaptor.

†Divide error by 2 when one setting is made at a calibrated point.

capacitors are primarily in the stator supports, which are of low-loss polystyrene ( $DC = .01 \times 10^{-12}$ ).

The very small dissipation factor of the direct capacitance of the three-terminal capacitors is difficult to measure and is estimated to be not greater than  $20 \times 10^{-6}$  for -CB,  $10 \times 10^{-6}$  for -CC, -CD.

**Insulation Resistance:** Under standard conditions (23 C, less than 50% RH), greater than  $10^{12}$  ohms.

**Maximum Voltage:** All models, 1000 volts, peak.

**Terminals:** Jack-top binding posts are provided on 2-terminal models; standard  $\frac{3}{4}$ -inch spacing is used. The

rotor terminal is connected to the panel and shield. Locking Type 874 Coaxial Connectors are used on 3-terminal models.

**Accessories Supplied:** 2 TYPE 874-C58 Cable Connectors with all three-terminal models.

**Accessories Available:** TYPE 874-Q9 Adaptor.

**Mounting:** The capacitor is mounted on an aluminum panel finished in crackle and enclosed in a dust-tight  $\frac{1}{8}$ -inch-thick aluminum case.

**Dimensions:** Panel, 7 by  $9\frac{1}{2}$  inches; depth,  $8\frac{1}{8}$  inches, (180 by 240 by 205 mm) over-all.

TYPE		NET WEIGHT		CODE WORD	PRICE	ADDITIONAL PRICE FOR PRECISION CALIBRATION†
		POUNDS	KG			
1422-D	Precision Capacitor	11¼	5.1	RAPID	\$265.00	\$ 90.00
1422-MD	Precision Capacitor	11	5	RAVEL	265.00	90.00
1422-ME	Precision Capacitor	10½	4.8	RAZOR	255.00	110.00
1422-N	Precision Capacitor	10¾	4.9	READY	250.00	50.00
1422-CB	Precision Capacitor	10¾	4.9	REBUS	250.00	55.00
1422-CC	Precision Capacitor	12½	5.7	RECUR	280.00	55.00
1422-CD	Precision Capacitor	11	5	REDAN	280.00	165.00

†When ordering capacitor with precision calibration, add WORMY to capacitor code word.





## TYPE 1401 STANDARD AIR CAPACITOR (TWO-TERMINAL)

**USES:** The TYPE 1401 Standard Air Capacitors are accurate and stable two-terminal fixed air capacitors for laboratory use as reference or working standards. They supplement the TYPE 1409 series of fixed mica capacitors by providing standards of lower loss and lower capacitance.

**DESCRIPTION:** The aluminum plate assemblies are supported by a low-loss (96% quartz) mounting plate attached to an aluminum casting. This casting, together with the cylindrical aluminum case, provides a dust-free enclosure and a complete shield. The low, or ground, terminal of the capacitor is connected to this shield. Three supporting rods are used for each of the plate assemblies, ensuring a high degree of rigidity and stability, and all plates, rods, and spacers are aluminum, to minimize thermal stresses. Terminals are insulated by polystyrene bushings.

**FEATURES:**

- High accuracy and stability.
- Low temperature coefficient.
- Low losses.
- Convenient size.

**SPECIFICATIONS**

**Accuracy of Adjustment:** See table.

**Calibration:** A certificate of calibration is supplied with each unit giving the measured capacitance at 1 kc and at a specified temperature. The measured capacitance is the capacitance added when the standard is plugged

directly into General Radio binding posts. This value is obtained by comparison, to a precision better than  $\pm .01\%$ , with working standards whose absolute values are known to an accuracy typically  $\pm .02\%$ , determined and maintained in terms of reference standards periodically certified by the National Bureau of Standards.

**Stability:** Capacitance change is less than  $.05\%$  per year.

**Residual Impedances:** The series inductance of all units is approximately  $.05 \mu\text{h}$ . The variation in effective terminal capacitance caused by this inductance is shown in the accompanying plot.

The metallic resistance of all units is approximately  $.027 \text{ ohm}$  at one megacycle per second. The series resistance varies as the square root of frequency above about 100 kc.

**Temperature Coefficient of Capacitance:**  $+20 \pm 5 \text{ ppm}$  per degree C between 20 and 70 C.

**Dissipation Factor:** See table for typical values.

**Terminals:** TYPE 274 Plugs, spaced  $\frac{3}{4}$  inch on centers, to plug into TYPE 938 Binding Posts.

**Dimensions:** Diameter,  $3\frac{1}{16}$  inches (78 mm), height  $4\frac{1}{8}$  inches (124 mm), over-all.

**Net Weight:**  $1\frac{1}{8}$  lb (0.5 kg).

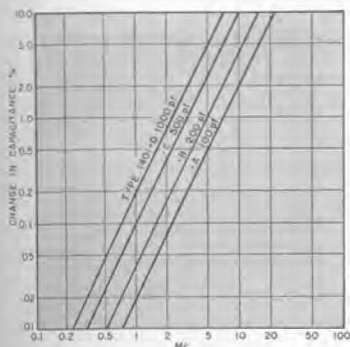

Change in effective terminal capacitance (percent) with frequency for the Type 1401 Standard Air Capacitors.

TYPE	INSERTION CAPACITANCE	ADJUSTMENT ACCURACY	MAX VOLTS	DISSIPATION FACTOR	CODE WORD	PRICE
1401-A	100 pf	0.2%	1500	$100 \times 10^{-6}$	HABIT	\$50.00
1401-B	200 pf	0.15%	1200	$50 \times 10^{-6}$	HONOR	51.00
1401-C	500 pf	0.12%	900	$20 \times 10^{-6}$	HOLLY	53.00
1401-D	1000 pf	0.1%	700	$10 \times 10^{-6}$	HANDY	58.00

## TYPE 1403 STANDARD AIR CAPACITOR (THREE-TERMINAL)

**USES:** For measurement at 100 pf and below, a three-terminal connection increases the accuracy by eliminating the uncertainty in the measurement introduced by the capacitances between the capacitor terminals and ground.

The TYPE 1403-A Standard Air Capacitors are stable, three-terminal standards overlapping the range of the TYPE 1401 and extending downward to  $.01 \text{ pf}$ .

# CAPACITORS

## STANDARD AIR



**Accuracy of Adjustment:** See table below.

**Calibration:** A certificate of calibration is supplied with each unit giving the measured capacitance at 1 kc and at a specified temperature. The measured value is the direct capacitance between shielded terminals when the capacitor has at least one lead completely shielded and its case connected to a guard point. This value is obtained by comparison, to a precision better than  $\pm(.01\% \pm .00001 \text{ pf})$ , with working standards whose absolute values are known to an accuracy typically  $\pm .03\%$ , de-

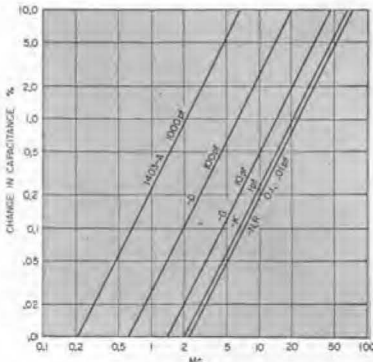

Change in effective direct capacitance with frequency produced by residuals.

TYPE	NOMINAL CAPACITANCE	ADJUSTMENT ACCURACY	MAX VOLTS	DISSIPATION FACTOR	CODE WORD	PRICE
1403-A	1000 pf	0.1%	700	$10 \times 10^{-6}$	DABBY	\$60.00
1403-D	100 pf	0.1%	1500	$10 \times 10^{-6}$	DAIRY	55.00
1403-G	10 pf	0.1%	1500	$10 \times 10^{-6}$	DASHY	48.00
1403-K	1.0 pf	0.1%	1500	$10 \times 10^{-6}$	DATUM	45.00
1403-N	0.1 pf	0.1%	1500	$10 \times 10^{-6}$	DAUNT	45.00
1403-R	.01 pf	0.3%	1500	$10 \times 10^{-6}$	DAVIT	45.00

## TYPE 1409 STANDARD CAPACITOR

**USES:** The TYPE 1409 Standard Capacitors are fixed mica capacitors of very high accuracy and stability for use as two- or three-terminal reference or working standards in the laboratory. For precise measurement and standardization of capacitance up to several microfarads, a set of these standards, used with the TYPE 716-C Capacitance Bridge, is recommended.

**DESCRIPTION:** The three largest sizes are similar in construction to the TYPE 1401, but have shielded terminals, both of which are insulated from the case. The smaller-capacitance units are made up of two plates, with a grounded plate between them; an aperture in the grounded plate determines the magnitude of the direct capacitance. Dielectric losses are not detectable; there is no solid dielectric in the direct-capacitance field.

### FEATURES:

- Provides standards down to .01 pf.
- Negligible dielectric loss.
- Low residual impedance.

### SPECIFICATIONS

Equivalent circuit of Type 1403 Standard Capacitor showing the calibrated direct capacitance,  $C_d$ , and the average values of the residual inductance,  $L$ , and the terminal capacitances,  $C_a$  and  $C_b$ .

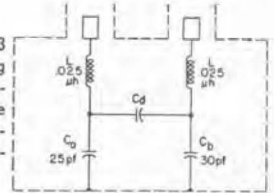

terminated and maintained in terms of reference standards periodically certified by the National Bureau of Standards.

**Stability:** Capacitance change is less than .05% per year.  
**Residual Impedances:** See equivalent circuit for typical values of internal series inductance and terminal capacitances. See curves for change in effective direct capacitance with frequency produced by the residual inductance.

**Temperature Coefficient of Direct Capacitance:**  $+30 \pm 10$  ppm per degree C between 20 and 70C.

**Dissipation Factor:** See table for typical values.

**Terminals:** TYPE 874 Coaxial Connectors, which provide complete shielding of the leads.

**Accessories Supplied:** Two TYPE 874-C58 Cable Connectors.

**Dimensions:** Diameter,  $3\frac{1}{16}$  inches (78 mm), height  $4\frac{7}{8}$  inches (124 mm), over-all.

**Net Weight:** One pound (0.46 kg).





# CAPACITORS

## STANDARD MICA

are shielded from external fields and from humidity by being mounted, with silica gel to provide continuous desiccation, in cast aluminum cases, sealed with high-temperature potting wax. A hole is provided in the wall of the case for the insertion of a dial-type bimetallic thermometer. Three jack-top binding posts are provided on the top of the case and three removable plugs on the bottom, for convenient parallel connection without error. The capacitor terminals are insulated from the third (ground) terminal, so that either a two- or three-terminal connection can be used.



### FEATURES:

- Stable within  $\pm .01\%$  per year.
- Calibrated for both two-terminal and three-terminal connections.

- Plug-in terminals permit several units to be stacked one upon the other without the use of leads and without cumulative error.

### SPECIFICATIONS

**Accuracy of Adjustment:** Within  $\pm .05\%$  of the nominal capacitance value (two-terminal) marked on the case.

**Calibration:** A certificate of calibration is supplied with each unit, giving both two- and three-terminal measured capacitances at 1 kc and at a specified temperature. The measured value is the capacitance added when the standard is plugged directly into General Radio binding posts. This value is obtained by comparison, to a precision better than  $\pm .01\%$ , with working standards whose absolute values are known to an accuracy typically  $\pm .02\%$ , determined and maintained in terms of reference standards periodically certified by the National Bureau of Standards.

**Stability:** Capacitance change is less than  $.01\%$  per year.

**Temperature Coefficient of Capacitance:**  $\pm 35 \pm 10$  ppm per degree Centigrade between 10 and 70 C.

**Dissipation Factor:** Less than .0003 at 1 kc and 23 C (see curves). Measured dissipation factor at 1000 cps is also given in the certificate.

**Frequency Characteristics:** See typical curves below. Values of series inductance and series resistance at 1 Mc are given in the table. This resistance varies as the

square root of the frequency for frequencies above 100 kc.

**Terminal Capacitance:** The capacitance from the H terminal to the case (G) is of the order of 12–50 pf.

The capacitance from the L terminal (outside foils of capacitor) to the case is of the order of 300–1300 pf.

**Leakage Resistance:** 5000 megohm-microfarads or 100,000 megohms, whichever is the lesser.

**Maximum Voltage:** 500 volts peak at frequencies below the limiting frequencies tabulated below. At high frequencies the allowable voltage decreases and is inversely proportional to the frequency, approximately. These limits correspond to a temperature rise of 40 degrees Centigrade for power dissipations of 5, 6, and 7.5 watts for the small, medium, and large cases, respectively.

**Mounting:** Cast aluminum cases with rubber feet.

**Terminals:** Two insulated jack-top terminals, plus jack-top terminal and ground strap.

**Dimensions:** Small case,  $3\frac{1}{4}$  by 4 by 2 inches (85 by 105 by 50 mm); medium case,  $3\frac{1}{4}$  by 4 by  $2\frac{1}{16}$  inches (85 by 105 by 70 mm); large case,  $3\frac{1}{4}$  by  $5\frac{5}{8}$  by  $2\frac{1}{16}$  inches (85 by 145 by 70 mm).

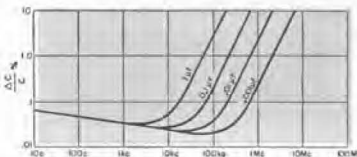

(Left) Change in capacitance as a function of frequency for typical Type 1409 Capacitors. The 1-kc value on the plot should be used as a basis of reference in estimating frequency errors.

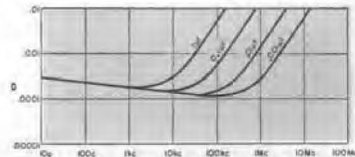

(Right) Dissipation factor as a function of frequency.

TYPE	NOMINAL CAPACITANCE $\mu\text{f}$	MAXIMUM PEAK VOLTS	FREQUENCY LIMIT FOR MAX VOLTS	SERIES INDUCTANCE $\mu\text{h}$	RESISTANCE IN OHMS AT 1 MC	WEIGHT	CODE WORD	PRICE
1409-F	.001	500	4.0 Mc	.050	.02	$1\frac{1}{4}$ lb (0.6 kg)	GOODCONBOY	\$ 32.00
1409-G	.002	500	2.3 Mc	.050	.02	$1\frac{1}{4}$ lb (0.6 kg)	GOODCONBUG	32.00
1409-K	.005	500	1.1 Mc	.050	.02	$1\frac{1}{4}$ lb (0.6 kg)	GOODCONCAT	34.00
1409-L	.01	500	640 kc	.050	.02	$1\frac{1}{4}$ lb (0.6 kg)	GOODCONDOG	34.00
1409-M	.02	500	370 kc	.050	.02	$1\frac{1}{4}$ lb (0.6 kg)	GOODCONEYE	36.00
1409-R	.05	500	175 kc	.055	.02	$1\frac{1}{4}$ lb (0.6 kg)	GOODCONPIG	39.00
1409-T	.1	500	100 kc	.055	.02	$1\frac{1}{4}$ lb (0.6 kg)	GOODCONROD	42.00
1409-U	.2	500	50 kc	.055	.02	$1\frac{1}{4}$ lb (0.6 kg)	GOODCONSIN	50.00
1409-X*	.5	500	20 kc	.055	.02	$1\frac{3}{4}$ lb (0.8 kg)	GOODCONSUM	90.00
1409-Y†	1.0	500	10 kc	.070	.03	$2\frac{1}{2}$ lb (1.1 kg)	GOODCONTOP	160.00

\*Mounted in medium case.

†Mounted in large case.



# CAPACITORS

## STANDARD



### TYPE 1424-A

### STANDARD POLYSTYRENE

### DECADE CAPACITOR

1  $\mu\text{f}$  to 10  $\mu\text{f}$



**USES:** This single-decade capacitor extends to 10  $\mu\text{f}$  the range of General Radio's accurate decade standards of capacitance. It provides ten individual standards, one at each integral microfarad value from 1 to 10. For maximum accuracy in bridge measurements, and standardization and for general laboratory use, residual series inductance and resistance have been kept to a minimum by careful design.

**DESCRIPTION:** Twenty polystyrene capacitors of 0.5  $\mu\text{f}$  each are assembled in pairs to give ten 1- $\mu\text{f}$  units. These are housed in two hermetically solder-sealed brass cases with Teflon-insulated high terminals, the cases being the common (LOW) terminal. The aluminum outer cabinet and panel are insulated from both the HIGH and LOW capacitor terminals, so that either two- or three-terminal connections can be used.

Residual series inductance and resistance have been minimized by the use of current-sheet conductors, ribbon leads, and multiple switch contacts.

Leakage resistance is very high, corresponding to a time constant of 12 days. Consequently, a discharge position is provided on the switch to minimize the danger of electrical shock to the operator. Charging current is also limited by the switching arrangement, to avoid damage to the capacitor.

#### FEATURES:

- High accuracy.
- Low series residuals.
- Low dissipation factor.
- High leakage resistance.
- Discharge switch position provided.

#### SPECIFICATIONS

**Nominal Value:** 0 to 10 microfarads, in steps of 1 microfarad.

**Adjustment Accuracy:**  $\pm 0.25\%$  at 1 kc.

**Certificate:** A certificate is supplied giving measured values, obtained by comparison, to a precision better than .01%, with working standards maintained to an accuracy of  $\pm .03\%$  in terms of NBS-certified reference standards.

**Stability:**  $\pm .05\%$  per year.

**Frequency:** Calibrated at 1 kc. Variation with frequency down to 60 cps is typically less than  $+ .02\%$ . At higher frequencies, terminal capacitance rises as resonant frequency is approached (see curves).

**Voltage Recovery:** Less than 0.1% (see page 167).

**Dissipation Factor:**  $< .0002$  at 1 kc. (See curves for variation with frequency.)

**Temperature Coefficient:** Approximately  $-140$  ppm per degree C.

**Insulation Resistance:** Approximately one million ohm-farads.

**Maximum Voltage:** 500 volts peak, up to 10 kc.

**Mounting:** Aluminum cabinet and panel, finished in gray.

**Terminals:** A separate ground terminal is provided, permitting 2- or 3-terminal use.

**Dimensions:** Width 8, height  $7\frac{3}{4}$ , depth  $9\frac{1}{2}$  inches (203 by 195 by 241 mm), over-all.

**Net Weight:**  $16\frac{1}{2}$  pounds (7.5 kg).

Typical curves for Type 1424-A Standard Polystyrene Decade Capacitors. (Left) Change in capacitance as a function of frequency for Type 1424-A Standard Decade Capacitors. These changes are referred to the values which the capacitors would have if there were neither interfacial polarization nor series inductance. The 1-kc value on the plot should be used as a basis of reference in estimating frequency errors. (Right) Dissipation factor as a function of frequency.

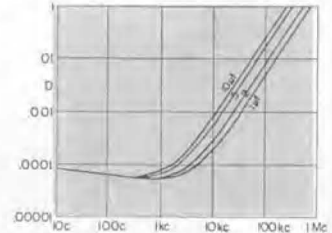
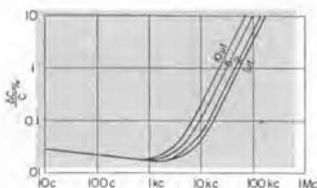

TYPE  
1424-A

Standard Polystyrene Decade Capacitor . . . . .

CODE WORD  
BAIRN

PRICE  
\$325.00





100 pf to 1.111  $\mu$ f

### TYPE 1423-A PRECISION DECADE CAPACITOR

**USES:** The TYPE 1423-A Precision Decade Capacitor provides 11,110 discrete values of capacitance each known to an accuracy of  $\pm 0.05\%$ . Any value of capacitance between 100 pf and 1.111  $\mu$ f, in steps of 100 pf, can be set on the four decades. Thus a bridge can be standardized quickly at any value within this range, to an accuracy that could be exceeded only by the use of individually certified laboratory standards of the highest available quality.

In conjunction with a limit bridge, such as the TYPE 1605-A Impedance Comparator, production-line measurements of arbitrary values of capacitance (such as EIA preferred values) can be made rapidly and accurately, with a minimum of setup time.

**DESCRIPTION:** This is a doubly shielded decade capacitor consisting of four decades of high-quality silvered-mica capacitors. The

two complete shields (Figure 1) make the capacitance at the terminals the same for either the two-terminal or the three-terminal method of connection, except for the external binding-post capacitance of about 1 pf added by the two-terminal connection. This external capacitance can be included in the calibration by the adjustment of a single trimmer.

Independent means for adjustment of capacitance are provided for each switch position on the two lowest decades and for each capacitor on the two highest decades. The terminal capacitance values are adjusted precisely to nominal value and can subsequently be readjusted at calibration intervals, if necessary, without disturbing the main capacitors.

The decades provide in-line readout for good visibility. The instrument is supplied with metal end frames for bench use; these may be removed for relay-rack mounting.

#### FEATURES:

- > Direct reading accuracy  $\pm 0.05\%$ .
- > Long-term stability  $\pm 0.01\%$  per year.
- > Easily readjusted in terms of certified reference standards.
- > Accurate for two-terminal and three-terminal use.

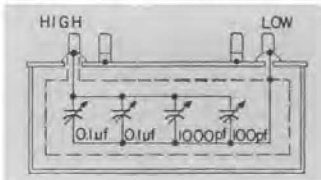

Figure 1

#### SPECIFICATIONS

**Nominal Values:** 100 pf to 1.111  $\mu$ f in steps of 100 pf.  
**Accuracy of Adjustment:**  $\pm 0.05\%$  at 1 kc, calibrated in the three-terminal connection using TYPE 874-Q9 Adaptors (supplied). Two-terminal connection (made by inserting the capacitor into TYPE 874-Q9 Adaptor) adds about 1.3 pf to reading.  
**Dissipation Factor**  
*D not greater than*

	<i>C range</i>
.001	100 pf to 1000 pf
.0005	1100 pf to 2000 pf
.0003	2100 pf to 1.1110 $\mu$ f

**Temperature Coefficient of Capacitance:** Approximately +35 ppm per degree Centigrade between 10 and 50 degrees C.

**Insulation Resistance:** Greater than 50,000 M $\Omega$  to 0.1  $\mu$ f and greater than 5,000 M $\Omega$  from 0.1  $\mu$ f to 1.111  $\mu$ f.  
**Calibration Frequency:** 1 kc.  
**Frequency Characteristic:** The behavior of each individual capacitor is similar to that of a TYPE 505 Capacitor (page 170).  
**Maximum Voltage:** 500 volts peak, up to 10 kc.  
**Accessories Supplied:** Two TYPE 874-Q9 Adaptors.  
**Mounting:** Aluminum relay-rack-style cabinet in gray, supplied with metal end frames for bench mounting.  
**Dimensions:** Width 19, height 7, depth 9 $\frac{3}{4}$  inches (483 by 178 by 248 mm), over-all.  
**Net Weight:** 26 pounds (11.8 kg).

TYPE	CODE WORD	PRICE
1423-A	Precision Decade Capacitor	LEVEL \$695.00

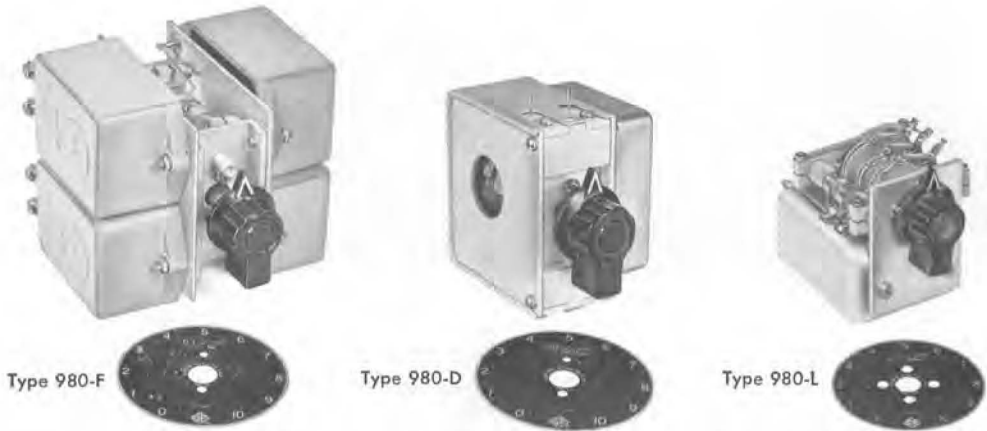

### TYPE 980 DECADE CAPACITOR UNIT

**USES:** The TYPE 980 Decade Capacitor Units are compact, convenient assemblies of high-grade capacitors mounted on an eleven-point switch to give a total capacitance variation of 10:1 in ten equal increments. They can be built into tuned circuits, wave filters, oscillators, analyzers, amplifiers, equalizers, and other permanent or experimental equipment.

Decades are available in three different dielectric materials: paper, for uses where dissipation factor is not critical; silvered mica for better dissipation factor and use in higher ambient temperatures; and polystyrene, for applications requiring very low dielectric absorption and constancy of both capacitance and dissipation factor as a function of frequency.

**DESCRIPTION:** Each decade consists of four capacitors of magnitudes in the ratio of 1, 2, 2, 5. The switch selects parallel combinations to give all integral values between 1 and 10.

The switch is rigidly constructed and includes a detent mechanism for positive loca-

tion of position. The switch dielectric, including the shaft, is heat-resistant, cross-linked polystyrene. Contacts are made by cams bearing on phosphor-bronze springs, the whole contact structure being heavily silver plated.

Units are furnished complete with knob, photo-etched dial plate, and switch stops. The switch, with dial plate and knobs, is available separately (see price list).

**FEATURES:**

- All component capacitors are carefully selected and aged, for maximum stability with time.
- Paper dielectric units are highly stable, sealed, firecracker-shaped, foil-and-paper capacitors having a viscous impregnant.
- Mica-dielectric decades use silvered-mica molded elements for TYPES 980-M and -N and TYPE 505 units for the TYPES 980-F, G, H, and J.
- Polystyrene decades have high insulation resistance, low dielectric absorption and low losses.

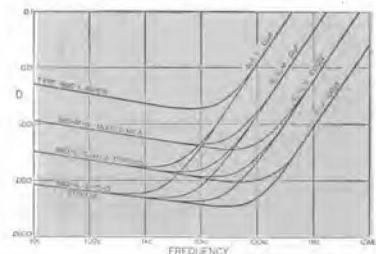
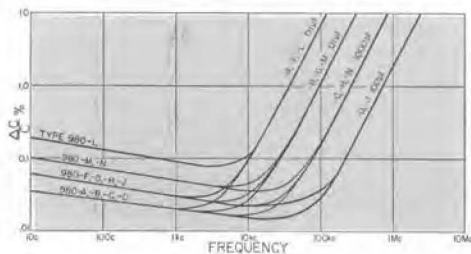

(Left) Typical plot of change in capacitance at maximum setting of each decade as a function of frequency. The capacitance curves are referred to the value the capacitor would have if there were no interfacial polarization and no series inductance. Since the capacitors are adjusted to their rated accuracy at 1 kc, the 1-kc value on the plots should be used as a basis of reference in estimating the frequency error. (Right) Typical plot of dissipation factor as a function of frequency.



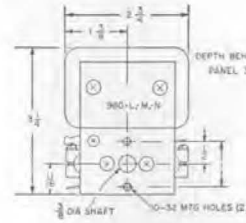
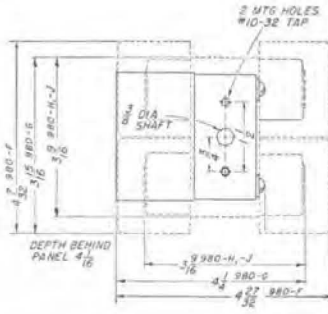
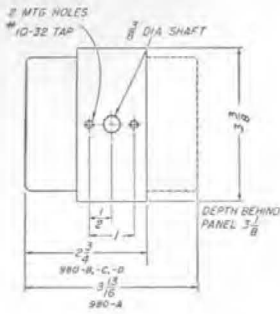

Panel space and mounting dimensions of Type 980 Decade Capacitor Units.

### SPECIFICATIONS

DIELECTRIC TYPE	POLYSTYRENE				SILVERED MICA — GR TYPE 505				PAPER	SILVERED MICA (MOLDED)		
	980-A	980-B	980-C	980-D	980-F	980-G	980-H	980-J	980-L	980-M	980-N	
Maximum Capacitance (μf)	1.0	0.1	.01	.001	1.0	0.1	.01	.001	1.0	0.1	.01	
Capacitance per Step (μf)	0.1	.01	.001	.0001	0.1	.01	.001	.0001	0.1	.01	.001	
Zero Capacitance	Approximately 11 pf											
	5 pf											
Accuracy	±1%		±1% + 2 pf		±0.5%			±(0.5% + 2 μf)		±1.5%	±1%	
	±1%	±1%	±1.5%	+1% - (2% + 4 pf)	±0.5%	±0.5%	±1%	+0, - (2% + 8 μf)	±1.5%	±1%	±1%	
Dissipation Factor	<.0002				<.0003				<.0006	<.005	<.001	
Insulation Resistance at 100 v, 25 C, 50% RH (ohms)	10 <sup>12</sup>				5 × 10 <sup>11</sup>	25 × 10 <sup>11</sup>	25 × 10 <sup>9</sup>	25 × 10 <sup>9</sup>	10 <sup>10</sup>	10 <sup>9</sup>	10 <sup>9</sup>	
Temperature Coefficient of Capacitance ppm/°C	-140 nominal				+35±10				+180	EIA Characteristic C		
Maximum Operating Voltage <sup>3</sup> (DC or peak)	500				500				500	500		
Frequency Limit for Maximum Voltage <sup>3</sup>	10 kc	100 kc	1 Mc	10 Mc	10 kc	100 kc	1 Mc	10 Mc	2 kc	100 kc	1 Mc	
Frequency Characteristic	See Curves											
Maximum Operating Temperature (C)	65				90				90	90		
Dielectric Absorption	See Voltage Recovery											
Voltage Recovery <sup>1</sup>	<0.1%				<3%				—			
Terminals	Flexible leads											
Mounting Hardware	Machine screws are furnished											
Dimensions	See sketch; to convert inches to mm, multiply by 25.4											
Net Weight	2 1/8 lb (1 kg)				3 3/4 lb (1.7 kg)	2 lb (0.9 kg)	1 1/8 lb (0.8 kg)	1 1/2 lb (0.7 kg)	1 3/8 lb (0.8 kg)	1 1/2 lb (0.7 kg)	1 1/2 lb (0.7 kg)	
Code Word	AVAST	AVERT	AVOID	ALIEN	ACUTE	AVOWD	AWAIT	ADIEU	ADAGE	ADDER	ADDLE	
Price	\$66.00	\$51.00	\$57.00	\$57.00	\$165.00	\$65.00	\$50.00	\$48.00	\$40.00	\$44.00	\$34.00	

Switch only, Type 980-P1, Code Word SWITCHBIRD, \$12.00

<sup>1</sup>Capacitance increments from zero position are within this percentage of the indicated value for any setting.

<sup>2</sup>Units are checked with switch mechanism high, electrically, and the common lead and case grounded.

<sup>3</sup>At frequencies above the indicated maximum, the allowable voltage decreases and is (approximately) inversely proportional to frequency. These limits correspond to a temperature of 40 C for a power dissipation of 2.5 watts for Type 980-F, one watt for Types 980-C, -H and -J, and 3.5 watts for all other units.

<sup>4</sup>Final % of original charging voltage after a charging period of one hour and a 10-second discharge through a resistance equal to one ohm per volt of charging.





Type 1419-A



Type 1419-K

## TYPE 1419 DECADE CAPACITORS

General Radio TYPE 1419 Decade Capacitors are assemblies of three or four TYPE 980 Decade Capacitors in shielded cabinets. All models have a multiplicity of uses in the electronics laboratory, as circuit elements in resonant circuits, bridges, filters, and experimental equipment. Each model has also its own specialized applications, by virtue of its design and construction features. Each model is described below, with complete specifications.

### TYPES 1419-A AND -B POLYSTYRENE DECADE CAPACITORS

**USES:** Owing to their very low dielectric absorption, the TYPES 1419-A and -B Polystyrene Decade Capacitors are particularly useful in research and development work on computer and integrator circuits and on low-level amplifiers. Their constancy of capacitance and dissipation factor as a function of frequency also makes them extremely useful in measurement circuits and as components in filters and tuned circuits. High insulation resistance and low dielectric absorption make them nearly ideal capacitors for dc work.

**DESCRIPTION:** These decade capacitors are based on development work and manufacturing experience at General Radio since 1940. The TYPE 1419-A consists of three individual Decade Capacitor Units, TYPES 980-A, -B, and -C. The TYPE 1419-B, a four-decade assembly, includes the above three units plus an additional TYPE 980-D, for better resolution. All TYPE 980 Units are designed to be essentially non-inductive and are heat-stabilized, so that their long-time stability approaches that of the best silvered-mica capacitors.

The capacitors are wound in spool form

from continuous interleaved tapes of polystyrene and metal foil. The foils, projecting at each end of the roll, are soldered together to minimize inductance and series resistance.

The tape used for the dielectric is specially prepared of purified high-molecular-weight polystyrene, having very high resistance and freedom from polarization. Hermetic sealing with teflon feed-through insulators assures high performance even under adverse humidity conditions.

Terminals are provided on the -A and -B models for both two-terminal and three-terminal connections.

### FEATURES:

- High insulation resistance.
- Low dielectric absorption.
- Low dielectric loss.
- Capacitance and dissipation factor vary only slightly with frequency from dc through the audio-frequency range.
- Completely shielded and hermetically sealed.
- All insulation of highest available quality.
- Three-terminal construction.

### TYPE 1419-K DECADE CAPACITOR

**USES:** This high-quality decade capacitor finds uses in every laboratory: in tuned circuits, impedance bridges, filters, or in any circuit where an accurate and stable variable capacitor is necessary.

Mica dielectric is used throughout, permitting operation at higher temperatures than is possible with polystyrene types.

**DESCRIPTION:** The TYPE 1419-K Decade Capacitor is an assembly of TYPE 980-F, -G, and



-H Decade Capacitor Units mounted in a shielded cabinet. The individual capacitors are General Radio TYPE 505 units, which are assembled from selected sheets of silvered mica.

### FEATURES:

- High stability.
- 0.5% accuracy.
- Low temperature coefficient.
- Three-terminal construction.
- Low dissipation factor.
- Shielded case.

### TYPE 1419-M DECADE CAPACITOR

**USES:** This new and improved "economy" decade capacitor offers excellent performance at moderate cost for those applications where dissipation factor is not a critical requirement. Terminals are provided for both two-terminal and three-terminal connections.

**DESCRIPTION:** The two lower capacitance decades, TYPES 980-M, and -N, use molded silvered-mica units, EIA characteristic C. The highest capacitance decade, TYPE 980-L (0.1  $\mu\text{f}$  per step), uses firecracker-shaped foil-and-paper capacitors having a viscous impregnant, with a resulting high degree of capacitance stability.

### SPECIFICATIONS

TYPE NUMBER	1419-A			1419-B		1419-K			1419-M		
	A	B	C	D	F	G	H	L	M	N	
Type 980 Decades Used											
Capacitance per Step ( $\mu\text{f}$ )	.01	.01	.001	.0001	0.1	.01	.001	0.1	.01	.001	
Dielectric	Polystyrene				Mica			Paper	Mica	Mica	
Maximum Capacitance of Box ( $\mu\text{f}$ )	1.110			1.1110	1.110			1.110			
Zero Capacitance (pf)	37			50	41			35			
	15			20	13			16			
Accuracy	2-terminal	$\pm 1\%$	$\pm 1\%$	$\pm 1\%$	$\pm (1\% + 2 \text{ pf})$	$\pm 0.5\%$	$\pm 0.5\%$	$\pm 0.5\%$	$\pm 1.5\%$	$\pm 1\%$	$\pm 1\%$
	3-terminal	$\pm 1\%$	$\pm 1\%$	$\pm 1.5\%$	$\pm 1\%$ to $-(2\% + 4 \text{ pf})$	$\pm 0.5\%$	$\pm 0.5\%$	$\pm 1\%$	$\pm 1.5\%$	$\pm 1\%$	$\pm 1\%$
Dissipation Factor at 1 kc	<.0002				<.0003			<.005	<.001	<.001	
Insulation Resistance in ohms at 100 v, 23 C, 50% RH	$10^{12}$				$3.5 \times 10^9$			$10^9$			
Temperature Coefficient of Capacitance (ppm/ $^{\circ}\text{C}$ )	-140, nominal				+35 $\pm$ 10						
Maximum Operating Temperature (C)	65				90			90			
Maximum Operating Voltage (DC or peak)	500				500			500	500	500	
Frequency Characteristic	Similar to those for the Type 980 Decade Capacitance Units, modified by the additional inductance and resistance at the box terminals and wiring.										
Dc Cap / 1-kc Cap	<1.001				Typically 1.03						
Dielectric Absorption					See Voltage Recovery						
Voltage Recovery <sup>2</sup>	<0.1%				<3%						
Terminals	Three Type 938 Binding Posts with grounding link				Three Type 938 Binding Posts with grounding link			Three Type 938 Binding Posts with grounded link			
Mounting	Aluminum Panel and Cabinet				Aluminum Panel and Cabinet			Aluminum Panel and Cabinet			
Over-all Dimensions	13 by 4 $\frac{3}{8}$ by 5 inches (330 by 109 by 127 mm)				14 $\frac{1}{8}$ by 5 $\frac{1}{2}$ by 6 inches (359 by 140 by 153 mm)			14 $\frac{1}{8}$ by 5 $\frac{1}{2}$ by 6 inches (359 by 140 by 153 mm)			
	16 $\frac{3}{8}$ by 4 $\frac{3}{8}$ by 5 inches (795 by 109 by 127 mm)										
Net Weight	8 $\frac{3}{8}$ lb (3.8 kg)				10 $\frac{1}{2}$ lb (4.8 kg)			11 $\frac{1}{4}$ lb (5.1 kg)			6 $\frac{1}{4}$ lb (2.9 kg)
	BIGOT				BEFIT			CREEK			BRIER
Code Word											
Price	\$205.00				\$262.00			\$315.00			\$145.00

<sup>1</sup>Capacitance increments from zero position are within this percentage of the indicated value for any setting.

<sup>2</sup>Final % of original charging voltage after a charging period of one hour and a 10-second discharge through a resistance equal to one ohm per volt of charging.





### TYPE 505 CAPACITOR

**USES:** The TYPE 505 Capacitors are stable, low-loss mica capacitors for use as high-quality circuit elements and as secondary standards where the higher accuracy, complete shielding, lower loss, and convenient connections of the TYPE 1409 Capacitors are not required.

**DESCRIPTION:** The TYPE 505 unit uses the same silvered-mica and foil pile used in the TYPE 1409 and has almost equally high

stability. The unit is sealed with wax in a low-loss phenolic case with silica gel to provide continuous desiccation and granulated polyethylene to absorb shock.

**FEATURES:**

- Small, convenient, stable, and accurate.
- Low-loss phenolic case to reduce dielectric loss and leakage conductance.
- Low temperature coefficient of capacitance.

### SPECIFICATIONS

**Accuracy:**  $\pm 0.5\%$  or  $\pm 3$  pf, whichever is the larger.  
**Temperature Coefficient:** Approximately  $+35$  ppm per degree Centigrade between 10 and 50 C. Calibration is made at 23 C, at a frequency of 1 kc.  
**Dissipation Factor:** .0003 for 1000 pf and higher; 500 pf, .00035; 200 pf, .0004; 100 pf, .0006.  
**Frequency Characteristics:** Similar to those for TYPE 1409 Standard Capacitors shown on page 163. Series inductance is approximately  $.055 \mu\text{h}$  for units in small case and  $.085 \mu\text{h}$  for large case. Series resistance at 1 Mc is approximately .03 ohm for small case and .05 ohm for large case, varying as square root of frequency above 100kc.  
**Leakage Resistance:** Greater than 100,000 megohms, when measured at 500 volts, except for the TYPES 505-T, 505-U, and 505-X, for which it is greater than 50,000, 25,000, and 10,000 megohms, respectively.  
**Maximum Voltage:** See table. At higher frequencies the allowable voltage decreases and is inversely proportional to the square root of the frequency. These limits

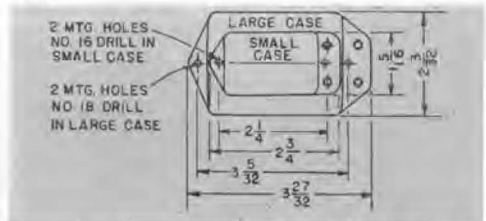

correspond to a temperature rise of 40 degrees Centigrade for a power dissipation of 1 watt for the small case and 2.5 watts for the large case.  
**Terminals:** Two screw terminals spaced  $\frac{3}{4}$  inch apart, with two removable plug bottoms, TYPE 274-P. High terminal (inside foil) is marked H.  
**Mounting:** Mica-filled, low-loss phenolic cases.  
**Dimensions:** See sketch; dimensions shown are in inches. Over-all height,  $1\frac{5}{8}$  inches for large case, 1 inch for small case, exclusive of plugs.

TYPE	CAPACITANCE	MAXIMUM PEAK VOLTS	FREQUENCY LIMIT FOR MAX VOLTS	WEIGHT IN OUNCES	CODE WORD	PRICE
505-A	100 pf	700	2000 kc	4	CONDENALLY	\$10.00
505-B	200 pf	700	1000	4	CONDENBELL	7.50
505-E	500 pf	500	1000	4	CONDENCOAT	7.50
505-F	.001 $\mu\text{f}$	500	800	4	CONDENDRAM	7.50
505-G	.002 $\mu\text{f}$	500	400	5	CONDENEYRE	7.50
505-K	.005 $\mu\text{f}$	500	160	5	CONDENFACT	7.50
505-L	.01 $\mu\text{f}$	500	80	5	CONDENGIRL	9.00
505-M	.02 $\mu\text{f}$	500	40	6	CONDENHEAD	11.50
*505-R	.05 $\mu\text{f}$	500	40	11	CONDENCALM	13.50
*505-T	.1 $\mu\text{f}$	500	20	12	CONDENCROW	20.00
*505-U	.2 $\mu\text{f}$	500	10	13	CONDENWIPE	30.00
*505-X	.5 $\mu\text{f}$	500	4	15	CONDENWILT	65.00

\*Mounted in large case.

## TYPE 1429-A FUEL-GAGE TESTER



**USES:** The TYPE 1429-A Fuel-Gage Tester meets the need for an accurate device for calibrating modern capacitance-type fuel-gage systems. It meets the requirements for testing and calibrating the gages in both reciprocating-engine and jet-engine planes.

**DESCRIPTION:** This tester fulfills the same function as the military TYPE MD-1 Tester, but has smaller dimensions and lower weight.

## SPECIFICATIONS

**Capacitance Range:** Main capacitor continuously variable linearly from 20 to 220 pf, thence by switched steps of 200 pf to 6220 pf. Compensating capacitor continuously variable linearly from 10 to 210 pf.

**Accuracy:** Capacitance of the main variable air capacitor is indicated by dial reading within  $\pm 0.5\%$  or  $\pm 0.75$  pf, whichever is greater. Corresponding figures for the compensating variable air capacitor are  $\pm 1.5\%$  or  $\pm 0.5$  pf, whichever is greater. Switched capacitors are accurate to  $\pm 0.5\%$ .

**Correction Chart:** A correction chart, laminated between plastic sheets for mechanical and climatic protection, is supplied, giving corrections at multiples of 10 pf for the variable capacitors and at each switch position for the stepped capacitors. When these corrections are applied, the capacitance is correct to plus or minus 0.1% or 0.15 pf, whichever is greater.

**Maximum Voltage:** 500 volts peak.

**Dielectric Supports:** Plates of low-loss steatite support the stator assembly, glass-bonded-mica washers the rotor.

**Dielectric Losses:** Almost negligible for the air capacitors,

It contains two 3-terminal, 200-pf- $\Delta$ C air capacitors, one to simulate the jet fuel compensator, the other in conjunction with fixed mica capacitors to simulate the main sensing capacitor of the fuel gage. Both air capacitors have brass rotor and stator plates soldered into their supports, then nickel-plated and mounted in a rigid, five-sided, cast-aluminum frame. The capacitor worm drive is individually ground in to fit the one-piece, spring-pressed worm and shaft to the precision worm wheel.

The main capacitor is extended in value to 6200 pf by two sets of switched, solder-sealed, precision, silvered-mica, fixed capacitors, one having five steps of 200 pf, the other five steps of 1000 pf.

External connections are made through keyed coaxial connectors. Cables and adaptors as required by specification MIL T-8579 (USAF) are stowed in a separate compartment at the right end of the transit case.

## FEATURES:

- Protected from moisture and vibration.
- High precision of setting—one part in 25,000 of full scale; scale length is 19.2 feet.
- High accuracy.
- Low backlash.
- Low temperature coefficient of capacitance.
- Low dielectric losses.
- Direct reading in capacitance.
- Fulfills functions and environmental requirements of military MD-1 Tester.

since solid insulation is largely outside the electric field. Not over .001 for the switched silvered-mica capacitors.

**Temperature Coefficient of Capacitance:** For small temperature changes, approximately  $+ .002\%$  per degree Centigrade for air capacitors,  $+ .0035\%$  for mica ones.

**Backlash:** Less than one-third division (out of 2000), corresponding to .02% of full-scale value. If the desired setting is always approached in the direction of increasing scale reading, no error from this cause will result.

**Terminals:** Three special, keyed, coaxial connectors, the center one of which is connected to both rotors.

**Mounting:** All capacitors and a renewable desiccant cartridge are mounted on an aluminum panel and enclosed in a moisture-sealed aluminum cabinet. The latter is shock-mounted in an aluminum transit case with carrying handle, which also contains a compartment to hold nine connecting cables and three tee adaptors.

**Dimensions:** Width  $17\frac{1}{2}$ , height  $10\frac{1}{2}$ , depth  $10\frac{1}{2}$  inches (445 by 270 by 270 mm), over-all.

**Weight:**  $28\frac{3}{4}$  pounds (13 kg).

TYPE		CODE WORD	PRICE
1429-A	Fuel-Gage Tester .....	GAGER	\$900.00

# STANDARD INDUCTORS



When an inductor is to be used as a standard, its inductance value should have the smallest possible changes with time, frequency, current, temperature, external fields, or environment. The residual impedances, series resistance, and effective shunt capacitance should be as low as possible. The best accuracy is achieved when the connections to the inductor can be made without the introduction of uncertainties into the calibrated value. The extent to which an inductor can incorporate these attributes can best be understood by consideration of the design factors described below.

## Construction:

To minimize the generation of, or pickup from, external magnetic fields, the toroidal form of inductor is to be preferred to the solenoidal form. The symmetry of the toroid contributes both to stability and to a constant temperature coefficient. The capacitance, in a multilayer winding, can be kept at a minimum when the layers are continually being built up, while the winding progresses only once around the circumference of the toroid, so that the potential difference between adjacent turns is small.

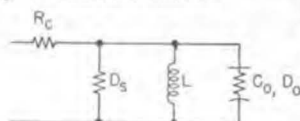

Figure 1. Equivalent circuit of an air-cored inductor,  $L$ .

An air core in the inductor results in the highest stability and a negligible variation of inductance with current, but at the expense of a relatively low  $Q$ . Because stability is the prime requirement in a laboratory standard, the TYPE 1482 Standard Inductors are air-cored.

For a given core volume or amount of copper, a larger inductance and  $Q$  can be obtained from a core of the high-permeability ferromagnetic materials, often loosely and generically termed "iron," although they are highly developed special alloys in sheet, strip, or bonded-granular form. Since the permeability of the material is subject to change with age and particularly with current, the iron-cored inductor is inherently less stable than the air-cored type. Good stability can still be realized in iron-cored inductors, along with the high  $Q$  and small size, by proper design and choice of core materials, as in the TYPE 1481 Inductors.

## Inductance Changes:

The inductance of an inductor depends not only upon the geometry and the permeability of the core but upon the residual impedances. The principal residual resistances and capacitances are shown in the equivalent circuit of Figure 1. The largest changes of inductance with frequency are produced by the capacitance  $C_o$  of the winding and the terminals. As the frequency,  $f$ , increases, the effective inductance becomes greater than the zero-frequency inductance  $L_o$  by an amount  $\Delta L$ . When  $f$  is well below the resonance frequency,  $f_o$ , the fractional increase is approximately —

$$\frac{\Delta L}{L_o} = \omega^2 L_o C_o = \left(\frac{f}{f_o}\right)^2$$

On the following pages this variation of inductance with frequency is given for the inductors in the form of plots on logarithmic co-ordinates of  $\Delta L/L_o$  in percent vs frequency in kilocycles. There is also a decrease in  $L$  with increasing frequency, produced by eddy currents in the winding and in ferromagnetic cores; this change can be kept relatively small by the use of stranded wire

(Litzendraht) and of powdered core materials.

There is practically no change in inductance with current when the core is air, but cores of ferromagnetic materials have a permeability that changes with magnetizing force, and therefore they usually show an appreciable change of inductance with current. The change of inductance with current shown on page 177 for the TYPE 1481 and 940 Inductors is typical in that the increase is linear over a small region near zero current, then increases more rapidly to a maximum followed by a sudden decrease as the material approaches saturation. To make such a curve independent of the inductance magnitude, it is convenient to normalize the current to a value  $I_1$  which is approximately the upper limit of the linear range and to plot  $I/I_1$ . The magnitude of  $I_1$  varies with the inductance and with the core material. For the molybdenum-permalloy dust cores used in the TYPE 1481 Inductors,  $I_1$  has been chosen to be that current which produces an increase,  $\Delta L/L_o$ , of 0.25% when the core has a permeability of 125 and an increase of 0.1% when the permeability is 26.

## Q Changes:

The  $Q$  of an inductor, i.e.,  $\omega L/R$ , is simply proportional to frequency when  $L$  and  $R$  are constant. But, as noted above,  $L$  can vary with frequency, and the losses are also functions of frequency. In an air-cored inductor, the losses, as shown in Figure 1, are an "ohmic" loss from the series resistance ( $R_c$ ) of the winding, a loss ( $D_s$ ) caused by eddy currents in the copper, and dielectric losses ( $D_o$ ) in the insulation. These loss components are best described in terms of dissipation factor,  $D = 1/Q$ , since the total  $D$  is the sum of the component  $D$ 's and these can be plotted as straight lines in logarithmic co-ordinates, as shown in Figure 2. The component  $D_c$ , from the dc resistance of the winding, varies inversely with frequency, while the component  $D_s$ , from eddy-current or skin-effect loss in the copper, is directly proportional to frequency. The third component  $D_o$ , from the loss in the winding capacitance, is proportional to the square of frequency in the range where the dissipation factor  $D_o$  of that capacitance is independent of frequency. At the resonance frequency,  $f_o$ , the value of  $D_o$  is  $D_c$ . The total dissipation factor  $D$  (Figure 2) is the sum of these components and has a minimum value at a frequency usually below the resonance frequency  $f_o$ . At low frequencies the  $D$  or  $Q$  is determined by the series resistance; at high frequencies the eddy-current and dielectric losses predominate.

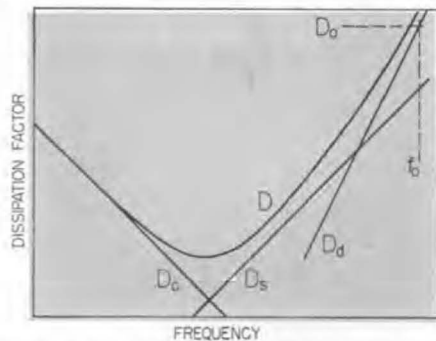

Figure 2. Dissipation factor variation with frequency showing the relative contributions of the several loss components for air-cored inductors.



In an iron-cored inductor the higher permeability makes possible lower values of  $D_e$  and  $D_r$ , while  $f_o$  is slightly reduced and  $D_o$  is not changed. The core adds three more components to the winding losses shown in Figure 2. Eddy currents in the core produce a component  $D_e$  which usually exceeds  $D_r$  and which, like  $D_r$ , is proportional to frequency. The component  $D_h$ , from hysteresis loss in the core, is independent of frequency, and since it is proportional to magnetizing force, it becomes negligible when the current approaches zero. A third component  $D_v$ , from residual losses in the core, is also constant with frequency and is usually relatively small.

The effects of these losses are shown on the following pages by plots of  $Q$  versus frequency for the various inductors.

#### Calibration:

The calibrated inductance of a standard inductor is the change in the measured inductance of a circuit when a portion of that circuit is removed and replaced by the inductor. This measured inductance includes small and variable mutual inductances between the inductor and the rest of the circuit, which are negligible when the calibrated inductance is larger than, say, 100 microhenrys, but which can introduce accuracy-limiting uncertainties into the calibration of smaller inductance. These uncertainties can be reduced to less than .001 microhenry to permit accurate calibrations down to 1 microhenry, if the mutual components are made a definite part of the calibrated inductance. One method of achieving this, used in the TYPE 1482 Standard Inductors of 200 microhenrys and less, is to provide, on

the inductor, a switching link which connects either the inductor coil or a short circuit through internal leads to the external connection terminals. The calibrated inductance, which is the measured difference at the connection terminals when the switch is moved from coil to short, is to a high degree independent of the external connections or environment.\* Since the inductance of most inductors varies with frequency, an accurate calibration requires that the frequency be specified. When, as in inductors with iron cores, the inductance also varies with current, the calibration must also specify a corresponding current or voltage. Since the frequency or current at which the inductor will be used is not usually known, a convenient reference level is zero frequency and zero current (initial permeability). For example, the TYPE 1481 Inductors are measured at a frequency considerably lower than their resonance frequency, and the measured value is corrected for the increase of  $L$  with frequency to obtain the value as frequency approaches zero: they are measured at two currents within the linear range (less than  $I_1$ ), and the measured values are extrapolated to obtain the inductance at zero current and at the initial permeability of the core material.

The inductors described in this section are intended for use in standards and measurement laboratories. They include highly stable air-cored reference standards, fixed-value units with ferromagnetic cores, continuously variable (variometer) types, and decade assemblies.

\*John F. Hersh, "Connection Errors in Inductance Measurement" *General Radio Experimenter*, Vol. 34, No. 10, October, 1960.

TYPE	NAME	INDUCTANCE	PAGE
1482	Standard Inductor	50 $\mu$ h to 10 h in 17 models	173
107	Variable Inductor	9 $\mu$ h to 500 mh in 5 models	175
1481	Inductor	1 mh to 5 h in 15 models	176
940	Decade-Inductor Unit	5 models, .0001-, .001-, .01-, 0.1-, and 1-h steps	177
1490	Decade Inductor	3-dial and 4-dial boxes	178

## TYPE 1482 STANDARD INDUCTOR



**USES:** The TYPE 1482 Standard Inductor is an accurate and highly stable standard of self-inductance for use as low-frequency reference or working standards in the laboratory. Records extending over 9 years and including inductors which travelled to national laboratories in several countries for calibration show long-term stabilities well within  $\pm .01\%$ .

**DESCRIPTION:** Each inductor is a uniformly wound toroid on a ceramic core. It has a negligible external magnetic field and essentially no pickup from external fields. The inductor is resiliently supported in a mixture of ground cork and silica gel, after which the whole assembly is cast with a potting compound into a cubical aluminum case.

Sizes of 500  $\mu$ h and above have three terminals, two for the inductor leads and the third

# INDUCTORS

## STANDARD



connected to the case, to provide either a two- or three-terminal standard. The 50-, 100-, and 200- $\mu$ h sizes have three additional terminals for the switching used to minimize connection errors, as described on page 173.

For comparing other inductors with these standards, the TYPE 1632-A Inductance Bridge is recommended.

### FEATURES:

- Stable within  $\pm .01\%$  per year.
- Precisely adjusted and accurately calibrated.
- Inductance independent of voltage.
- Connection errors minimized.
- Low external field.
- Low and known temperature coefficient.
- Free from humidity errors.



## SPECIFICATIONS

**Inductance Range:** See table.

**Temperature Coefficient of Inductance:** Approximately 30 ppm per degree C. Minute temperature corrections may be computed from dc resistance changes. A 1% increase in resistance, produced by a temperature increase of 2.54 C, corresponds to .0076% increase in inductance.

**Accuracy:** See table for adjustment accuracy. A certificate of calibration is provided with each unit, giving measured values of inductance at 100, 200, 400, and 1000 cps, with temperature and with method of measurement specified. The measured values are obtained by comparison, to a precision of better than  $\pm .005\%$ , with working standards whose absolute values, determined and maintained in terms of reference standards periodically certified by the National Bureau of Standards, are known to an accuracy typically  $\pm (.02\% + 0.1\mu\text{h})$  at 100 cps.

**Stability:** Inductance change is less than  $\pm .01\%$  per year.

**DC Resistance:** See table for representative values. A

measured value of resistance at a specified temperature is given on the certificate of calibration.

**Low-Frequency Storage Factor Q:** See table for representative values of Q at 100 cps (essentially from dc resistance). A value of Q, calculated from the measured dc resistance, is given on the certificate of calibration.

**Resonant Frequency:** See table for representative values. A measured value is given on the certificate of calibration.

**Maximum Input Power:** For 20 C rise, 3 watts.

For precise work, 1.5 C rise, 200 milliwatts. See table for corresponding current limits.

**Mounting:** Aluminum cabinet with carrying handle and rubber feet. Finished in gray.

**Terminals:** Jack-top binding posts on  $\frac{3}{4}$ -inch spacing with removable ground strap.

**Dimensions:** 6 $\frac{1}{2}$  by 6 $\frac{1}{2}$  by 8 inches (165 by 165 by 205 mm), over-all.

**Net Weight:** 11 $\frac{1}{2}$  pounds (5.5 kg).

TYPE	NOMINAL INDUCTANCE	ADJUSTMENT ACCURACY PERCENT	*RESONANT FREQUENCY KC	*DC RESISTANCE OHMS	*Q AT 100 CPS	MILLIAMPERES		CODE WORD	PRICE
						RMS FOR 200 MW	3 W		
1482-A	50 $\mu$ h	$\pm 0.5$	3400	.043	0.73	2160	8350	INDUCTOGAP	\$125.00
1482-B	100 $\mu$ h	$\pm 0.25$	2500	.090	0.70	1430	5530	INDUCTOTAG	125.00
1482-C	200 $\mu$ h	$\pm 0.25$	1440	0.170	0.74	1010	4200	INDUCTOTED	125.00
1482-D	500 $\mu$ h	$\pm 0.1$	1020	0.385	0.82	720	2790	INDUCTOTIM	110.00
1482-E	1 mh	$\pm 0.1$	770	0.860	0.73	480	1870	INDUCTOTOP	110.00
1482-F	2 mh	$\pm 0.1$	570	1.56	0.80	360	1390	INDUCTOTUB	110.00
1482-G	5 mh	$\pm 0.1$	320	3.83	0.82	230	890	INDUCTOVAT	110.00
1482-H	10 mh	$\pm 0.1$	220	8.3	0.76	155	600	INDUCTOVEX	110.00
1482-J	20 mh	$\pm 0.1$	144	14.9	0.84	116	450	INDUCTOWAD	110.00
1482-K	50 mh	$\pm 0.1$	87	37.4	0.84	73	280	INDUCTOWET	110.00
1482-L	100 mh	$\pm 0.1$	70	81	0.78	49	188	INDUCTOWIG	110.00
1482-M	200 mh	$\pm 0.1$	39.9	108	1.16	43	166	INDUCTOWOW	110.00
1482-N	500 mh	$\pm 0.1$	23.4	282	1.11	27	103	INDUCTOYAK	110.00
1482-P	1 h	$\pm 0.1$	15.3	616	1.02	18	70	INDUCTOYES	117.50
1482-Q	2 h	$\pm 0.1$	10.5	1120	1.12	13.4	52	INDUCTOBUG	140.00
1482-R	5 h	$\pm 0.1$	6.7	2920	1.08	8.3	32	INDUCTOBIN	170.00
1482-T	10 h	$\pm 0.1$	4.7	6380	.98	5.6	22	INDUCTOBAL	225.00

\*Representative values. Actual values given on certificate.







### TYPE 107 VARIABLE INDUCTOR

**USES:** The TYPE 107 Variable Inductors find their greatest uses in the laboratory as adjustable standards of moderate accuracy for measurements of self and mutual inductance, and as circuit elements in bridges, oscillators, and similar equipment.

**DESCRIPTION:** Rotor and stator coils are mounted concentrically. The effective inductance depends upon the position of the rotor with respect to the stator.

In most models stranded wire is used, in which the separate strands are insulated from one another. The coils are impregnated and baked in a high-melting-point material before being securely mounted on the phenolic panel.

Dial is direct reading in inductance for the series connection of the coils. Inductance for the parallel connection is one-fourth the value shown by the dial.

**FEATURES:**

- Continuous variation of inductance.
- Separate terminals for rotor and stator per-



mit either series or parallel connection.

- Calibrated in mutual as well as self-inductance.
- Rotor and stator inductances are made closely equal, to minimize circulating currents in the parallel connection.

### SPECIFICATIONS

**Inductance Ranges:** See table below. Dial is direct-reading in inductance for the series connection.

**Accuracy:** Series connection,  $\pm 1\%$  of full scale at 1 kc. Inductance for parallel connection is one-fourth the series value within 1% of the former. Mutual inductance accuracy is  $\pm 2.5\%$  of full-scale (mutual) value. The formula for mutual inductance is engraved on the nameplate.

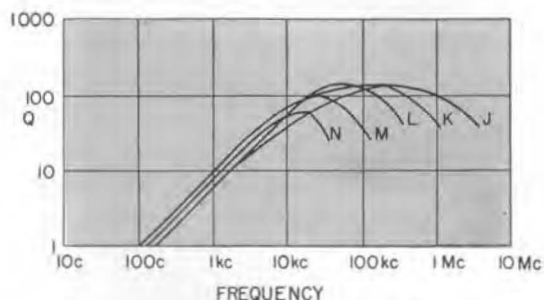

Storage factor,  $Q$ , versus frequency at full-scale, series connection.

**Frequency Characteristic:** The fractional increase in inductance with frequency will be  $f^2/f_0^2$  where  $f$  is the operating frequency and  $f_0$  the natural frequency, which

can be calculated from  $f_0 = \frac{1}{2\pi\sqrt{LC_0}}$ . Values of  $C_0$

are tabulated below. See plot for change in  $Q$  with frequency.

**Maximum Power and Current:** Current for 15 watts maximum dissipation, corresponding to a 40 C temperature rise, is given in the table below and is engraved on the nameplate.

**Dc Resistance:** See table below. These series connection values are engraved on the nameplate. For parallel connections the resistance is closely  $\frac{1}{4}$  the tabulated values.

**Terminals:** Standard  $\frac{3}{4}$ -inch spacing, jack-top binding posts provide separate connections to rotor and stator. Series and parallel connections are made by means of links.

**Mounting:** All units are mounted on phenolic panels and enclosed in nonshielded hardwood cabinets.

**Dimensions:**  $6\frac{1}{2}$  by  $6\frac{1}{2}$  by  $8\frac{3}{4}$  inches high, over-all (165 by 165 by 220 mm).

**Net Weight:** 5 pounds (2.3 kg), all ranges.

TYPE	SELF-INDUCTANCE		MUTUAL INDUCTANCE	TYPICAL $C_0$ VALUES		DC RESISTANCE $\Omega$	MAXIMUM CURRENT AMP	CODE WORD	PRICE
	SERIES	PARALLEL		SERIES	PARALLEL				
107-J	9-50 $\mu$ h	2.25-12.5 $\mu$ h	0-10.8 $\mu$ h	35 pf	57 pf	.05	16	HAREM	\$ 95.00
107-K	90-500 $\mu$ h	22.5-125 $\mu$ h	0-110 $\mu$ h	40 pf	72 pf	0.38	6	HARPY	95.00
107-L	0.9-5 mh	0.225-1.25 mh	0-1.1 mh	39 pf	73 pf	5.0	1.7	HARRY	98.00
107-M	9-50 mh	2.25-12.5 mh	0-11 mh	34 pf	41 pf	36	0.65	HOTEL	110.00
107-N	90-500 mh	22.5-125 mh	0-110 mh	34 pf	41 pf	450	0.17	HOVER	110.00





### TYPE 1481 INDUCTOR



**USES:** The TYPE 1481 Inductors have higher low-frequency values of storage factor  $Q$  than the TYPE 1482 Standard Inductors. They are useful at audio frequencies as working standards of self-inductance, although their accuracy of adjustment and their stability

are not as high as those of the TYPE 1482 Inductors, and, for some uses, allowance must be made for their current coefficient of inductance. For periodic checks of calibration, they can be compared with TYPE 1482 Standard Inductors on the TYPE 1632-A Inductance Bridge.

**DESCRIPTION:** These inductors are uniformly wound toroidal units on stabilized molybdenum-permalloy dust cores.

**FEATURES:**

- 16 values: 100  $\mu$ h–10 h.
- High  $Q$  — between 200 and 500, maximum; greater than 1 down to 6 cps.
- Electrostatically shielded.
- Small in size, low in cost.

### SPECIFICATIONS

**Accuracy:** See table below. Nominal value of inductance, adjustment accuracy, and current for 0.25% or 0.1% change in inductance are engraved on the case.

Calibration is at initial permeability and zero frequency, i.e., the inductance, measured at a frequency much less than the resonant frequency and with a current no greater than  $I_1$ , is extrapolated to zero current and zero frequency for the calibrated value.

**Stability:** The change in inductance is less than 0.25% per year when the inductors are adequately protected from extremes of current, temperature, and mechanical shock.

**Storage Factor,  $Q$ :** Figure 1 shows the variation of storage factor  $Q$  as a function of frequency for initial permeability, i.e., with no hysteresis loss.

**Current Coefficient of Inductance:** Percent change in inductance as a function of  $\frac{I}{I_1}$  is given in Figure 1, page 177, where  $I$  is the rms operating current and  $I_1$  the

current that would produce a 0.25% or 0.1% linear increase in  $L$ .

**Incremental Inductance:** Direct-current bias will reduce the initial inductance as shown in Figure 1, page 177.

**Temperature Coefficient of Inductance:** Approximately  $-25$  ppm per degree C, between 16 and 32 C.

**Safe Operating Limits:** (1) Maximum terminal voltage, 500 volts rms or (2) maximum rms current =  $100 I_1$ , whichever limit is lower.

**Distributed Capacitance:** Between 19 pf for the 100- $\mu$ h unit and 33 pf for the 5-h unit.

**Mounting:** Aluminum case.

**Terminals:** Jack-top binding posts, one grounded to case. A pair of double-ended plugs is furnished, for connection to jack-top binding posts.

**Dimensions:** Case, width  $3\frac{1}{8}$ , height  $3\frac{5}{8}$ , depth  $1\frac{5}{8}$  inches (80 by 95 by 40 mm); over-all height, including terminals,  $4\frac{5}{8}$  inches (120 mm).

**Net Weight:**  $\frac{7}{8}$  lb (0.4 kg).

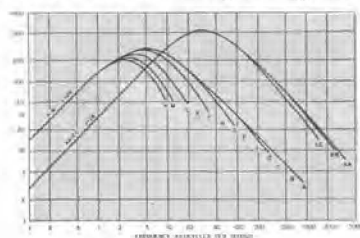
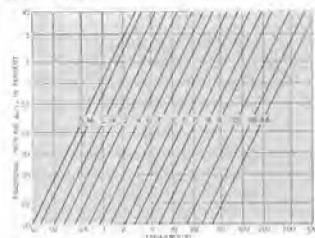

Figure 1.  $Q$  versus frequency for typical units.  
Figure 2. Percent increase in inductance versus frequency.



TYPE INDUCTOR	NOMINAL INDUCTANCE L	ADJUSTMENT ACCURACY %	RMS CURRENT, $I_1$ , FOR 0.25% INCREASE IN $L_0$ MA	RESONANT FREQUENCY $F_0$ KC	APPROX DC RESISTANCE $\Omega$	CODE WORD	PRICE
1481-AA	100 $\mu$ h	$\pm 2.0$	141*	3700	0.020	INDUCTOMAP	\$37.50
1481-BB	200 $\mu$ h	$\pm 2.0$	100*	2600	0.044	INDUCTOMUG	37.50
1481-CC	500 $\mu$ h	$\pm 1.0$	63*	1600	0.112	INDUCTOMEN	37.50
1481-A	1 mh	$\pm 1$	24	940	.043	INDUCTOSAP	37.50
1481-B	2 mh	$\pm 1$	17	660	.098	INDUCTOSET	37.50
1481-C	5 mh	$\pm 1$	11	420	0.25	INDUCTOSIG	37.50
1481-D	10 mh	$\pm 0.6$	7.6	300	0.44	INDUCTOSOT	37.50
1481-E	20 mh	$\pm 0.6$	5.4	210	0.95	INDUCTOSUM	37.50
1481-F	50 mh	$\pm 0.6$	3.4	130	2.31	INDUCTOPAL	37.50
1481-G	100 mh	$\pm 0.4$	2.4	91	4.3	INDUCTOPEG	40.00
1481-H	200 mh	$\pm 0.4$	1.7	64	7.2	INDUCTOPIIT	40.00
1481-J	500 mh	$\pm 0.4$	1.1	40	22	INDUCTOPOD	40.00
1481-K	1 h	$\pm 0.4$	0.76	28	40	INDUCTOPUB	40.00
1481-L	2 h	$\pm 0.4$	0.54	20	91	INDUCTORAM	42.50
1481-M	5 h	$\pm 0.4$	0.34	12.5	230	INDUCTORED	45.00
1481-N	10 h	$\pm 0.4$	0.24	10	416	INDUCTONAG	50.00

\* $I_1$  for 0.1% increase in  $L_0$ .





### TYPE 940 DECADE-INDUCTOR UNIT



**USES:** The TYPE 940 Decade-Inductor Units are convenient elements for use in wave filters, equalizers, and tuned circuits throughout the range of audio and low radio frequencies. As components in oscillators, analyzers, and similar equipment, they are especially useful during the preliminary design period, when the ability to vary circuit elements over relatively wide ranges is necessary to determine optimum operating values. As moderately precise standards of inductance they have values of low-frequency storage factor,  $Q$ , which are much larger than those of air-cored coils.

**DESCRIPTION:** Each unit is an assembly of four

TYPE 1481 Inductors (relative values, 1, 2, 2, 5) wound on molybdenum-permalloy dust cores, which are combined by switching to give the eleven successive values from 0 to 10. The decade switch has high-quality ceramic stator-and-rotor members and utilizes a well-defined ball-and-socket detent. All contacts are made of a solid-silver alloy and have a positive wiping action.

**FEATURES:**

- High values of storage factor  $Q$  are obtained in all models, with maximum values above 200.
- Toroidal construction minimizes external magnetic fields, so that the coils can be stacked without errors from mutual inductance. The toroids are nearly astatic to external magnetic fields.
- Aluminum covers provide electrostatic shielding and mechanical protection.
- Wax impregnation keeps out moisture.
- The switch is inherently reliable in extensive use and should not require bothersome cleaning or adjustment in service.

### SPECIFICATIONS

**Accuracy:** Each unit is adjusted so that its inductance at zero frequency and initial permeability will be the nominal value within the accuracy tolerance given in the following table:

Inductance per step	100 $\mu$ h	1 mh	10 mh	100 mh	1 h
Accuracy	$\pm 2\%$	$\pm 2\%$	$\pm 1\%$	$\pm 0.5\%$	$\pm 0.25\%$

**Frequency Characteristics:** For any specific operating frequency, Figure 2 shows the percentage increase in effective series inductance (above the geometric value when  $f = 0$ ) which is encountered with the extreme settings of each of the five Decade Inductor Units when the chassis is floating. Vertical interpolation may be used for intermediate settings.

**Change in Inductance with Current:** Fractional change

in initial inductance with ac current for each size of toroid is shown in the normal curves, Figure 1, in terms of the ratio of the operating current  $I$ , to  $I_1$ , the current for 0.25% change, solid line (0.1%, broken line). For ratios below unity, inductance change is directly proportional to current. Values of  $I_1$  listed below are approximate and are based on the largest inductor in the circuit for each setting.

**Incremental Inductance:** Dc bias current  $I_b$  will reduce

SWITCH SETTING	RMS $I_1$ (ma)				
	0.1% INCREASE	0.25% INCREASE			
		940-DD	940-E	940-F	940-G
1	141	24	7.6	2.4	0.76
2, 3, 4	100	17	5.4	1.7	0.54
5, 6, 7, 8, 9, 10	63	11	3.4	1.1	0.34

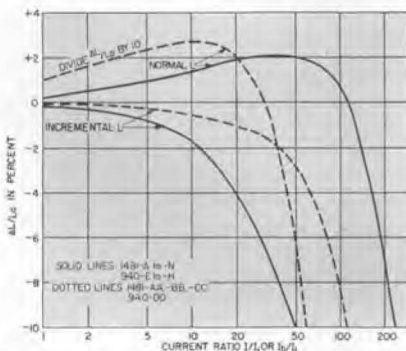

Figure 1. Percent change in normal and incremental inductance with ac and bias current. Incremental curve is limited to an ac excitation less than  $I_1$ .

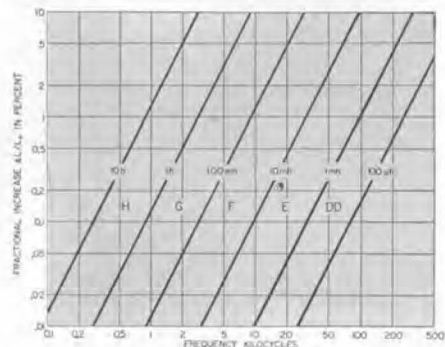

Figure 2. Change in effective inductance with frequency for the Type 940 Decade-Inductor Units.



# INDUCTORS

## DECADE



the initial inductance as shown in the incremental curve, Figure 1.

**Storage Factor, Q:** See Figure 3.

**DC Resistance:** Approximately 45 ohms per henry.

**Temperature Coefficient:** Approximately -25 ppm per degree C between 16 and 32 C.

**Maximum Voltage:** 500 volts rms. The switch will break the circuit at 500 volts if turned rapidly to the new setting, but voltages above 150 may cause destructive arcing if the switch is set between detent positions.

**Maximum Safe Current:** 70 times the pertinent  $I_1$  value.  
**Terminals:** Soldering lugs are provided. Circuit insulated from chassis.

**Mounting:** Each decade is complete with dial plate, knob, and mounting screws.

**Dimensions:** Width 8, height  $3\frac{1}{2}$ , depth  $4\frac{1}{4}$  inches (205 by 90 by 110 mm), over-all.

**Net Weight:**  $3\frac{1}{2}$  pounds (1.6 kg).

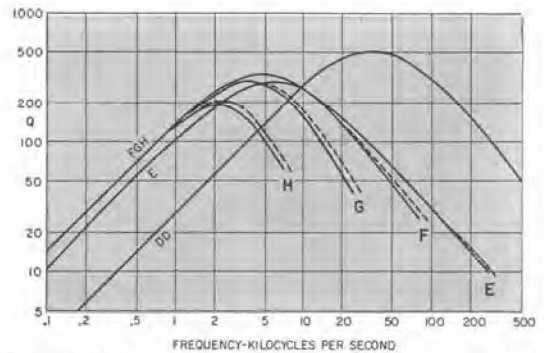

Figure 3. Variation of Q for the maximum inductance of each inductor. Dashed curves correspond to use with chassis floating.

TYPE	INDUCTANCE	CODE WORD	PRICE
940-DD	1 mh; in 100- $\mu$ h steps	INDUCTOCOP	\$110.00
940-E	.01 h; in .001-h steps	INDUCTOANT	110.00
940-F	0.1 h; in 0.01-h steps	INDUCTOBOY	110.00
940-G	1 h; in 0.1-h steps	INDUCTOCAT	110.00
940-H	10 h; in 1-h steps	INDUCTODOG	120.00

Note: Decade-resistor units and decade-capacitor units are listed on pages 151 and 166, respectively.

## TYPE 1490 DECADE INDUCTOR



**USES:** These boxes are particularly useful in circuit development and experimental filters, equalizers, and other networks.

**DESCRIPTION:** The TYPE 1490 Decade Inductor is an assembly of three or four TYPE 940 Decade-Inductor Units (described above) in a single metal cabinet. The units have no electrical connection to the panel, but a separate ground terminal is provided which can be connected to the adjacent "low" terminal, which leads to the smallest decade.

## SPECIFICATIONS

**Frequency Characteristics:** By interpolation in the accompanying plot, the percentage increase in effective series inductance (above the zero-frequency value,  $L_0$ ) may be obtained for any setting of the highest-valued decade used, when the LOW terminal is grounded to the cabinet.

**Zero Inductance:** Approximately 1  $\mu$ h.

**Terminals:** Jack-top binding posts.

**Mounting:** The decades are mounted on an aluminum panel in a gray metal cabinet.

**Dimensions:** TYPE 1490-C, width  $8\frac{1}{2}$ , height  $12\frac{3}{4}$ , depth  $5\frac{1}{2}$  inches (215 by 325 by 140 mm), over-all; TYPES 1490-D and -F, width  $8\frac{1}{2}$ , height  $16\frac{3}{4}$ , depth  $5\frac{1}{2}$  inches (215 by 425 by 140 mm), over-all.

**Net Weight:** TYPE 1490-C,  $16\frac{3}{4}$  lb (7.5 kg); TYPES 1490-D and -F  $21\frac{3}{4}$  lb (10 kg).

Other specifications are identical with those for the TYPE 940 Decade-Inductor Units.

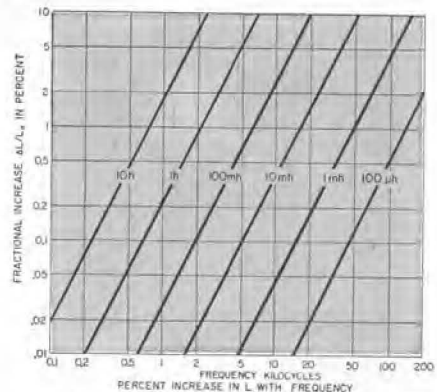

TYPE	CODE WORD	PRICE
1490-C	CLUMP	\$360.00
1490-D	COACH	460.00
1490-F	FOCUS	450.00

Note: The TYPE 1432 Decade Resistors and the TYPE 1419 Decade Capacitors can be found on pages 149 and 168, respectively.

# INSTRUMENTS FOR THE MEASUREMENT OF SOUND AND VIBRATION



Measurement is an essential element in the efficient evaluation and control of noise and vibration. The necessary measurements are made possible by General Radio's comprehensive line of instruments. These instruments are a result of a continuing development program since 1933, when General Radio announced its first noise meter. The standard sound-level meter, which succeeded the noise meter, is the basic sound-measuring instrument and has been improved in each successive model in performance, in convenience, and in versatility, culminating in the TYPE 1551-C Sound-Level Meter, which meets the American Standard on Sound-Level Meters\*.

An excellent, general-purpose PZT microphone is now supplied as standard equipment. This stable and rugged microphone has a smooth frequency response and is relatively unaffected by normal temperature changes. It can be mounted directly on the instrument or separately with connection by extension cable when it is necessary to avoid the effects of the observer on the acoustical measurement. Other transducer systems are available for specialized measurements.

The TYPE 1555-A Sound-Survey Meter is a simplified version of the sound-level meter, particularly designed for convenience in use, small size, and low cost.

Either one of these instruments can be used to measure over-all level, the first important measure of a noise. A frequency analysis is also desirable to estimate the effects of the noise, to track down the source, and to determine efficient control measures. The TYPE 1551-C Sound-Level Meter provides an output that is the amplified electrical replica of the acoustical signal at the microphone. This output signal has a wide dynamic range and its frequency spectrum can be analyzed by the General Radio analyzers shown on the next page. These include the broad-band TYPE 1550-A Octave-Band Analyzer and the TYPE 1554-A Sound and Vibration Analyzer with both narrow-band and third-octave responses.

Satisfactory noise measurements depend on measuring equipment that is kept in proper operating condition. Although the instruments are inherently reliable and stable, after long periods of use their performance may change. In order to ensure that important changes will be discovered and corrected, the TYPE 1552-B Sound-Level Calibrator has been developed.

It provides a calibration of the over-all system at 400 cps. When driven by a 400-cycle oscillator at a 2-volt level and mounted on any of the microphones shown on the following page it supplies a known acoustic signal to the microphone. The TYPE 1307-A Transistor Oscillator is a convenient 400-cycle source.

The measurement of impact noise, which has previously required extensive instrumentation including an oscilloscope, is now possible with a simple setup consisting of the TYPE 1551-C Sound-Level Meter and the TYPE 1556-B Impact Noise Analyzer.

With these instruments, one can make the measurements necessary for evaluating practically any industrial noise problem. They can be used by nontechnical personnel and are designed for long life and trouble-free operation. The use of these and other noise-measuring instruments is discussed thoroughly in the *Handbook of Noise Measurement*, published by the General Radio Company, and available at one dollar a copy, postpaid. A *Primer of Noise Measurement*, an elementary treatise, is free on request.

Vibration-measuring equipment includes the TYPE 1553-A Vibration Meter to measure acceleration, velocity, displacement, and jerk of a vibrating element; the TYPE 1554-A Sound and Vibration Analyzer to analyze the vibration; and the TYPE 1560-P11 Vibration Pickup System to convert the sound-level meter to a vibration meter. Calibration of these instruments is easily checked by the TYPE 1557-A Vibration Calibrator, a self-contained electromagnetic shaker.

Another important group of vibration instruments are stroboscopes (see page 195), which permit vibrating objects to be viewed intermittently and produce the optical effect of slowing down or stopping a periodic vibration. The TYPE 1521-A Graphic Level Recorder can record the level and spectral distribution of sound and vibration, operating from the output of the Sound-Level Meter, the Vibration Meter, or one of the analyzers. The TYPE 1390-B Random Noise Generator and the TYPE 1304-B Beat-Frequency Audio Generator can drive transducers for observing the vibratory or acoustical response of various systems.

\*American Standard Specification for General-Purpose Sound-Level Meters, S 1.4-1960; American Standards Association, 10 East 40th Street, New York 16, New York.

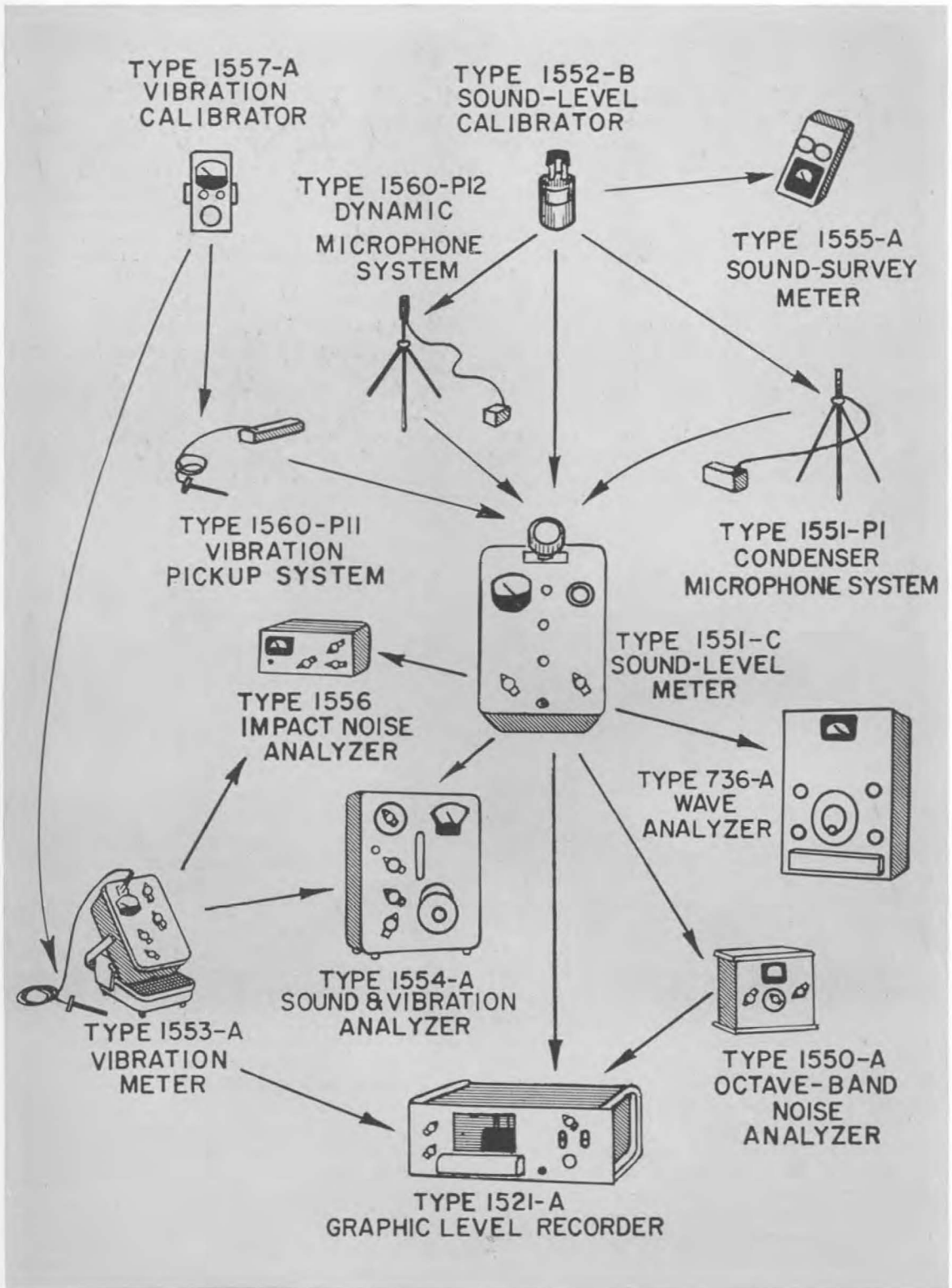

## TYPE 1555-A SOUND-SURVEY METER

The TYPE 1555-A Sound-Survey Meter is an inexpensive, pocket-sized instrument for use in general survey measurements. Some of the many uses of this versatile meter are:

Measurement of noise levels in homes, offices, factories, and outdoor locations;

Measurement of noise levels produced by appliances, office equipment, and machinery;

Measurement of sirens and other emergency warning systems;

Measurement of level and dispersion pattern of reproduced sound from public address systems, theaters, and home sound systems;

Surveys by field engineers for acoustic material companies;

Acoustic experiments in physics classes;

Measurements of cross-over characteristics and dynamic range of high-fidelity music reproducing systems.

Frequency response measurements on loudspeakers and rooms;

Loudness checks on speakers and singers, at rehearsals and in classes.

**DESCRIPTION:** The TYPE 1555-A Sound-Survey Meter consists of a nondirectional microphone, a continuously adjustable calibrated attenuator, a stable amplifier with three weighting networks, and an easily read indicating meter. The entire assembly, including microphone and batteries, is housed in a rugged, two-piece aluminum case. The attenuator and weighting-network selector are fingertip-operated, per-



mitting operation of the instrument with one hand.

For more accurate measurements and for greater flexibility, the TYPE 1551-C Sound-Level Meter (page 182) is recommended.

**FEATURES:**

- Small enough to fit in pocket.
- Can be used set on a table, mounted on a tripod, or held in the hand.
- Miniature in size, yet uses standard and well-tested components.

**SPECIFICATIONS**

**Range:** 40 to 136 db (re .0002  $\mu$ bar).

**Frequency Characteristic:** Any one of three different frequency characteristics can be selected by the FUNCTION switch. In the C weighting positions the frequency response is substantially flat from 40 to 8000 cps.

The A and B weighting positions follow the 40-70-db contours established as the standard of weighting for sound-level meters. By comparing measurements in different weighting positions, one can estimate the relative importance of low-frequency components in the sound being measured.

**Accuracy:** The gain of the amplifier is so set that the sensitivity of the instrument is correct at 400 cps within  $\pm 1$  db.

**Stability:** The amplifier is stabilized by feedback to minimize the effect of changes in battery voltage. Temperature and humidity changes over the normal range of room conditions have no noticeable effect. The temperature coefficient of the sound-level indication is low, in the order of .03 db/ $^{\circ}$ F.

**Operating Limits:** The maximum safe operating tempera-

ture of the instrument is 115 F. Temperatures above 130 F will permanently damage the Rochelle-salt crystal in the microphone.

**Microphone:** A crystal-diaphragm-type microphone is mounted at the top of the instrument.

**Batteries:** One 1½-volt size C flashlight battery (Rayovac 11P or equivalent) and one 30-volt hearing-aid battery (Eveready 413E or equivalent) are supplied.

**Tube Complement:** Two CK512-AX and two CK533-AX tubes are supplied.

**Cabinet:** Aluminum, finished in crackle, with a standard ¼-20 threaded tripod mount. A leather "ever-ready" carrying case (not supplied with the Sound-Survey Meter, but available separately) permits operation of the instrument without removal from the case.

**Dimensions:** Height 6, width 3⅛, depth 2½ inches (155 by 80 by 65 mm), over-all.

**Net Weight:** 1 lb 14 oz (0.85 kg) with batteries.

*The Primer of Noise Measurement*, free on request, discusses sound and noise measurements possible with this instrument.

TYPE		CODE WORD	PRICE
1555-A	Sound-Survey Meter .....	MISER	\$165.00
	Set of Replacement Batteries .....	MISERADBAT	1.95
1555-P2	Leather Carrying Case .....	CAGED	10.00



## TYPE 1551-C SOUND-LEVEL METER



**USES:** The TYPE 1551-C is an accurate, portable instrument designed to meet American Standards Association specifications. In its primary function as a noise meter, this is the accepted instrument for the measurement of both product noise and environmental noise, by industry, commercial laboratories, regulatory bodies, and noise-abatement groups. Typical users include:

Machine and appliance manufacturers, in industrial and development laboratories as well as on the production line. The Sound-Level Meter provides a means of establishing noise standards and of accepting or rejecting products on the basis of noise tests;

Acoustical engineers and physicists, for the measurement of noise produced by machinery and for determining the acoustic properties of buildings, vehicles, and materials;

Industrial hygienists and psychologists, in surveys of the psychological and physiological effects of noise and for the determination of satisfactory noise environments in factories and offices.

In addition to its primary use as a self-contained sound-level meter, the TYPE 1551-C

is the heart of a complete sound-measuring system, comprised of the accessories described elsewhere in this section. These include spectrum analyzers, special-purpose microphones, and vibration pickups. Many other accessories, such as graphic level recorders and tape recorders, can also be operated from the output of the TYPE 1551-C.

The Sound-Level Meter can also be used as a portable amplifier, attenuator, and voltmeter for laboratory measurements in the audio-frequency range.

Many applications of the TYPE 1551-C Sound-Level Meter are described in detail in the *Handbook of Noise Measurement*, a copy of which is supplied with each instrument.

**DESCRIPTION:** The TYPE 1551-C Sound-Level Meter consists of a nondirectional microphone, a calibrated attenuator, an amplifier, standard weighting networks, and an indicating meter. The complete instrument, including batteries, is mounted in an aluminum case. The microphone is mounted on a swivel, which permits its use in either a vertical or a horizontal position. When not in use, the microphone folds down into a storage position, automatically disconnecting batteries. An ac power supply unit is available.

### FEATURES:

- Small, compact, and portable — weighs less than 8 pounds with batteries.
- Simple to operate.
- Meets all applicable standards of American Standards Association, American Institute of Electrical Engineers, and Acoustical Society of America.
- Wide dynamic range.
- Two-speed meter movement permits measurement of either steady or fluctuating sound.
- Wide sound-level range — from 24 to 150 db.
- Uses readily available batteries.
- Wide frequency response of amplifiers and panel meter — from 20 cps to 20 kc.
- Low internal noise level.
- Internal calibration system for standardizing amplifier gain.
- Quasi-rms meter; indication is essentially rms for all waveforms except short impact pulses.





## SPECIFICATIONS

**Sound-Level Range:** From 24 to 150 db (re .0002 microbar).

**Frequency Characteristics:** Any one of four response characteristics, A, B, C, or 20 kc, can be selected by a panel switch.

The A, B, and C weighting positions are in accordance with American Standard Association specifications on sound-level meters.

The 20-kc position allows the use of the complete frequency response of the sound-level meter's amplifier, which is flat from 20 cps to 20 kc, so that complete use can be made of wide-range microphones such as the General Radio TYPE 1551-P1 Condenser Microphone Systems.

**Microphone:** The microphone is a highly stable PZT ceramic type. Condenser and dynamic microphones are available as accessories. See pages 184 and 186.

**Sound-Level Indication:** Sound level is indicated by the sum of the meter and attenuator readings. The clearly marked, open-scale meter covers a span of 16 db with calibration from -6 to 10 db. The attenuator is calibrated in 10-db steps from 30 to 140 db above the standard reference level.

**Output:** An output of 1 volt across 20,000 ohms (when the panel meter is at full scale) is available at an output jack. The output can be used to drive frequency analyzers, recorders, and oscilloscopes. A phone plug to TYPE 274 connecting cable (TYPE 1560-P95) is available.

**Input Impedance:** 25 megohms in parallel with 50 pf.

**Output Impedance:** 7000 ohms.

**Meter Damping:** The panel meter has two different damping characteristics, either FAST or SLOW response being selected by a panel switch. The meter ballistics agree with current ASA standards.

**Calibration:** Built-in calibration circuit standardizes the sensitivity of the electrical circuits in the sound-level meter.

**Calibration Accuracy:** After standardization, sound-level measurements are within  $\pm 1$  db at 400 cps, as specified in ASA standards. The TYPE 1552-B Sound-Level Calibrator (page 187), is available for making periodic acoustic checks on the over-all calibration, including microphone.

**Temperature and Humidity Effects:** Readings are independent (within 1 db) of temperature and humidity over normal ranges of room conditions.

**Power Supply:** Two 1½-volt size D flashlight cells (Rayovac 2LP or equivalent) and one 67½-volt battery (Burgess XX-45 or equivalent) are supplied. A 115-volt ac power supply, the TYPE 1262-B, is available.

**Tube and Transistor Complement:** Four CK512-AX, two CK6418, one 2N1372 transistor.

**Accessories Supplied:** Telephone plug.

**Accessories Available:** TYPE 1551-P2 Leather Case, which permits operation of the instrument without taking it from the case. TYPE 1560-P95 Connecting Cable, for connecting output to TYPE 1521-A Graphic Level Recorder. For other accessories, see pages 184 to 191.

**Cabinet:** Shielded aluminum, finished in gray crackle.

**Dimensions:** Height 9¼, width 7¼, depth 6⅝ inches (235 by 185 by 160 mm), over-all.

**Net Weight:** 7¾ lb (3.5 kg) with batteries; 9¾ lb (4.4 kg) including leather case.

*General Radio Experimenter*, Vol. 32, No. 16, October, 1958.



The Type 1551-C Sound-Level Meter with the microphone in the storage position, and batteries automatically disconnected.



The Sound-Level Meter is here operated while in its leather carrying case, with the microphone in the horizontal operating position.



The Type 1551-C Sound-Level Meter can be ac-operated by means of the Type 1262-B Power Supply, which plugs directly into the base of the Sound-Level Meter.

TYPE		CODE WORD	PRICE
1551-C	Sound-Level Meter .....	MIMIC	\$415.00
1262-B	Power Supply .....	MAYOR	95.00
	Set of Replacement Batteries .....	MIMICDBAT	3.90
1551-P2	Leather Carrying Case .....	CALYX	24.50
1560-P95	Connecting Cable .....	CONEC	3.00





## TYPE 1551-P1 CONDENSER MICROPHONE SYSTEM

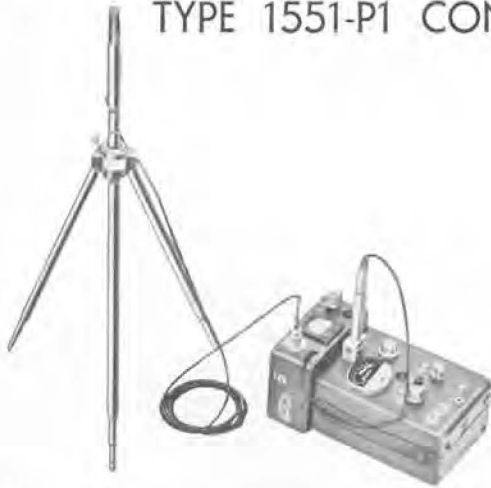

**USES:** The TYPE 1551-P1L (for normal-level measurement) and 1551-P1H (for high-level measurement) Condenser Microphone Systems are designed for use with the TYPE 1551-C Sound-Level Meter for measuring sound levels over wide frequency ranges. These microphones are not damaged by high sound lev-

els or by high temperatures. Applications include:

Measurement of high-frequency and high-level noises produced by such noise sources as air streams, woodworking and metalworking machinery, turbines, and jet engines.

General-purpose sound-level measurements where ambient temperature and sound level are high.

Measurements on high-fidelity sound systems over the full audio spectrum.

**DESCRIPTION:** The TYPE 1551-P1L Condenser Microphone System uses an Altec 21-BR-150 microphone and measures sound-pressure levels up to 155 db; the TYPE 1551-P1H, which uses a 21-BR-180 microphone, measures levels up to 170 db.

The microphone base houses a subminiature preamplifier tube. A battery-operated power supply provides preamplifier filament and plate power and polarizing voltage for the microphone. An extension cable, a tripod, and a leather carrying case are supplied.

### SPECIFICATIONS

**Frequency Response:** 20 cps to 18 kc with either microphone. A typical response curve is shown at right.

**Calibration:** The output level as a function of frequency is measured in our laboratory by comparison with a standard microphone. The measured level at 400 cps is supplied, and a calibration curve is included with each instrument.

**Output Impedance:** 6500 ohms (typical).

**Direct Use with Analyzers:** These assemblies can supply a signal directly to either the TYPE 1550-A Octave-Band Noise Analyzer or the TYPE 1554-A Sound and Vibration Analyzer, provided that the levels of the measured components are above the following indicated values:

	1551-P1H	1551-P1L
Type 1550-A	85 db	70 db
Type 1554-A	65 db	50 db

A TYPE 1552-B Sound-Level Calibrator is necessary for absolute level calibration.

**Maximum Sound-Pressure Level:**

For the TYPE 1551-P1L Condenser Microphone Assembly, nonlinear distortion is below 1% at levels up to 135 db, and less than 10% at 155 db.

For the TYPE 1551-P1H High-Level Microphone Assembly, nonlinear distortion is below 1% up to 150 db and below 10% up to 170 db.

**Minimum Measurable Sound-Pressure Level**

TYPE 1551-P1L: 50 db (re .0002  $\mu$ bar)

TYPE 1551-P1H: 65 db (re .0002  $\mu$ bar).

**Temperature and Humidity:** Maximum recommended operating temperature of the microphone in its probe is 212 F. The microphone is not damaged by exposure to high humidity, but prolonged exposure may cause elec-

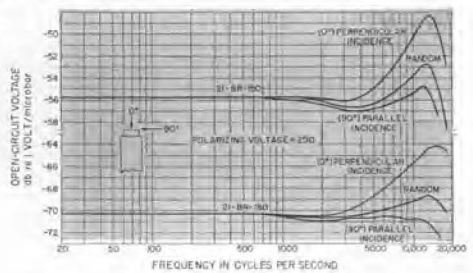

trical leakage and render it temporarily inoperative.

**Batteries:** One 1½-volt size D flashlight cell (Rayovac 2LP or equivalent) and one 300-volt B battery (Eveready 493, Burgess V-200 or equivalent) are supplied. Batteries should last at least 150 hours under normal use.

**Tube Complement:** Two Raytheon CK512-AX.

**Mounting:** The microphone on its base plugs into one end of a 10-foot cable and will slip into receptacle on the tripod. The other end of the cable is connected to the power supply unit, which fastens to one end of the Sound-Level Meter.

**Components and Accessories Supplied:** Microphone base assembly, cable assembly, power supply, microphone, microphone cap, carrying case, and tripod.

**Dimensions:** Leather carrying case is approximately 7 inches high, 5½ inches long, 8½ inches wide (180 by 140 by 220 mm).

**Net Weight:** Complete in carrying case, 7¼ lb (3.3 kg).

TYPE		CODE WORD	PRICE
1551-P1L	Condenser Microphone System . . . . .	NONAL	\$398.00
1551-P1H	High-Level Microphone Assembly . . . . .	NATAL	398.00
	Set of Replacement Batteries . . . . .	NONALDBAT	11.20



# STANDARD ACCESSORIES FOR THE SOUND-LEVEL METER

The following accessories are available for use with the TYPE 1551-C Sound-Level Meter to increase its field of application and to adapt it for specialized types of measurement. These

accessories can also be used with older Sound-Level Meters, TYPES 759-B, 1551-B, and 1551-A, although in certain instances, as indicated, adaptors are required.

## TYPE 1560-P11 VIBRATION PICKUP SYSTEM

The TYPE 1560-P11 Vibration Pickup System consists of a TYPE 1560-P51 Vibration Pickup and a TYPE 1560-P21 Control Box. The Vibration Pickup is an inertia-operated ceramic device which generates a voltage proportional to the acceleration of the vibrating body. By means of integrating networks in the control box, voltages proportional to velocity and displacement can also be delivered to the sound-level meter. The desired response is selected by means of a three-position switch on the control box.



The vibration pickup and control box plug into the Sound-Level Meter in place of the microphone. The control box fastens to one end of the Sound-Level Meter, as shown above.

### SPECIFICATIONS

**Calibration:** The db readings on the sound-level meter can be converted into absolute values of displacement, velocity, or acceleration by means of calibration data supplied.

**Range:** The range of measurement of the pickup and con-

trol box when used with the TYPE 1551-C, 1551-B, 1551-A, or 759-B Sound-Level Meter is approximately as follows:

Rms Displacement, 100 microinches, minimum.

Rms Velocity, 3000 microinches per second, minimum. The upper limit of velocity and displacement measurements depends on frequency, and is determined by the maximum acceleration permissible before nonlinearity occurs (100 g).

Rms Acceleration, 0.3 to 39,000 in./sec/sec(100 g).

**Pickup Sensitivity:** 40 mv per g.

**Pickup Capacitance:** 7000 pf.

**Net Weight:** TYPE 1560-P51 Vibration Pickup 1.6 oz (45 g); pickup plus 5-ft cable, probe, and tips, 8 oz (230 g). TYPE 1560-P21 Control Box, 1 lb 3 oz (0.6 kg).

Over-all frequency response characteristic of the Vibration Pickup System used with the Sound-Level Meter, and of the Vibration Pickup only.

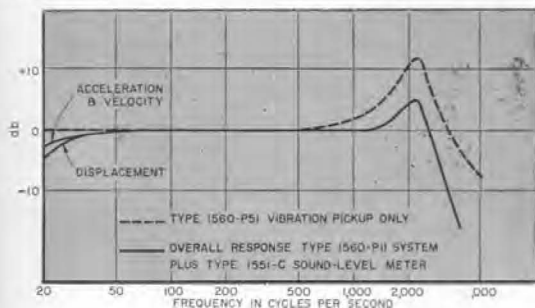

TYPE	DESCRIPTION	CODE WORD	PRICE
1560-P11	Vibration Pickup System	PIKUP	\$140.00

## TRIPOD AND EXTENSION CABLE

For measurements where the microphone must be located at a distance from the meter, the TYPE 1560-P12 Dynamic Microphone System (page 186) is recommended. However, a 25-foot extension cable (TYPE 1560-P73) and

tripod (TYPE 1560-P32) for mounting the TYPE 1560-P3 Microphone (supplied with the TYPE 1551-C Sound-Level Meter) are available as the TYPE 1560-P34 Tripod and Extension Cable.

TYPE	DESCRIPTION	CODE WORD	PRICE
1560-P34	Tripod and Extension Cable	KABLE	\$41.50



### TYPE 1560-P12 DYNAMIC MICROPHONE SYSTEM

For some measurements, particularly where a long cable must be used between microphone and meter, a dynamic microphone is preferable to the standard microphone supplied with the Sound-Level Meter. The TYPE 1560-P12 Dynamic Microphone System includes, in addition to the microphone, a 25-foot cable, a transformer to increase the output voltage from the microphone for use with the Sound-Level Meter, and a tripod. The transformer is connected to the Sound-Level Meter in place of the standard microphone, and the microphone cable plugs into the transformer.



Transformer fastens to one end of Sound-Level Meter, and is connected in place of microphone, as shown.

### SPECIFICATIONS

**Sensitivity:** Open-circuit output of typical microphone is 90 db below one volt per microbar, and of microphone plus transformer is 60 db below one volt per microbar. The sensitivity is satisfactory for direct reading of sound-pressure level by the TYPE 1551-C, TYPE 1551-B, TYPE 1551-A\*, and TYPE 759-B\* Sound-Level Meters.

**Direct Use with Analyzers:** Microphone output can be supplied directly to the TYPE 1550-A† Octave-Band Noise Analyzer provided the level of the measured component is above 70 db (re 0.0002  $\mu$ bar) or to the TYPE

1554-A† Sound and Vibration Analyzer, provided the level of measured components is above 50 db. (A TYPE 1552-B Sound-Level Calibrator is necessary to obtain absolute level.)

**Maximum Safe Sound-Pressure Level:** Sound-pressure levels above 140 db can damage the microphone.

**Calibration:** Output level is checked in our laboratories at several frequencies against a standard microphone that is calibrated periodically. The level at 400 cps is stated.

**Cable Correction:** No correction is necessary for the 25-foot cable supplied or the TYPE 1560-P72B 100-foot cable.

**Components:** TYPE 1560-P2 Dynamic Microphone, TYPE 1560-P22 Transformer Assembly, TYPE 1560-P72 Cable, TYPE 1560-P32 Tripod.

**Net Weight:** 5 1/4 pounds (2.4 kg); microphone only, 8 1/2 oz (250 g).

\*TYPE 1560-P92 Adaptor required.

†TYPE 1560-P93 Adaptor required.

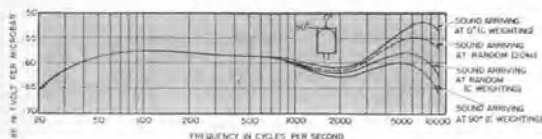

Typical response curves of the Type 1551-C Sound-Level Meter with Type 1560-P12 Dynamic Microphone System.

TYPE		CODE WORD	PRICE
1560-P12	Dynamic Microphone System.....	DYNAM	\$210.00
1560-P72B	Extra 100-foot cable.....	ADAPTORWAY	30.00
1560-P92	Adaptor Assembly.....	ADAPTORBUG	12.50
1560-P93	Adaptor Assembly.....	ADAPTORCOP	12.50

### HANDBOOKS

The *Handbook of Noise Measurement*, published by General Radio Company, covers thoroughly the subject of noise and vibration measurement. Authors are Dr. A.P.G. Peterson and Ervin E. Gross, Jr., of the General Radio Engineering Staff. Copies of this handbook are available from General Radio at a price of \$1.00 each, postpaid, in the United States and Canada.

A *Primer of Noise Measurement* presents an elementary discussion of sound measurements, written for those with little or no background in the field. Copies are available free on request.





## TYPE 1552-B SOUND-LEVEL CALIBRATOR

**USES:** The TYPE 1552-B Sound-Level Calibrator supplies an acoustic signal of known sound-pressure level for checking the over-all performance of a sound-level meter, *including its microphone*. The calibrator fits over any one of several microphones (see list in Specifications) and can be used to calibrate the TYPE 1550-A Octave-Band Noise Analyzer or TYPE 1554-A Sound and Vibration Analyzer when they are used directly with the microphones listed. The Calibrator can also be used to supply an acoustic reference level for audio systems.

The TYPE 1307-A Transistor Oscillator serves as both oscillator and level indicator when used with the Sound-Level Calibrator.

**DESCRIPTION:** A small, stable loudspeaker is mounted in one end of a cylindrical enclosure. The other end of the enclosure fits over the microphone. Acoustical coupling between the speaker and microphone is fixed by chamber and microphone dimensions. The calibrator provides acoustical shielding and a high test level to reduce effects of ambient noise during calibration. Calibration checks under these conditions are accurate and readily repeatable.

**FEATURES:**

- Good accuracy,  $\pm 1$  db at 400 cps. Very stable, low temperature coefficient and long-term stability.
- Easily portable — Calibrator and battery-



Calibrator fits over Microphone of Type 1551-C Sound-Level Meter. At right is Type 1307-A Transistor Oscillator.

powered TYPE 1307-A Oscillator together weigh under 3 pounds.

- Fits many microphones.

### SPECIFICATIONS

**Accuracy of Calibration:**  $\pm 1$  db at 400 cps.

**Microphones:** The Calibrator can be used on the following microphones without the need of special adaptors:

Shure Brothers TYPE 98108 (General Radio TYPE 1560-P3), supplied on TYPE 1551-C Sound-Level Meter, General Radio TYPE 1560-P2, supplied with the TYPE 1560-P12 Dynamic Microphone System,

Shure Brothers TYPE 98B99 (General Radio TYPE 1560-P1), supplied on TYPE 1551-B Sound-Level Meter, Shure Brothers TYPE 9898, supplied on TYPE 759-B and 1551-A Sound-Level Meters,

TYPE 1555-A Sound-Survey Meter, TYPE 1551-P1L and -P1H Condenser Microphone Systems,

TYPE 759-P25 Dynamic Microphone System, Western Electric TYPE 640-AA Microphone, Kellogg Microphone.

**Terminals:** Input terminals are TYPE 938 Binding Posts, spaced  $\frac{3}{4}$  inch to fit TYPE 274-MB Double Plug.

**Accessory Required:** A 400-cps source, with output con-

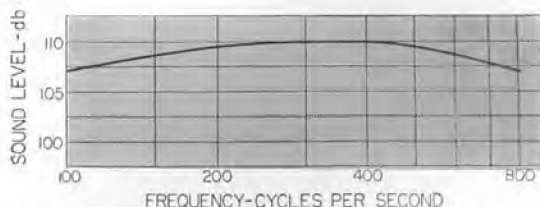

Frequency characteristic of Type 1552-B Sound-Level Calibrator.

rol and voltmeter. The TYPE 1307-A Transistor Oscillator, a battery-operated instrument with self-contained voltmeter, is recommended (see page 106).

**Accessory Available:** TYPE 1560-P31 Leather Carrying Case, for Calibrator and TYPE 1307-A Oscillator.

**Dimensions:** Length  $4\frac{1}{2}$ , diameter  $2\frac{1}{2}$  inches (115 by 65 mm), over-all.

**Net Weight:** 14 ounces (0.4 kg).

TYPE		CODE WORD	PRICE
1552-B	Sound-Level Calibrator . . . . .	NATTY	\$52.50
1307-A	Transistor Oscillator (see page 106) . . . . .	OMEGA	97.00
1560-P31	Leather Carrying Case, for Calibrator and Oscillator . . . . .	CANOE	12.00



TYPE 1556-B IMPACT NOISE ANALYZER



**USES:** The characteristics of impact-type sounds and of impulse noises in data-transmission systems can be measured by the Impact Noise Analyzer. Impact noises that cannot be measured with conventional noise-measuring equipment but whose characteristics can be measured with the Impact Noise Analyzer include those produced by punch presses, forging hammers, fire alarms, pile drivers, office machinery, and similar equipment. From the standpoint of hearing damage, some of these sounds constitute a serious problem for industry. They have hitherto been measurable only by complicated methods employing oscilloscopes.

The two characteristics of impact sounds that seem most significant are the peak amplitude and the duration, or decay time. This

analyzer measures both of these quantities and also a quasi-peak value that is useful in determining the variation among peak values in repetitive impacts.

The Impact Noise Analyzer is widely used in the measurement of impulse-type circuit noise in communications systems. A push-button reset facilitates making the many observations required.

The Impact Noise Analyzer operates from the output of a Type 1551 Sound-Level Meter and, when a vibration pickup is used in place of the microphone on the Sound-Level Meter, will measure vibration impact characteristics. It will also operate from octave-band analyzers and tape recorders.

**DESCRIPTION:** A battery-operated, degenerative, transistor amplifier simultaneously drives three ac voltmeter circuits, which comprise rectifiers, storage capacitors, and a common dc electronic voltmeter. The electrical storage system (a capacitor charged by a rectifier) makes it possible to measure three characteristics — peak, quasi-peak, and time-average — of an impact with a single indicating meter. Peak value is the maximum sound pressure level reached by the noise; quasi peak is a continuously indicating measure of the high sound-pressure levels reached just before the time of indication; time average is a measure of the average level over a predetermined period of time, which, when subtracted from peak level, is a measure of the time duration of the sound.

SPECIFICATIONS

**Input:** Any voltage from 1 to 10 volts for normal range. Inputs below 1 volt reduce the range of reading.

**Input Impedance:** Between 25,000 and 100,000 ohms, depending on the setting of the LEVEL control.

**Frequency Range:** 5 cps to 20 kc.

**Level Indication:** Meter calibrated in db from -10 to +10. Attenuator switch increases range by 10 db.

**Peak Reading:** Rise time is less than 50 microseconds for a value within 1 db of peak value (for rectangular pulses). Storage time at normal room temperature is greater than 10 seconds for a 1-db change in value.

**Quasi-Peak Reading:** Rise time of less than 1/4 millisecond and decay time of 600 ±120 milliseconds for rectifier circuit.

**Time-Average Reading:** Charge time of rectifier circuit selected by seven-position switch, having times of .002, .005, .01, .02, .05, 0.1, and 0.2 second for the resistance-

capacitance time constant. Storage time at normal room temperature is greater than 1 minute for a 1-db change in value.

**Accessories Required:** A sound-level meter or frequency analyzer to supply the analyzer input.

**Input Terminals:** Cord with phone plug at one end.

**Batteries:** One 1 1/2-volt size D flashlight cell (Rayovac 2LP or equivalent) and one 45-volt B battery (Burgess XX30 or equivalent) are supplied. Typical battery life is 100 hours.

**Transistors:** Two 2N1372 and one 2N1374.

**Tube Complement:** One Type CK6418.

**Cabinet:** Aluminum; carrying case supplied. Case fastens directly to one end of Type 1551 Sound-Level Meter.

**Dimensions:** Height 4 1/4, width 7 1/2, depth 6 1/2 inches (110 by 195 by 165 mm).

**Net Weight:** 4 1/2 lb (2.1 kg); carrying case, 1 lb (0.5 kg).

TYPE		CODE WORD	PRICE
1556-B	Impact Noise Analyzer . . . . .	MEDAL	\$220.00



## TYPE 1554-A SOUND AND VIBRATION ANALYZER

**USES:** The Sound and Vibration Analyzer is designed to measure the amplitude and frequency of the various frequency components in sounds or vibrations, in conjunction with a sound-level meter or vibration meter. It is useful for measurement not only of line (single-frequency) components but also of continuous (noise) components of the spectrum. Its narrow bandwidth (8%, constant with frequency) is sufficient to embrace the frequency fluctuation arising from normal variations in speeds of engines, machines, and appliances; the alternate, one-third-octave bandwidth (1.26 to 1) is used for the measurement of wide-band spectra.

The combination of TYPE 1554-A Analyzer and TYPE 1521-A Graphic Level Recorder can be used to record the spectrum of an input voltage wave. Special chain link unit and chart paper are available (page 143) for use of the TYPE 1554-A with the TYPE 1521-A.

The Sound and Vibration Analyzer can be used in conjunction with the TYPE 1390-B Random-Noise Generator (page 123) for transfer and reverberation measurements using one-third octaves of random noise.

High sensitivity, wide dynamic range, 8% bandwidth, and low-frequency range (down to 2.5 cps) make the TYPE 1554-A a very useful general-purpose wave analyzer at audio and subaudio frequencies.

**DESCRIPTION:** The Sound and Vibration Analyzer is a tunable voltmeter whose bandwidth is a constant percentage of the center frequency. It consists of two RC-tuned selective amplifiers connected in cascade, and input and output circuits. The selective amplifiers can be tuned synchronously or staggered to give narrow (8%) or one-third octave bandwidth, respectively. They also can be switched to nonselective (all-pass) operation for convenient measurement of the entire input signal before analysis into its components. The ac output signal is available at a jack on the panel for connection to headphones or to a recorder. Special chart paper, TYPE CTP-554, is available for use with the TYPE 1521-A Graphic Level Recorder for recording the output of the analyzer at frequencies above 25 cps. A TYPE 1560-P95 Connecting Cable (page 183) can be used to connect the output of the Analyzer to the input terminals of the TYPE 1521-A Recorder.

### FEATURES:

- A sound analyzer and a vibration analyzer combined in one instrument.
- Wide frequency range: 2.5 to 25,000 cps.
- 10-to-1 span on each frequency range.
- Choice of three bandwidths: narrow, one-third octave, or all-pass.
- Adjustable decibel dial may be set so ana-





lyzer is direct-reading in sound-pressure level, one-third-octave band level, etc.

- Portable and battery-powered.
- Can be calibrated for amplitude with a 115-volt 60-cps power line.
- Output jack for connection to recorder or headphones. Link unit and chart paper available for use with TYPE 1521-A Graphic Level Recorder.
- Response falls off 12 db/octave far from selected frequency.
- "Trap door" provides quick access to batteries for replacement.
- Narrow bandwidth response is 8% wide 3 db down, allowing easy measurement of signals having wow, yet has 40-db discrimination at one octave from the selected frequency.



Type 1554-A attached to Type 1521-A Graphic Level Recorder.

## SPECIFICATIONS

**Frequency Range:** From 2.5 to 25,000 cps in four ranges. The frequency dial is calibrated from 2.5 to 25 cps; the frequency multiplier switch has four positions: 1, 10, 100, and 1000.

**Accuracy of Frequency Calibration:**  $\pm 2\%$  of frequency dial setting.

**Input Voltage Range:** 100  $\mu$ V to 30 volts for useful indication. Most sensitive range is 1 mv full scale.

**Frequency Response:**

**Narrow:** Maximum response is flat  $\pm 2$  db over the entire tuning range.

**One-Third Octave:** Maximum response is flat  $\pm 4$  db over the entire tuning range. With respect to the ALL-PASS response, the effective bandwidth for noise is one-third octave  $\pm 2$  db.

**All-Pass:** Flat  $\pm 2$  db from 2.5 cps to 25 kc.

**Bandwidth:**

**Narrow:** (See plot.) Response is down 3 db at  $\pm 4\%$  of selected frequency. At one-half and twice selected frequency, response is down more than 40 db.

**One-Third Octave:** (See plot.) Bandwidth is 1.26 to 1

at the 3-db points. At one-half and twice the selected frequency, the response is down more than 30 db.

**Input Impedance:** 100 kilohms, unbalanced. Low input terminal grounded to case.

**Direct Use With Microphone:**

### MICROPHONE TYPE

1560-P12\*

759-P25\*\*

1551-P1L

1551-P1H

### COMPONENT LEVELS MUST EXCEED

50 db re .0002  $\mu$ bar

50 db re .0002  $\mu$ bar

50 db re .0002  $\mu$ bar

65 db re .0002  $\mu$ bar

\* Type 1560-P93 Adaptor required (page 191.)

\*\* Type 1550-P1 Adaptor required.

**Meter:** Three ranges, -10 to +10 db, 0 to 3 volts, and 0 to 10 volts.

**Attenuator:** Adjustable in 10-db steps.

**Output:** Jack on front panel provides approximately 1 volt, open circuit, when meter indicates full scale. Output impedance is 5000 ohms.

**Effects of Humidity:** Operation is adversely affected when relative humidity is high (above 65%, for the lowest range).

**Tubes:** Four CK512AX, two CK526AX.

**Transistors:** One 2N1183, two GR1, seven 2N324, five 2N647.

**Batteries:** Four 1.5-volt (Eveready No. 935 Size C or equivalent) and two 67.5-volt (Eveready No. 467 or equivalent.) Batteries are supplied with instrument. Life of batteries approximately 100 hours.

**Accessories Supplied:** Shielded cable-and-plug assembly for connection to Sound-Level Meter, plug to fit input and output jacks, cable-and-plug assembly for calibration using 115-volt line, pouch for accessories, and chain and splicing link.

**Accessory Available:** TYPE 1554-P1 Carrying Case.

**Dimensions:** Width 10 $\frac{3}{8}$ , height 15 $\frac{3}{8}$ , depth 11 $\frac{1}{2}$  inches (270 by 395 by 295 mm).

**Weight:** 31 $\frac{1}{2}$  pounds (14.3 kg) without accessories or carrying case; 39 $\frac{3}{4}$  pounds (18 kg) with accessories and carrying case.

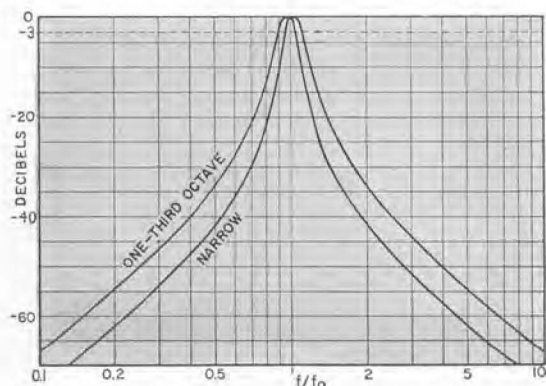

TYPE		CODE WORD	PRICE
1554-A	Sound and Vibration Analyzer	DRAMA	\$1060.00
	Set of Replacement Batteries	DRAMAADBAT	7.80
1554-P1	Carrying Case	CADDY	25.00







## TYPE 1550-A OCTAVE-BAND NOISE ANALYZER

**USES:** The Octave-Band Noise Analyzer is used for the simple and rapid analysis of broad-band noises, where a knowledge of individual frequency components is not required. It is particularly useful for:

Noise measurements on aircraft, vehicles, and machinery;

The analysis of environmental noise, as in offices and factories, where speech-interference level is important;

Studies of environmental noise as related to hearing damage;

Production testing and noise-level acceptance tests;

Calculation of loudness in sones;

Acoustic studies of rooms and materials.

**DESCRIPTION:** The Octave-Band Noise Analyzer is portable, battery-powered, and operates from the output of a sound-level meter, or, when the level is high enough, directly from a microphone. It contains eight bandpass filters, any one of which can be selected by a switch; an attenuator; and an amplifier, which drives both an indicating meter and a monitoring output.

### FEATURES:

➤ Movable reference dial on attenuator to facilitate reading.



- Output for monitoring available at jack.
- Meets ASA standards.
- Operates from output of TYPE 1551-C, -B, or -A or TYPE 759-B Sound-Level Meter or from any other sound-level meter whose output is adequately free of noise and distortion.
- Can be used directly with microphone for high sound levels.
- Amplifier input jack permits amplifier to be used alone.
- Ac power supply can be substituted for batteries for laboratory use.

### SPECIFICATIONS

**Range:** 20 to 10,000 cps in 8 bands:

20 to 75 cps (low pass)	600 to 1200 cps
75 to 150 cps	1200 to 2400 cps
150 to 300 cps	2400 to 4800 cps
300 to 600 cps	4800 to 10,000 (high pass)

In addition, a band with a flat characteristic from 20 cps to 10 kc is available at two switch positions for convenience in calibration against the sound-level meter.

**Input Level:** Between 1 and 10 volts for normal range. Levels below 1 volt reduce the range of reading; those higher than 10 volts overload the filters.

**Input Impedance:** 20,000 ohms. Input is isolated by a resistance pad, so that performance is independent of source if source impedance is constant over audio range or is small compared with 20,000 ohms.

**Output Voltage:** Approximately 1 volt across a 20,000-ohm load.

**Sources:** Sound-level meter supplying analyzer must have low hum, low internal noise, and low distortion. The TYPE 1551-C Sound-Level Meter is recommended.

**Direct Use with Microphone:** The TYPE 1551-P1L and -P1H Condenser Microphone Systems or the TYPE 1560-P12 Dynamic Microphone System can be used if the band levels exceed 70, 85, and 70 db (re .0002  $\mu$ bar),

respectively. A TYPE 1560-P93 Microphone Adaptor Plug is required with the TYPE 1560-P12 Dynamic Microphone System.

**Level Indication:** Level is sum of meter and attenuator readings. Meter is calibrated in db from -6 to +10; the attenuator covers 50 db in 10-db steps.

**Attenuation:** Except for the lowest and highest bands, at least 30-db attenuation is obtained at one-half the lower nominal cutoff frequency and at twice the upper nominal cutoff frequency; at least 50-db attenuation is obtained at one-fourth the lower nominal cutoff frequency and at four times the upper nominal cutoff frequency. The 75-cps low-pass filter has at least 30-db attenuation at 200 cps and 50-db at 400 cps. The 4800-cps high-pass filter has at least 30-db attenuation at 2400 cps and 50 db at 1200 cps.

**Accessories Supplied:** Dial and dial clamp; shielded cable for connecting analyzer to sound-level meter.

**Tube Complement:** Three 1U4 and one 1T4.

**Power Supply:** Battery, Burgess 6TA60, included. For ac operation, TYPE 1261-A Power Supply (page 137) fits battery compartment.

**Dimensions:** Height 12 $\frac{3}{4}$ , width 11 $\frac{3}{4}$ , depth 9 inches (300 by 320 by 240 mm), over-all.

**Net Weight:** 27 lb (12.5 kg) including battery.

TYPE		CODE WORD	PRICE
1550-A	Octave-Band Noise Analyzer	ABEAM	\$575.00
	Replacement Battery	ABEAMADBAT	7.85
1560-P93	Microphone Adaptor Plug	ADAPTORCOP	12.50
1261-A	AC Power Supply	NUTTY	130.00





## TYPE 1553-A VIBRATION METER

**USES:** Vibrations in machines and structures can be measured quickly and easily with this instrument. For the manufacturer of machinery and equipment, the TYPE 1553-A Vibration Meter is extremely useful in research, design, and production testing. Maintenance engineers will find it useful for checking the operating condition of bearings, gear trains, and other mechanisms. Excessive vibrations due to improper adjustment or to structural resonances can be located and measured.

Its excellent low-frequency response permits the study of the operation of belt drives and of the effectiveness of mountings designed to reduce vibrations in adjacent structures.

A frequency analysis of the measured vibration can be made with the TYPE 1554-A Sound and Vibration Analyzer (page 189).

**DESCRIPTION:** The TYPE 1553-A Vibration Meter consists of: an inertia-operated, barium-titanate ceramic pickup, which delivers a voltage proportional to the acceleration of the vibratory motion; an adjustable attenuator; an amplifier; and a direct-reading indicating meter. Integrating networks can be switched to convert the output of the vibration pickup to a voltage proportional to either displacement or velocity.

A differentiating network can be switched in to convert the output of the vibration pickup to a voltage proportional to time rate of change of acceleration, or jerk.

The Vibration Meter indicates directly in peak-to-peak, peak, or average inches, inches per second, inches per second<sup>2</sup>, or inches per second<sup>3</sup>.

Filter jacks on the panel allow the use of external high-pass filters where it is desired to eliminate the frequency components below 30 or 70 cps.

The Vibration Meter is portable, and is mounted in a "flip-tilt" cabinet, which serves as protective cover and case in transit, and as a base on which the instrument can be operated in almost any position from vertical to horizontal. The instrument is powered by readily available batteries, and is equipped with a built-in calibrating circuit.

Accessories include various tips and a metal probe for the pickup to facilitate measurements in normally inaccessible places. Available at additional cost is the TYPE 1560-P35 Permanent-Magnet Clamp, which replaces the probe or tip when measurements are taken under conditions where hand-held operation would not be satisfactory.



## FEATURES:

- Portable and self-contained.
- Easy to operate.
- Direct read-out includes units being measured.
- Low-frequency response down to 2 cycles per second.
- Meter indication independent of load connected to output jack.
- Meter is true peak, peak-to-peak, or average indicator.

- 20-cps cutoff position on function switch increases displacement sensitivity by a factor of 100 over that obtainable with a 2-cps cutoff.
- Measures jerk as well as conventional vibration parameters.
- Can be used to measure acceleration with a suitable pickup over the full 2–20,000-cps range of the amplifier.
- Panel jacks provided for addition of external filters.

## SPECIFICATIONS

### Ranges

Acceleration: 0.3 to 300,000 in./sec<sup>2</sup> peak-to-peak, 0.1 to 100,000 in./sec<sup>2</sup> average.

Velocity: .03 to 30,000 in./sec peak-to-peak, .01 to 10,000 in./sec average.

Displacement: .003 to 300 in. (peak-to-peak), .001 to 300 in. (average) from 2 to 1200 cps; .00003 to 30 in. (peak-to-peak), .00001 to 10 in. (average) from 20 to 1200 cps.

Jerk: 30 to 300,000 in./sec<sup>3</sup> (peak-to-peak), 10 to 300,000 in./sec<sup>3</sup> (average).

**Frequency Range:** With Type 1560-P51 Pickup, 2 to 1200 cps for acceleration, velocity, and displacement, 2 to 20 cps for jerk.

**Accuracy:** ±10% of full scale.

**Input Impedance:** 25 megohms.

**Voltage at Output Jack:** 5 volts rms behind 75 kΩ for full-scale deflection.

**Attenuators:** A 10-step attenuator changes the meter scale range by a factor of 100,000 to 1. Window readout indicates full-scale values and units.

**Calibration:** Internal.

**Allowable Pickup Sensitivity for Direct Reading:** 30 to 150 mv/g.

**Terminals:** A panel jack is provided for plugging in headphones, TYPE 1554-A Sound and Vibration Analyzer, TYPE 1556-A Impact-Noise Analyzer, TYPE 1531-A Stroboscopes® Stroboscope, or oscilloscope.

**Tube and Transistor Complement:** Two CK512AX, five 6X418, one 2N520A, one 2N527, and one 2N377A.

**Batteries:** 3 Size D cells and one 67-volt battery (Burgess TYPE XX45 or equivalent) supplied. Typical battery life, 7 days at 8 hours per day.

**Accessory Supplied:** TYPE 1560-P51 Vibration Pickup.  
**Case:** Flip-tilt aluminum case; pickup and probe store inside.

**Dimensions:** Width 8, height 9¼, depth 7½ inches (205 by 235 by 195 mm), over-all (case closed).

**Net Weight:** 10½ lb (4.8 kg).

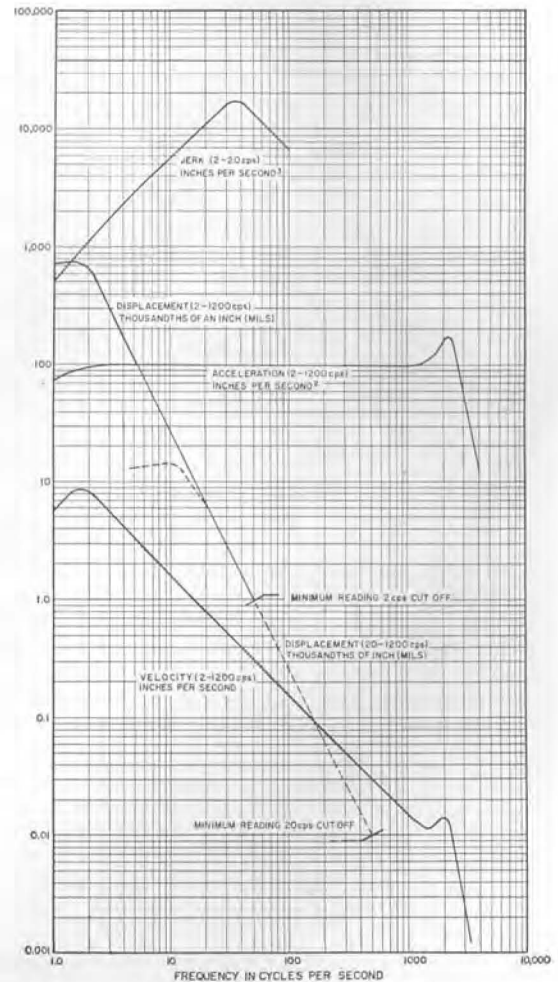

Readings of the Vibration Meter as a function of frequency for a constant acceleration of 100 inches per second<sup>2</sup>.

TYPE		CODE WORD	PRICE
1553-A†	Vibration Meter.....	WAGER	\$675.00
1560-P51	Replacement Pickup*.....	VIBRO	80.00
	Set of Replacement Batteries.....	WAGERBAT	4.10
1560-P35	Permanent-Magnet Clamp.....	MAGNO	6.50

\* Give instrument and serial number when ordering. † PATENT NOTICE. See Note 22, page viii.





**TYPE 1557-A VIBRATION CALIBRATOR**



**USES:** The Vibration Calibrator is a convenient device for calibrating vibration pickups, accelerometers, vibration meters, and other vibration-measuring systems that use small, piezoelectric accelerometers as the sensing elements. The calibrator provides a single-frequency (100 cps), single-level (1 g) check on the TYPE 1560-P51 Vibration Pickup (part of the TYPE 1560-P11 Vibration Pickup System), the TYPE 1553-A Vibration Meter, or any pickup whose total mass is 300 grams or less. It can provide on-the-spot calibration of vibration-measuring systems immediately before and after important measurements and can also be used to compare transducers or to

calibrate working transducers against a laboratory standard transducer.

**DESCRIPTION:** The Vibration Calibrator is a small, battery-operated unit consisting of a transistorized electromechanical oscillator and a cylindrical shaker. The acceleration output of the Calibrator appears at two pillbox-shaped, 50-gram disks mounted on an internal cylinder that projects through the sides of the instrument.

Operation of the calibrator is simple. A pickup of known mass is attached to the shaker, either in place of one of the removable 50-gram disks or to one of the disks by double-faced, pressure-sensitive tape. The user adjusts the LEVEL control until the panel meter, calibrated in grams, indicates the mass of the pickup. The pickup will then be automatically subjected to an acceleration of 1 g at 100 cps. The only other control on the instrument is a combination on-off switch and battery checker.

Life tests on the calibrator indicate that it will operate continuously for over 1000 hours. Since normal operation will usually be below the maximum and will not be continuous, the calibrator should give trouble-free service for many years.

**FEATURES:**

- Completely portable, with long-life mercury batteries.
- Accommodates most of the accelerometers and vibration pickups in use today.
- Weighs less than four pounds, with leather carrying case provided.

**SPECIFICATIONS**

**Output**

- Acceleration:** 1 g rms  $\pm 10\%$ .
- Velocity:** 0.614 in./sec rms.
- Displacement:** .000978 in. rms (.00277 in. peak to peak).
- Frequency:** 100 cps  $\pm 1\%$  for 50-gram load; 100 cps  $+0, -2\%$  for 300-gram load.
- Batteries:** Four RM-4 (or equivalent) mercury cells. Battery life is 100 hours of continuous operation.
- Accessory Supplied:** Leather carrying case.
- Dimensions:** Width 4, height 8, depth 4 inches (105 by 205 by 105 mm).
- Net Weight:** 3 1/4 lb (1.5 kg), including case.

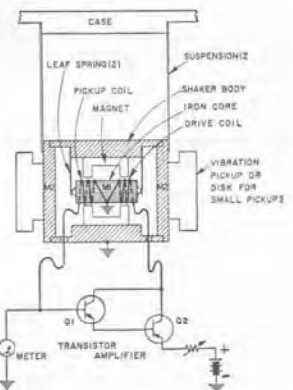

Functional diagram of the calibrator.

TYPE	CODE WORD	PRICE
1557-A   Vibration Calibrator .....	VIVID	\$225.00

# STROBOSCOPES



The Stroboscope is basically a light source that can be flashed on and off at high speeds to produce the optical effect of slowing down or stopping motion. For instance, an electric fan revolving at 1800 rpm appears to be standing still when observed under light that flashes uniformly 1800 times a minute. If the light flashes 1799 times a minute, the fan appears to rotate at 1 rpm; at 1801 flashes a minute, the fan appears to rotate backward at 1 rpm. Because the human eye retains images for an appreciable fraction of a second, no flicker is seen except at very low speeds. The apparent slow motion is an exact replica of the actual higher-speed motion, so that the motion of a high-speed machine can be analyzed while the machine is in normal operation.

If the flashing rate of the stroboscope is adjustable, and if the control is calibrated in flashes per minute, the stroboscope becomes a highly precise tachometer. The flashing-rate control is simply adjusted to the point where the moving device appears stationary, and the speed in revolutions (flashes) per minute is read from the calibrated control.

General Radio stroboscopes are electronic flash devices, which produce flash durations as brief as a millionth of a second. Such short flashes effectively arrest very rapid motion, making possible high-speed photographs such as the well known "milk-drop shot" shown on this page.

The first General Radio stroboscope was made more than 25 years ago, and since then a continuous development program in this field has produced the finest stroboscopic equipment available anywhere. The registered trade name for the GR stroboscope is Strobotac, and the newest Strobotac stroboscope, the TYPE 1531-A, represents a major advance in this field.

The Strobotac® Electronic Stroboscope

is a compact instrument that operates from a 115-volt ac line. Its wide flashing range permits measurement of speeds up to a quarter of a million rpm, with 1% accuracy. The Strobotac is also useful for "slow-motion" observations and, because of its bright short-duration flash, for high-speed photography.



Under a stroboscope's light, the fast action of textile machinery is frozen for inspection or for speed measurements.

For applications requiring a brighter light than even the Strobotac can supply, the TYPE 1532-D Strobolume can be added. The Strobolume can be flashed either by an external contactor or by the Strobotac.

The TYPE 1535-B Contactor is a device that can be attached to a rotating shaft to trigger a stroboscope once for each revolution of the shaft. In this way the stroboscope can be synchronized with a shaft whose speed may be constantly varying. A phasing control permits flashing of the light at any point in the 360° rotation of the shaft.

High-speed photographs such as these, of a milk drop hitting a metal plate, are made possible by the stroboscope's brief flash.



# STOBOSCOPES

## STROBOTAC



### TYPE 1531-A STROBOTAC®

#### ELECTRONIC STROBOSCOPE

**USES:** The Strobotac® Electronic Stroboscope is a small, portable flashing-light source used to measure the speed of fast-moving devices, or to produce the optical effect of stopping or slowing down high-speed motion for observation.

- Typical applications of the Strobotac include
- observation and speed measurement of: gears, fans, cams, linkages, shuttles, spindles, and other machine elements;
  - observation, either visual or photographic, of equipment under vibration test, droplet size and spray pattern of diesel fuel nozzles, structural vibration (such as helicopter blade flutter) in wind-tunnel tests;
  - high-speed photography of repetitive or non-repetitive motion (see photos on page 195);
  - measurements and observations of any repetitive motion that can be seen, even if physically inaccessible.

**DESCRIPTION:** The Strobotac® Electronic Stroboscope includes a Strobotron lamp and reflector assembly, an electronic pulse generator that controls the flashing rate, and a power supply that operates from an ac line.

The flashing-rate range of 110 to 25,000 flashes per minute is divided into three direct-reading ranges. Attached to the range switch is a mask, through which only the scale in use is visible. The RPM control is concentric with this mask, and its large diameter permits precise control of the flashing rate.

A built-in calibration system permits use of the power-line frequency to check accuracy of the flashing rate. Adjustment, if necessary, is made at the front panel.

An external contactor, such as the TYPE 1535-B, can be used to trigger the Strobotac through a panel phone jack. An output jack, also on the panel, supplies a negative pulse of



600 to 800 volts to drive auxiliary equipment, such as the Strobolume (page 197).

The Strobotron tube is mounted in a reflector housing that both pivots in a plane perpendicular to the panel and swivels 360 degrees on its own axis. The instrument can be operated while suspended by a neck strap, held in the hand, or set on a bench. Its "flip-tilt" cabinet serves as rugged carrying case for instrument and instruction manual, protective cover, and base for the instrument in operation.

#### FEATURES:

- High-intensity flash, up to 7 million beam-candlepower (peak) for a single flash.
- Wide range of flashing rates, up to 25,000 flashes per minute (permitting speed measurements up to 250,000 rpm).
- High accuracy (1%) for speed measurements.
- Small, easily held, flip-tilt case.
- Short flash gives sharp images for photography.
- Easy to set, easy to read dials.

The versatile "flip-tilt" case offers a variety of operating positions, is closed and ready to travel in seconds.





### SPECIFICATIONS

**Flashing-Rate Range:** 110 to 25,000 flashes per minute in three direct-reading ranges: 110 to 690, 670 to 4170, and 4000 to 25,000. Speeds up to 250,000 rpm can be measured.

**Accuracy:** 1% of dial reading after calibration on middle range.

**Calibration:** Two panel adjustments permit calibration against power-line frequency.

**Flash Duration:** Approximately 0.8, 1.2, and 3 sec for high-, medium-, and low-speed ranges, respectively, measured at 1/3 peak intensity.

**Peak Light Intensity:** 0.21, 1.2, and 4.2 million beam candlepower ( $2.1 \times 10^6$ ,  $1.2 \times 10^6$ , and  $4.2 \times 10^6$  lux measured at 1 meter distance at the center of the beam) minimum on high-, medium-, and low-speed ranges, respectively; 7 million beam candlepower ( $7 \times 10^6$  lux measured at 1 meter distance at the center of the beam) for single flash.

**Reflector Beam Angle:** 10 degrees at half-intensity points.

**Output Trigger:** 600- to 800-volt negative pulse available at panel jack.

**External Triggering:** Strobotac can be triggered with a mechanical contactor or 6-volt peak-to-peak signal (2-volt rms sine-wave signal down to 5 cps).

**Power Supply:** 105-125 (or 210-250) volts, 50-60 or 400 cps. Maximum power input is 35 watts.

**Tube Complement:** One 5965, one 5727, one 1531-P Strobotron.

**Accessories Supplied:** Adjustable neck strap, plug to fit input and output jacks, spare fuses.

**Mounting:** Aluminum case with attached cover and carrying handle, gray-wrinkle finish.

**Dimensions:**  $10\frac{5}{8}$  by  $6\frac{5}{8}$  by  $6\frac{1}{4}$  inches (270 by 170 by 160 mm), over-all, including handle.

**Net Weight:**  $7\frac{1}{8}$  lb (3.2 kg).  
This instrument is listed by the CSA Testing Laboratories as approved.

TYPE		CODE WORD	PRICE
1531-A	Strobotac® Electronic Stroboscope	BELAY	\$260.00
1531-P1	Replacement Strobotron Tube	DRUID	15.00

PATENT NOTICE. See Notes 6 and 22, page viii

## TYPE 1532-D STROBOLUME

### HIGH-INTENSITY STROBOSCOPE



**USES:** The Strobolume produces a brilliant white light flash useful for studying motions of machines operating at relatively low speeds. At low flashing rates the Strobolume's light is of a higher intensity than that of the Strobotac® Electronic Stroboscope.

The Strobolume can be triggered by a spring-loaded toggle switch on the control panel, by an external contactor such as the TYPE 1535-B, or by a Strobotac. It is a useful light source for single- and multiple-flash

photography, when the motion of the subject is often too fast to be stopped by conventional "speedlights."

**DESCRIPTION:** The Strobolume consists of a high-voltage transformer and rectifiers, a capacitor that is charged to about 2500 volts from the rectifiers, and a lamp through which the capacitor is discharged to produce the flash. The discharge is initiated by a special Strobotron tripped by an external impulse. Two ranges of intensity and flashing rate are provided.

#### FEATURES:

- High-intensity short flash.
- Operates from Strobotac or contactor.
- Wide beam angle.
- Compact, light-weight assembly.
- Lamp assembly is removable, with 14-foot extension cable.
- Lamp housing has socket with standard tripod thread.
- Long-life sealed-beam lamp.

### SPECIFICATIONS

#### Flashing Speed Range

**High Intensity:** up to 60 flashes per minute continuous, up to 1200 per minute intermittent.

**Low Intensity:** up to 3000 flashes per minute continuous.

**Peak Light Intensity:** 10 million beam candlepower ( $10^7$  lux measured at 1 meter distance at the center of the

beam) from single flash to 60 flashes per minute, 0.14 million beam candlepower ( $1.4 \times 10^6$  lux at 1 meter distance at the center of the beam) at 3000 flashes per minute.

**Flash Duration:** Approximately 30 microseconds at high intensity, 10 microseconds at low intensity.

**Beam Width:** 45 degrees at half-intensity points.



# STROBOSCOPES

## CONTACTOR



**Guide Number:** The guide number (distance in feet times aperture) for high intensity is approximately 25 with film speed of 100 (ASA).

**Flashing Control:** TYPE 1535-B Contactor, or TYPE 1531-A Strobotac with TYPE 1532-P3 Trigger Cable.

**Tube Complement:** One TYPE 0A5 Strobotron, one TYPE 1532-P1 Flash Lamp (GE TYPE FT-220).

**Accessories Supplied:** TYPE CAP-22 Three-Wire Power Cable, TYPE 1532-305 Adaptor Assembly (for three-wire to two-wire power service), TYPE 1532-2060 Contactor Cable Assembly, and plug for connection to contactor.

**Other Accessories Required:** None, if lamp is to be flashed manually by push button. For stroboscopic work, a TYPE 1535-B Contactor, or a TYPE 1531-A

Strobotac with TYPE 1532-P3 Trigger Cable is needed. For use with older TYPE 631-BL Strobotac, a TYPE 1532-P2 Transformer Cable is required.

**Mounting:** Metal case. Lamp assembly is removable. Storage space for lamp cable is provided in case. Lamp housing has  $\frac{1}{4}$ -20 threaded socket for tripod.

**Power Input:** 105 to 125 volts, 50 to 60 cps. 230-volt model, TYPE 1532-DQ18, is available. Power consumption on high intensity is 105 watts at 60 flashes per minute, 500 watts at 1200 flashes per minute; at low intensity, 120 watts at 3000 flashes per minute.

**Dimensions:** Width  $7\frac{1}{2}$ , height  $11\frac{1}{2}$ , depth 13 inches (195 by 295 by 330 mm), over-all; lamp unit, 6 inches diameter by  $5\frac{3}{4}$  inches (155 by 150 mm).

**Net Weight:**  $18\frac{1}{2}$  lb (8.5 kg); lamp unit, 2 lb (1 kg).

TYPE		CODE WORD	PRICE
1532-D	Strobolume, 105-125 volts, 50-60 cps. . . . .	TITLE	\$315.00
1532-DQ18	Strobolume, 210-250 volts, 50-60 cps. . . . .	TITLEREPHEL	340.00
1532-P1	Replacement Lamp . . . . .	TOWEL	25.00
1532-P2	Transformer Cable . . . . .	TULIP	15.00
1532-P3	Trigger Cable . . . . .	TALLY	15.00

PATENT NOTICE. See Note 6, page viii.



## TYPE 1535-B CONTACTOR

The phasing system includes a scale graduated in five-degree intervals and two phasing controls, which permit 360-degree adjustment of the contact position with respect to the rotating shaft.

The mechanical coupling system consists of an 18-inch flexible shaft, whose free end terminates in a powerful, multipole Alnico magnet. A spring-loaded centering device on the magnet ensures positive drive from a centered steel or iron shaft without need for drilling and tapping the shaft.

The entire assembly is mounted on a sturdy four-foot rod secured in a cast-iron base. The contactor can be positioned at any point on this rod and is locked in position by a thumbscrew.

### FEATURES:

- Can be easily attached to or removed from machine in motion.
- Ball bearings are used on rotating parts.
- Flexible drive coupling shaft can be bent through 90° angle for work in crowded locations.
- Auxiliary coupling devices are furnished for permanent coupling to shaft, or for use with nonmagnetic shaft.
- Contactor can be removed from stand and mounted permanently on machine.
- When used with Strobotac or Strobolume stroboscopes, permits observation of machines with erratic speed.

**USES:** The TYPE 1535-B Contactor is a control and coupling device that permits synchronization of a stroboscope with a rotating shaft, so that motion can be observed as a function of shaft angle. With the aid of the Contactor, the stroboscope can be used in the observation of machines with varying speed.

**DESCRIPTION:** The elements of the Contactor are the electrical contacts, the phasing system, and the mechanical coupling system.

The electrical contact system consists of a rotating cam and a low-inertia breaker arm. One contact is made for each revolution of the drive shaft.

## SPECIFICATIONS

**Speed Range:** 0 to 1000 rpm.

**Contacts per Revolution:** One.

**Range of Phase Adjustment:** 360°.

**Range of Height Adjustment:** 6 inches to 4 feet.

**Diameter of Base:** 18 inches.

**Accessories Supplied:** Hex wrench, auxiliary coupling devices for connection to shaft in which hole has been

drilled, and TYPE 1535-P5 Adaptor for connecting to TYPE 1531-A or TYPE 1532-D.

**Other Accessories Required:** For use with TYPE 1531-A Strobotac, a TYPE 1535-P5 Adaptor is supplied. Older, TYPE 631-BL Strobotac requires TYPE 1535-P1 Adaptor Cable.

**Net Weight:**  $19\frac{3}{4}$  lb (9 kg).

TYPE		CODE WORD	PRICE
1535-B	Contactor . . . . .	CROOK	\$170.00
1535-P1	Adaptor Cable . . . . .	CROOKCABLE	6.00
1535-P5	Adaptor . . . . .	TAPER	5.00





# VARIAC<sup>®</sup> AUTOTRANSFORMERS



General Radio's Variac<sup>®</sup>\* autotransformers give smooth, continuous, manual control of ac voltage from zero to 17% above the input line voltage. They are available in single units and in combinations, with ratings from 300 va to 54 kva. Variac autotransformers are designed for maximum efficiency, continuous service, and long life with minimum maintenance.

**USES:** A few of the applications of the Variac autotransformer in the shop and in the laboratory are:

- Control of ac voltage in testing and development work.
- Overvoltage and undervoltage tests.
- Voltage control of aging racks for lamps, vacuum tubes, dry-disk rectifiers, etc.
- Voltage control in power supplies.
- Voltage control for meter calibration.
- Phase-angle control in the calibration of wattmeters and power-factor meters.
- Motor speed control.
- Control of electric heaters and ovens in laboratory, pilot plant, and production line.
- Lighting control in theaters, auditoriums, photographic studios, and darkrooms.

Although built for 120- or 240-volt circuits, Variac autotransformers can be used on circuits of higher or lower voltage in conjunction with fixed-ratio auxiliary transformers. Ganged units are available for parallel, series, and polyphase connections (page 205).

**DESCRIPTION:** The Variac autotransformer consists of a single-layer winding on a toroidal silicon-steel core. As the control knob is rotated, a carbon brush traverses the winding, tapping off a portion of the total voltage across

\* VARIAC is the registered trade name of the General Radio brand of adjustable autotransformers and associated control equipment in which these adjustable autotransformers are used.

† Developed in the General Radio Laboratories.  
PATENT NOTICE. See Note 7, page viii.

the winding. The brush is in continuous contact with the winding, and the voltage between turns is always less than 1 volt, even in the largest model; in the smallest model it is only about 0.3 volt.

The discrete voltage increments obtained as the knob is rotated are always less than the voltage between turns. Since the brush spans more than one turn, the change in voltage is practically continuous. The brush is so designed that excessive heating cannot occur in the turns that it spans.

**DURATRAK†:** All Variac autotransformers have *Duratrak* coating process. The brush-track surface is coated with a uniform silver alloy to prevent injurious high-temperature oxidation and resultant brush-track deterioration. The track shows no significant wear after one million cycles of brush operation (zero to maximum, and return). The *Duratrak* process makes the Variac autotransformer as durable as a fixed-ratio autotransformer. *Duratrak* means long life, high overload capacity, and minimum maintenance. With this treatment the Variac autotransformer can withstand a momentary overload of 1000 percent without damage.

## FEATURES:

- High efficiency.
- Smooth control.
- Good voltage regulation.
- Output voltage may be greater than line voltage.
- Negligible waveform distortion.
- Linear voltage variation with dial rotation.
- Adaptability to motor drive.

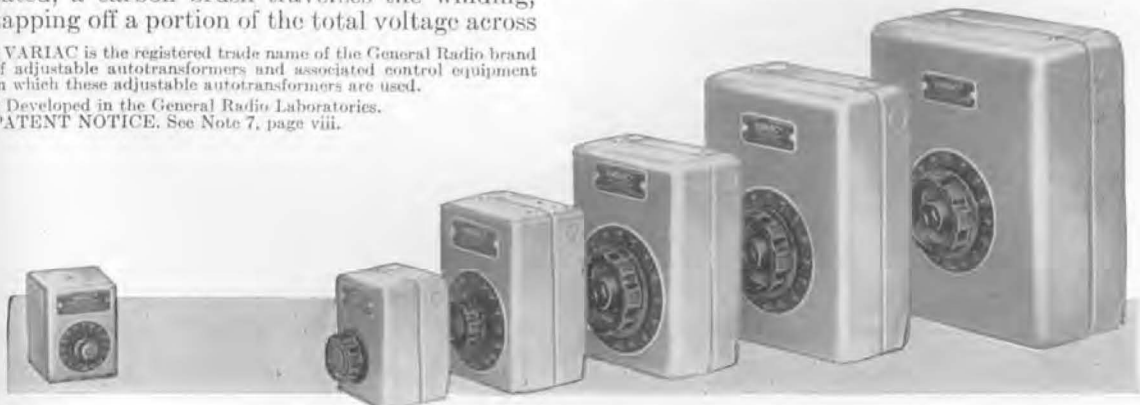



VARIAC® AUTOTRANSFORMER  
TYPE-NUMBER TERMINOLOGY

Type numbers for Variac® autotransformers, in their various combinations, consist of letters and numerals that indicate exactly what elements are included in each assembly. The following examples will serve to illustrate the system:

TYPE W10MT3 indicates a 120-volt, single-unit, portable, TYPE W10 Variac autotrans-

former with a three-wire line cord.

TYPE W50G6BBM indicates a six-gang, TYPE W50 model, with ball bearings and case.

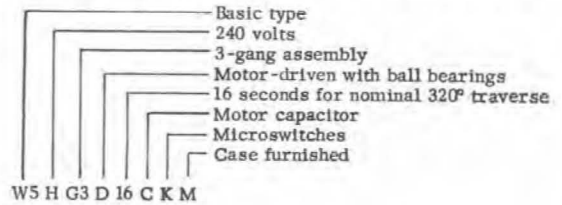

GENERAL SPECIFICATIONS

**Dial:** Dial plates are reversible — 0 to 120 volts on one side, 0 to 140 on the other. H types have similar scales — 0 to 240 and 0 to 280. Dials for ganged assemblies are marked 0 to 10.

**Frequency:** W models are designed for 50- to 60-cycle service, M models for 350- to 1200-cycle service. Most W models, however, can be operated at rated current and voltage at line frequencies of 50 to 400 cps. Models designed for 240-volt, 50- to 60-cycle service can be used on a 25-cycle supply at full current rating, but one-half their voltage and kva ratings.

**Protective Devices:** TYPES MT and MT3 have built-in circuit breakers with manual resets. TYPES W5L, W20H, W30, W30H, W50, and W50H have built-in fuse-type protectors (Figure 1). However, these are not a substitute for standard fusing practices.

**Overload Ratings:** Rated current may be safely exceeded with short-time overloads, as indicated by the curves below. The shaded area (Figure 1) shows the limits for the models with built-in, fuse-type protectors.

**Temperature Rise:** Ratings are based on a temperature rise of not more than 50 C above room temperature. When the ambient temperature exceeds 50 C, the kva ratings must be decreased as shown by the chart below (Figure 2).

**Rated Current** is that current which may be drawn at any dial position.

**Maximum Current** is that current which may be drawn at maximum output voltage when the line-voltage connection (see below) is used.

**Output Voltage** is the range of voltage available at the output terminals with rated voltage applied to the input terminals.

**Line-Voltage Connection** refers to that connection which gives an output voltage range of zero to line voltage.

**Overvoltage Connection** refers to that connection which gives an output voltage range of zero to 17% above line voltage.

**Kva Rating** is the maximum current multiplied by the normal input line voltage. At any lower setting, a Variac autotransformer can handle a constant-impedance load that draws a current no greater than the maximum current with rated input voltage.

**No-Load Loss** is measured in watts at 60 cps with rated input voltage. Losses are guaranteed not to exceed the values given in the tables of ratings on the following pages.

**Driving Torque** is the torque required to turn the shaft.

**Terminals:** The following types have combination soldering- and screw-type terminals: W2, W5, W5L, W10, W10H, W20, W20H, W30H, and W50H. The TYPES W30 and W50 models have clamp-type terminals to accommodate the higher available current.

**Dimensions:** Essential dimensions are given in the diagrams for each type of Variac autotransformer. Detailed dimension drawings and drilling templates will be furnished on request.

**Weight:** See tables of ratings on the following pages.

**Panel Thickness** is the maximum thickness of the panel on which the unit can be mounted, using the length of shaft that is normally supplied.

Figure 1. For use when high initial surge current may be expected (motor starting, incandescent lamp load, etc.) and for short-time overloads, the rated current may be exceeded on a time-current basis when line-voltage connection is used, as shown in this figure.

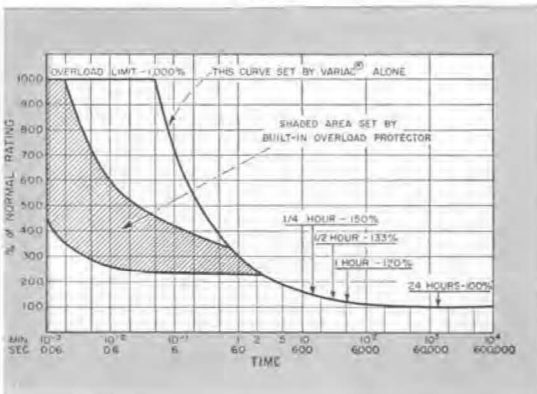
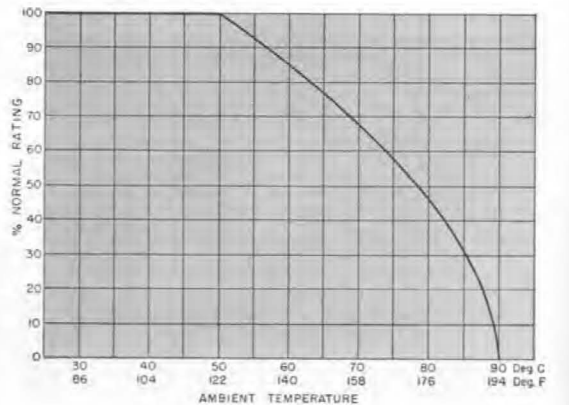

Figure 2. For ambient temperatures above 50 C, the unit should be derated according to this curve.





Cased models for wall mounting have conduit knock-outs.



Uncased models for panel mounting.

Portable models with convenient handles have overload protector and are available with 2- or 3-wire cords.

### THE W SERIES VARIAC® AUTOTRANSFORMER

The present W series, with *Duratrak*, is the result of a continuous development program that started more than 25 years ago, when General Radio introduced the first commercial variable autotransformer. The introduction of the W series was a major step forward in this program. Most W models are listed under the Re-examination Service of the Underwriters' Laboratory and have the approval of the Canadian Standards Association.

All W series Variac autotransformers are *Duratrak* treated. Other special features include counterbalanced rotating parts, a wiring diagram on the terminal board, and military ruggedization. The basic open units have square mounting bases for convenient installation. Cased models are totally enclosed for protection from dust, but covers are easily removed for access to the interior. Cased models for wall mounting contain conduit

knockouts for both individual units and ganged assemblies. A portable model, with a built-in circuit breaker and carrying handle, may be used in either a horizontal or a vertical position. This model is available with either the new standardized, three-wire, grounding cord set or with the more usual two-wire arrangement.

The flexibility of the W series models permits the manufacture of units incorporating many special modifications, such as the addition of ball bearings, motor drive, continuous 360-degree rotation, or two separate brush tracks.

Series W models are interchangeable with the comparable-size, older, series V models; corresponding mounting holes are provided.

Series M models, (page 210) for 350- to 1200-cycle service, are similar in design to series W models.



Terminal plates on both 120- and 240-volt models are stamped with wiring diagram and ratings.

Overload protector, an important feature on portable models, is quickly reset from front panel.

Shaft can be easily adjusted or replaced without disturbing other parts of the assembly.

Cover of cased model is easily removable for access to terminals, mounting holes, and brush.





# RATINGS

for

## SINGLE-UNIT W-SERIES VARIAC® AUTOTRANSFORMERS

with DURATRAK COATING PROCESS

This table lists commonly used single units and does not include all possible applications.

INPUT VOLTAGE	OUTPUT					TYPE	60-CYCLE NO-LOAD LOSS WATTS	DRIVING TORQUE OUNCE-INCHES	NET WEIGHT POUNDS	APPROXIMATE SHIPPING WEIGHT—POUNDS	CODE WORD	PRICE	REPLACEMENT BRUSH	ADD FOR BALL BEARINGS (NOTE E)
	Line-Voltage Connection				Overvoltage Connection									
	KVA LOAD RATING (SEE NOTE A)	VOLTAGE RANGE	RATED CURRENT AMPERES	MAXIMUM CURRENT AMPERES (SEE NOTE A)	VOLTAGE RANGE									
120	See Note C				0-140	2.0	W2MT† (Portable 2-wire)	3.5	5-10	4¼	10	BAGIC	\$26.00	Type VB-1 75¢ \$5.00
120	See Note C				0-140	2.0	W2MT3† (Portable 3-wire)	3.5	5-10	4¼	10	BAGOM	28.00	
120	0.31	0-120	2.0	2.6	0-140	2.0	W2M† (With case)	3.5	5-10	4¼	9	BAGER	21.00	
120	0.37	0-120	2.4	3.1	0-140	2.4	W2† (Uncased)	3.5	5-10	3½	6	BAGAL	15.00	
120	See Note C				0-140	5	W5MT† (Portable 2-wire)	9	10-20	8¼	15	COTIC	30.00	Type VB-2 75¢ \$6.00
120	See Note C				0-140	5	W5MT3† (Portable 3-wire)	9	10-20	8¼	15	COTOM	32.50	
120	0.78	0-120	5.0	6.5	0-140	5	W5M† (With case)	9	10-20	7¼	13	COTER	24.00	
120	0.94	0-120	6.0	7.8	0-140	6	W5† (Uncased)	9	10-20	6½	12	COTAL	18.00	
120	1.1	0-120	7.1	9.2	See Note D		W5LM (With case)	12	10-20	7¼	13	COTAT	23.50	
120	1.1	0-120	7.1	9.2	See Note D		W5LMT3 (Portable 3-wire)	12	10-20	8½	15	COTOS	34.50	
120	1.32	0-120	8.5	11	See Note D		W5L* (Uncased)	12	10-20	6¾	12	COTUG	17.50	
120	1.56	0-120	10	13	0-140	10	W10† (Uncased)	17	15-30	12½	18	DOGAL	31.00	Type VB-10 \$1.25 \$7.00
120	1.56	0-120	10	13	0-140	10	W10M† (With case)	17	15-30	15½	21	DOGER	44.00	
120	See Note C				0-140	10	W10MT† (Portable 2-wire)	17	15-30	16	24	DOGIC	51.00	
120	See Note C				0-140	10	W10MT3† (Portable 3-wire)	17	15-30	16	24	DOGOM	53.50	
120	3.12	0-120	20	26	0-140	20	W20† (Uncased)	27	45-90	21½	27	FEDAL	48.00	Type VB-8 \$2.50 \$8.00
120	3.12	0-120	20	26	0-140	20	W20M† (With case)	27	45-90	24½	27	FEDER	61.00	
120	See Note C				0-140	20	W20MT3† (Portable 3-wire)	27	45-90	28	38	FEDOM	90.00	
120	3.84	0-120	28	32	0-140	28	W30M (With case)	35	50-100	37	46	KALER	97.00	Type VB-13 \$4.00 \$11.00
120	4.32	0-120	30	36	0-140	30	W30 (Uncased)	35	50-100	30	36	KALAL	75.00	
120	5.40	0-120	40	45	0-140	40	W50M† (With case)	50	150-300	57	74	GATER	145.00	Type VB-6 \$5.50 \$15.00
120	6.00	0-120	50	50	0-140	50	W50† (Uncased)	50	150-300	50	65	GATAL	120.00	

See footnotes on following page.





# RATINGS

for

## SINGLE-UNIT W-SERIES VARIAC® AUTOTRANSFORMERS

with DURATRAK COATING PROCESS

This table lists commonly used single units and does not include all possible applications.

INPUT VOLTAGE	OUTPUT				Overvoltage Connection		TYPE	60-CYCLE NO-LOAD LOSS WATTS	DRIVING TORQUE OUNCE-INCHES	NET WEIGHT POUNDS	APPROXIMATE SHIPPING WEIGHT—POUNDS	CODE WORD	PRICE	REPLACEMENT BRUSH	ADD. FOR BALL BEARINGS (NOTE E)
	Line-Voltage Connection				VOLTAGE RANGE	RATED CURRENT AMPERES (SEE NOTE B)									
	KVA LOAD RATING (SEE NOTE A)	VOLTAGE RANGE	RATED CURRENT AMPERES	MAXIMUM CURRENT AMPERES (SEE NOTE A)											
240	See Note C				0-280	2	W5HMT (Portable 2-wire)	9	10-20	8¼	15	JOBIC	\$33.50	Type VB-1 75¢	\$6.00
240 120	0.62	0-240	2.0	2.6	0-280 0-280	2 1	W5H† (Uncased)	9	10-20	6½	10	JOBAL	21.50		
240 120	0.62	0-240	2.0	2.6	0-280 0-280	2 1	W5HM† (Cased)	9	10-20	7¼	13	JOBER	27.50		
240 120	1.25	0-240	4	5.2	0-280 0-280	4 2	W10H† (Uncased)	17	15-30	12	18	LUTAL	33.00	Type VBT-11 \$1.25	\$7.00
240 120	1.25	0-240	4	5.2	0-280 0-280	4 2	W10HM† (With Case)	17	15-30	14½	21	LUTER	46.00		
240	See Note C				0-280	4	W10HMT (Portable 2-wire)	17	15-30	15½	24	LUTIC	53.00		
240	See Note C				0-280	4	W10HMT3† (Portable 3-wire)	17	15-30	15½	24	LUTOM	55.50		
240 120	2.50	0-240	8	10.4	0-280 0-280	8 4	W20H† (Uncased)	27	45-90	20½	27	MEPAL	50.00	Type VBT-12 \$2.50	\$8.00
240 120	2.50	0-240	8	10.4	0-280 0-280	8 4	W20HM† (With case)	27	45-90	23½	31	MEPER	63.00		
240	See Note C				0-280	8	W20HMT3† (Portable 3-wire)	27	45-90	27	35	MEPOM	92.00		
240 120	3.74	0-240	12	15.6	0-280 0-280	12 6	W30H (Uncased)	35	50-100	29	36	ZABAL	75.00	Type VBT-14 \$4.00	\$11.00
240 120	3.74	0-240	12	15.6	0-280 0-280	12 6	W30HM (With case)	35	50-100	36	46	ZABER	97.00		
240 120	7.45	0-240	20	31	0-280 0-280	20 10	W50HM† (With case)	50	150-300	60	76	NITER	145.00	Type VBT-7 \$5.50	\$15.00
240 120	7.80	0-240	25	32.5	0-280 0-280	25 12.5	W50H† (Uncased)	50	150-300	53	67	NITAL	120.00		

**NOTES**

- A. Maximum current can be drawn at maximum voltage for the line-voltage connection only. Kva as listed = normal input line voltage times maximum current.
- B. Rated current should not be exceeded for the overvoltage connection. Output kva for overvoltage connection = output voltage times rated current.
- C. Type MT and MT3 models have overvoltage connection and corresponding dial scales but can be supplied on special order with line-voltage connections and dial scales.
- D. For 60-cycle use only; no overvoltage connection provided.
- E. When ordering a unit with ball bearings, add the suffix "-BB" to the type number and the suffix BALLY to the code word.

\*Listed under the Re-examination Service of the Underwriters' Laboratories.  
†Approved by the Canadian Standards Association.





AUTOTRANSFORMERS

SINGLE UNIT W-SERIES

VARIAC® AUTOTRANSFORMER DIMENSIONS†

Type W5MT, Portable Model with 2-wire Cord.

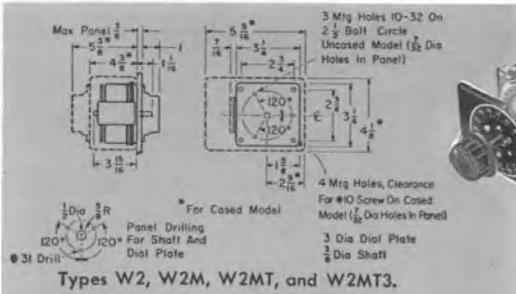

Type W2, Uncased Basic Model.



Type W10, Cased Model.

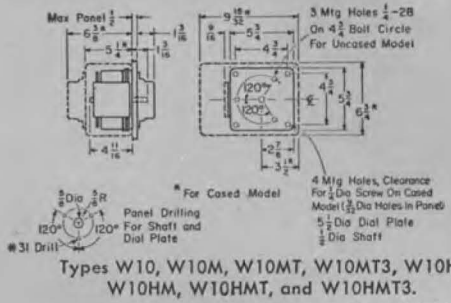
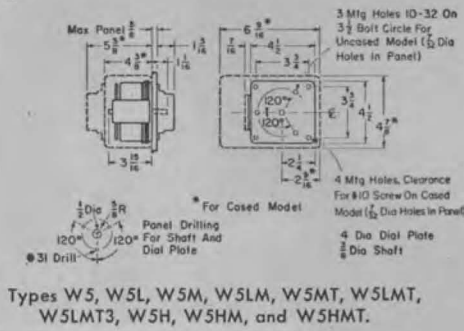

Type W50M, Cased Model

Type W30, Uncased Basic Model.

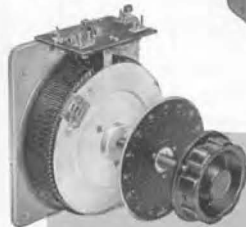

Type W20M, Cased Model.

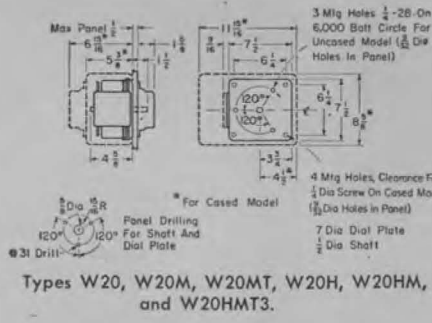

Types W30, W30M, W30H, and W30HM.

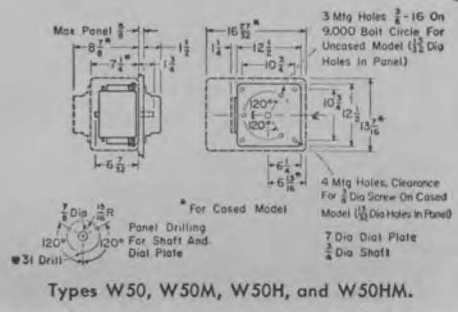
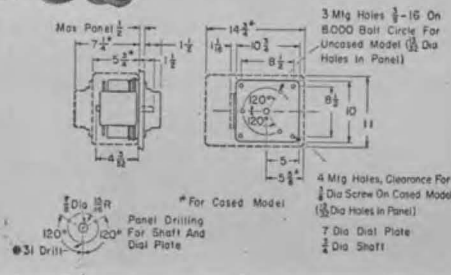

† Given in inches; to convert to mm, multiply by 25.4.



# GANGED VARIAC® AUTOTRANSFORMER ASSEMBLIES

for parallel, series, and three-phase operation

The usefulness of the Variac autotransformer is greatly extended by means of multigang assemblies (two, three, four or six). They can be used to control

several circuits from a single knob and to control three-phase circuits, either wye- or delta-connected.

## PARALLEL COMBINATIONS

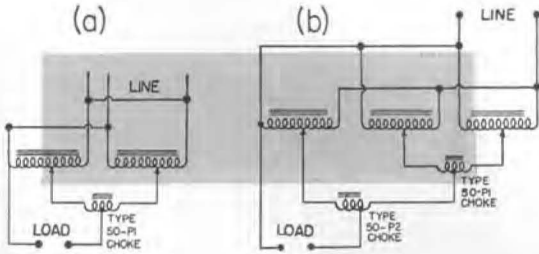

The larger models (TYPES W20, W30, and W50) can be operated in parallel if a TYPE 50-P1 Choke is used to limit circulating current, as shown in circuit (a) at the left. Load rating of two identical units in parallel is twice that of a single unit. Parallel operation is not usually recommended for smaller models, since the use of the next larger size is more economical. Where a load rating in excess of two TYPE W50 units is needed, a third unit can be added by use of a TYPE 50-P2 Choke, as shown in circuit (b). Four-gang and six-gang units can also be paralleled. See page 206 for prices of chokes, and number required.

## THREE-PHASE COMBINATIONS

**Open-Delta Connection:** With this connection, two Variac autotransformers will control a three-phase load from a three-phase source. Maximum output voltage can be either line voltage or 17 percent above line voltage. The load rating of a two-gang, open-delta circuit is 1.732 times that of a single unit. With 240-volt models, output voltages of more than double the supply voltage can be obtained, although current and power ratings are halved. **Wye Connection:** Wye-connected models can be operated from three-phase lines of twice the voltage rating. This is because the voltage across each leg of a wye-connected assembly equals line volts divided by  $\sqrt{3}$ , and because 120-volt models are wound for a maximum of 140 volts and 240-volt models are wound for a maximum of 280 volts. With a wye connection, the voltage across a unit on a 480-volt line is 277 volts, and on a 240-volt line it is 138 volts. Although the overvoltage

feature is sacrificed in this circuit, the kva rating is increased by the ratio 138:120. The load rating of a wye-connected assembly is 3.47 times that of a single unit.

As with single-phase assemblies, Variac autotransformers can also be paralleled on three-phase circuits. A 4-gang delta connection requires two TYPE 50-P1 Chokes and a 6-gang delta connection requires two TYPE 50-P1 and two TYPE 50-P2 Chokes. A 6-gang wye requires three TYPE 50-P1 Chokes.

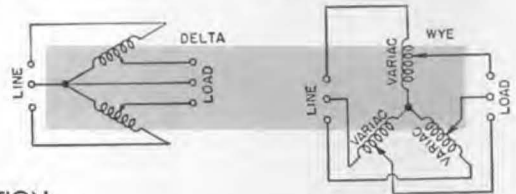

## SERIES OPERATION

The series connection is useful in the operation of 120-volt units from 240-volt lines and 240-volt units from 480-volt lines. This circuit cannot be used, however, when a common connection between line and load is required, as, for instance, when the load is grounded.

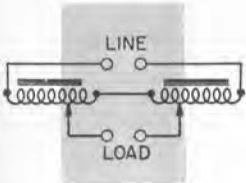

Type W2G3M, a three-gang, cased Variac autotransformer.



Type 50-P1 Choke for limiting circulating current in parallel combinations.

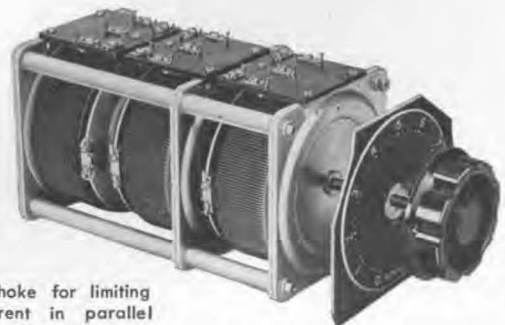

A three-gang uncased model, Type W20G3.





## RATINGS for SINGLE-PHASE W-SERIES GANGED VARIAC® ASSEMBLIES

This table lists commonly used ganged assemblies and does not include all possible applications.

INPUT VOLTAGE	OUTPUT				TYPE	DESCRIPTION (SEE NOTE B)	NUMBER OF CHOKES REQUIRED		NET WEIGHT POUNDS	APPROXIMATE SHIPPING WEIGHT—POUNDS	CODE WORD	PRICE	ADD FOR BALL BEARINGS (NOTE C)
	KVA LOAD RATING (SEE NOTE A)	VOLTAGE RANGE	RATED CURRENT AMPERES	MAXIMUM CURRENT AMPERES (SEE NOTE A)			TYPE 50-P1 \$16.00	TYPE 50-P2 \$16.00					
120	2.2	0-120	14.2	18.4	W5LG2M*	2-Gang, cased (P)	1		15¼	23	COTUGBONDU	\$53.00	\$8.00
120	2.6	0-120	17.0	22.0	W5LG2*	2-Gang, uncased (P)	1		13¾	21	COTUGGANDU	41.00	8.00
120	3.3	0-120	21.3	27.6	W5LG3M*	3-Gang, cased (P)	1	1	22½	32	COTUGBONTY	71.50	10.00
120	4.0	0-120	25.5	33.0	W5LG3*	3-Gang, uncased (P)	1	1	20½	30	COTUGGANTY	59.50	10.00
120	6.2	0-140	40.0	52.0	W20G2M	2-Gang, cased (P)	1		48	63	FEDALBONDU	131.00	10.00
120	6.2	0-140	40.0	52.0	W20G2	2-Gang, uncased (P)	1		43½	57	FEDALGANDU	106.00	10.00
120	7.7	0-140	56.0	64.0	W30G2M	2-Gang, cased (P)			67	83	KALALBONDU	190.00	14.00
120	8.6	0-140	60.0	72.0	W30G2	2-Gang, uncased (P)			61½	77	KALALGANDU	160.00	14.00
120	9.4	0-140	60.0	78.0	W20G3M	3-Gang, cased (P)	1	1	71	84	FEDALBONTY	182.00	12.00
120	9.4	0-140	60.0	78.0	W20G3	3-Gang, uncased (P)	1	1	65	78	FEDALGANTY	156.00	12.00
120	10.8	0-140	80.0	90.0	W50G2M	2-Gang, cased (P)	1		123	160	GATALBONDU	310.00	20.00
120	11.5	0-140	84.0	96.0	W30G3M	3-Gang, cased (P)			99	115	KALALBONTY	275.00	17.50
120	12.0	0-140	100.0	100.0	W50G2	2-Gang, uncased (P)	1		112	147	GATALGANDU	250.00	20.00
120	13.0	0-140	90.0	108.0	W30G3	3-Gang, uncased (P)			93	108	KALALGANTY	240.00	17.50
120	16.2	0-140	120.0	135.0	W50G3M	3-Gang, cased (P)	1	1	179	221	GATALBONTY	440.00	25.00
120	18.0	0-140	150.0	150.0	W50G3	3-Gang, uncased (P)	1	1	163	206	GATALGANTY	385.00	25.00
120	21.6	0-140	160.0	180.0	W50G4BBM	4-Gang, Ball Bearings, cased (P)	4		240	313	GATALBONKA	600.00	—
120	24.0	0-140	200.0	200.0	W50G4BB	4-Gang, Ball Bearings, uncased (P)	4		215	288	GATALGANKA	540.00	—
120	32.4	0-140	240.0	270.0	W50G6BBM	6-Gang, Ball Bearings, cased (P)	5	2	355	430	GATALBONSA	870.00	—
120	36.0	0-140	300.0	300.0	W50G6BB	6-Gang, Ball Bearings, uncased (P)	5	2	325	400	GATALGANSA	800.00	—
240	0.62	0-560	1.0	1.3	W5HG2	2-Gang, uncased (S) †			13¼	21	JOBALGANDU	49.00	8.00
240	0.62	0-560	1.0	1.3	W5HG2M	2-Gang, cased (S) †			15	23	JOBALBONDU	61.00	8.00
240	0.62	0-280	2.0	2.6	W2G2M	2-Gang, cased (S) †			8½	15	BAGALBONDU	48.00	7.00
240	0.74	0-280	2.4	3.1	W2G2	2-Gang, uncased (S) †			7¼	14	BAGALGANDU	36.00	7.00
240	1.56	0-280	5.0	6.5	W5G2M	2-Gang, cased (S) †			15	23	COTALBONDU	54.00	8.00
240	1.87	0-280	6.0	7.8	W5G2	2-Gang, uncased (S) †			13¾	21	COTALGANDU	42.00	8.00
240	3.12	0-280	10.0	13.0	W10G2	2-Gang, uncased (S) †			25½	34	DOGALGANDU	72.00	9.00
240	3.12	0-280	10.0	13.0	W10G2M	2-Gang, cased (S) †			29½	38	DOGALBONDU	93.00	9.00
240	4.99	0-280	16.0	20.8	W20HG2	2-Gang, uncased (P)	1		41	55	MEPALGANDU	110.00	10.00
240	4.99	0-280	16.0	20.8	W20HG2M	2-Gang, cased (P)	1		45	59	MEPALBONDU	135.00	10.00
240	6.24	0-280	20.0	26.0	W20G2	2-Gang, uncased (S) †			44	57	FEDALGANDU	106.00	10.00
240	6.24	0-280	20.0	26.0	W20G2M	2-Gang, cased (S) †			48	63	FEDALBONDU	131.00	10.00
240	7.5	0-280	24.0	31.2	W30HG2	2-Gang, uncased (P)	1		59	75	ZABALGANDU	160.00	14.00
240	7.5	0-280	24.0	31.2	W30HG2M	2-Gang, cased (P)	1		64½	81	ZABALBONDU	190.00	14.00
240	7.7	0-280	28.0	32.0	W30G2M	2-Gang, cased (S) †			67	83	KALALBONDU	190.00	14.00
240	8.6	0-280	30.0	36.0	W30G2	2-Gang, uncased (S) †			61½	77	KALALGANDU	160.00	14.00
240	14.9	0-280	40.0	62.0	W50HG2M	2-Gang, cased (P)	1		126	165	NITALBONDU	310.00	20.00
240	15.6	0-280	50.0	65.0	W50HG2	2-Gang, uncased (P)	1		116	153	NITALGANDU	260.00	20.00
240	22.3	0-280	60.0	93.0	W50HG3M	3-Gang, cased (P)	1	1	183	230	NITALBONTY	440.00	25.00
240	23.4	0-280	75.0	97.5	W50HG3	3-Gang, uncased (P)	1	1	167	214	NITALGANTY	385.00	25.00
240	29.8	0-280	80.0	124.0	W50HG4BBM	4-Gang, Ball Bearings, cased (P)	3		255	328	NITALBONKA	600.00	—
240	31.2	0-280	100.0	130.0	W50HG4BB	4-Gang, Ball Bearings, uncased (P)	3		230	300	NITALGANKA	540.00	—
240	44.6	0-280	120.0	186.0	W50HG6BBM	6-Gang, Ball Bearings, cased (P)	4	1	385	458	NITALBONSA	870.00	—
240	46.8	0-280	150.0	195.0	W50HG6BB	6-Gang, Ball Bearings, uncased (P)	4	1	355	428	NITALGANSA	800.00	—

See footnotes on following page.







# RATINGS

for

## THREE-PHASE W-SERIES GANGED VARIAC® ASSEMBLIES

This table lists commonly used ganged assemblies and does not include all possible applications.

INPUT VOLTAGE	OUTPUT				TYPE	DESCRIPTION	NUMBER OF CHOKES REQUIRED	NET WEIGHT POUNDS	APPROXIMATE SHIPPING WEIGHT — POUNDS	CODE WORD	PRICE	ADD. FOR BALL BEARINGS (NOTE C)
	KVA LOAD RATING (SEE NOTE A)	VOLTAGE RANGE	RATED CURRENT AMPERES	MAXIMUM CURRENT AMPERES (SEE NOTE A)								
208	3.31	0-208	7.1	9.2	W5LG3M <sup>‡</sup>	3-Gang, cased, Wye circuit		22½	32	COTUGBONTY	\$71.50	\$10.00
208	3.96	0-208	8.5	11.0	W5LG3 <sup>‡</sup>	3-Gang, uncased, Wye circuit		20½	30	COTUGGANTY	\$59.50	10.00
240	1.08	0-280	2.0	2.6	W5HG2	2-Gang, uncased, Open Delta		13½	21	JOBALGANDU	49.00	8.00
240	1.08	0-280	2.0	2.6	W5HG2M	2-Gang, cased, Open Delta		14	23	JOBALBONDU	61.00	8.00
240	1.08	0-240	2.0	2.6	W2G3M <sup>‡</sup>	3-Gang, cased, Wye circuit		12½	21	BAGALBONTY	64.00	9.00
240	1.29	0-240	2.4	3.1	W2G3 <sup>‡</sup>	3-Gang, uncased, Wye circuit		10¾	19	BAGALGANTY	52.00	9.00
240	2.16	0-280	4.0	5.2	W10HG2	2-Gang, uncased, Open Delta		24½	33	LUTALGANDU	76.00	9.00
240	2.16	0-280	4.0	5.2	W10HG2M	2-Gang, cased, Open Delta		29	37	LUTALBONDU	97.00	9.00
240	2.71	0-240	5.0	6.5	W5G3M <sup>‡</sup>	3-Gang, cased, Wye circuit		22½	32	COTALBONTY	73.00	10.00
240	3.24	0-240	6.0	7.8	W5G3 <sup>‡</sup>	3-Gang, uncased, Wye circuit		21	30	COTALGANTY	61.00	10.00
240	4.32	0-280	8.0	10.4	W20HG2	2-Gang, uncased, Open Delta		41	55	MEPALGANDU	110.00	10.00
240	4.32	0-280	8.0	10.4	W20HG2M	2-Gang, cased, Open Delta		45	59	MEPALBONDU	135.00	10.00
240	5.40	0-240	10.0	13.0	W10G3 <sup>‡</sup>	3-Gang, uncased, Wye circuit		39	48	DOGALGANTY	105.00	11.00
240	5.40	0-240	10.0	13.0	W10G3M <sup>‡</sup>	3-Gang, cased, Wye circuit		43	54	DOGALBONTY	128.00	11.00
240	6.48	0-280	12.0	15.6	W30HG2	2-Gang, uncased, Open Delta		59	75	ZABALGANDU	160.00	14.00
240	6.48	0-280	12.0	15.6	W30HG2M	2-Gang, cased, Open Delta		64½	81	ZABALBONDU	190.00	14.00
240	10.8	0-240	20.0	26.0	W20G3 <sup>‡</sup>	3-Gang, uncased, Wye circuit		65	78	FEDALGANTY	156.00	12.00
240	10.8	0-240	20.0	26.0	W20G3M <sup>‡</sup>	3-Gang, cased, Wye circuit		71	84	FEDALBONTY	182.00	12.00
240	12.9	0-280	20.0	31.0	W50HG2M	2-Gang, cased, Open Delta		126	165	NITALBONDU	310.00	20.00
240	13.3	0-240	28.0	32.0	W30G3M <sup>‡</sup>	3-Gang, cased, Wye circuit		99	115	KALALBONTY	275.00	17.50
240	13.5	0-280	25.0	32.5	W50HG2	2-Gang, uncased, Open Delta		116	153	NITALGANDU	260.00	20.00
240	15.0	0-240	30.0	36.0	W30G3	3-Gang, uncased, Wye circuit		93	108	KALALGANTY	240.00	17.50
240	18.7	0-240	40.0	45.0	W50G3M <sup>‡</sup>	3-Gang, cased, Wye circuit		179	221	GATALBONTY	440.00	25.00
240	20.8	0-240	50.0	50.0	W50G3 <sup>‡</sup>	3-Gang, uncased, Wye circuit		163	206	GATALGANTY	385.00	25.00
240	25.8	0-280	40.0	62.0	W50HG4BBM	4-Gang, cased, Open Delta	2	255	328	NITALBONKA	600.00	—
240	27.0	0-280	50.0	65.0	W50HG4BB	4-Gang, uncased, Open Delta	2	230	300	NITALGANKA	540.00	—
240	37.4	0-240	80.0	90.0	W50G6BBM <sup>‡</sup>	6-Gang, cased, Wye circuit	3	355	430	GATALBONSA	870.00	—
240	41.6	0-240	100.0	100.0	W50G6BB <sup>‡</sup>	6-Gang, uncased, Wye circuit	3	325	400	GATALGANSA	800.00	—
480	2.16	0-480	2.0	2.6	W5HG3 <sup>‡</sup>	3-Gang, uncased, Wye circuit		20½	29	JOBALGANTY	71.50	10.00
480	2.16	0-480	2.0	2.6	W5HG3M <sup>‡</sup>	3-Gang, cased, Wye circuit		22	31	JOBALBONTY	83.50	10.00
480	4.32	0-480	4.0	5.2	W10HG3 <sup>‡</sup>	3-Gang, uncased, Wye circuit		36	46	LUTALGANTY	111.00	11.00
480	4.32	0-480	4.0	5.2	W10HG3M <sup>‡</sup>	3-Gang, cased, Wye circuit		42	52	LUTALBONTY	134.00	11.00
480	8.65	0-480	8.0	10.4	W20HG3 <sup>‡</sup>	3-Gang, uncased, Wye circuit		61	73	MEPALGANTY	162.00	12.00
480	8.65	0-480	8.0	10.4	W20HG3M <sup>‡</sup>	3-Gang, cased, Wye circuit		67	81	MEPALBONTY	188.00	12.00
480	13.0	0-480	12.0	15.6	W30HG3 <sup>‡</sup>	3-Gang, uncased, Wye circuit		90½	107	ZABALGANTY	240.00	17.50
480	13.0	0-480	12.0	15.6	W30HG3M <sup>‡</sup>	3-Gang, cased, Wye circuit		97	113	ZABALBONTY	275.00	17.50
480	25.8	0-480	20.0	31.0	W50HG3M <sup>‡</sup>	3-Gang, cased, Wye circuit		183	230	NITALBONTY	440.00	25.00
480	27.0	0-480	25.0	32.5	W50HG3 <sup>‡</sup>	3-Gang, uncased, Wye circuit		167	214	NITALGANTY	385.00	25.00
480	51.5	0-480	40.0	62.0	W50HG6BBM <sup>‡</sup>	6-Gang, cased, Wye circuit	3	385	458	NITALBONSA	870.00	—
480	54.0	0-480	50.0	65.0	W50HG6BB <sup>‡</sup>	6-Gang, uncased, Wye circuit	3	355	428	NITALGANSA	800.00	—

NOTES

A. Maximum current can be drawn at maximum voltage for the line-voltage connection only. Kva, as listed, = normal input line voltage times maximum current.  
 B. P = parallel windings; S = series windings.  
 C. When ordering a unit with ball bearings, add the suffix "—BB" to the

type number and the suffix BALLY to the code word.  
 \* For 60-cycle use only; no overvoltage connection provided.  
 † Do not use with grounded load.  
 ‡ Overvoltage connection not recommended.  
 § Can be used in Wye connection on 208-volt, 60-cycle, 3-phase line





# DIMENSIONS† OF W-SERIES GANGED VARIAC AUTOTRANSFORMER ASSEMBLIES



Type W2G3, uncased, 3-gang model.

**Ganged Types W2G2, W2G3 (uncased).**

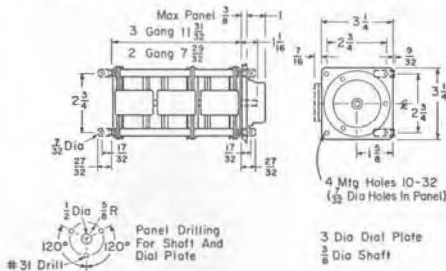

**Ganged Types W2G2M, W2G3M (cased).**

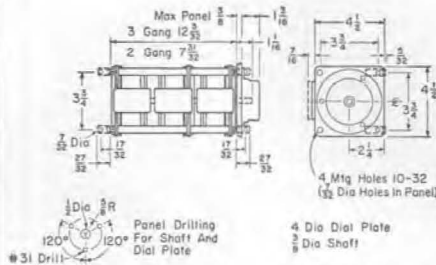
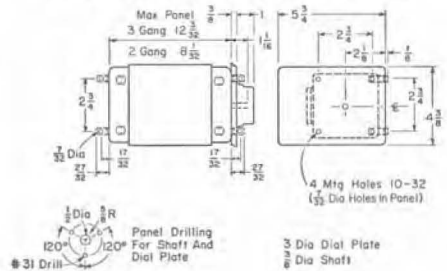

Ganged Types W5G2, W5G3, W5HG2, W5HG3, W5LG2, W5LG3 (uncased).

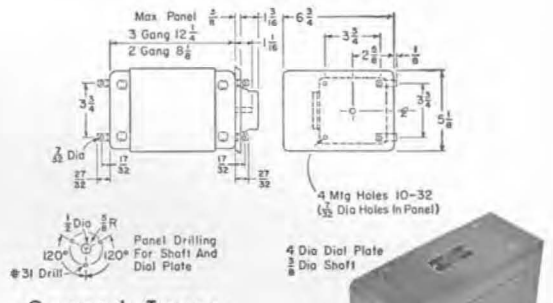

Ganged Types W5G2M, W5G3M, W5HG2M, W5HG3M, W5LG2M, W5LG3M (cased).

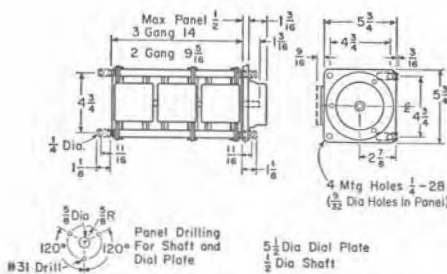

Ganged Types W10G2, W10G3, W10HG2, W10HG3 (uncased).

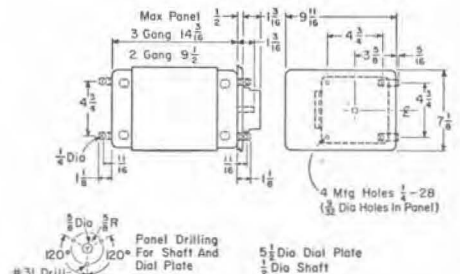

Ganged Types W10G2M, W10G3M, W10HG2M, W10HG3M (cased).



Type W10G2, 2-Gang Type W10 (uncased).

† Given in inches; to convert to mm, multiply by 25.4.



# DIMENSIONS† OF W-SERIES GANGED VARIAC® AUTOTRANSFORMER ASSEMBLIES



Type W20G3M, three-gang cased model.

Ganged Types W20G2M, W20G3M, W20HG2M, W20HG3M (cased).

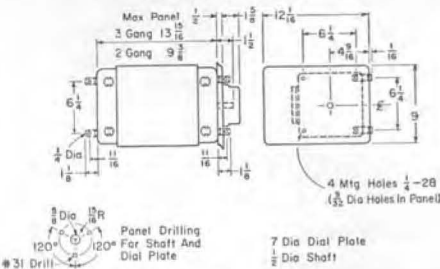

Ganged Types W20G2, W20G3, W20HG2, W20HG3 (uncased).

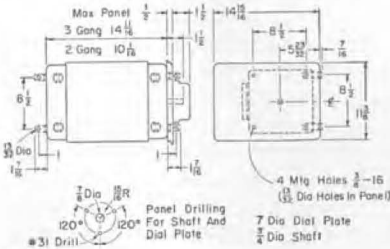
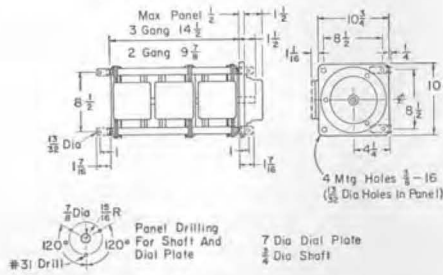

Ganged Types W30G2M, W30G3M, W30HG2M, W30HG3M (cased).



Type W30, 3-gang uncased model.

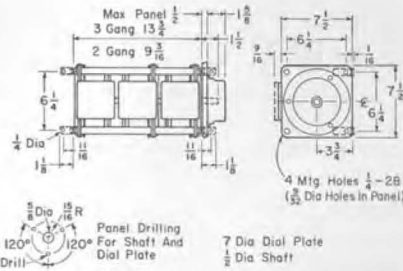

Ganged Types W30G2, W30G3, W30HG2, W30HG3 (uncased).

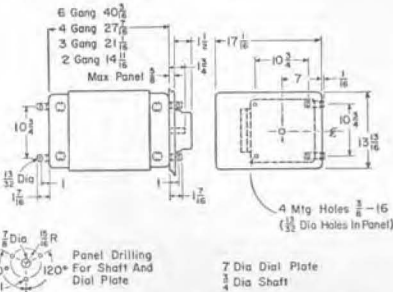

Ganged Types W50G2M, W50G3M, W50G4M, W50G6M, W50HG2M, W50HG3M, W50HG4M, W50HG6M (cased).

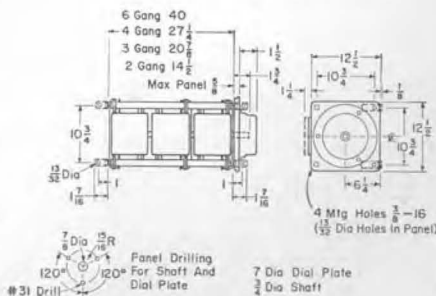

Ganged Types W50G2, W50G3, W50G4, W50G6, W50HG2, W50HG3, W50HG4, W50HG6 (uncased).

Type W50G2M, completely enclosed 2-gang Type W50.

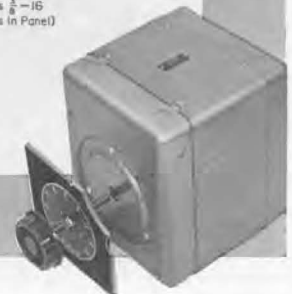

† Given in inches; to convert to mm, multiply by 25.4.



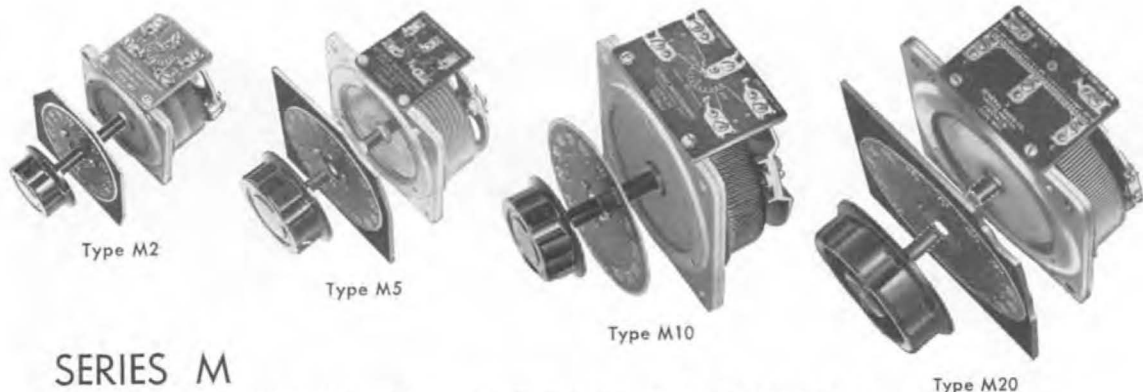

SERIES M

VARIAC® AUTOTRANSFORMERS

for 350- to 1200-Cycle Service

Series M Variac autotransformers are the high-frequency equivalents of the TYPES W2, W5, W10, and W20; they are designed for frequencies from 350 to 1200 cps. Mechanically similar to the 60-cycle Series W models, they are much smaller and lighter. Series M models are especially useful with the 400-cycle power supplies used in air-borne and marine equipment. The regulation obtained with the TYPE M units at 400 cps is considerably better than that of the 60-cycle models. Available in 2-, 5-, 10-, and 20-ampere single units, or in gangs, Series M units can be supplied with ball bearings and 60-cycle motor drives (pages 212 and 215).

FEATURES:

- Usable from 350 to 1200 cycles per second.
- DURATRAK coating process provides an extra factor of reliability under overloads.

Instantaneous peaks of ten times rated current can be tolerated.

- Brush track shows no significant wear after one million cycles of brush operation (zero to maximum and return).
- Manufactured to conform with military specifications for shock, vibration, salt-spray and tropicalization.
- Designed to provide excellent thermal conductivity between coil and base and between base and panel.
- Four corner mounting holes are provided for ganging and mounting, in addition to the three standard mounting holes (on radius).
- Contain wide-temperature-range lubrication which meets most military specifications.
- Two-ampere models (TYPE M2) have 400 turns, giving adequate resolution for many computing and control operations.
- Wiring diagram stamped on terminal board.

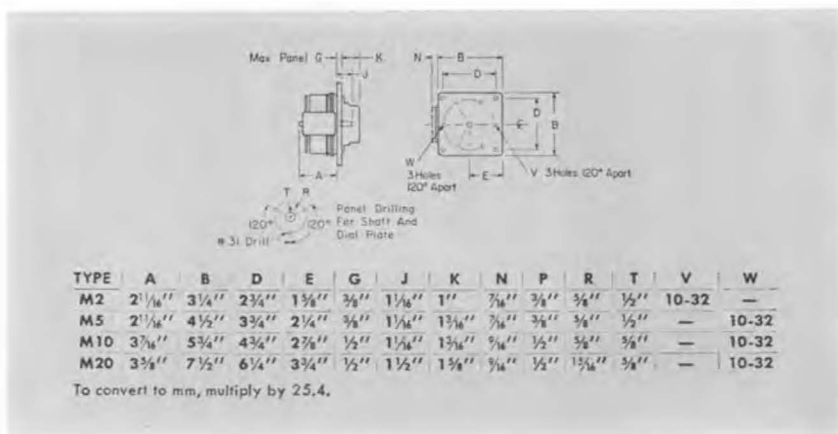



SERIES M SINGLE UNIT RATINGS AND PRICE LIST (UNCASED)

TYPE	RATED INPUT VOLTAGE	OUTPUT					400-CYCLE NO-LOAD LOSS, WATTS	DRIVING TORQUE OUNCE-INCHES	NET WEIGHT POUNDS	SHIPPING WEIGHT POUNDS (APPROX.)	CODE WORD	PRICE	ADD FOR REPLACEMENT BRUSH	ADD FOR BALL BEARINGS*	
		LINE-VOLTAGE CONNECTION			OVERVOLTAGE CONNECTION										
		OUTPUT KVA AT MAXIMUM OUTPUT VOLTAGE (NOTE A)	RATED OUTPUT CURRENT AMPERES	OUTPUT VOLTAGE RANGE	MAXIMUM OUTPUT CURRENT AMPERES (NOTE A)	OUTPUT VOLTAGE RANGE									RATED CURRENT AMPERES (NOTE B)
M2†	120	0.37	2.4	0-120	3.1	0-140	2.4	3.5	5-10	2	4	BAGGY	\$14.50	VB-1: 75¢	\$5.00
M5†	120	0.94	6	0-120	7.8	0-140	6	9	10-20	3½	6	CANNY	18.50	VB-2: 75¢	\$6.00
M10†	120	1.56	10	0-120	13	0-140	10	17	15-30	6½	11	CABIN	30.00	VBT-10: \$1.25	\$7.00
M20†	120	3.12	20	0-120	26	0-140	20	27	45-90	13	18	CAVIL	48.00	VBT-8: \$2.50	\$8.00

A. Maximum current can be drawn at maximum voltage for the line-voltage connection only. Maximum output voltage = line input voltage. Kva as listed = normal input line voltage × maximum current.  
 B. Rated current should not be exceeded for the overvoltage connection. Output kva for overvoltage connection = output voltage × rated current.  
 \*When ordering a unit with ball bearings, add the suffix "-BB" to the type number and the suffix "bally" to the code word.  
 †Approved by Canadian Standards Association.

SERIES M GANGED VARIAC® AUTOTRANSFORMER ASSEMBLIES

Series M models are available as two-gang assemblies for 120-volt, three-phase, open-delta connection (or for controlling two circuits from a single shaft) and as three-gang assemblies for 208- or 240-volt, three-phase, wye connection (or for controlling three circuits from a single shaft). Ganged assemblies

are designed to occupy minimum volume.

A TYPE 50-P1 Choke is required when a two-gang unit is to be operated in parallel; for three-gang combinations, a TYPE 50-P2 Choke is required in addition to the TYPE 50-P1.

Dials for ganged models are marked 0-10

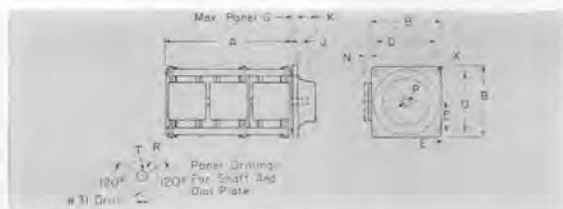

TYPE	A	B	D	E	G	J	K	N	P	R	T	X
M2G2	5 13/32"	3 1/4"	2 3/4"	1 5/8"	3/8"	1 1/4"	1"	7/8"	3/8"	5/8"	1/2"	10-32
M2G3	8 7/32"	3 1/4"	2 3/4"	1 5/8"	3/8"	1 1/4"	1"	7/8"	3/8"	5/8"	1/2"	10-32
M5G2	5 13/32"	4 1/2"	3 3/4"	2 1/4"	3/8"	1 1/4"	1 3/8"	7/8"	3/8"	5/8"	1/2"	10-32
M5G3	8 11/32"	4 1/2"	3 3/4"	2 1/4"	3/8"	1 1/4"	1 1/8"	7/8"	3/8"	5/8"	1/2"	10-32
M10G2	6 13/16"	5 3/4"	4 3/4"	2 7/8"	1/2"	1 3/4"	1 3/8"	7/8"	1/2"	5/8"	1/2"	1/4-28
M10G3	10 1/4"	5 3/4"	4 3/4"	2 7/8"	1/2"	1 3/4"	1 3/8"	7/8"	1/2"	5/8"	1/2"	1/4-28
M20G2	7 3/8"	7 1/2"	6 1/4"	3 3/4"	1/2"	1 1/2"	1 3/8"	7/8"	1/2"	1 3/16"	3/8"	1/4-28
M20G3	10 3/4"	7 1/2"	6 1/4"	3 3/4"	1/2"	1 1/2"	1 3/8"	7/8"	1/2"	1 3/16"	3/8"	1/4-28

SERIES M GANGED ASSEMBLY PRICE LIST (UNCASED)

TYPE	DESCRIPTION	DRIVING TORQUE (OZ.-IN.)	NET WEIGHT (LB.)	SHIPPING WEIGHT POUNDS	CODE WORD	PRICE	ADD FOR BALL BEARINGS*
M2G2	2-Gang M2	10-20	3¾	6	BAGGYGANDU	\$33.00	\$7.00
M2G3	3-Gang M2	15-30	5½	9	BAGGYGANTY	49.50	9.00
M5G2	2-Gang M5	20-40	6¾	12	CANNYGANDU	41.00	8.00
M5G3	3-Gang M5	30-60	10¼	14	CANNYGANTY	61.50	10.00
M10G2	2-Gang M10	30-60	12¼	18	CABINGANDU	65.00	9.00
M10G3	3-Gang M10	45-90	19	27	CABINGANTY	97.00	11.00
M20G2	2-Gang M20	90-180	26½	34	CAVILGANDU	107.00	10.00
M20G3	3-Gang M20	135-270	38	48	CAVILGANTY	155.00	12.00
Type 50-P1	Choke	—	1¼	1¾	PARALLCHOK	16.00	—
Type 50-P2	Choke	—	1¼	1¾	TRIPLECHOK	16.00	—

\*When ordering a unit with ball bearings, add the suffix "-BB" to the type number and the suffix "bally" to the code word.





AUTOTRANSFORMERS

MOTOR-DRIVEN VARIAC® AUTOTRANSFORMERS

All Variac® autotransformers, both single units and gangs, can be furnished with motor drive. The motor mounting plate is attached to the base by four posts, and the motor is geared to the shaft. All motor-driven models are equipped with ball bearings.

Fully enclosed, two-phase, gear-reduction motors of the servo type, having very low moments of inertia, are used. Three basic speeds are available, which, together with a selection of stocked standard coupling gears, make possible the assembly of units having nominal full-traverse rates of 2, 4, 8, 16, 32, 64, or 128 seconds at 60 cps (approximately 20% slower at 50 cps). The 2- and 4-second models are intended for high-speed servo applications. Those with slower traverse speeds are primarily for remote positioning requirements, although they are often used

for slower-speed servo work. Motors are 115-volt, 50/60-cycle units.

The two-phase motor supply may be derived from either (1) a servo amplifier or (2) the 115-volt line, with a capacitor (supplied) to produce the necessary phase shift.

Electrical limit switches are listed on all models to limit traverse to approximately 320°. However, they are not required on models with speeds of 2, 4, 8, or 16 seconds and they may be so ordered.\*

Cased, motor-driven models are available in either single units or gangs, and are similar to those used with Series W gangs.

In the tables on pages 214 and 215, available combinations are listed for each size. When less than 5 units are ordered, the setup charge must be included.

\* If microswitches are not desired, omit "K" from type number and subtract \$7.00 from listed price.

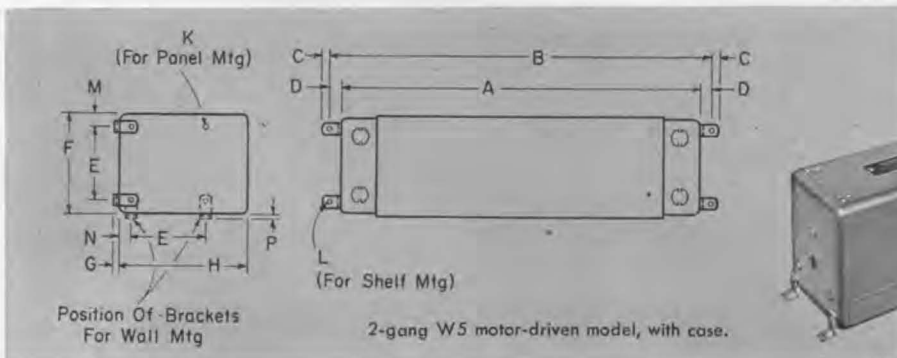

DIMENSIONS† OF MOTOR-DRIVEN CASED MODELS

	A	B	C	D	E	F	G	H	K	L	M	N	P
W2 Single	10 <sup>1</sup> / <sub>32</sub>	11 <sup>2</sup> / <sub>32</sub>	3/16	1 <sup>1</sup> / <sub>32</sub>	2 <sup>3</sup> / <sub>4</sub>	4 <sup>3</sup> / <sub>8</sub>	1/8	5 <sup>3</sup> / <sub>4</sub>	10-32	7/32 Drill	1 <sup>3</sup> / <sub>16</sub>	3/4	1/16
W2 2-Gang	13 <sup>23</sup> / <sub>32</sub>	14 <sup>2</sup> / <sub>32</sub>	3/16	1 <sup>1</sup> / <sub>32</sub>	2 <sup>3</sup> / <sub>4</sub>	4 <sup>3</sup> / <sub>8</sub>	1/8	5 <sup>3</sup> / <sub>4</sub>	10-32	7/32 Drill	1 <sup>3</sup> / <sub>16</sub>	3/4	1/16
W2 3-Gang	17 <sup>25</sup> / <sub>32</sub>	18 <sup>2</sup> / <sub>32</sub>	3/16	1 <sup>1</sup> / <sub>32</sub>	2 <sup>3</sup> / <sub>4</sub>	4 <sup>3</sup> / <sub>8</sub>	1/8	5 <sup>3</sup> / <sub>4</sub>	10-32	7/32 Drill	1 <sup>3</sup> / <sub>16</sub>	3/4	1/16
W5 Single	10 <sup>23</sup> / <sub>32</sub>	11 <sup>2</sup> / <sub>32</sub>	3/16	1 <sup>1</sup> / <sub>32</sub>	3 <sup>3</sup> / <sub>4</sub>	5 <sup>5</sup> / <sub>8</sub>	1/8	6 <sup>3</sup> / <sub>4</sub>	10-32	7/32 Drill	1 <sup>1</sup> / <sub>16</sub>	3/4	3/16
W5 2-Gang	13 <sup>27</sup> / <sub>32</sub>	14 <sup>2</sup> / <sub>32</sub>	3/16	1 <sup>1</sup> / <sub>32</sub>	3 <sup>3</sup> / <sub>4</sub>	5 <sup>5</sup> / <sub>8</sub>	1/8	6 <sup>3</sup> / <sub>4</sub>	10-32	7/32 Drill	1 <sup>1</sup> / <sub>16</sub>	3/4	3/16
W5 3-Gang	17 <sup>3</sup> / <sub>32</sub>	19 <sup>1</sup> / <sub>32</sub>	3/16	1 <sup>1</sup> / <sub>32</sub>	3 <sup>3</sup> / <sub>4</sub>	5 <sup>5</sup> / <sub>8</sub>	1/8	6 <sup>3</sup> / <sub>4</sub>	10-32	7/32 Drill	1 <sup>1</sup> / <sub>16</sub>	3/4	3/16
W10 Single	12 <sup>3</sup> / <sub>16</sub>	13 <sup>1</sup> / <sub>16</sub>	7/16	1 <sup>1</sup> / <sub>16</sub>	4 <sup>3</sup> / <sub>4</sub>	7 <sup>1</sup> / <sub>8</sub>	3/16	9 <sup>1</sup> / <sub>16</sub>	1/4-28	7/32 Drill	1 <sup>3</sup> / <sub>16</sub>	1 <sup>1</sup> / <sub>4</sub>	3/16
W10 2-Gang	15 <sup>3</sup> / <sub>8</sub>	17 <sup>1</sup> / <sub>4</sub>	7/16	1 <sup>1</sup> / <sub>16</sub>	4 <sup>3</sup> / <sub>4</sub>	7 <sup>1</sup> / <sub>8</sub>	3/16	9 <sup>1</sup> / <sub>16</sub>	1/4-28	7/32 Drill	1 <sup>3</sup> / <sub>16</sub>	1 <sup>1</sup> / <sub>4</sub>	3/16
W10 3-Gang	20 <sup>3</sup> / <sub>16</sub>	21 <sup>3</sup> / <sub>16</sub>	7/16	1 <sup>1</sup> / <sub>16</sub>	4 <sup>3</sup> / <sub>4</sub>	7 <sup>1</sup> / <sub>8</sub>	3/16	9 <sup>1</sup> / <sub>16</sub>	1/4-28	7/32 Drill	1 <sup>3</sup> / <sub>16</sub>	1 <sup>1</sup> / <sub>4</sub>	3/16
W20 Single	12 <sup>3</sup> / <sub>16</sub>	13 <sup>7</sup> / <sub>16</sub>	7/16	1 <sup>1</sup> / <sub>16</sub>	6 <sup>1</sup> / <sub>4</sub>	9	1/16	12 <sup>1</sup> / <sub>16</sub>	1/4-28	7/32 Drill	1 <sup>3</sup> / <sub>16</sub>	1 <sup>3</sup> / <sub>8</sub>	1/8
W20 2-Gang	15 <sup>3</sup> / <sub>8</sub>	17	7/16	1 <sup>1</sup> / <sub>16</sub>	6 <sup>1</sup> / <sub>4</sub>	9	1/16	12 <sup>1</sup> / <sub>16</sub>	1/4-28	7/32 Drill	1 <sup>3</sup> / <sub>16</sub>	1 <sup>3</sup> / <sub>8</sub>	1/8
W20 3-Gang	20 <sup>3</sup> / <sub>16</sub>	21 <sup>1</sup> / <sub>16</sub>	7/16	1 <sup>1</sup> / <sub>16</sub>	6 <sup>1</sup> / <sub>4</sub>	9	1/16	12 <sup>1</sup> / <sub>16</sub>	1/4-28	7/32 Drill	1 <sup>3</sup> / <sub>16</sub>	1 <sup>3</sup> / <sub>8</sub>	1/8
W30 Single	12 <sup>3</sup> / <sub>16</sub>	14 <sup>3</sup> / <sub>16</sub>	7/16	1	8 <sup>1</sup> / <sub>2</sub>	11 <sup>3</sup> / <sub>8</sub>	3/16	14 <sup>1</sup> / <sub>16</sub>	3/8-16	13/32 Drill	1 <sup>7</sup> / <sub>16</sub>	1 <sup>1</sup> / <sub>2</sub>	1/4
W30 2-Gang	15 <sup>1</sup> / <sub>16</sub>	17 <sup>1</sup> / <sub>16</sub>	7/16	1	8 <sup>1</sup> / <sub>2</sub>	11 <sup>3</sup> / <sub>8</sub>	3/16	14 <sup>1</sup> / <sub>16</sub>	3/8-16	13/32 Drill	1 <sup>7</sup> / <sub>16</sub>	1 <sup>1</sup> / <sub>2</sub>	1/4
W30 3-Gang	20 <sup>3</sup> / <sub>16</sub>	22 <sup>1</sup> / <sub>16</sub>	7/16	1	8 <sup>1</sup> / <sub>2</sub>	11 <sup>3</sup> / <sub>8</sub>	3/16	14 <sup>1</sup> / <sub>16</sub>	3/8-16	13/32 Drill	1 <sup>7</sup> / <sub>16</sub>	1 <sup>1</sup> / <sub>2</sub>	1/4
W50 Single	14 <sup>1</sup> / <sub>16</sub>	16 <sup>1</sup> / <sub>16</sub>	7/16	1	10 <sup>3</sup> / <sub>4</sub>	13 <sup>1</sup> / <sub>16</sub>	1/4	17 <sup>1</sup> / <sub>16</sub>	3/8-16	13/32 Drill	1 <sup>1</sup> / <sub>2</sub>	1 <sup>5</sup> / <sub>8</sub>	3/16
W50 2-Gang	21 <sup>1</sup> / <sub>16</sub>	23 <sup>1</sup> / <sub>16</sub>	7/16	1	10 <sup>3</sup> / <sub>4</sub>	13 <sup>1</sup> / <sub>16</sub>	1/4	17 <sup>1</sup> / <sub>16</sub>	3/8-16	13/32 Drill	1 <sup>1</sup> / <sub>2</sub>	1 <sup>5</sup> / <sub>8</sub>	3/16
W50 3-Gang	27 <sup>1</sup> / <sub>16</sub>	29 <sup>1</sup> / <sub>16</sub>	7/16	1	10 <sup>3</sup> / <sub>4</sub>	13 <sup>1</sup> / <sub>16</sub>	1/4	17 <sup>1</sup> / <sub>16</sub>	3/8-16	13/32 Drill	1 <sup>1</sup> / <sub>2</sub>	1 <sup>5</sup> / <sub>8</sub>	3/16

† Given in inches; to convert to mm, multiply by 25.4.



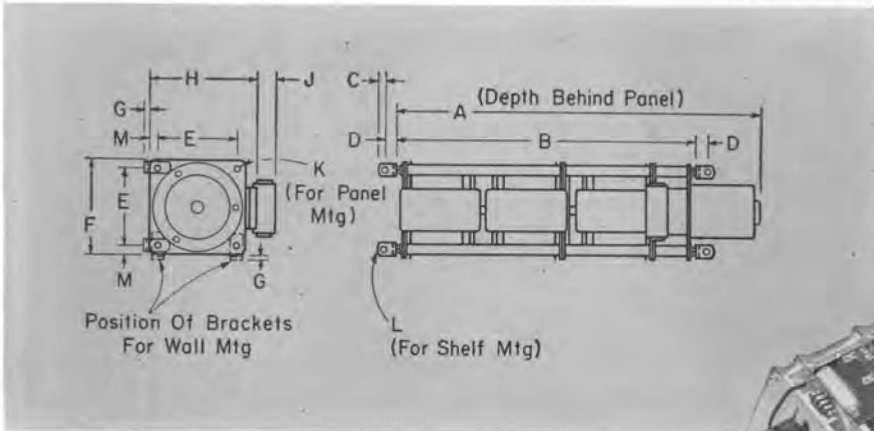

3-gang W20 motor-driven model.



## DIMENSIONS† OF MOTOR-DRIVEN UNCASSED MODELS

### W-SERIES MODELS

	A	B	C	D	E	F	G	H	J	K	L	M
W2 Single	9 3/8	6 13/16	3/16	1 7/32	2 3/4	3 1/4	3/32	3 11/16	7/8	10-32	7/32 Drill	1/4
W2 2-Gang	12 1/2	9 1 7/32	3/16	1 7/32	2 3/4	3 1/4	3/32	3 11/16	7/8	10-32	7/32 Drill	1/4
W2 3-Gang	16 5/16	13 1 3/32	3/16	1 7/32	2 3/4	3 1/4	3/32	3 11/16	7/8	10-32	7/32 Drill	1/4
W5 Single	9 7/16	6 1 3/32	3/16	1 7/32	3 3/4	4 1/2	3/32	4 1 3/16	—	10-32	7/32 Drill	3/8
W5 2-Gang	12 5/16	9 1 7/32	3/16	1 7/32	3 3/4	4 1/2	3/32	4 1 3/16	—	10-32	7/32 Drill	3/8
W5 3-Gang	16 1 1/16	13 2 3/32	3/16	1 7/32	3 3/4	4 1/2	3/32	4 1 3/16	—	10-32	7/32 Drill	3/8
W10 Single	10 9/32	7 7/16	7/16	1 1/16	4 3/4	5 3/4	3/16	6 5/16	—	1/4-28	7/32 Drill	1/2
W10 2-Gang	13 2 3/32	11	7/16	1 1/16	4 3/4	5 3/4	3/16	6 5/16	—	1/4-28	7/32 Drill	1/2
W10 3-Gang	18 1 3/32	15 1 1/16	7/16	1 1/16	4 3/4	5 3/4	3/16	6 5/16	—	1/4-28	7/32 Drill	1/2
W20 Single	10 9/32	7 7/16	7/16	1 1/16	6 1/4	7 1/2	1/16	8 1/16	—	1/4-28	7/32 Drill	1/2
W20 2-Gang	13 2 3/32	10 7/8	7/16	1 1/16	6 1/4	7 1/2	1/16	8 1/16	—	1/4-28	7/32 Drill	1/2
W20 3-Gang	18 9/32	15 7/16	7/16	1 1/16	6 1/4	7 1/2	1/16	8 1/16	—	1/4-28	7/32 Drill	1/2
W30 Single	10 3/4	6 1/4	7/16	1	8 1/2	10	1/8	11 1 3/16	—	3/8-16	1 3/32 Drill	3/4
W30 2-Gang	14 3/8	9 3/8	7/16	1	8 1/2	10	1/8	11 1 3/16	—	3/8-16	1 3/32 Drill	3/4
W30 3-Gang	19	14 1/2	7/16	1	8 1/2	10	1/8	11 1 3/16	—	3/8-16	1 3/32 Drill	3/4
W50 Single	12 5/8	8 1/16	7/16	1	10 3/4	12 1/2	1/8	13 3/4	—	3/8-16	1 3/32 Drill	7/8
W50 2-Gang	19 1/16	14 1/2	7/16	1	10 3/4	12 1/2	1/8	13 3/4	—	3/8-16	1 3/32 Drill	7/8
W50 3-Gang	25 7/16	20 7/8	7/16	1	10 3/4	12 1/2	1/8	13 3/4	—	3/8-16	1 3/32 Drill	7/8

### M-SERIES MODELS

M2 Single	8 1/8	5 5/32	3/16	1 7/32	2 3/4	3 1/4	3/32	3 11/16	7/8	10-32	7/32 Drill	1/4
M2 2-Gang	10	7 1/32	3/16	1 7/32	2 3/4	3 1/4	3/32	3 11/16	7/8	10-32	7/32 Drill	1/4
M2 3-Gang	12 1 3/16	9 2 7/32	3/16	1 7/32	2 3/4	3 1/4	3/32	3 11/16	7/8	10-32	7/32 Drill	1/4
M5 Single	8 3/16	5 7/32	5/16	1 7/32	3 3/4	4 1/2	3/32	4 1 3/16	—	10-32	7/32 Drill	3/8
M5 2-Gang	10 1/16	7 3/32	5/16	1 7/32	3 3/4	4 1/2	3/32	4 1 3/16	—	10-32	7/32 Drill	3/8
M5 3-Gang	12 1 3/16	9 3 1/32	5/16	1 7/32	3 3/4	4 1/2	3/32	4 1 3/16	—	10-32	7/32 Drill	3/8
M10 Single	9 1/32	6 3/16	7/16	1 1/16	4 3/4	5 3/4	3/16	6 5/16	—	1/4-28	7/32 Drill	1/2
M10 2-Gang	11 1 11/32	8 1/2	7/16	1 1/16	4 3/4	5 3/4	3/16	6 5/16	—	1/4-28	7/32 Drill	1/2
M10 3-Gang	14 2 3/32	11 1 3/16	7/16	1 1/16	4 3/4	5 3/4	3/16	6 5/16	—	1/4-28	7/32 Drill	1/2
M20 Single	9 5/32	6 5/16	7/16	1 1/16	6 1/4	7 1/2	1/16	8 1/16	—	1/4-28	7/32 Drill	3/8
M20 2-Gang	11 2 3/32	8 3/8	7/16	1 1/16	6 1/4	7 1/2	1/16	8 1/16	—	1/4-28	7/32 Drill	3/8
M20 3-Gang	15 5/32	12 7/16	7/16	1 1/16	6 1/4	7 1/2	1/16	8 1/16	—	1/4-28	7/32 Drill	3/8

See following pages for Price List of motor-driven models.

† Given in inches; to convert to mm multiply by 25.4.





## PRICE LIST<sup>1</sup> FOR MOTOR-DRIVEN VARIAC® AUTOTRANSFORMERS

MOTOR  ALL MOTORS SHOWN ARE 60-CYCLE	STANDARD EXTERNAL GEAR RATIOS								ADD TO TYPE NUMBER <sup>3</sup>			SET-UP CHARGE PRORATED 1-4 UNITS	ADD FOR CASE	
	A	2:1	4:1						CAPACITOR	MICROSWITCH	CASED MODEL			
	B			2:1	4:1	8:1								
C							2:1	4:1	8:1					
SECONDS FOR 320° TRAVERSE <sup>2</sup>		2	4	8	16	32	32	64	128					
TYPE <sup>1</sup>														
M2	\$101.50	\$101.50	\$101.50	\$101.50	NA	\$101.50	\$101.50	SO	C	K		\$6.00	NA	
M2G2	122.00	122.00	122.00	122.00	NA	122.00	122.00	SO	C	K		6.00	NA	
M2G3	NA	140.50	140.50	140.50	NA	140.50	140.50	SO	C	K		6.00	NA	
M5	106.50	106.50	106.50	106.50	NA	106.50	106.50	SO	C	K		6.00	NA	
M5G2	131.00	131.00	131.00	131.00	NA	131.00	131.00	SO	C	K		6.00	NA	
M5G3	NA	153.50	153.50	153.50	NA	153.50	153.50	SO	C	K		6.00	NA	
M10	142.00	142.00	142.00	142.00	\$142.00	NA	142.00	\$142.00	C	K		12.00	NA	
M10G2	NA	179.00	179.00	179.00	179.00	NA	179.00	179.00	C	K		12.00	NA	
M10G3	NA	NA	213.00	213.00	213.00	NA	213.00	213.00	C	K		12.00	NA	
M20	NA	166.00	166.00	166.00	166.00	NA	166.00	166.00	C	K		12.00	NA	
M20G2	NA	NA	227.00	227.00	227.00	NA	227.00	227.00	C	K		12.00	NA	
M20G3	NA	NA	277.00	277.00	277.00	NA	277.00	277.00	C	K		12.00	NA	
W2	102.00	102.00	102.00	102.00	NA	102.00	102.00	NA	C	K	M	6.00	\$12.00	
W2G2	125.00	125.00	125.00	125.00	NA	125.00	125.00	NA	C	K	M	6.00	12.00	
W2G3	NA	143.00	143.00	143.00	NA	143.00	143.00	NA	C	K	M	6.00	12.00	
W5	106.00	106.00	106.00	106.00	NA	106.00	106.00	NA	C	K	M	6.00	16.00	
W5G2	132.00	132.00	132.00	132.00	NA	132.00	132.00	NA	C	K	M	6.00	16.00	
W5G3	NA	153.00	153.00	153.00	NA	153.00	153.00	NA	C	K	M	6.00	16.00	
W5L	105.50	105.50	105.50	105.50	NA	105.50	105.50	NA	C	K	M	6.00	16.00	
W5LG2	NA	131.00	131.00	131.00	NA	131.00	131.00	NA	C	K	M	6.00	16.00	
W5LG3	NA	151.50	151.50	151.50	NA	151.50	151.50	NA	C	K	M	6.00	16.00	
W5H	109.50	109.50	109.50	109.50	NA	109.50	109.50	NA	C	K	M	6.00	16.00	
W5HG2	139.00	139.00	139.00	139.00	NA	139.00	139.00	NA	C	K	M	6.00	16.00	
W5HG3	NA	163.50	163.50	163.50	NA	163.50	163.50	NA	C	K	M	6.00	16.00	
W10	135.00	135.00	135.00	135.00	135.00	NA	135.00	135.00	C	K	M	12.00	32.00	
W10G2	NA	178.00	178.00	178.00	178.00	NA	178.00	178.00	C	K	M	12.00	34.00	
W10G3	NA	NA	213.00	213.00	213.00	NA	213.00	213.00	C	K	M	12.00	36.00	
W10H	137.00	137.00	137.00	137.00	137.00	NA	137.00	137.00	C	K	M	12.00	32.00	
W10HG2	NA	182.00	182.00	182.00	182.00	NA	182.00	182.00	C	K	M	12.00	34.00	
W10HG3	NA	NA	219.00	219.00	219.00	NA	219.00	219.00	C	K	M	12.00	36.00	
TORQUE—OUNCE-INCHES	30	60	120	240	480	240	480	960						

**NOTES**

NA = not available. SO = available on special order only; prices on request.  
 Note: Microswitches, capacitors, and ball bearings are included in the above prices. If microswitches are not desired, omit "K" from type number and subtract \$7.00 from listed price.

<sup>1</sup> Prices in table are for quantities of 5 or more. Add appropriate set-up charge for quantities of 1 to 4.  
<sup>2</sup> Traverse speeds are nominal for 60-cycle supply. Actual speeds may vary ±15% from these values. Specify speed on order (e.g. D4, D32, etc.)  
<sup>3</sup> See page 200 for example of type numbers.







PRICE LIST<sup>1</sup> FOR MOTOR-DRIVEN MODELS (cont.)

MOTOR  ALL MOTORS SHOWN ARE 60-CYCLE	STANDARD EXTERNAL GEAR RATIOS								ADD TO TYPE NUMBER <sup>3</sup>			SET-UP CHARGE PRORATED 1-4 UNITS	ADD FOR CASE
	A	2:1	4:1	8:1	16:1	32:1	64:1	128:1	CAPACITOR	MICROSWITCH	CASED MODEL		
SECONDS FOR 320° TRAVERSE <sup>2</sup>		2	4	8	16	32	64	128					
TYPE <sup>1</sup>													
W20	SO	\$158.00	\$158.00	\$158.00	\$158.00	NA	\$158.00	\$158.00	C	K	M	\$12.00	\$35.00
W20G2	SO	SO	218.00	218.00	218.00	NA	218.00	218.00	C	K	M	12.00	38.00
W20G3	NA	SO	270.00	270.00	270.00	NA	270.00	270.00	C	K	M	12.00	41.00
W20H	SO	160.00	160.00	160.00	160.00	NA	160.00	160.00	C	K	M	12.00	35.00
W20HG2	SO	SO	222.00	222.00	222.00	NA	222.00	222.00	C	K	M	12.00	38.00
W20HG3	SO	SO	276.00	276.00	276.00	NA	276.00	276.00	C	K	M	12.00	41.00
W30	SO	207.00	207.00	207.00	207.00	NA	207.00	207.00	C	K	M	12.00	49.00
W30G2	NA	SO	SO	287.00	287.00	NA	287.00	287.00	C	K	M	12.00	53.00
W30G3	NA	NA	SO	SO	367.00	NA	367.00	367.00	C	K	M	12.00	57.00
W30H	SO	207.00	207.00	207.00	207.00	NA	207.00	207.00	C	K	M	12.00	49.00
W30HG2	NA	SO	SO	287.00	287.00	NA	287.00	287.00	C	K	M	12.00	53.00
W30HG3	NA	NA	SO	SO	367.00	NA	367.00	367.00	C	K	M	12.00	57.00
W50	NA	SO	SO	260.00	260.00	NA	260.00	260.00	C	K	M	12.00	55.00
W50G2	NA	NA	SO	SO	390.00	NA	390.00	390.00	C	K	M	12.00	60.00
W50G3	NA	NA	NA	SO	520.00	NA	520.00	520.00	C	K	M	12.00	65.00
W50G4	NA	NA	NA	SO	SO	NA	SO	650.00	C	K	M	—	70.00
W50G6	NA	NA	NA	NA	SO	NA	SO	910.00	C	K	M	—	80.00
W50H	SO	SO	SO	260.00	260.00	NA	260.00	260.00	C	K	M	12.00	55.00
W50HG2	NA	SO	SO	SO	390.00	NA	390.00	390.00	C	K	M	12.00	60.00
W50HG3	NA	NA	SO	SO	520.00	NA	520.00	520.00	C	K	M	12.00	65.00
W50HG4	NA	NA	SO	SO	SO	NA	SO	650.00	C	K	M	—	70.00
W50HG6	NA	NA	NA	SO	SO	NA	SO	910.00	C	K	M	—	80.00
TORQUE—OUNCE-INCHES		30	60	120	240	480	240	480					

NOTES

NA = not available. SO = available on special order only; prices on request.  
Note: Microswitches, capacitor, and ball bearings are included in the above prices. If microswitches are not desired, omit "K" from type number and subtract \$7.00 from listed price.

<sup>1</sup> Prices in table are for quantities of 5 or more. Add appropriate set-up charge for quantities of 1 to 4.

<sup>2</sup> Traverse speeds are nominal for 60-cycle supply. Actual speeds may vary  $\pm 1.5\%$  from these values.

<sup>3</sup> See page 200 for example of type numbers.





### TYPE 1590-A REMOTE CONTROL



The TYPE 1590-A Remote Control is a simple, accurate, servo control for the remote positioning of a motor-driven Variac® autotransformer. This control can be set for any desired voltage from zero to 140 volts. The remote, motor-driven autotransformer will automatically position itself for the same voltage. This voltage is indicated on an accurate quasi-rms panel meter.

Since this control is a servomechanism, any change in output voltage due to Variac regulation is automatically corrected. The correction rate depends on the size of the Variac autotransformer and can be as high as 60 volts per second for small units.

If a regulated line is available to supply a small amount of power to operate the Remote Control, corrections can also be automatically obtained for fluctuations in line voltage at the remote autotransformer. This regulated line must have low impedance at 60 cps and must have the same phase angle as the unregulated

line to the remote unit. This combination can provide large amounts of power at a regulated voltage which is adjustable from zero to 140 volts. The addition of a buck-boost transformer, to limit the correction range to  $\pm 10\%$  about the normal line voltage, will result in an increase of five times in the power rating.

Knockouts and a terminal strip are provided in the case for the four leads necessary to connect the Control Unit to the remote Variac autotransformer.

If continuous control is not required, one TYPE 1590-A can be switched to control any number of remote units, one at a time.

#### TRAVERSE TIME AND CORRECTION RATE FOR 2% POSITIONING ERROR

DRIVEN VARIAC AUTO-TRANSFORMER MODEL	SINGLE UNIT		TWO-GANG (G2)		THREE-GANG (G3)	
	Traverse Time* (Sec-onds)	Approximate Correction Rate (Volts/sec)	Traverse Time* (Sec-onds)	Approximate Correction Rate (Volts/sec)	Traverse Time* (Sec-onds)	Approximate Correction Rate (Volts/sec)
W2	2	60	2	60	4	30
W5	2	60	4	30	8	15
W10	4	30	8	15	16	8
W20	8	15	16	8	32	4
W30	16	8	32	4	32†	4
W50	32	4	64‡	2	64‡	2

\* If half the positioning error is desired, the traverse time can be doubled, giving half the correction rate. Traverse time greater than 64 seconds should not be used.  
 † 3% positioning error.

To order the proper motor-driven Variac autotransformer, use the same type-numbering system as for our standard motor-driven units (page 200). The motor capacitor and microswitches, specified by C and K in the type numbers for standard units, are not used with the TYPE 1590-A.‡ These letters should be omitted from the type numbers. Thus, for 2% positioning accuracy with a TYPE W10G2 Variac autotransformer, order TYPE W10G2DS.

‡ Exception: microswitches necessary on 64-second models.

#### SPECIFICATIONS

**Tracking Accuracy:**  $\pm 2\%$  of input line voltage, when used with motor speeds listed in the table. (Halving the speed increases the accuracy to  $\pm 1\%$ ).

**Correction Rate:** See table.

**Power:** 105 to 125 volts, 50 to 60 cps.

**Accessories Required:** Standard motor-driven Variac autotransformer less capacitor and microswitches.

**Dimensions:** Width  $4\frac{1}{8}$ , height  $6\frac{3}{8}$ , depth  $5\frac{7}{8}$  inches (124 by 169 by 149 mm) over-all.

**Net Weight:**  $6\frac{1}{2}$  pounds (3 kg).

TYPE	CODE WORD	PRICE
1590-A Remote Control	REMCO	\$95.00



**BALL BEARINGS**

Series W and Series M models can be supplied with ball bearings, which provide more precise alignment, with slightly lower and more nearly constant torque.

When ordering a single unit or gang equipped with ball bearings, add the suffix "-BB" to the type number, the suffix **BALLY**

to the code word, and add the price shown in the tables.

Ball bearings are standard equipment on all motor-driven units and on all 4- and 6-gang W50 and W50H models, and are included in the price.

**SPECIAL VARIAC AUTOTRANSFORMERS**

Special models can be supplied to meet specific requirements, such as with additional winding taps, fungicide treatment, special shaft lengths, or with voltage outputs or ranges differing from those of standard models. They can also be supplied on special order

less knob, dial, etc., at lower net prices and with slightly extended delivery time.

The General Radio Company welcomes inquiries on special models, and is glad to furnish them when the quantities involved are sufficient to make production economically practicable.



Type W5MT3A

**METERED VARIAC®  
AUTOTRANSFORMERS**

Type W5MT3AW



Metered Variac autotransformer assemblies are portable testing devices, each consisting of a Variac autotransformer, a voltmeter, and an ammeter or wattmeter or both. Switching, fuses, and power cord are also provided. These handy, compact assemblies have many uses both in the laboratory and on the test bench, among them overvoltage and undervoltage tests, measurements of voltage, current, and power, and trouble shooting. The meter shielding reduces stray fields sufficiently to permit an over-all accuracy of 3% (full scale) with 2% meters. Connections are made through a three-wire cord (line) and a three-wire outlet (load). The output (load) circuit, containing the meters, is fused. A double-pole on-off switch disconnects both sides of the line. Make-

before-break range switches permit the dual-range meters to be switched under load. All meters have expanded scales for easier reading.

Two models include a voltmeter and ammeter: TYPE W5MT3A (0-5 amperes) and TYPE W10MT3A (0-10 amperes); two models include a voltmeter and wattmeter: TYPE W5MT3W (0-750 watts) and TYPE W10MT3W (0-1500 watts); one model includes a voltmeter, ammeter, and wattmeter: TYPE W5MT3AW (0-5 amperes and 0-750 watts).

The metal case enclosing the metered units is finished to match the case used with the standard Series W Variac autotransformers. A convenient carrying handle assures ready portability.

**METERED VARIAC AUTOTRANSFORMER RATINGS AND PRICES**

TYPE	METERS INCLUDED	INPUT VOLTS*	OUTPUT VOLTAGE RANGE	VOLTMETER RANGE	AMMETER RANGES	WATTMETER RANGES	60-CYCLE NO-LOAD LOSS—WATTS	FUSING AMPERES		WEIGHT POUNDS		DIMENSIONS INCHES			CODE WORD	PRICE
								LOW RANGE	HIGH RANGE	NET	SHIPPING	WIDTH	HEIGHT	DEPTH		
W5MT3A	V, A	120	0-140	0-150	0-1, 0-5	—	9	1	5	11½	19	6¾	10	6½	CABAL	\$85.00
W5MT3W	V, W	120	0-140	0-150	—	0-150, 0-750	9	2	5	11¾	19	6¾	10	6½	CABOB	110.00
W5MT3AW	V, A, W	120	0-140	0-150	0-1, 0-5	0-750	9	A=1 W=2	5	12½	20	12¾	9	6½	CABEX	150.00
W10MT3A	V, A	120	0-140	0-150	0-2, 0-10	—	17	2	10	18¼	24	9¼	12	6½	DOGEN	110.00
W10MT3W	V, W	120	0-140	0-150	—	0-300, 0-1500	17	4	10	18¼	24	9¼	12	6½	DOGID	138.00

V = Voltmeter    A = Ammeter    W = Wattmeter    \* 50 to 60 cps for all models.





HANDLES ANY LOAD UP TO 6 KVA

### TYPE 1570-A AUTOMATIC VOLTAGE REGULATOR

**USES:** The TYPE 1570-A Automatic Voltage Regulator is used in both laboratory and industrial applications where constant ac line voltage is required. It combines high accuracy for laboratory use with large capacity for industrial applications. Typical applications for this instrument include the regulation of line voltage for laboratories, computers, critical transmitter supplies, meter test benches, carefully controlled industrial processes, and military equipment installations.

**DESCRIPTION:** The TYPE 1570-A Automatic Voltage Regulator consists of a Variac® adjustable autotransformer, an auxiliary step-down transformer which multiplies the power rating of the autotransformer, and a servo-mechanism, which automatically controls the setting of the autotransformer to hold the output voltage constant.

The rectified output voltage is filtered and the dc component compared with voltage from a reference tube to obtain a dc error voltage. This error voltage is amplified by a two-

stage balanced amplifier with lead and lag networks that shape the phase and amplitude response for optimum performance.

The thyatron-controlled servo-motor is a true proportional control device rather than an off-on device and provides a smooth control with no "dead zone." The Variac auto-transformer driven by this servo-motor is equipped with ball bearings to reduce friction to a minimum.

In addition to the standard models listed below, a militarized model is also available (page 220).

**FEATURES:**

- No waveform distortion.
- High accuracy.
- Output voltage independent of load.
- No power-factor restrictions.
- Tolerates short-duration overloads.
- Adjustable output voltage.
- High efficiency.
- High response speed.
- High power-handling capacity.

The oscillograms below show traces of 60-cycle voltage sine-wave peaks illustrating the response speed of the Type 1570 Line Voltage Regulator. (a) Left, 2% change (step function) in voltage input to regulator; (b) center, voltage output of regulator as a result of 2% input voltage change shown in (a); (c) right, voltage output of regulator as the input voltage is changed 1%.

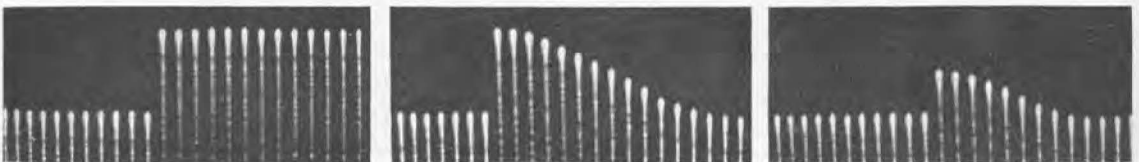



# VARIAC VOLTAGE REGULATORS

## SPECIFICATIONS

**Input Voltage Range:** The desired output voltage will be maintained if the input voltage does not vary by more than  $\pm 10\%$  from this value of output voltage. A range connection for  $\pm 20\%$  variation is also available.

**Output Voltage:** Adjustable over a range of  $\pm 10\%$  from a base value of 115 volts (for TYPE 1570-AL) or 230 volts (for TYPE 1570-AH) by means of a screwdriver adjustment on panel.

OUTPUT VOLTAGE	115 NOMINAL ADJUSTABLE $\pm 10\%$		230 NOMINAL ADJUSTABLE $\pm 10\%$	
	90% to 110%	80% to 120%	90% to 110%	80% to 120%
Input voltage as a percentage of output voltage*				
Output current, amperes	50	25	20	10
Approximate KVA	6	3	5	2.5
Accuracy in % of output voltage	0.25%	0.5%	0.25%	0.5%
Speed of Response, volts per second†	10	20	20	40

\* Types 1570-AL and 1570-AH can be connected for either  $\pm 10\%$  or  $\pm 20\%$  input voltage range. Instruments are shipped connected for  $\pm 10\%$  range unless  $\pm 20\%$  range is specified on order.  
† Slightly less for very small voltage corrections.

**Frequency:** 60-cycle models will operate from 55 to 65 cps; 50-cycle models from 45 to 55 cps.

**Power Consumption:** No Load, 35 watts  
Full Load, 100 watts

**Waveform Distortion:** None.

**Waveform Error:** The average value of the output voltage is held constant, and a loaded dc power supply, operated from the output of the regulator, will give constant out-

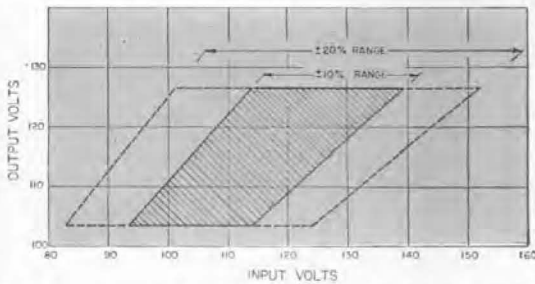

Range of operation for 115-volt models; for 230-volt models, multiply voltage scales by 2.

**View of wall-mounted regulator.** This model is used to regulate line voltages in the General Radio development and testing laboratories.



put voltage regardless of the harmonic distortion present in the power line. The rms output voltage will also remain constant, regardless of the harmonic distortion present, as long as the phase and amplitude of these harmonics are constant. If the harmonic content changes, the rms value will change by an amount less than  $\Delta R/n$ , where  $\Delta R$  is the change in the harmonic amplitude and  $n$  is the harmonic number.

**Ambient Temperature:** Full ratings apply up to 40 C.

**Tube Complement:** Two 12AX7, one 5651, two 5727.

**Terminals:** Two 15-ampere power cords, supplied with the instrument, may be used to connect the regulator when it is used as a portable instrument. Terminals are easily accessible when other connections are desired.

**Accessories Supplied:** Rack and table models — two power cords, spare fuses; wall models — cabinet, cover, and mounting screws.

**Mountings:** Relay Rack (-R model), Table (-M model) and Wall (-W model).

Dimensions:	RACK AND TABLE MODELS	WALL MODELS
Width	19 in. (485 mm)	13 1/2 in. (345 mm)
Height	7 in. (180 mm)	19 1/2 in. (495 mm)
Depth (over-all)	13 in. (330 mm)	8 1/4 in. (220 mm)
Depth (behind panel)	11 3/4 in. (300 mm)	
Weight	57 lb (26 kg)	64 lb (29 kg)

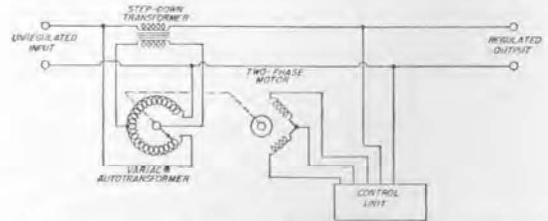

Elementary schematic diagram of the Type 1570 Voltage Regulator.

TYPE	DESCRIPTION	CODE WORD	PRICE
1570-ALM	Table Model, 115 volts, 60 cps	CEDAR	\$530.00
1570-ALR	Relay-Rack Model, 115 volts, 60 cps	CHARY	530.00
1570-ALW	Wall Model, 115 volts, 60 cps	CLOWN	530.00
1570-AHM	Table Model, 230 volts, 60 cps	CHALK	530.00
1570-AHR	Relay-Rack Model, 230 volts, 60 cps	CURLY	530.00
1570-AHW	Wall Model, 230 volts, 60 cps	CLOSE	530.00
1570-ALQ6*	115 volts, 50 cps	PASHA†	530.00
1570-AHQ11*	230 volts, 50 cps	REGAL†	530.00

\* Insert M, R, or W, for table, relay-rack, or wall model, respectively.

† Suffix: add to code word for corresponding 60-cycle model, i.e., CEDARPASHA for Type 1570-ALMQ6.  
PATENT NOTICE. See Note 7, page viii.





### MILITARIZED VOLTAGE REGULATOR—TYPE 1570-ALS15

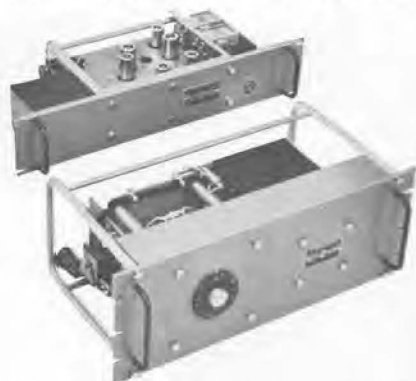

The TYPE 1570-ALS15 Automatic Voltage Regulator, a militarized version of the standard TYPE 1570-A, is designed to meet the requirements of MIL-E-1458B and MIL-E-16400C. It offers the same advantages: high accuracy, no distortion, large power rating, high efficiency, and excellent transient response.

For ease of maintenance, the Control Unit, containing the servo amplifier, has been separated from the Regulator Unit, which consists of the motor-driven Variac® autotransformer and buck-boost transformer. When service of the electronic circuitry is required, only the

smaller Control Unit need be removed. The Regulator Unit can remain in service supplying continuous (but unregulated) power.

The Regulator Unit is mounted on a U-beam extruded panel, which provides the ruggedness necessary to pass the standard 1200 ft-lb shock test and the vibration test of .030-inch excursion from 10-55 cps. The transformers are hermetically sealed and stainless steel or iridite-coated aluminum is used throughout. Suitable military lubricants are employed.

The Control Unit has been particularly designed for reliability and ease of maintenance, making it especially useful for applications at high ambient temperatures or for portable installations where mechanical shock or vibration is encountered. The highest quality components are used, hermetically sealed where possible. Most components are operated at less than half their voltage or power ratings. All vacuum tubes are the more reliable military types and are operated at less than 20% of their maximum plate-current ratings. All tubes can be replaced directly, without removal of any dust covers. The removal of a single top cover exposes all components and removal of the bottom plate exposes all wiring as well as a complete circuit diagram and parts list.

### SPECIFICATIONS

**Input Voltage:** The desired output voltage will be maintained if the input voltage does not vary by more than  $\pm 9\%$  from this value of output voltage. A connection range for  $\pm 18\%$  variation is also available.

**Output Voltage:** Adjustable over a range of  $\pm 10\%$  from a base value of 115 volts; internal screw driver adjustment.

OUTPUT VOLTAGE	115 NOMINAL ADJUSTABLE $\pm 10\%$	
	91% to 109%	82% to 118%
Input voltage as a percentage of output voltage*		
Output current, amperes	50	25
Approximate KVA	6	3
Accuracy in % of output voltage	0.25%	0.5%
Speed of Response, volts per second†	10	20

\* TYPE 1570-ALS15 can be connected for either  $\pm 9\%$  or  $\pm 18\%$  input voltage range. Instruments are shipped connected for  $\pm 9\%$  range unless  $\pm 18\%$  range is specified on order.

† Slightly less for very small voltage corrections.

**Frequency:** 45-55 or 55-65 cps, selected by switch inside the Control Unit.

**Power Consumption:** No load, 35 watts. Full load, 140 watts.

**Waveform Distortion:** None.

**Waveform Error:** The voltage-sensing device responds to the average value of rectified output voltage. Therefore, the average value of output voltage is held constant, and a loaded dc power supply, operated from the regulator output, will give constant output voltage regardless of the harmonic distortion in the power line. The rms output voltage will also remain constant regardless of the harmonic distortion present if the phase and amplitude of the harmonics are constant. If the harmonic content changes, the rms value will change by an amount less than  $\Delta R/n$ , where  $\Delta R$  is the change in the harmonic amplitude and  $n$  is the harmonic number.

**Ambient Temperature:** Operating —  $-29$  to  $+52$  C  
Storage —  $-54$  to  $+85$  C

**Tube Complement:** Two each, 5751 and 5727/2D21W; one each, 5651WA and 6626/0A2WA.

**Terminals:** Jones connector strip.

**Accessories Supplied:** Control Unit power cord, spare fuses.

**Mounting:** Relay rack.

Dimensions:	CONTROL UNIT	POWER UNIT
Width	19 in. (485 mm)	19 in. (485 mm)
Height	3½ in. (90 mm)	7 in. (180 mm)
Depth (over-all)	8½ in. (220 mm)	11¼ in. (290 mm)
Depth (behind panel)	7 in. (180 mm)	9¾ in. (245 mm)
Weight	13¼ lb (6.3 kg)	50 lb (22.8 kg)

TYPE	CODE WORD	PRICE
1570-ALS15	CLOTH	\$705.00

Automatic Voltage Regulator, 115 volts . . . . .



# VARIAC<sup>®</sup> SPEED CONTROLS



## FOR OPERATING DC MOTORS FROM AC LINES

Variac Speed Controls are compact, high-performance motor speed controls, designed to operate dc shunt, compound, or series motors from an ac line. The motors are operated with constant field excitation and adjustable armature voltage, obtained from a Variac autotransformer and rectifier, so that shunt motor regulation characteristics are obtained.

*No electronic tubes are used in these controls.*

Rectifiers are of the metallic or semiconductor type, so there is no time delay in starting.

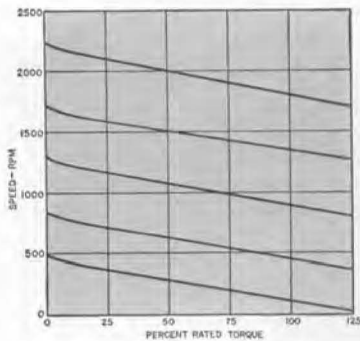

Speed-torque characteristics of a typical motor and speed control installation.

Variac Speed Controls are available in four power ratings:  $\frac{1}{15}$ ,  $\frac{1}{6}$ ,  $\frac{1}{3}$ , and  $\frac{3}{4}$  horsepower. They are simple and rugged, have good regulation, and are particularly suited to shop installation. They have given excellent performance in a wide variety of laboratory, machine-tool, and industrial applications.

For each size motor speed control, a basic model is available for assembly into other

equipment. These are identified by the suffix W in their type numbers. These models include the basic components of the mounted controls, but switching and overload protection must be supplied by the user.

Shown below is the basic circuit for the motor speed controls. Two sets of full-wave rectifiers are used. One set supplies fixed field voltage; the other a continuously adjustable armature voltage, controlled by a Variac autotransformer.

The choke in the armature circuit, in conjunction with the full-wave selenium rectifier, assures continuous conduction throughout the ac cycle, providing a low-impedance source of essentially ripple-free armature current.

Armature overload protection is accomplished with slow-blow fuses in the  $\frac{1}{15}$ - and  $\frac{1}{6}$ -hp models, and with magnetic circuit breakers in the  $\frac{1}{3}$ - and  $\frac{3}{4}$ -hp models.

### FEATURES:

- Smooth wide-range speed control — 15:1 for most applications; up to 100:1 or more with light or smooth loads.
- Versatile starting characteristics: smooth, controlled starting for delicate loads; fast, high-torque starting for heavy loads.
- Dynamic braking in all models  $\frac{1}{6}$  hp and higher brings the armature to a quick stop.
- Instant starting.
- Quick reversing.
- Negligible ac ripple — motor need not be derated — no torque pulsation.
- Low first cost.
- Very low maintenance. No electronic tubes.
- Simple installation.

PATENT NOTICE. See Note 7, page viii.

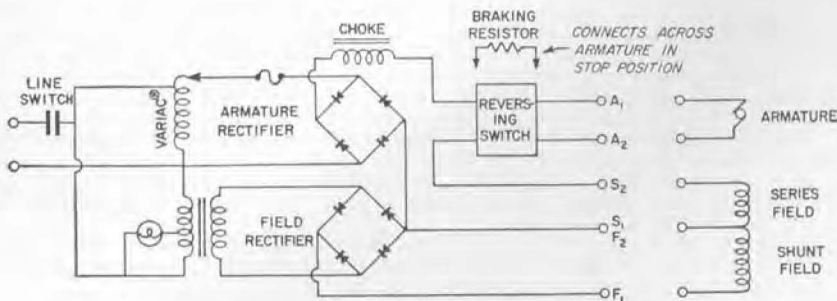

Circuit diagram of a Variac Speed Control.



### COMPLETE MODELS IN CABINET WITH SWITCHES 1/6, 1/3, and 3/4 HORSEPOWER



Type 1700-B



Type 1702-A

### TYPE 1703-A, TYPE 1700-B, AND TYPE 1702-A

These fractional-horsepower models are completely assembled with switching and control elements on the face of the cabinet.

Typical applications include feed and spindle drives, winding machines, grinders, drill presses, conveyors, and processing machinery.



Type 1700-CW

### BASIC (W) MODELS—ON CHASSIS WITH COVER TYPES 1703-BW, 1700-CW, AND 1702-BW

Basic models of the 1/6- to 3/4-hp controls, these models have the essential elements, including the braking resistor, mounted on a simplified chassis with cover. The Variac autotransformer is supplied separately, to be mounted by the customer. A suitable switch or drum controller can be supplied (page 223).

TYPE	MODEL	DC FIELD	SPEED	CODE WORD	UNIT PRICE			RECOMMENDED MOTOR
					1-4	5-19	20-up	
1703-A (1/6 hp)	Complete in Cabinet	115 v.	0-rated	WEBBY	\$110.00	\$107.00	\$104.00	MOD-11
		66 v.	0-1 1/4 x rated					
		48 v.	0-1 1/2 x rated					
1700-B (1/3 hp)	Complete in Cabinet	115 v.	0-rated	AFOOT	180.00	176.00	172.00	MOD-3
		75 v.	0-1.15 x rated					
1702-A (3/4 hp)	Complete in Cabinet	115 v.	0-rated	AMAZE	255.00	245.00	235.00	MOD-25
		75 v.	0-1.15 x rated					
1703-BW (1/6 hp)	Basic (Chassis with cover, and Variac autotransformer)	115 v.	0-rated	SABOT	90.00	87.50	85.00	MOD-11
		66 v.	0-1 1/4 x rated					
		48 v.	0-1 1/2 x rated					
1700-CW (1/3 hp)	Basic (Chassis with cover, and Variac autotransformer)	115 v.	0-rated	SALTY	155.00	151.50	148.00	MOD-3
		75 v.	0-1.15 x rated					
1702-BW (3/4 hp)	Basic (Chassis with cover, and Variac autotransformer)	115 v.	0-rated	SATIN	215.00	206.00	197.00	MOD-25
		75 v.	0-1.15 x rated					

**Input Line:** 105-125 v, 50-60 cps, 275 watts, for 1/6 hp 105-125 v, 60 cps, 560 and 1150 watts for 1/3, and 3/4 hp, respectively (50 cps available on special order).

**Armature Output:** 0-115 v, de at 1.5, 3.0, and 6.5 amp for 1/6, 1/3, and 3/4 hp respectively.

**Overload Protection:** Fuses in 1/6 hp and magnetic circuit breakers for 1/3 and 3/4 hp complete controls only.

**Motors:** MOD-11, 1/6 hp Compound, 1725 rpm, 25 lbs (11.5 kg), Code Word motor\*, Price \$62.00.

MOD-3, 1/3 hp Compound, 1725 rpm, 30 lb (14 kg), Code Word motor\*, Price \$70.00.

MOD-25, 3/4 hp, Compound with interpoles, 1725 rpm, 60 lb (27 kg), Code Word motor\*, Price \$115.00.

#### Dimensions and Weight:

1703: Cabinet Model, 7 1/8 by 7 3/4 by 5 5/8 inches (180 by 200 by 145 mm) over-all, 9 lb (4.1 kg); Basic Model, chassis 7 1/2 by 10 1/4 by 3 1/2 inches (190 by 260 by 90 mm), 4 1/2 lb (2.1 kg), Variac autotransformer 3 3/4 by 3 1/4 by 4 3/8 inches (85 by 95 by 110 mm), 3 1/2 lb (1.6 kg).

1700: Cabinet Model, 13 by 9 3/8 by 7 inches (330 by 240 by 180 mm) over-all, 23 1/2 lb (10.7 kg); Basic Model, chassis 9 3/4 by 12 3/4 by 5 inches (250 by 320 by 130 mm), 17 lb (7.7 kg), Variac autotransformer 4 1/2 by 5 by 5 1/2 inches (115 by 125 by 140 mm), 6 1/2 lb (3 kg).

1702: Cabinet Model, 13 1/4 by 15 1/4 by 7 1/8 inches (345 by 395 by 190 mm) over-all, 41 lb (18.7 kg); Basic Model, chassis 11 1/4 by 15 1/4 by 5 3/8 inches (235 by 390 by 150 mm), 27 1/2 lb (12.5 kg), Variac autotransformer 5 3/4 by 6 3/4 by 5 3/8 inches (145 by 160 by 150 mm), 11 1/4 lb (5.1 kg).

\* When ordering control with motor, use compound code word; for example, webnymotor is the code word for Type 1703-A with motor. Motors are not sold separately.





Type 1701-AK



Type 1701-AKW

Type 1705-P1 Controller



Type 1702-P3 Switch

### FULLY ENCLOSED MODELS—COMPLETE IN CABINET UP TO 1/15 HORSEPOWER

#### TYPES 1701-AK AND 1701-AM

For shunt motors, 1/15 hp and below.

Typical applications are: Feed drives for lathes, milling machines, grinders and punch presses; rewinding and take-up drives; jewelers' lathes and other very light machinery; photographic and other processing equipment. AK model has two speed ranges; AM model has one, and armature fuse is accessible from front panel.

#### TYPE 1701-AU

Like TYPE 1701-AK, but for series and universal motors. One speed range. Gives shunt regulation characteristics with inexpensive universal motor at speeds up to 10,000 rpm. Motor

field and armature leads must be separate.

Applications similar to TYPE 1701-AK, but including also higher speed applications, such as small, very high-speed drill presses.

#### BASIC (W) MODEL—OPEN CHASSIS TYPE 1701-AKW

Basic model of the 1/15-hp control. It contains the essential elements such as the choke, rectifiers, and transformers, mounted on a chassis, and the Variac autotransformer supplied as a separate unit, to be mounted by the customer. No switches or overload protection are supplied. They may be chosen by the customer to suit his applications.

TYPE	MODEL	DC FIELD	SPEED	CODE WORD	UNIT PRICE	RECOMMENDED MOTOR
1701-AK	Complete	115 v.	0-rated	WINDY	1-4 \$95.00	MOD-21
		38 v.	0-2 x rated		5-19 93.00	
1701-AM	in	115 v.	0-rated	WIDOW	20 up 91.00	MOD-21
1701-AU	Cabinet				10 v.	
		16 v.		5-19 93.00		
					20 up 91.00	
1701-AKW	Basic (Chassis and Variac autotransformer)	115 v.	0-rated	SERUM	1-4 72.00	MOD-21
		38 v.	0-2 x rated		5-19 68.50	
					20 up 65.50	

Input Line: 105-125 v, 60 cps or 105-120 v, 50 cps, 175 watts.

Armature Output: 0-115 v dc, 0.8 amp.

Motors: MOD-21 Shunt, 1/15 hp, 1725 rpm, 8 lb (3.6 kg), Code Word MOTOR\*, Price \$38.00.

MOD-4 Universal, 1/15 hp, 8800 rpm, 3 3/4 lb (1.7 kg), Code Word MOTOR\*, Price \$21.50.

Dimensions and Weight:

Cabinet Models: 5 7/8 by 6 7/8 by 4 5/8 inches (150 by 175 by 120 mm), over-all, 6 lb (2.7 kg).

Basic Models: Chassis, 6 1/8 by 9 by 2 3/4 inches (155 by 230 by 70 mm), 2 1/4 lb (1 kg); Variac autotransformer, 3 1/2 by 3 1/2 by 4 3/8 inches (85 by 95 by 110 mm), 3 1/2 lb (1.6 kg).

\* When ordering control with motor, use compound code word; for example, WINDYMOTOR is the code word for TYPE 1701-AK with motor. Motors are not sold separately.

#### SWITCH AND CONTROLLER for Use With 1/3-HP and 3/4-HP Basic Models

The appliance-type switch supplied with the TYPE 1700-B and TYPE 1702-A controls is available as a separate item, the TYPE 1702-P3 Switch, to use with the W Models. This switch has enough contacts to break the ac and dc circuits simultaneously, and also to handle reversing and dynamic braking. The escutcheon plate (supplied) is engraved FORWARD,

STOP and REVERSE. A drum switch, which is particularly suited for machine-shop production work, is also available as a separate item for use with the W models.

TYPE		CODE WORD	PRICE
1702-P3	Switch . . . . .	FLIPO	\$7.50
1705-P1	Drum Controller . . . . .	DRUMO	30.00



# WAVEFORM-MEASURING INSTRUMENTS



The choice of an instrument for evaluating the components of a complex electrical signal, an acoustic noise, or a mechanical vibration depends upon the character of the signal, the information that is needed, and how the results are to be used. For example, if the wave is a periodic one that is stable in frequency, each individual component is readily measured with the TYPE 736-A Wave Analyzer. The very high selectivity of this analyzer with its 4-cycle bandwidth is independent of the frequency to which the analyzer is tuned, because the analyzer is a heterodyne type. This selectivity characteristic, obtained by quartz-crystal filters, is invaluable in the measurement of intermodulation distortion of amplifiers and other audio equipment. As an electronic voltmeter in the measurement of the transmission characteristics of electrical wave filters and as a null detector for impedance bridges, the excellent selectivity is of particular value in avoiding the effects of interfering signals, hum, noise, and distortion products.

The TYPE 1554-A Sound and Vibration Analyzer, described in the section on Sound and Vibration, finds its greatest use in the measurement of the components of noise, either electrical or acoustical, when the selectivity of the TYPE 736-A Wave Analyzer is often too great for rapid analysis, and in the measurement of noises whose frequency components fluctuate. It provides two bandwidths, one a constant percentage (8%) of

the frequency to which its dial is set, the other a third octave.

Although its tuning is continuous, if one assumes that the analyzer separates its range from 2.5 to 25,000 cps into contiguous bands, according to its effective bandwidth, it will have about 100 bands without appreciable overlap, as contrasted with about 3200 bands for the full range of the wave analyzer.

When a still simpler division of the spectrum is desired, the TYPE 1550-A Octave-Band Noise Analyzer (described in the section on Sound and Vibration) is available for division of the spectrum from 20 to 10,000 cps into eight bands.

The TYPE 1932-A Distortion and Noise Meter is a more specialized, yet remarkably versatile analyzer, designed for the routine and rapid measurements on audio systems. This electronic voltmeter uses the complete signal as a reference value. A selective network suppresses the fundamental component, and the remainder, which includes distortion components, hum and noise, is then measured. This single-number distortion rating is a convenient and frequently used figure of merit of the performance of an audio-system.

Used with a cathode-ray oscillograph, it becomes a versatile production testing tool, immediately indicating optimum conditions, whenever adjustments are made that affect distortion or noise. Noise, distortion and hum are readily distinguished, and a distinction between second-harmonic and third-harmonic distortion can also be made.

TYPE	NAME	CLASS	FREQUENCY RANGE-CPS	TUNING METHOD	BANDWIDTH (3 DB)	INPUT VOLTAGE RANGE	MEASUREMENT APPLICATION	POWER SUPPLY	SEE PAGE
736-A	Wave Analyzer	Heterodyne 50-kc crystal filter	20-16,000	Continuous (1 range)	4 cps	10 microvolts to 300 volts	Separating steady components	AC Line	225
1554-A	Sound and Vibration Analyzer	RC Degen-erative	2.5-25,000 (4 ranges)	Continuous	8% and third octave	100 $\mu$ v to 3 v	Separating Components and Broad-Band Noise	Batteries	189
1550-A	Octave-Band Noise Analyzer	LC Filter	20-10,000	Band Switch (8 bands)	2:1	66 db	Broad-Band Noise	Battery	191
1932-A	Distortion and Noise Meter	RC Rejec-tion	50-15,000 (funda-mental)	Continuous (5 ranges)	Rejection band at 60 db = 0.02%	80 db	Harmonic Distortion — Relative Hum and Noise	AC Line	227





## TYPE 736-A WAVE ANALYZER

**USES:** The wave analyzer is used to measure the amplitude and frequency of the components of a steady-state complex electrical waveform. These include not only the components of harmonic distortion, but also those of intermodulation distortion, noise, and hum.

Specific uses of the TYPE 736-A Wave Analyzer include the measurement of distortion components in audio-frequency equipment, broadcast receivers and transmitters, telephone systems, public address equipment, oscillators, amplifiers, and vacuum-tube circuits in general; harmonic studies on electric power systems and electrical machinery; hum measurement in ac operated communication equipment; noise analysis; and induction studies on telephone lines. As a sharply tuned voltmeter, it is invaluable in the measurement of the transmission characteristics of electric wave filters and as a null detector for impedance bridges. It is an excellent detector for intermodulation distortion measurements.

**DESCRIPTION:** The TYPE 736-A Wave Ana-

lyzer is a heterodyne type of vacuum-tube voltmeter. The intermediate-frequency amplifier includes a highly selective filter using three quartz crystals. The use of a heterodyne method makes it possible to vary the response frequency while using a fixed-frequency filter.

The output of the local oscillator and the whole of the complex waveform to be examined are fed to a balanced modulator where their combination produces both the sum and difference frequencies, or sidebands, in the output. The original of the complex waveform is not passed by the modulator intermediate-frequency output transformer, and the local-oscillator carrier frequency is suppressed in the output because of the two-tube balanced modulator employed.

The 50-kilocycle component of the upper sideband, proportional to the voltage of that frequency present in the original wave to which the main dial is set, is selected and amplified by the intermediate stages. The step attenuators provided make it possible to measure a wide range of voltages.

# WAVEFORM ANALYZER



## FEATURES:

- A "flat top" characteristic as shown by the curve at right is obtained by use of the three-crystal filter. This feature makes tuning easier and increases the stability of the tuning adjustment.
- A very wide range of input voltages — 1,000,000 to 1, full scale — can be accommodated directly.
- Self-contained calibrating systems make it possible to standardize the voltage and frequency calibrations easily at any time.
- The input impedance is constant at 1 megohm, but a built-in 100,000-ohm potentiometer is provided as an alternate input system where absolute voltage levels need not be determined.
- External magnetic fields cause no trouble because the balanced modulator is fed by a

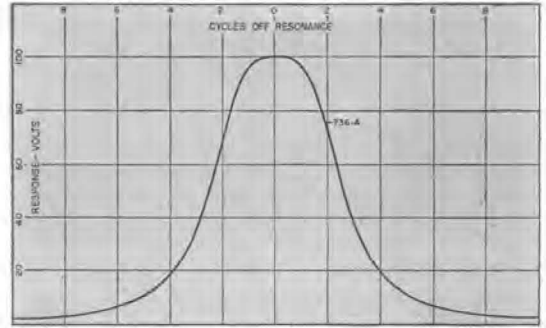

Transmission characteristic of the crystal filter in the Type 736-A Wave Analyzer.

- phase inverter tube, rather than by a transformer.
- Humidity effects are minimized by the hermetic sealing of all critical parts.

## SPECIFICATIONS

**Frequency Range:** 20 to 16,000 cps.

**Effective Bandwidth:** 4 cps.

**Selectivity:** Approximately as shown in plot, above. The response is down 15 db at 5 cps, 30 db at 10 cps, 60 db at 30 cps from the peak. The selectivity is constant over the frequency range.

**Voltage Range:** 300 microvolts to 300 volts full scale. The lowest division on the meter corresponds to 10  $\mu$ v. The over-all range is divided into four major ranges: 300  $\mu$ v to 300 mv, 3 mv to 3 v, 30 mv to 30 v, 0.3 to 300 v. Each of these ranges is divided into seven scale ranges; for example, the 0.3 v to 300 v range has the following full-scale ranges: 0.3 v, 1 v, 3 v, 10 v, 30 v, 100 v, 300 v.

A direct-reading decibel scale is also provided.

**Voltage Accuracy:** Within  $\pm 5\%$  on all ranges. Spurious voltages from higher-order modulation products introduced by the detector are suppressed by at least 70 db. Hum is suppressed by at least 75 db.

**Input Impedance:** One megohm when used for direct voltage measurements. When used with the input potentiometer it is approximately 100,000 ohms.

**Accuracy of Frequency Calibration:**  $\pm(2\% + 1 \text{ cps})$ .

**Tube Complement:** Six 6J7; two 6K6-G; one each, 6B8, 6C5, 6X5G, 6F5-G; three NE-48 neon lamps.

**Power Supply:** 105 to 125 (or 210 to 250) volts, 40 to 60 cps. A voltage stabilizing circuit is included. Power input is about 65 watts. Three-wire power cord.

**Accessories Supplied:** Spare neon lamps, spare fuses, one Type 274-NL Shielded Connector, and a Type CAP-22 Power Cord.

**Mounting:** Shielded oak cabinet.

**Dimensions:** Width 19 1/8, height 25 1/4, depth 11 inches (495 by 640 by 280 mm), over-all.

**Net Weight:** 87 pounds (40 kg).

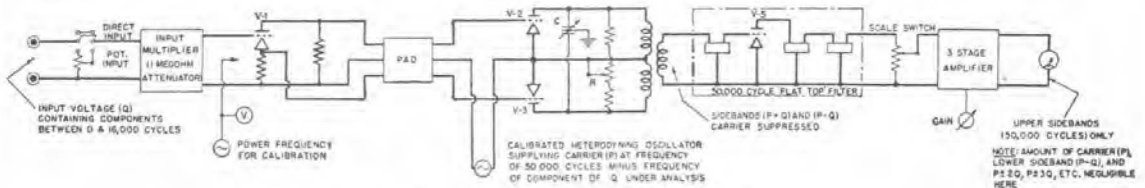

Schematic diagram of Type 736-A Wave Analyzer.

TYPE	CODE WORD	PRICE
736-A Wave Analyzer.....	ASKEW	\$1275.00

For other audio-frequency analyzers, see pages 189 and 227.



## TYPE 1932-A DISTORTION AND NOISE METER

**USES:** The TYPE 1932-A Distortion and Noise Meter measures distortion, noise, and hum level in audio-frequency circuits. In conjunction with the TYPE 1931-B Modulation Monitor, it can be used to measure these quantities directly in the output of radio broadcasting transmitters. It finds many uses in the electronics laboratory and in the production testing of radio receivers as a wide-range, highly sensitive voltmeter for such measurements as signal-to-noise ratio, AVC characteristics, and hum level. With the aid of an oscilloscope, individual hum and distortion components can be identified.

**DESCRIPTION:** The principal elements of the unit are a high-gain amplifier with an R-C interstage coupling unit that balances to a sharp null, a calibrated attenuator for adjusting the sensitivity, and a vacuum-tube voltmeter. Degeneration maintains stability in amplifier gain and a flat transmission characteristic, except within an octave of the null frequency. The null frequency is continuously variable. The null network eliminates the

fundamental of the audio-frequency signal, leaving only the distortion products, which are indicated directly on the panel meter.

The null network is switched out of the circuit for noise and hum measurements, and the instrument then operates as a highly sensitive voltmeter. Two input circuits are provided: (1) a transformer for bridging a 600-ohm line; and (2) a direct connection to the 100,000-ohm gain control.

### FEATURES:

- Continuous adjustment of frequency over the entire audio range is provided.
- Quick frequency selection.
- Frequencies up to 55,000 cps are passed by the amplifier circuits, so that distortion measurements can be made on fundamental frequencies up to 18,000 cps.
- Distortion as low as 0.1% can be measured.
- An auxiliary dbm calibration is provided.
- An oscilloscope connection is provided for visual observation of the noise or distortion components.

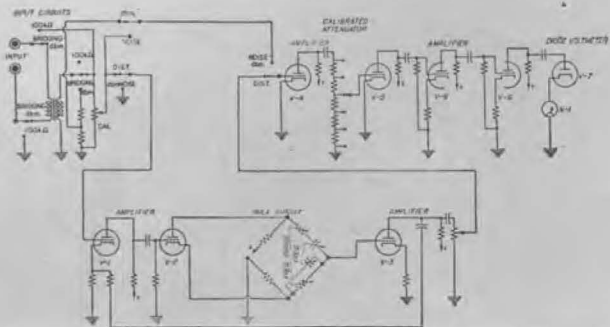

Functional schematic of the Type 1932-A Distortion and Noise Meter.



### SPECIFICATIONS

**Distortion Range:** Full-scale deflection for 0.3%, 1%, 3%, 10% or 30% distortion.

**Noise Measurement Range:** 80 db below reference calibration level, or 80 db below an audio-frequency signal of zero dbm level, at maximum sensitivity.

**Frequency Range**

**Distortion Measurements:** 50 to 18,000 cps fundamental; with bridging-transformer input, harmonics up to 30 kc; with 100,000-ohm input, harmonics up to 55 kc.

**Residual Distortion and Hum Level:**

50 to 150 cps, .07%. 150 to 5000 cps, .02%. 5000 to 18,000 cps, .10%.\*

\* Can be reduced to .02% by use of low-level calibration techniques.

**Accuracy:** Distortion  $\pm 5\%$  of full scale,  $\pm$  residual distortion. Noise-dbm,  $\pm 5\%$  of full scale for specified bandwidths, and with distortion defined as the ratio of harmonics-plus-noise to total input signal.

**Residual Noise Level:** At least 80 db down.

**Input Impedance:** 100,000 ohms, unbalanced, and 600-ohm bridging input (10,000 ohms), balanced or unbalanced.

**Meter:** A large meter with an illuminated scale is provided, calibrated in percentage and db. The ballistic characteristic is similar to that of a vu meter.

**Tube Complement:** Four 6J5-GT; two 0D3/VR150; one each 6SN7-GT, 6K6-GT, 6H6, 6X5-GT/G.

**Accessories Supplied:** TYPE CAP-22 Power Cord, cable for connecting to the TYPE 1931-B Modulation Monitor, spare fuses.

**Other Accessories Required:** For measuring the distortion in oscillators and other audio-frequency sources, no additional equipment is required. For measurements on amplifiers, lines, and other communications networks, a low-distortion oscillator is required. TYPE 1301-A Low-Distortion Oscillator (see page 98) is recommended. When the modulated output of a radio transmitter is to be measured, a linear demodulator is necessary. The TYPE 1931-B Modulation Monitor (page 132) is recommended. However, any detector system having minimum undistorted output of 1.5 volts rms can be used.

**Terminals:** Terminals are provided at the rear for connection to the modulation monitor. A Western Electric jack is provided at the panel also, as an auxiliary input circuit. Plugging into this jack automatically disconnects the rear connectors.

**Power Supply:** 105 to 125 (or 210 to 250) volts, 50 to 60 cps. The line input power is 65 watts. Three-wire cord (TYPE CAP-22) supplied.

**Mounting:** The instrument is relay-rack mounted. End frames are available for table mounting. (See price list below.)

**Panel Finishes:** Standard General Radio gray crackle. Certain standard finishes which can be processed in quantity can be supplied.

**Dimensions:** Width 19, height 7, depth 13 inches (485 by 180 by 330 mm) over-all; depth behind panel, 12 inches (305 mm).

**Net Weight:** 35½ lb (16 kg).

TYPE		CODE WORD	PRICE
1932-A	Distortion and Noise Meter.....	TABOO	\$725.00
FRI-412	Aluminum End Frames.....	ENDFRAMDIG	13.00 Pair

## TYPE 1932-P1 A-M DETECTOR UNIT



The TYPE 1932-P1 A-M Detector Unit, for measuring the a-m noise level in f-m transmitters, consists of a linear rectifier and an r-f filter, with provision for introducing an audio-frequency calibrating voltage. The detector output, after filtering, is passed through a standard 75-microsecond de-emphasis circuit to the Distortion and Noise Meter. The de-emphasis circuit can be switched out to give a flat characteristic, if desired. A microammeter indicates the diode current.

Provision is made for the use of an external diode detector to cover ranges of carrier frequency not included in the normal operating range of the self-contained diode detector.

### SPECIFICATIONS

**R-F Input:** 4 to 8 volts required, from low-impedance line, 50-220 Mc.

**Audio Input:** 400 cps; 4 to 8 volts; 1000-ohm input impedance.

**Audio Output:**

30-30,000 cps  $\pm 1$  db; or 75  $\mu$ sec de-emphasis characteristic.

1 to 1.5 volts, into 100 k $\Omega$  load.

**Diode:** 1N3J-A Crystal.

**Terminals:** Telephone jack for a-f voltage; coaxial connector for r-f voltage; plug for inserting into panel jacks of Distortion and Noise Meter; telephone jack for external diode detector.

**Accessories Supplied:** 1 TYPE S74-CS Cable Connector.

**Mounting:** Wrinkle-finish case, in gray.

**Dimensions:** 5½ by 6 by 2½ inches, (135 by 155 by 64 mm) over-all.

**Net Weight:** 1½ pounds (0.7 kg).

TYPE		CODE WORD	PRICE
1932-P1	A-M Detector Unit.....	AMDET	\$105.00



# PARTS AND ACCESSORIES



The General Radio Company has developed and is constantly improving a comprehensive line of parts for use in its laboratory and industrial instruments. Among the design objectives are maximum reliability, long life, convenience, attractive appearance, and known electrical characteristics. All General Radio parts are painstakingly designed, use the best available materials, and are produced by methods that yield reasonable prices. One important design consideration is to produce integrated groups of basic elements that fit together electrically and have a unity of appearance.

An excellent example of the integrated line is found in General Radio binding posts, coaxial elements, and plugs and jacks. The standard GR TYPE 274 Plug seats into the chamfered binding-post top to ensure mechanical and electrical stability. Insulators are keyed to the binding posts and may be keyed to the panel if desired. These insulators can also be used to mount the TYPE 938 Jack. Both the binding posts and jacks have tips for soldering — no lugs are used since they can introduce an uncertainty of contact.

The General Radio TYPE 874 Coaxial Connector, described on pages 38 and 40, has become an accepted laboratory standard for high-frequency work. Recent improvements in these connectors include a means of locking, greater mechanical stability, and greatly reduced leakage. The inner conductor of these connectors accepts a TYPE 274 Plug.

The TYPE 274-MB Double Plug is another connector that has become standard equipment in almost all laboratories. The springs of these plugs, as of all TYPE 274 plugs, are of hardened beryllium-copper for low contact resistance. The plugs are embedded, for

strength, into a styrene body. A cross hole provides strain relief for attached leads or cable. To reduce the chance of electrical shock, no metal part except the plugs themselves is exposed. For completely shielded connections to TYPE 938 Binding Posts, the TYPE 274-NK Shielded Double Plug is available. Patch cords are available which terminate in TYPE 274 double plugs, shielded double plugs, or single plugs on the cord and pigtail leads.

The TYPE 970 Potentiometers have been designed with particular care to produce an instrument-grade potentiometer at reasonable cost. Materials have been selected to produce a high degree of mechanical strength and stability coupled with correct electrical design.

The TYPES 1420 and 1421 Capacitors are made from solid shaped extruded aluminum stock, which yields advantages in stability and mechanical strength. The electric characteristics of these capacitors are equally good.

General Radio knobs are available in a variety of models and sizes and are consistent in style with the binding posts. Shaft holes are bored for precision, and all except the smallest are provided with two setscrews.

Dials are designed to close mechanical tolerances, and are available for direct drive, friction drive, and gear drive.

The TYPE 941 Transformer is a general-purpose impedance-matching transformer for general laboratory work at audio and ultrasonic frequencies.

The TYPE 578 Transformer is designed specifically for generator or detector isolation in ac bridge circuits, and has an effective interwinding capacitance of only 0.3 pf.

To comply with our minimum-billing requirements, a single order must total at least 10 dollars.

## CONTENTS

Binding Posts . . . . .	238
Capacitors . . . . .	230
for Laboratory Capacitors refer to pages 156 to 171	
Dials . . . . .	234
Knobs . . . . .	236
Patch Cords and Power Cords . . . . .	241
Plugs and Jacks . . . . .	240
for Coaxial Connectors refer to pages 38 to 55	
Potentiometers . . . . .	231
Transformers . . . . .	237





## VARIABLE AIR CAPACITORS

TYPE 1420 AND TYPE 1421



Type 1420



Type 1421

These capacitors were developed especially for use in laboratory instruments requiring low dielectric losses, low inductance and resistance, and high mechanical and thermal stability. The rotor and stator are each machined from solid, shaped aluminum extrusions of identical alloy. The illustration shows how the one-piece stator also serves as a frame for the assembly.

**FEATURES:**

- Low residual inductance and resistance.
- Good linearity.
- Low temperature coefficient.
- Insulated rotor.
- Sealed, long-life ball bearings.

**Capacitance Range:**

TYPE	NOMINAL		RANGE FOR LINEAR VARIATION.
	MAX	MIN	
1420-F	70	13	54 ± 5pf
1420-G	130	14	108 ± 5pf
1420-H	250	16	216 ± 5pf
1421-J	575	22	540 ± 20pf
1421-K	1120	29	1025 ± 25pf

**SPECIFICATIONS**

The rotor-to-ground capacitance is about 1pf for the Type 1420 and about 2.5pf for the Type 1421. The stator-to-ground capacitance is about 1.5pf for the Type 1420, and 4pf for Type 1421. The data in the above table are for the capacitor used as a two-terminal device, with rotor grounded. If the stator is grounded, maximum and minimum capacitance values will be decreased by about 1pf.

**Linearity:** The variation of capacitance with angle of rotation is guaranteed linear within ±0.3% of full scale. The angular range of linear variation is 1.0°.

Typical independent linearity is better than ±0.2%.

**Dielectric Losses:** For the grounded-rotor connection, the dielectric losses correspond to a  $D_0C_0$  product of less than  $.01 \times 10^{-12}$ . The rotor-to-ground capacitance has a  $D_0C_0$  product of  $0.1 \times 10^{-12}$ . This loss component is in parallel with the main capacitance only for the grounded-stator connection.

**Inductance:** Approximately .006  $\mu$ h

**Insulation Resistance:** Greater than  $10^{11}$  ohms under standard ASTM laboratory conditions (23 C, 50% RH).

**Temperature Coefficient of Capacitance:** Approximately +0.003% per degree C.

**Shock and Vibration:** The Type 1420 Capacitors will pass shock and vibration tests of MIL-T-915-A.

**Maximum Voltage:** 700 volts peak.

**Torque:** 2 ounce-inches maximum with shaft vertical.

**Net Weight:** Type 1420-F, 4 oz (110g); Type 1420-G, 4 1/2 oz (125 g); Type 1420-H, 5 1/2 oz (155 g); Type 1421-J, 1 lb 8 oz (370 g); Type 1421-K, 1 lb 11 oz (810 g).

**Dimensions:** See sketches below. To convert inches to mm, multiply by 25.4. Where dimensions are critical write for a copy of the latest drawings.

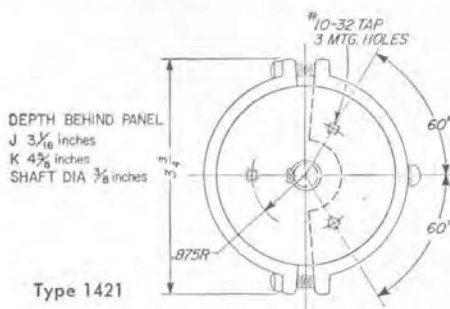
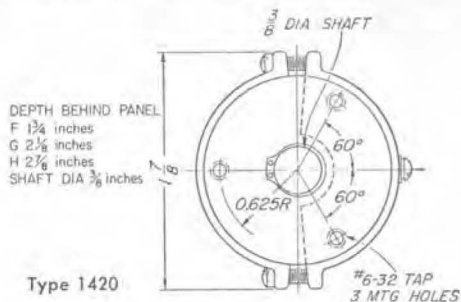

TYPE		CODE WORD	PRICE
1420-F	70 pf, max.	MARRY	\$30.00
1420-G	130 pf, max.	MATIN	32.00
1420-H	250 pf, max.	MAXIM	33.00
1421-J	575 pf, max.	NABIR	55.00
1421-K	1120 pf, max.	NABOB	58.00

See pages 234 and 236 for knobs and dials for use with these capacitors.





## 970-SERIES POTENTIOMETERS

The 970-Series Potentiometers are moderately priced, high-quality controls with performance approaching the best available. They can be used not only at dc, but also throughout the audio- and ultrasonic-frequency ranges and, in many applications, at low radio frequencies.

**DESCRIPTION:** The materials used in the all-phenolic body (1), dust-proof cover (2), and glass-reinforced-polyester shaft (3) minimize the capacitance to ground. Low inductance results from the use of a thin winding form of phenolic laminate. A small-diameter brush (4) of precious-metal alloy assures high resolution. Brush arm and spring (5) are combined into a single stamping of spring-temper phosphor-bronze. The screw (6) that holds the cover to the base passes through a horse-hoe-shaped slot in the brush arm to serve as a rotational stop that exerts no force on the brush. The brush rides with uniform pressure on the firmly anchored wires at the edge of the resistance winding (7). The combination of precious-metal contact, firm clean track, and uniform contact pressure minimizes electrical noise.

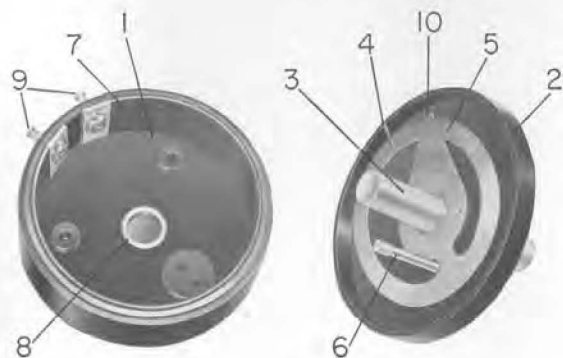

The projecting hub (11) permits adjustment of the shaft with respect to the contact brush while the case is closed. This hub rotates in a reamed brass insert molded into the cover to form a metal-to-metal main bearing close to the plane of the brush. The shaft is rigidly held by this hub, and a second bearing is provided by a stainless-steel insert (8) to guide the shaft in the base. This arrangement provides stable, repeatable settings.

Resistance elements are wound of low-temperature-coefficient alloys. Linearity is assured by uniform turn spacing, on a mandrel that is firmly cemented into the cylindrical base molding.

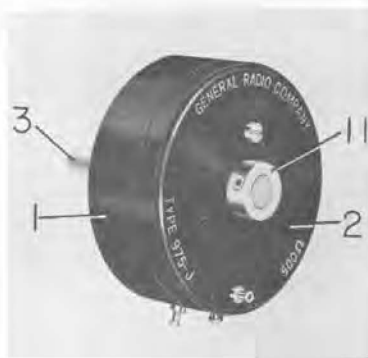

The turret terminals (9) are both riveted to the end clamps and soldered to the ends of the winding (7) and to the silver-plated spring-bronze contact take-off in the cover (10), so that none of the fixed internal connections depends upon pressure alone.

### SPECIAL TYPES

Units in the 970 design can be made on special order with: 360° mechanical rotation, taps as close as  $\frac{1}{4}$  inch apart along the entire winding, resistance other than listed values, resistance tapers, resistance tolerance and linearity tolerances better than standard. For applications requiring maximum shaft rigidity, shafts of metal-cored phenolic or of metal can be supplied.

### GANGING

When ganged, the 970-Series Potentiometers retain their low-capacitance characteristics. Units are designed to be nested with phenolic spacing rings stacked on a long shaft, and held together with thin metal clamping rings and tie rods. This assembly allows units to be set in any desired phase relationship. Inquiries are welcomed on a special-design basis.



### KNOBS

Recommended knobs for these potentiometers are described on page 236. Use TYPES KNS-6 and KNPS-6 for TYPES 971, 972, 973, and 974; TYPES KNS-8 and KNPS-8 for TYPES 975 and 976; and TYPES KNS-12 and KNPS-12 for TYPES 977 and 978.



# PARTS

## POTENTIOMETERS



TYPE 971					TYPE 972					TYPE 973					TYPE 974					
WHERE DIMENSIONS ARE CRITICAL WRITE FOR A COPY OF LATEST DRAWINGS.																				
APPROXIMATE WEIGHT 1/2 OZ. EFFECTIVE ELECTRICAL ROTATION 315 ±5° TOTAL MECHANICAL ROTATION 330 ±5° STANDARD RESISTANCE TOLERANCE ±5% AVERAGE TORQUE 1 3/4 OZ IN					APPROXIMATE WEIGHT 3/4 OZ. EFFECTIVE ELECTRICAL ROTATION 315 ±5° TOTAL MECHANICAL ROTATION 330 ±5° STANDARD RESISTANCE TOLERANCE ±5% AVERAGE TORQUE 1 3/4 OZ IN					APPROXIMATE WEIGHT 1 OZ. EFFECTIVE ELECTRICAL ROTATION 320 ±5° TOTAL MECHANICAL ROTATION 330 ±5° STANDARD RESISTANCE TOLERANCE ±5% AVERAGE TORQUE 2 1/2 OZ IN					APPROXIMATE WEIGHT 1 3/4 OZ. EFFECTIVE ELECTRICAL ROTATION 320 ±5° TOTAL MECHANICAL ROTATION 330 ±5° STANDARD RESISTANCE TOLERANCE ±5% AVERAGE TORQUE 2 1/2 OZ IN					
TYPE LETTER	NOMINAL RESISTANCE OHMS	TEMPERATURE COEFFICIENT OF RESISTANCE	RESOLUTION	INDEPENDENT LINEARITY	TYPE LETTER	NOMINAL RESISTANCE OHMS	TEMPERATURE COEFFICIENT OF RESISTANCE	RESOLUTION	INDEPENDENT LINEARITY	TYPE LETTER	NOMINAL RESISTANCE OHMS	TEMPERATURE COEFFICIENT OF RESISTANCE	RESOLUTION	INDEPENDENT LINEARITY	TYPE LETTER	NOMINAL RESISTANCE OHMS	TEMPERATURE COEFFICIENT OF RESISTANCE	RESOLUTION	INDEPENDENT LINEARITY	
B	2	+0.07%																		
C	5		<1%							C	5	+0.07%								
D	10									D	10									
E	20									E	20	+0.07%								
F	50					F	50	<1%		F	50		<0.5%							
G	100	±0.002%				G	100			G	100									
H	200		<0.5%	±2%		H	200	±0.002%		H	200		±0.002%							
J	500					J	500		<0.5%	±2%	J	500								
K	1000					K	1000				K	1000								±1%
L	2000					L	2000				L	2000		<0.2%						
M	5000	±0.002%				M	5000				M	5000								<0.2%
N	10,000		<0.2%			N	10,000	±0.002%			N	10,000	±0.002%							
P	20,000					P	20,000		<0.2%		P	20,000								±1%
Q	50,000					Q	50,000				Q	50,000								
R	100,000																			

TYPE	CODE WORD	PRICE	TYPE	CODE WORD	PRICE	TYPE	CODE WORD	PRICE	TYPE	CODE WORD	PRICE
971-B	ANTRIMBITE	\$4.50	972-F	BANTERFALL	\$4.50	973-C	CANDIDCREW	\$4.75	974-D	DANCERDULL	\$5.25
971-C	ANTRIMCREW	4.50	972-G	BANTERGERM	4.50	973-D	CANDIDDULL	4.75	974-E	DANCEREARL	5.25
971-D	ANTRIMDULL	4.50	972-H	BANTERHUNT	4.50	973-E	CANDIDEARL	4.75	974-F	DANCERFALL	5.25
971-E	ANTRIMEARL	4.50	972-J	BANTERJUMP	4.50	973-F	CANDIDFALL	4.75	974-G	DANCERGERM	5.25
971-F	ANTRIMFALL	4.50	972-K	BANTERKISS	4.50	973-G	CANDIDGERM	4.75	974-H	DANCERHUNT	5.25
971-G	ANTRIMGERM	4.00	972-L	BANTERLEAP	4.50	973-H	CANDIDHUNT	4.75	974-J	DANCERJUMP	5.25
971-H	ANTRIMHUNT	4.00	972-M	BANTERMILK	4.50	973-I	CANDIDJUMP	4.75	974-K	DANCERKISS	5.25
971-J	ANTRIMJUMP	4.00	972-N	BANTERNULL	4.50	973-K	CANDIDKISS	4.75	974-L	DANCERLEAP	5.25
971-K	ANTRIMKISS	4.00	972-P	BANTERPARK	4.50	973-L	CANDIDLEAP	4.75	974-M	DANCERMILK	5.25
971-L	ANTRIMLEAP	4.00	972-Q	BANTERQUAD	4.50	973-M	CANDIDMILK	4.75	974-N	DANCERNULL	5.25
971-M	ANTRIMMILK	4.00				973-N	CANDIDNULL	4.75	974-P	DANCERPARK	5.25
971-N	ANTRIMNULL	4.00				973-P	CANDIDPARK	4.75	974-Q	DANCERQUAD	5.25
971-P	ANTRIMPARK	4.00				973-Q	CANDIDQUAD	4.75	974-R	DANCERRISK	5.25





# PARTS POTENTIOMETERS

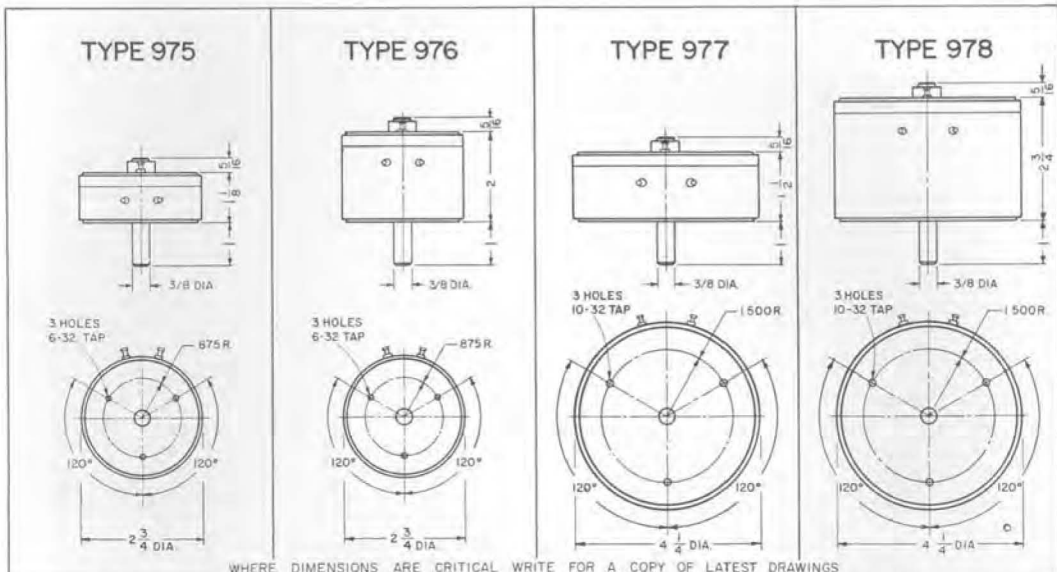

WHERE DIMENSIONS ARE CRITICAL WRITE FOR A COPY OF LATEST DRAWINGS

APPROXIMATE WEIGHT	3 OZ.	APPROXIMATE WEIGHT	4 OZ.	APPROXIMATE WEIGHT	9 OZ.	APPROXIMATE WEIGHT	12 OZ.
EFFECTIVE ELECTRICAL ROTATION	320°±2°	EFFECTIVE ELECTRICAL ROTATION	320°±2°	EFFECTIVE ELECTRICAL ROTATION	320°±2°	EFFECTIVE ELECTRICAL ROTATION	320°±2°
TOTAL MECHANICAL ROTATION	330°±5°	TOTAL MECHANICAL ROTATION	330°±5°	TOTAL MECHANICAL ROTATION	330°±5°	TOTAL MECHANICAL ROTATION	330°±5°
STANDARD RESISTANCE TOLERANCE	±2%	STANDARD RESISTANCE TOLERANCE	±2%	STANDARD RESISTANCE TOLERANCE	±2%	STANDARD RESISTANCE TOLERANCE	±2%
AVERAGE TORQUE	4 OZ. IN.	AVERAGE TORQUE	4 OZ. IN.	AVERAGE TORQUE	6 OZ. IN.	AVERAGE TORQUE	6 OZ. IN.

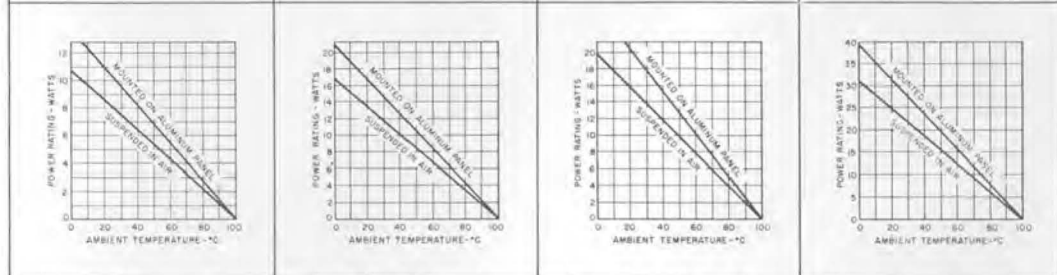

TYPE LETTER	NOMINAL RESISTANCE OHMS	TEMPERATURE COEFFICIENT OF RESISTANCE	RESOLUTION	INDEPENDENT LINEARITY	TYPE LETTER	NOMINAL RESISTANCE OHMS	TEMPERATURE COEFFICIENT OF RESISTANCE	RESOLUTION	INDEPENDENT LINEARITY	TYPE LETTER	NOMINAL RESISTANCE OHMS	TEMPERATURE COEFFICIENT OF RESISTANCE	RESOLUTION	INDEPENDENT LINEARITY	TYPE LETTER	NOMINAL RESISTANCE OHMS	TEMPERATURE COEFFICIENT OF RESISTANCE	RESOLUTION	INDEPENDENT LINEARITY	
J	500																			
K	1000	±0.002%	<0.2%		K	1000				*K	1000									
L	2000				L	2000	±0.002%	<0.2%		*L	2000	±0.002%	<0.1%		*L	2000				
M	5000				M	5000			±0.5%	*M	5000			±0.3%	*M	5000	±0.002%			
N	10,000				N	10,000				*N	10,000				*N	10,000		<0.1%		
P	20,000	±0.002%	<0.1%		P	20,000				*P	20,000				*P	20,000				
Q	50,000				Q	50,000	±0.002%	<0.1%		*Q	50,000	±0.002%			*Q	50,000				
R	100,000		<0.05%		R	100,000				*R	100,000		<0.05%		*R	100,000	±0.002%			±0.3%
					T	200,000		<0.05%		*T	200,000				*T	200,000		<0.05%		
										*U	500,000									

TYPE	CODE WORD	PRICE	TYPE	CODE WORD	PRICE
975-J	EAGLETJUMP	\$5.25	976-K	FANGELKISS	\$6.00
975-K	EAGLETKISS	5.25	976-L	FENGELLEAP	6.00
975-L	EAGLELEAP	5.25	976-M	FANGELMILK	6.00
975-M	EAGLEMILK	5.25	976-N	FANGELNULL	6.50
975-N	EAGLENULL	5.75	976-P	FANGELPARK	6.50
975-P	EAGLEPARK	5.75	976-Q	FANGELQUAD	6.50
975-Q	EAGLETRISQUAD	5.75	976-R	FANGELRISK	6.50
975-R	EAGLETRISK	5.75	976-T	FANGELTICK	7.00

## DIAL PLATES

The TYPE 970-P1 (right) is a 2-inch dial plate for use with the TYPES 971, 972, 973, and 974 with a pointer-type knob. Scale covers 315°. The TYPE 970-P2 is a 2 3/4-inch reversible dial plate for use with the TYPE 975 and 976 with a pointer-type knob or attached to a knob. Scale covers 320°.



TYPE	CODE WORD	PRICE
970-P1	DIPAL	\$0.55
970-P2	DIPOTI	.55

\* Types 977 and 978 are not usually stocked but can be manufactured on special order. Inquiries are invited.



Type 907-WB



Type 907-WA

## GEAR-DRIVE PRECISION DIALS

The TYPES 907 and 908 Gear-Drive Precision Dials have aluminum dial plates with black enamel finish. Scales are individually engraved on an automatic, self-indexing engraving machine. The fine, radial, accurately located lines divide the complete circumference into 360 divisions numbered from 0 to 360.

Settings can be consistently duplicated to one-fifth of a division, allowing a precision of resetting of better than 0.06% of full scale. Parallax is eliminated by the use of an indicator that always remains flush with the surface of the dial, and which at the same time absorbs, through the flexibility of its mounting, any slight eccentricities of the main shaft.

The ring gear and drive pinion are precision-cut gears, spring pressed to eliminate any backlash. The drive ratio is 10:1, and it is possible to use a calibrated vernier or increment dial on the pinion shaft if desired. The drive pinion is held in a stainless-steel collet, which runs in a phosphor-bronze bushing. The collet allows the drive to be adjusted for any panel thickness up to  $\frac{5}{16}$  inch.

The main dials are set permanently and securely to their shafts through the use of two setscrews 90° apart; this procedure eliminates any dial backlash that might otherwise occur. The dial hubs are bored to receive a  $\frac{3}{8}$ -inch shaft, but a bushing is furnished for use with  $\frac{1}{4}$ -inch shafts.

The dial indicator, knob, and all necessary mounting parts are supplied, as are complete drilling and mounting instructions.

**MOTOR DRIVES**— Motor drives for attachment to these dials are described on page 146.

Motor drive attached to a 908-type dial on the Type 1304-B Beat-Frequency Audio Generator.



TYPE	MOUNTING	DIAL		MAX. PANEL THICKNESS	TOTAL PANEL AREA*	NET WEIGHT*	CODE WORD	PRICE
		ARC	DIVISIONS					
<b>4-INCH DIAMETER GEAR-DRIVE PRECISION DIALS</b>								
907-WA	Front-of-Panel	360°	360	—	4 × 5 inches	11 oz	DITAB	\$10.50
907-WB	Back-of-Panel	360°	360	$\frac{5}{16}$ inch	4 × 5 inches	11 oz	DITOP	10.50
<b>6-INCH DIAMETER GEAR-DRIVE PRECISION DIALS</b>								
908-WA	Front-of-Panel	360°	360	—	6 × 7½ inches	21 oz	DIVAT	\$15.50
908-WB	Back-of-Panel	360°	360	$\frac{5}{16}$ inch	6 × 7½ inches	19 oz	DIVIM	15.50

PATENT NOTICE. See Note 13, page viii.

\* To convert in. to mm, multiply by 25.4. To convert oz to g, multiply by 28.



Type 904-VF



Type 902-TF



Type 901-WD

Approx  
1/2 size

## FRICION-DRIVE AND DIRECT-DRIVE DIALS

These dials are attractive in appearance, with accurate, photo-etched scales. The dial plates are of aluminum, with black enamel finish. These dials are intended for applications where precisely cut scales and precision drives are not necessary.

The friction-drive mechanism, which is available on the 2<sup>3</sup>/<sub>4</sub>-inch (TYPE 902) and 4-inch (TYPE 904) sizes, consists of a thin disk which is mounted on the back of the dial plate, gripped and driven by two small disks attached to the friction-drive shaft. The tension of the drive can be easily adjusted after installation of the dial.

The dials are insulated from the shaft. Knobs are secured to their shafts by the use of two setscrews separated by 90°. These knobs are supplied bored to receive a 3/8-inch shaft. Bushings are supplied for use on 1/4-inch shafts.

The indicators shown in the photographs above are designed to remain flush with the surface of the dial as the dial is rotated. This eliminates parallax and absorbs any slight eccentricities of the main shaft.

Indicators, mounting screws, drive knobs, and drilling templates are furnished with the dials.

TYPE	DIAL		DRIVE	NET WEIGHT *	CODE WORD	PRICE
	ARC	DIVISIONS				
<b>2-INCH DIAMETER — TYPE 901 DIALS</b>						
901-TD	180°	100	Direct	2 oz	DIALOG	\$2.60
901-VD	270°	100	Direct	2 oz	DILAP	2.60
901-WD	360°	100	Direct	2 oz	DILID	2.60
<b>2<sup>3</sup>/<sub>4</sub>-INCH DIAMETER — TYPE 902 DIALS</b>						
902-TD	180°	100	Direct	2 1/2 oz	DIMAP	\$2.75
902-VD	270°	100	Direct	2 1/2 oz	DIMID	2.75
902-TF	180°	100	Friction, 3.3:1	4 oz	DIMOB	4.75
902-VF	270°	100	Friction, 3.3:1	4 oz	DIMUG	4.75
<b>4-INCH DIAMETER — TYPE 904 DIALS</b>						
904-TF	180°	100	Friction, 5:1	8 oz	DIPEN	\$6.00
904-VF	270°	200	Friction, 5:1	8 oz	DIPUT	6.00

PATENT NOTICE. See Note 13, page viii.

\*To convert oz to g, multiply by 28.





## TYPE KN FLUTED KNOBS

These black phenolic knobs are similar to those used on General Radio laboratory instruments. Each is molded with a brass insert bored for a  $\frac{3}{8}$ -inch shaft except the TYPE KN5P-1, which is bored for a  $\frac{1}{4}$ -inch shaft. The knob is clamped to the shaft by two set-

screws spaced  $90^\circ$  apart except in TYPES KN5P-6 and KNS-6, which have  $135^\circ$  spacing. TYPE KNB-1 has a single setscrew. TYPES KNS(P)-8, -10, and -12 have molded holes which can be drilled deeper to allow a dial plate to be attached to the knob.

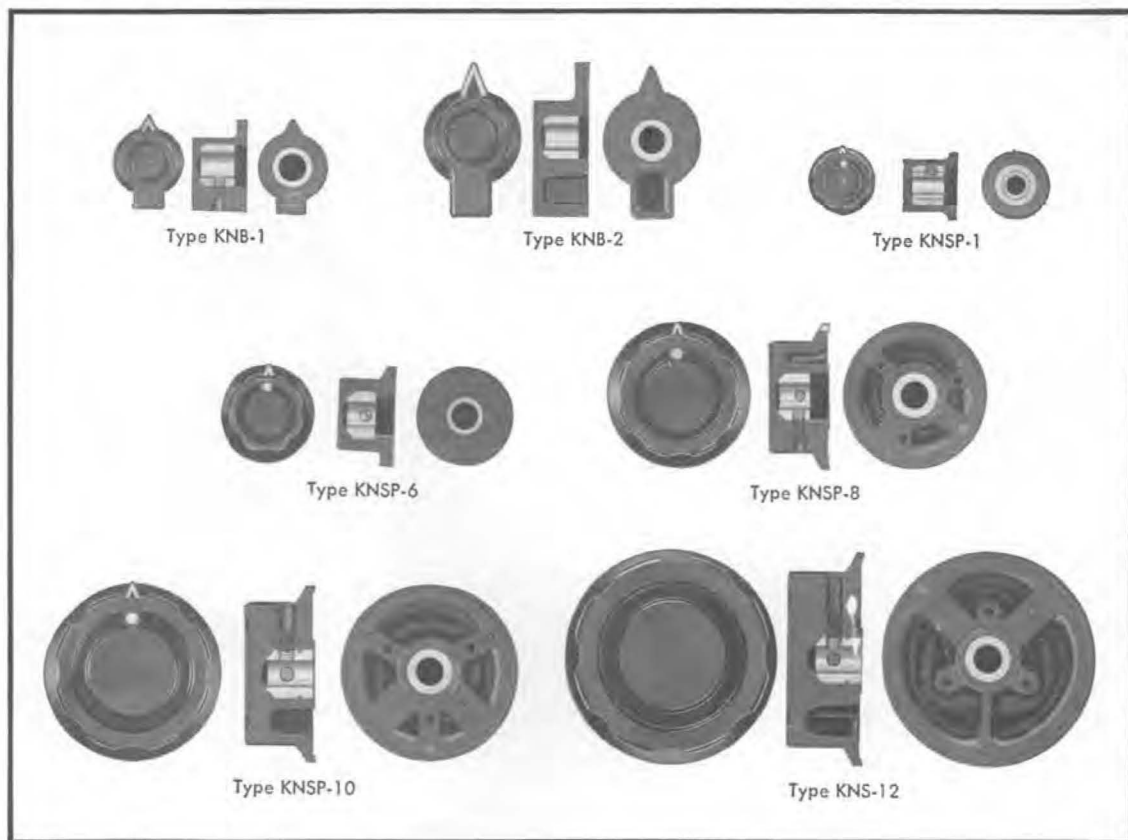

TYPE	SKIRT DIA., IN INCHES‡		NET WT FOR 5, IN OUNCES§	CODE WORD	UNIT PRICE† IN LOTS OF				
					5*-19	20-199	200-399	400-1999	2000 UP
KNB-1	1 $\frac{5}{16}$	Bar Type	3 $\frac{3}{4}$	BARKNOBONE	\$0.80	\$0.70	\$0.65	\$0.60	\$0.57
KNB-2	1 $\frac{5}{16}$	Bar Type	6	BARKNOBTWO	0.85	0.74	0.69	0.63	0.60
KN5P-1	1 $\frac{3}{16}$	With Pointer	6	NURLNOBDEN	0.60	0.52	0.48	0.44	0.42
KN5P-6	1 $\frac{5}{16}$	With Pointer	5 $\frac{1}{2}$	NURLNOBSIX	0.60	0.52	0.48	0.44	0.42
KNS-6	1 $\frac{5}{16}$	Without Pointer	5 $\frac{1}{2}$	NURLNOBOUT	0.60	0.52	0.48	0.44	0.42
KN5P-8	1 $\frac{1}{2}$	With Pointer	8	NURLNOBATE	0.70	0.62	0.58	0.54	0.52
KNS-8	1 $\frac{1}{2}$	Without Pointer	8	NURLNOBOAF	0.70	0.62	0.58	0.54	0.52
KN5P-10	2 $\frac{1}{4}$	With Pointer	12 $\frac{1}{2}$	NURLNOBTEN	1.05	0.92	0.86	0.78	0.75
KNS-10	2 $\frac{1}{4}$	Without Pointer	12 $\frac{1}{2}$	NURLNOBORB	1.05	0.92	0.86	0.78	0.75
KN5P-12	2 $\frac{7}{8}$	With Pointer	17	NURLNOBGIG	1.25	1.12	1.06	0.98	0.95
KNS-12	2 $\frac{7}{8}$	Without Pointer	17	NURLNOBDOZ	1.25	1.12	1.06	0.98	0.95

PATENT NOTICE. See Note 13, page viii.

§To convert oz to g, multiply by 28.

‡To convert in. to mm, multiply by 25.4.

†Net. No further quantity discounts.

\*Minimum quantity sold.



### TYPE 578 SHIELDED TRANSFORMER

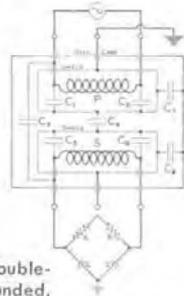

Grounded bridge supplied through a double-shielded transformer. When case is grounded, the capacitance placed across each capacitance arm is 40 pf. Note that the winding shield on the bridge side is not grounded, but is floating.

This transformer is used in direct-reading ac bridges to isolate the bridge circuit from changes in electrostatic potential in the generator (or detector) circuit and to reduce the effect of the capacitance of the external circuit to ground. It can also be used to isolate any measuring circuit from the generator or detector, or to produce a balanced output from a grounded generator.

Three shields are used, one around each winding and a third to bring the core laminations to the potential of the case.

#### SPECIFICATIONS

**Turns Ratio:** 4 to 1 or 1 to 4.

**Ranges:** See price table.

**Nominal Capacitances:** See drawing.

$C_1, C_2, C_5, C_6$ .....each 200 pf  
 $C_3$ .....0.3 pf  
 $C_7, C_8$ .....each 70 pf  
 $C_4$ .....30 pf

**Winding Inductance:** Turns squared (see table) multiplied by  $3.5 \times 10^{-8}$  henry, approx.

**Dc Resistance:** (In ohms) 30 times inductance in henrys, approx.

**Voltage Limits:** The high-impedance winding of Types 578-A or -B may be connected directly across a 115-volt 50- to 60-cycle line if the impedance connected to the other winding equals or exceeds the lowest value given under "low impedance" in the table below. The Type 578-B may be used at 25 cps under the same conditions.

For Types 578-A or -B, the low-impedance winding may be connected directly to a 115-volt, 50- to 60-cycle line provided that the resistance across the high-impedance winding exceeds 10,000 ohms. The Type 578-B may be used at 25 cps under the same conditions.

**Insulation:** The insulation from winding to winding and from windings to case will withstand 1000 volts, peak.

**Dimensions:** Base,  $3\frac{1}{8} \times 2\frac{3}{16}$  inches (80 by 70 mm); height,  $4\frac{1}{8}$  inches (105 mm).

**Net Weight:**  $2\frac{1}{2}$  pounds (1.2 kg).

### TYPE 941-A TOROIDAL TRANSFORMER



#### FOR IMPEDANCE MATCHING OR BRIDGING IN LOW-LEVEL 600-OHM COMMUNICATION CIRCUITS

This transformer has highly astatic windings and tight coupling. The toroidal core is a spiral of high-permeability-alloy tape. Identical pairs of windings on each half of the toroid minimize pickup and induction field, while close coupling between inner and outer windings keeps leakage reactance low and extends high-frequency response.

#### SPECIFICATIONS

##### Frequency and Impedance Ranges:

TERMINATING IMPEDANCES	FREQUENCY FOR 1-DB DROP	FLAT INSERTION LOSS LESS THAN	
600Ω	9600Ω	80 cps—100 kc	0.3 db
600Ω	2400Ω	20 cps—135 kc	0.2 db
600Ω	2400Ω	80 cps—240 kc	0.2 db
600Ω	600Ω	20 cps—200 kc	0.1 db
150Ω	600Ω	5 cps—50 kc	0.7 db
150Ω	600Ω	20 cps—200 kc	0.2 db
37.5Ω	600Ω	5 cps—50 kc	0.8 db

**Zero-Signal Inductance:** Inner windings, in series, at least 5 henrys; outer windings, in series, at least 20 henrys.

**Voltage Matching:** Inner windings, 0.015% or better; outer windings, 0.08% or better.

**Operating Level and Distortion:**

WATTS	DBM	RMS DISTORTION, 60 CPS
1.26	31	<1%
1	30	<0.5%
0.5	27	<0.2%
0.032	15	<0.1%

**Resistance:** Inner windings, in series, 9 ohms; outer windings, in series, 34 ohms (approximately).

**Dimensions:** Aluminum case,  $3\frac{5}{8}$  by  $3\frac{1}{8}$  by  $1\frac{5}{8}$  inches (95 by 80 by 40 mm). Mounting blocks project  $\frac{3}{16}$  inch beyond case in  $3\frac{1}{8}$ -inch dimension. Mounting holes are  $3\frac{3}{8}$  inches on centers and are drilled for clearance with 10-32 machine screws.

**Net Weight:**  $13\frac{1}{2}$  ounces (380 g).

TYPE	CODE WORD	PRICE
941-A	TRANTORCAT	\$45.00

##### IMPEDANCE RANGE\*

TYPE	TURNS	FREQUENCY RANGE*	LOW-IMPEDANCE WINDING	HIGH-IMPEDANCE WINDING	CODE WORD	PRICE
578-A	600 to 2400	50 cps to 10 kc	50Ω to 5 kΩ	1 kΩ to 100 kΩ	TABLE	\$30.00
578-B	1000 to 4000	20 cps to 5 kc	60Ω to 6 kΩ	1.2 kΩ to 120 kΩ	TENOR	30.00
578-C	60 to 240	2 kc to 500 kc	20Ω to 2 kΩ	0.4 kΩ to 40 kΩ	TEPID	30.00

\*These ranges are for transmission within 6 db. At extremes of both impedance and frequency ranges, the transmission may be down by 12 db.





### TYPE 938 BINDING POST

WITH THE ELECTRICAL AND MECHANICAL PROPERTIES NEEDED FOR MODERN ELECTRONIC INSTRUMENTS

The TYPE 938 Binding Post combines excellent electrical properties and ingenious mechanical design. Materials are carefully chosen for their electrical and mechanical properties — brass with Bright-Alloy plate for high conductivity, and styrene insulation for high resistance and low power factor, either red or black for color coding.

It can be mounted on metal or insulating panels, of a thickness from zero to  $\frac{5}{16}$  inch. Mechanical details and methods of connection are shown below.

The binding post has the same height above panel as the TYPE 874 Coaxial Connector (see page 40), whose center will take a TYPE 274 Plug, so that a grounded binding post can be mounted adjacent to the coaxial connector to fit a TYPE 274-MB Double Plug.

PATENT NOTICE. See Note 3, page viii.

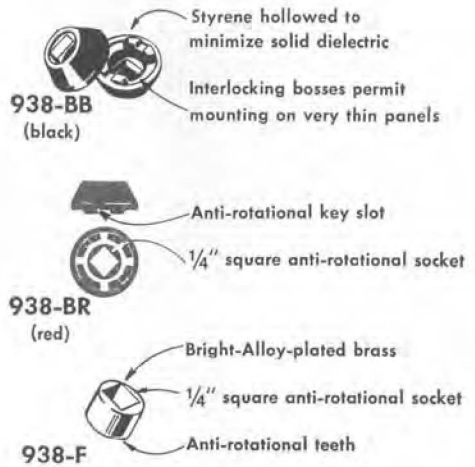
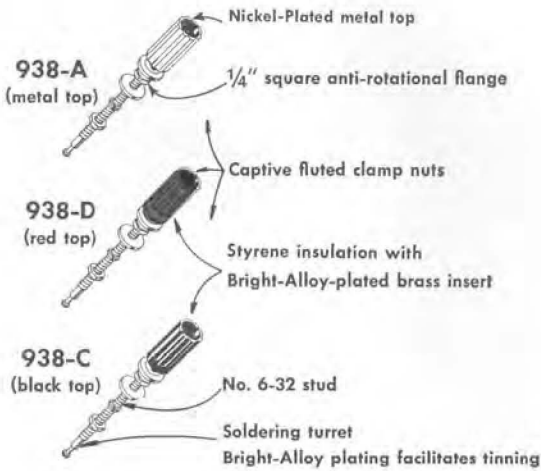

#### METHODS OF CONNECTION

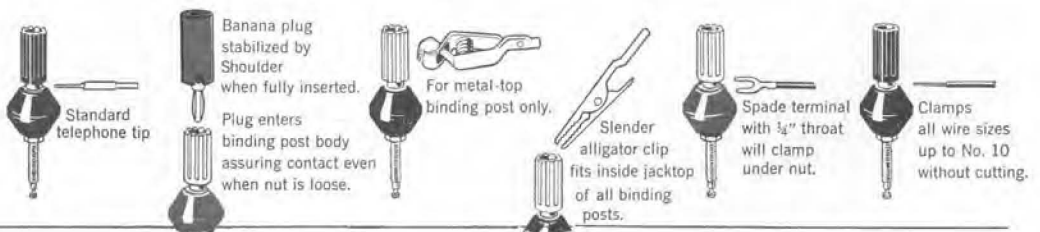





MECHANICAL DETAILS

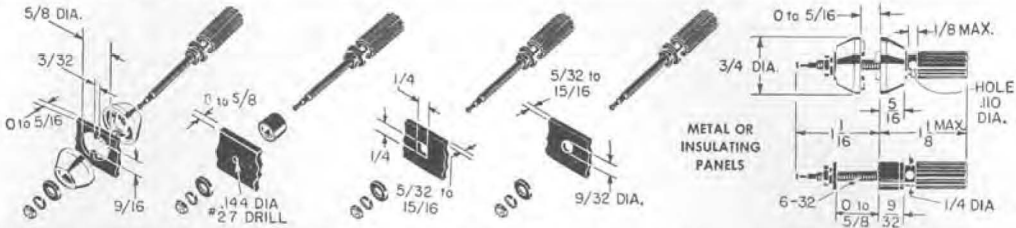

Locking keys in 5/8-inch mounting holes can be omitted if only moderate resistance to rotation is desired.

To convert inches to mm, multiply by 25.4.

TYPE 983 BINDING POST ASSEMBLIES

- 938-A + 938-F = 938-P
- 938-A + 938-BR = 938-R
- 938-A + 938-BB = 938-W
- 938-C + 938-BB = 938-WB
- 938-D + 938-BR = 938-WR
- 938-J + 938-BB = 938-XB\*
- 938-J + 938-BR = 938-XR\*

\*The Jack and Jack Assemblies are listed on page 240.

TYPE 938-L SHORTING LINK

Captive link for rapidly connecting or disconnecting binding posts mounted on 3/4" centers.



TYPE 838-B ALLIGATOR CLIP

Slender-nose clip that fits inside jack top of all TYPE 938 Binding Posts.



TYPE 938-YB INSULATORS

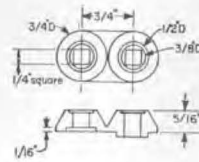

These insulators mount two binding posts, and are particularly easy to assemble, since 3/4-inch spacing is maintained without exact machining. Mount in 1/2" dia holes.

TYPE	DESCRIPTION	CODE WORD	UNIT PRICES † 10*-99	100- 999	1000- 1999	2000- up
<b>BINDING POSTS</b>						
938-A	Metal-Top Binding Post	STANPARASP	\$0.40	\$0.29	\$0.27	\$0.25
938-C	Black-Top Binding Post	STANPARAWL	.50	.35	.33	.30
938-D	Red-Top Binding Post	STANPARARM	.50	.35	.33	.30
<b>INSULATORS</b>						
938-BB	Black Insulators (Pair)	STANPARAUK	.20	.12	.11	.10
938-BR	Red Insulators (Pair)	STANPARATE	.20	.12	.11	.10
938-YB	Insulator (Pair)	STANPARPAN	.20	.18	.16	.15
<b>ACCESSORIES</b>						
938-F	Spacer	STANPARBON	.10	.07	.07	.07
838-B	Alligator Clip	STANPARNIP	.20	.19	.18	.17
938-L	Shorting Link	STANPARBET	.10	.09	.09	.09
<b>BINDING POST ASSEMBLIES</b>						
938-P	Metal top, 938-F Spacer	STANPARDOT	.50	.36	.34	.32
938-R	Metal Top, red Insulators	STANPARGIG	.60	.41	.38	.35
938-W	Metal Top, black Insulators	STANPARANT	.60	.41	.38	.35
938-WB	Black top and black Insulators	STANPARBAN	.70	.47	.44	.40
938-WR	Red top and red Insulators	STANPARCUB	.70	.47	.44	.40

PATENT NOTICE. See Note 3, page viii.  
 \*Minimum quantity sold.  
 †Net prices. No further quantity discounts.

add 10¢ per binding post for assembly, 8¢ for packaging.



### PLUGS AND JACKS

**TYPE 274 PLUGS AND JACKS**, originated by General Radio in 1924, are widely used in electronics and communications laboratories for connecting equipment in temporary or semi-permanent setups and for connecting plug-in elements. All TYPE 274 Plugs and Jacks are rated at 15 amperes. Plugs have nickel-plated brass studs and beryllium-copper springs. Jacks are nickel-plated brass. These plugs and

jacks are designed for positive and reliable contact, typically 1 milliohm. The plug seats firmly in the jack so that the plug springs are not depended upon for mechanical stability.

**TYPE 938 JACKS** also fit TYPE 274 Plugs. The TYPE 938-J Jack has a longer shank than the TYPE 274 Jack. The TYPE 938-X Jack Assembly consists of the TYPE 938-J Jack and TYPE 938-BB Insulators (page 238).

TYPE	CODE WORD	UNIT PRICE† IN LOTS OF				
		10* 99	20* 99	100- 999	1000- 1999	2000 up
274-P Fits 274-J	STANPARCAT		\$0.13	\$0.11	\$0.10	\$0.09
274-U Fits 274-J Jack. 1/4-28 threaded stud	STANPARGOT	\$0.20		0.18	0.17	0.16
274-SB Two 274-U Plugs with metal links	STANPARZIP	\$0.75				
274-J Fits Type 274 Plugs	STANPARTOP		0.08	0.07	0.06	0.05
938-J Fits Type 274 Plugs	STANPARACT		0.32	0.27	0.25	0.22
938-XB One 938-J and pair of black insulators	STANPARART		0.52	0.39	0.36	0.32
938-XR One 938-J and pair of red insulators	STANPARHIT		0.52	0.39	0.36	0.32

†Net prices. No further quantity discounts.

\*Minimum quantity sold.

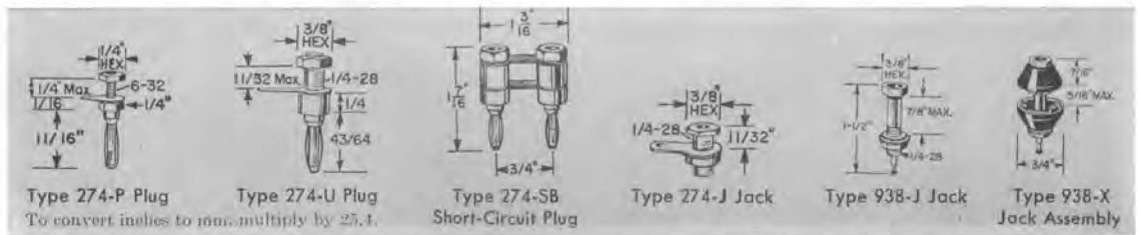

### INSULATED PLUGS

**TYPE 274-DB INSULATED SINGLE PLUG** is a styrene-insulated plug with a jack top. A set-screw clamp is provided on the plug end.

**TYPE 274-MB INSULATED DOUBLE PLUG** is a molded-styrene double-plug assembly which fits TYPE 938 Binding Posts or TYPE 274 Jacks on standard 3/4-inch spacing. The jack top permits stacking for multiple connections. A cross hole through the center provides strain relief for attached cables up to 0.2-inch diameter. The plug is completely insulated.

**TYPE 274-NK SHIELDED DOUBLE PLUG** is a double plug in an aluminum case with ceramic insulation for completely shielded connections to TYPE 938 Binding Posts. Strain relief for coaxial cable of 0.2 and 0.25 inch OD is provided. This plug terminates the TYPE 274-NL Patch Cord (page 241) and TYPE 874-R34 Patch Cord (page 44).

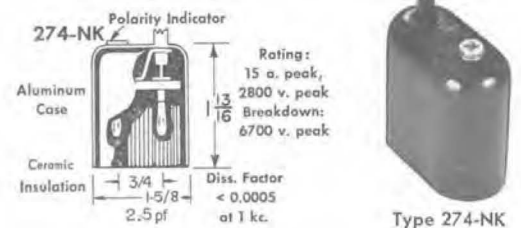
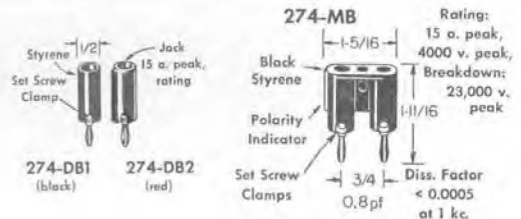

TYPE	CODE WORD	UNIT PRICE† IN LOTS OF				
		5* -9	10- 99	100- 199	200- 999	1000 up
274-DB1 Black Insulated Single Plug	STAPLUGANT	\$0.50	\$0.43	\$0.40	\$0.36	\$0.34
274-DB2 Red Insulated Single Plug	STAPLUGARC	0.50	0.43	0.40	0.36	0.34
274-MB Insulated Double Plug	STANPARBUG	0.65	0.57	0.54	0.49	0.47
274-NK Shielded Double Plug	STAPLUGNUT	\$1.35				

†Net prices. No further quantity discounts.

\*Minimum quantity sold.



# ADAPTORS AND CORDS



Type 874-QBJ



Type 874-Q2

## ADAPTORS

**TYPE 274-QBJ ADAPTOR.** Shielded banana plugs provide connection from binding-post terminals to TYPE BNC plug.

**TYPE 874-Q2 ADAPTOR.** Provides connection from TYPE 274 Plugs to TYPE 874 Coaxial systems.

**TYPE 874-Q9 ADAPTOR.** Provides connection from TYPE 938 Binding Posts to TYPE 874 Coaxial systems.

**TYPE 874-QN6 ADAPTOR.** Fits TYPE 274-NO Patch Cord to connect to TYPE 874 Coaxial systems.

For a complete list of coaxial adaptors, refer to page 42.



Type 874-Q9



Type 874-QN6

TYPE	CODE WORD	PRICE
274-QBJ	STANPARMUG	\$2.50
874-Q2	COAXTIPPER	5.50
874-Q9	COAXPOSTER	6.00
874-QN6	COAXCHOSER	3.75



Capacitance 70 pf  
3a peak rating      1200 v peak, rating  
3400 v peak, break-down



Type 274-NP



Type 274-NO



Type 274-NL

## PATCH CORDS

**TYPE 274-NO UNIVERSAL PATCH CORD** terminates in TYPE 274 Plugs and is the basic unit of a versatile system of connectors. This cord connects directly to TYPES 274 and 938 Jacks, TYPE 938 Binding Posts, and TYPE 838 Alligator Clips. By use of available adaptors (above), connections can be made to GR TYPE 874 Coaxial Elements, military connectors, and vhf and nhf transmission lines.

A shield, **TYPE 274-NT**, is available for use with this cord to provide shielded connections on standard 3/4-inch spacing.

**TYPE 274-NP PATCH CORD** is a three-foot shielded lead terminated with double plugs, which permit stacking for multiple connections.

**TYPE 274-NL PATCH CORD** is a three-foot shielded lead terminated with TYPE 274-NK Shielded Double Plugs (page 240).

TYPE		CODE WORD	PRICE
274-NO	Patch Cord . . . . .	STANPARKID	\$3.25
274-NT	Shield . . . . .	STANPARTAD	0.90
274-NP	Patch Cord . . . . .	STANPARTYAK	3.50
274-NL	Patch Cord . . . . .	STANBUGBAT	4.50

## POWER CORDS

These power cords are 7-foot rubber-covered No. 18 conductors. Plug and connector bodies are molded integrally with the cord and the hammerhead design permits stacking. The three-wire cord is supplied with General Radio ac-operated instruments.

**TYPE CAP-22 3-WIRE POWER CORD.** Electrical ratings are 7 amperes and 230 volts. The connectors designed for 125-volt operation, conform to the *American Standard for Grounding Type Attachment Plug Caps and Receptacles*, ASA C73.1—1957.

**TYPE CAP-35 2-WIRE POWER CORD.** TYPE SJ cord rated by Underwriters Laboratories at 7 amperes and 300 volts rms. Female connector fits either 2-wire or 3-wire plug.

**TYPE 109-A 3-WIRE RECEPTACLE.** Interchangeable with standard 2-wire receptacle to provide a 3-contact power-



Type CAP-35



Type 109-A



Type CAP-22

input receptacle which accepts either 2-wire or 3-wire power cords.

TYPE		CODE WORD	PRICE
CAP-22	3-Wire Power Cord . .	TRUCO	\$2.25
CAP-35	2-Wire Power Cord . .	CORDY	1.75
109-A	3-Wire Receptacle . . .	TRIPU	1.25



# INSTRUMENT CABINETS

General Radio's new color scheme, use of proprietary meter cases, and complete instrument packaging philosophy are some of the results of an appearance-design and mechanical-design program in which human engineering is given its proper emphasis.

General Radio instrument cabinets can be classified into five basic types, each designed to meet specific requirements of function and use. These are the relay-rack, rack-bench, laboratory-bench, Flip-Tilt, and Unit cases. A prominent feature of all these designs is the adaptability to rack mounting of the basically bench-type instruments and, conversely, the bench-type mounting provision in relay-rack instruments.

## RELAY-RACK

General Radio's relay-rack design is used for fairly large instruments, such as the TYPE 1391-B Pulse, Sweep, and Time-Delay Generator. These instruments can be mounted in standard 19-inch relay racks, with front and rear access to the instrument interior without removal of the instrument from the rack. Although designed chiefly for rack mounting, such instruments can be supplied for use out of the relay rack, on a bench, or stacked one above another in a quasi-relay-rack assembly.

Relay-rack-type cabinets are of a heavy-gauge metal capable of supporting the weight of the instrument. These cabinets are mounted in the rack by means of two sheet-metal supports. When the cabinet is mounted in a relay

rack, the instrument can be slid into it from the front, just as a drawer is slid into place. The instrument is held in place by screws going through the panel into the rack. The instrument can then be partly withdrawn and serviced from the front of the rack, or the case can be removed from the instrument at the rear of the rack, with the instrument left mounted in place.

For bench use, the relay-rack instrument can be equipped with end frames that hold the instrument in its cabinet as the rack does, and that serve as carrying handles and supporting feet at the same time. These end frames are designed to nest one above the other so that instruments can be stacked. Holes are provided for bolting the end frames together to make a permanent stack.

## RACK-BENCH

Small and medium-sized instruments, which are commonly used on the bench, are housed in a cabinet having rubber feet, a tilting feature, and an easily removed dust cover. Panel extensions are available to adapt these instruments for relay-rack mounting.

Rack-bench instruments can be lifted by frames on the side panels and can be tilted by the extension of the front feet. Quick-action clamping fasteners hold the dust cover in place and at the same time permit easy removal of the cover. The same screws that hold the instrument sides to the panel also attach the panel extenders installed for relay-rack mounting.

An example of a rack-bench cabinet is seen in the TYPE 1390-B Random Noise Generator.

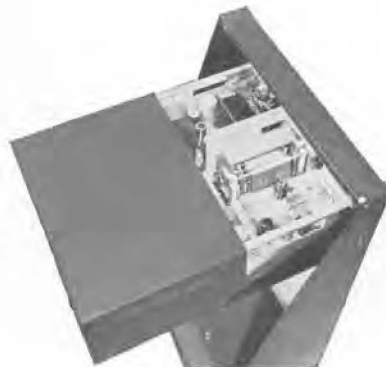

Relay-rack instrument cover is easily removed from rear of rack, as shown at left. With end frames added, instruments can be stacked neatly, as shown at left.



Three aspects of the rack-bench cabinet: left, conventional rack-bench mounting; center, with panel extensions for relay rack; right, tilted for convenient bench use.

### LABORATORY-BENCH

Laboratory instruments, such as impedance standards and decade boxes, are seldom if ever mounted in relay racks, and they are packaged in cases appropriate to their size and weight. Very small units have one-piece drawn-metal boxes, whereas larger units are housed in heavy-gauge aluminum enclosures. These enclosures are fabricated from sawed or extruded plates and are held together by locking strips.



Precision capacitor in laboratory-bench mounting.

### UNIT INSTRUMENTS

For Unit instruments, where economy and small size are the controlling factors, a very simple case is used. The panel is bent into a U, as is the dust cover, and the two interlock firmly to comprise the entire enclosure. Panel adaptors are available for mounting these cabinets in relay racks.

### FLIP-TILT\*

Instruments of a basically portable nature use the General Radio "Flip-Tilt" case, which offers the following features:

It is its own complete carrying case.

It can be bench-mounted at almost any angle from horizontal to vertical for easy viewing and operation.

\*The design of this proprietary Flip-Tilt case is protected by U. S. Patent 2,966,257.

The protective cover is captive, cannot be misplaced.

The lever by which the instrument is swung open or closed also serves as carrying handle in transit.

Storage space for accessories and instruction manual is provided.

A one-piece drawn-aluminum instrument case and control-panel cover results in a lightweight yet sturdy enclosure. The control-panel cover serves as storage space for accessories, and functions as a base when the instrument is in operation. A rubber gasket around the edge of the cover seals the closed case. When the instrument is in use, this gasket provides the friction to keep the instru-

Unit-type cabinet consists of U-shaped chassis, shown here, plus U-shaped dust cover forming top, bottom, and rear.



ment tilted at an angle. The mechanical linkage between the instrument case and the cover is extended in the form of a carrying handle, which also serves as the lever for lifting the instrument while it is being opened or closed.

Flip-Tilt case offers the utmost in versatility and convenience, must be used to be appreciated. See page 22 for other views of this cabinet.





## REACTANCE CHARTS

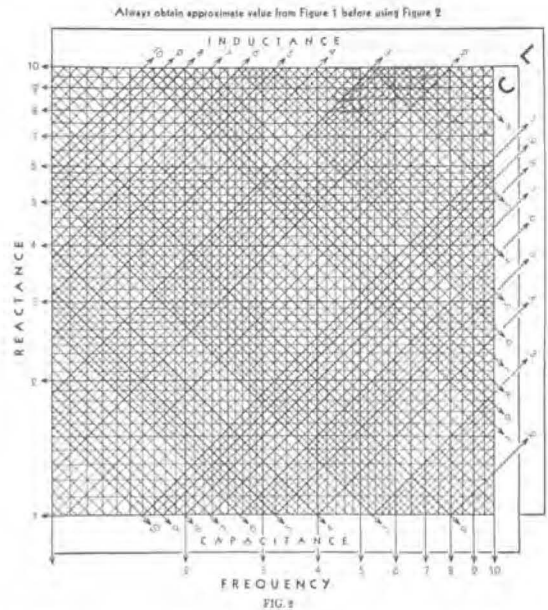
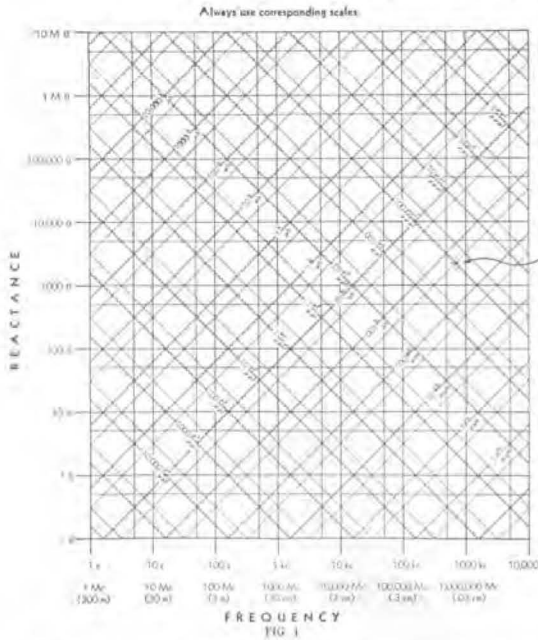

The accompanying chart may be used to find:

- (1) The reactance of a given inductance at a given frequency.
- (2) The reactance of a given capacitance at a given frequency.
- (3) The resonant frequency of a given inductance and capacitance.

In order to facilitate the determination of magnitude of the quantities involved to two or three significant figures the chart is divided into two parts. Figure 1 is the complete chart to be used for rough calculations. Figure 2, which is a single decade of Figure 1 enlarged approximately 7 times, is to be used where the significant two or three figures are to be determined.

### TO FIND REACTANCE

Enter the charts vertically from the bottom (frequency) and along the lines slanting upward to the left (capacitance) or to the right (inductance). Corresponding scales (upper or lower) must be used throughout. Project horizontally to the left from the intersection and read reactance.

### TO FIND RESONANT FREQUENCY

Enter the slanting lines for the given inductance and capacitance. Project downward from their intersection and read resonant frequency from the bottom scale. Corresponding

scales (upper or lower) must be used throughout.

**Example:** The sample point indicated (Figure 1) corresponds to a frequency of about 700 kc for an inductance of 500  $\mu$ h, and a capacitance of 100 pf, giving in either case a reactance of about 2000 ohms. The resonant frequency of a circuit containing these values of inductance and capacitance is, of course, 700 kc approximately.

### USE OF FIGURE 2

Figure 2 is used to obtain additional precision of reading but does not place the decimal point which must be located from a preliminary entry on Figure 1. Since the chart necessarily requires two logarithmic decades for inductance and capacitance for every single decade of frequency and reactance, unless the correct decade for L and C is chosen, the calculated values of reactance and frequency will be in error by a factor of 3.16.

**Example:** (Continued.) The reactance corresponding to 500  $\mu$ h or 100 pf is 2230 ohms at 712 kc, their resonant frequency.

### ENLARGED COPIES

Charts are available in a 17 x 22 sheet for wall mounting and in a two-page (8½ x 11) notebook size, punched for standard 3-ring binding. Free upon request.

DECIBEL CONVERSION TABLES

It is convenient in measurements and calculations on communications systems to express the ratio between any two amounts of electric or acoustic power in units on a logarithmic scale. The *decibel* (1/10th of the *bel*) on the briggsian or base-10 scale and the *neper* on the napierian or base-*e* scale are in almost universal use for this purpose.

Since voltage and current are related to power by impedance, both the *decibel* and the *neper* can be used to express voltage and current ratios, if care is taken to account for the

impedances associated with them. In a similar manner the corresponding acoustical quantities can be compared.

Table I and Table II on the following pages have been prepared to facilitate making conversions in either direction between the number of *decibels* and the corresponding power, voltage, and current ratios. Both tables can also be used for *nepers* and the *mile of standard cable* by applying the conversion factors from the table on the opposite page.

*Decibel*—The number of decibels  $N_{db}$  corresponding to the ratio between two amounts of power  $P_1$  and  $P_2$  is

$$N_{db} = 10 \log_{10} \frac{P_1}{P_2} \quad (1)$$

When two voltages  $E_1$  and  $E_2$  or two currents  $I_1$  and  $I_2$  operate in identical impedances,

$$N_{db} = 20 \log_{10} \frac{E_1}{E_2} \quad (2)$$

and 
$$N_{db} = 20 \log_{10} \frac{I_1}{I_2} \quad (3)$$

If  $E_1$  and  $E_2$  or  $I_1$  and  $I_2$  operate in unequal impedances,

$$N_{db} = 20 \log_{10} \frac{E_1}{E_2} + 10 \log_{10} \frac{Z_2}{Z_1} + 10 \log_{10} \frac{k_1}{k_2} \quad (4)$$

and 
$$N_{db} = 20 \log_{10} \frac{I_1}{I_2} + 10 \log_{10} \frac{Z_1}{Z_2} + 10 \log_{10} \frac{k_1}{k_2} \quad (5)$$

where  $Z_1$  and  $Z_2$  are the absolute magnitudes of the corresponding impedances and  $k_1$  and  $k_2$  are the values of power factor for the impedances.  $E_1$ ,  $E_2$ ,  $I_1$ , and  $I_2$  are also the absolute magnitudes of the corresponding quantities. Note that Table I and Table II can be

used to evaluate the impedance and power factor terms, since both are similar to the expression for power ratio, equation (1).

*Neper*—The number of nepers  $N_{nep}$  corresponding to a power ratio  $\frac{P_1}{P_2}$  is

$$N_{nep} = \frac{1}{2} \log_e \frac{P_1}{P_2} \quad (6)$$

For voltage ratios  $\frac{E_1}{E_2}$  or current ratios  $\frac{I_1}{I_2}$  working in identical impedances,

$$N_{nep} = \log_e \frac{E_1}{E_2} \quad (7)$$

and 
$$N_{nep} = \log_e \frac{I_1}{I_2}$$

When  $E_1$  and  $E_2$  or  $I_1$  and  $I_2$  operate in unequal impedances,

$$N_{nep} = \log_e \frac{E_1}{E_2} + \frac{1}{2} \log_e \frac{Z_2}{Z_1} + \frac{1}{2} \log_e \frac{k_1}{k_2} \quad (8)$$

and 
$$N_{nep} = \log_e \frac{I_1}{I_2} + \frac{1}{2} \log_e \frac{Z_1}{Z_2} + \frac{1}{2} \log_e \frac{k_1}{k_2} \quad (9)$$

where  $Z_1$  and  $Z_2$  and  $k_1$  and  $k_2$  are as in equations (4) and (5).



### RELATIONS BETWEEN DECIBELS, NEPERS, AND MILES OF STANDARD CABLE

<i>Multiply</i>	<i>By</i>	<i>To Find</i>
decibels .....	.1151	nepers
decibels .....	1.056	miles of standard cable
miles of standard cable	.947	decibels
miles of standard cable	.109	nepers
nepers .....	8.686	decibels
nepers .....	9.175	miles of standard cable

### TO FIND VALUES OUTSIDE THE RANGE OF CONVERSION TABLES

Values outside the range of either Table I or Table II on the following pages can be readily found with the help of the following simple rules:

**Table I: Decibels to Voltage and Power Ratios**

**Number of decibels positive (+):** Subtract +20 decibels successively from the given number of decibels until the remainder falls within range of Table I. *To find the voltage ratio*, multiply the corresponding value from the right-hand voltage-ratio column by 10 for each time you subtracted 20 db. *To find the power ratio*, multiply the corresponding value from the right-hand power-ratio column by 100 for each time you subtracted 20 db.

**Example—Given:** 49.2 db.

$$49.2 \text{ db} - 20 \text{ db} - 20 \text{ db} = 9.2 \text{ db}$$

$$\text{Voltage ratio: } 9.2 \text{ db} \rightarrow 2.884$$

$$2.884 \times 10 \times 10 = 288.4 \rightarrow 49.2 \text{ db}$$

$$\text{Power ratio: } 9.2 \text{ db} \rightarrow 8.318$$

$$8.318 \times 100 \times 100 = 83180 \rightarrow 49.2 \text{ db}$$

**Number of decibels negative (-):** Add +20 decibels successively to the given number of decibels until the sum falls within the range of Table I. *For the voltage ratio*, divide the value from the left-hand voltage-ratio column by 10 for each time you added 20 db. *For the power ratio*, divide the value from the left-hand power-ratio column by 100 for each time you added 20 db.

**Example—Given:** -49.2 db

$$-49.2 \text{ db} + 20 \text{ db} + 20 \text{ db} = -9.2 \text{ db}$$

$$\text{Voltage ratio: } -9.2 \text{ db} \rightarrow .3467$$

$$.3467 \times 1/10 \times 1/10 = .003467 \rightarrow -49.2 \text{ db}$$

$$\text{Power ratio: } -9.2 \text{ db} \rightarrow .1202$$

$$.1202 \times 1/100 \times 1/100 = .00001202 \rightarrow -49.2 \text{ db}$$

**Table II: Voltage Ratios to Decibels**

**For ratios smaller than those in table—**Multiply the given ratio by 10 successively until the product can be found in the table. From the number of decibels thus found, subtract +20 decibels for each time you multiplied by 10.

**Example—Given:** Voltage ratio = .0131

$$.0131 \times 10 \times 10 = 1.31$$

From Table II, 1.31 → 2.345 db

$$2.345 \text{ db} - 20 \text{ db} - 20 \text{ db} = -37.655 \text{ db}$$

**For ratios greater than those in table—**Divide the given ratio by 10 successively until the remainder can be found in the table. To the number of decibels thus found, add +20 db for each time you divided by 10.

**Example—Given:** Voltage ratio = 712

$$712 \times 1/10 \times 1/10 = 7.12$$

From Table II, 7.12 → 17.050 db

$$17.050 \text{ db} + 20 \text{ db} + 20 \text{ db} = 57.050 \text{ db}$$





TABLE I

GIVEN: Decibels

TO FIND: Power and  $\left\{ \begin{matrix} \text{Voltage} \\ \text{Current} \end{matrix} \right\}$  Ratios

TO ACCOUNT FOR THE SIGN OF THE DECIBEL

For positive (+) values of the decibel—Both voltage and power ratios are greater than unity. Use the two right-hand columns.

For negative (-) values of the decibel—Both voltage and power ratios are less than unity. Use the two left-hand columns.

Example—Given:  $\pm 9.1$  db Find:

	Power Ratio	Voltage Ratio
+9.1 db	8.128	2.851
-9.1 db	0.1230	0.3508

← -db+ →					← -db+ →				
Voltage Ratio	Power Ratio	db	Voltage Ratio	Power Ratio	Voltage Ratio	Power Ratio	db	Voltage Ratio	Power Ratio
<b>1.0000</b>	<b>1.0000</b>	<b>0</b>	<b>1.000</b>	<b>1.000</b>	<b>.5623</b>	<b>.3162</b>	<b>5.0</b>	<b>1.778</b>	<b>3.162</b>
.9886	.9772	.1	1.012	1.023	.5559	.3090	5.1	1.799	3.236
.9772	.9550	.2	1.023	1.047	.5495	.3020	5.2	1.820	3.311
.9661	.9333	.3	1.035	1.072	.5433	.2951	5.3	1.841	3.388
.9550	.9120	.4	1.047	1.096	.5370	.2884	5.4	1.862	3.467
.9441	.8913	.5	1.059	1.122	.5309	.2818	5.5	1.884	3.548
.9333	.8710	.6	1.072	1.148	.5248	.2754	5.6	1.905	3.631
.9226	.8511	.7	1.084	1.175	.5188	.2692	5.7	1.928	3.715
.9120	.8318	.8	1.096	1.202	.5129	.2630	5.8	1.950	3.802
.9016	.8128	.9	1.109	1.230	.5070	.2570	5.9	1.972	3.890
<b>.8913</b>	<b>.7943</b>	<b>1.0</b>	<b>1.122</b>	<b>1.259</b>	<b>.5012</b>	<b>.2512</b>	<b>6.0</b>	<b>1.995</b>	<b>3.981</b>
.8810	.7762	1.1	1.135	1.288	.4955	.2455	6.1	2.018	4.074
.8710	.7586	1.2	1.148	1.318	.4898	.2399	6.2	2.042	4.169
.8610	.7413	1.3	1.161	1.349	.4842	.2344	6.3	2.065	4.266
.8511	.7244	1.4	1.175	1.380	.4786	.2291	6.4	2.089	4.365
.8414	.7079	1.5	1.189	1.413	.4732	.2239	6.5	2.113	4.467
.8318	.6918	1.6	1.202	1.445	.4677	.2188	6.6	2.138	4.571
.8222	.6761	1.7	1.216	1.479	.4624	.2138	6.7	2.163	4.677
.8128	.6607	1.8	1.230	1.514	.4571	.2089	6.8	2.188	4.786
.8035	.6457	1.9	1.245	1.549	.4519	.2042	6.9	2.213	4.898
<b>.7943</b>	<b>.6310</b>	<b>2.0</b>	<b>1.259</b>	<b>1.585</b>	<b>.4467</b>	<b>.1995</b>	<b>7.0</b>	<b>2.239</b>	<b>5.012</b>
.7852	.6166	2.1	1.274	1.622	.4416	.1950	7.1	2.265	5.129
.7762	.6026	2.2	1.288	1.660	.4365	.1905	7.2	2.291	5.248
.7674	.5888	2.3	1.303	1.698	.4315	.1862	7.3	2.317	5.370
.7586	.5754	2.4	1.318	1.738	.4266	.1820	7.4	2.344	5.495
.7499	.5623	2.5	1.334	1.778	.4217	.1778	7.5	2.371	5.623
.7413	.5495	2.6	1.349	1.820	.4169	.1738	7.6	2.399	5.754
.7328	.5370	2.7	1.365	1.862	.4121	.1698	7.7	2.427	5.888
.7244	.5248	2.8	1.380	1.905	.4074	.1660	7.8	2.455	6.026
.7161	.5129	2.9	1.396	1.950	.4027	.1622	7.9	2.483	6.166
<b>.7079</b>	<b>.5012</b>	<b>3.0</b>	<b>1.413</b>	<b>1.995</b>	<b>.3981</b>	<b>.1585</b>	<b>8.0</b>	<b>2.512</b>	<b>6.310</b>
.6998	.4898	3.1	1.429	2.042	.3936	.1549	8.1	2.541	6.457
.6918	.4786	3.2	1.445	2.089	.3890	.1514	8.2	2.570	6.607
.6839	.4677	3.3	1.462	2.138	.3846	.1479	8.3	2.600	6.761
.6761	.4571	3.4	1.479	2.188	.3802	.1445	8.4	2.630	6.918
.6683	.4467	3.5	1.496	2.239	.3758	.1413	8.5	2.661	7.079
.6607	.4365	3.6	1.514	2.291	.3715	.1380	8.6	2.692	7.244
.6531	.4266	3.7	1.531	2.344	.3673	.1349	8.7	2.723	7.413
.6457	.4169	3.8	1.549	2.399	.3631	.1318	8.8	2.754	7.586
.6383	.4074	3.9	1.567	2.455	.3589	.1288	8.9	2.786	7.762
<b>.6310</b>	<b>.3981</b>	<b>4.0</b>	<b>1.585</b>	<b>2.512</b>	<b>.3548</b>	<b>.1259</b>	<b>9.0</b>	<b>2.818</b>	<b>7.943</b>
.6237	.3890	4.1	1.603	2.570	.3508	.1230	9.1	2.851	8.128
.6166	.3802	4.2	1.622	2.630	.3467	.1202	9.2	2.884	8.318
.6095	.3715	4.3	1.641	2.692	.3428	.1175	9.3	2.917	8.511
.6026	.3631	4.4	1.660	2.754	.3388	.1148	9.4	2.951	8.710
.5957	.3548	4.5	1.679	2.818	.3350	.1122	9.5	2.985	8.913
.5888	.3467	4.6	1.698	2.884	.3311	.1096	9.6	3.020	9.120
.5821	.3388	4.7	1.718	2.951	.3273	.1072	9.7	3.055	9.333
.5754	.3311	4.8	1.738	3.020	.3236	.1047	9.8	3.090	9.550
.5689	.3236	4.9	1.758	3.090	.3199	.1023	9.9	3.126	9.772



TABLE I (continued)

← -db+ →			← -db+ →			← -db+ →			
Voltage Ratio	Power Ratio	db	Voltage Ratio	Power Ratio	Voltage Ratio	Power Ratio	db	Voltage Ratio	Power Ratio
<b>.3162</b>	<b>.1000</b>	<b>10.0</b>	<b>3.162</b>	<b>10.000</b>	<b>.1585</b>	<b>.02512</b>	<b>16.0</b>	<b>6.310</b>	<b>39.81</b>
.3126	.09772	10.1	3.199	10.23	.1567	.02455	16.1	6.383	40.74
.3090	.09550	10.2	3.236	10.47	.1549	.02399	16.2	6.457	41.69
.3055	.09333	10.3	3.273	10.72	.1531	.02344	16.3	6.531	42.66
.3020	.09120	10.4	3.311	10.96	.1514	.02291	16.4	6.607	43.65
.2985	.08913	10.5	3.350	11.22	.1496	.02239	16.5	6.683	44.67
.2951	.08710	10.6	3.388	11.48	.1479	.02188	16.6	6.761	45.71
.2917	.08511	10.7	3.428	11.75	.1462	.02138	16.7	6.839	46.77
.2884	.08318	10.8	3.467	12.02	.1445	.02089	16.8	6.918	47.86
.2851	.08128	10.9	3.508	12.30	.1429	.02042	16.9	6.998	48.98
<b>.2818</b>	<b>.07943</b>	<b>11.0</b>	<b>3.548</b>	<b>12.59</b>	<b>.1413</b>	<b>.01995</b>	<b>17.0</b>	<b>7.079</b>	<b>50.12</b>
.2786	.07762	11.1	3.589	12.88	.1396	.01950	17.1	7.161	51.29
.2754	.07586	11.2	3.631	13.18	.1380	.01905	17.2	7.244	52.48
.2723	.07413	11.3	3.673	13.49	.1365	.01862	17.3	7.328	53.70
.2692	.07244	11.4	3.715	13.80	.1349	.01820	17.4	7.413	54.95
.2661	.07079	11.5	3.758	14.13	.1334	.01778	17.5	7.499	56.23
.2630	.06918	11.6	3.802	14.45	.1318	.01738	17.6	7.586	57.54
.2600	.06761	11.7	3.846	14.79	.1303	.01698	17.7	7.674	58.88
.2570	.06607	11.8	3.890	15.14	.1288	.01660	17.8	7.762	60.26
.2541	.06457	11.9	3.936	15.49	.1274	.01622	17.9	7.852	61.66
<b>.2512</b>	<b>.06310</b>	<b>12.0</b>	<b>3.981</b>	<b>15.85</b>	<b>.1259</b>	<b>.01585</b>	<b>18.0</b>	<b>7.943</b>	<b>63.10</b>
.2483	.06166	12.1	4.027	16.22	.1245	.01549	18.1	8.035	64.57
.2455	.06026	12.2	4.074	16.60	.1230	.01514	18.2	8.128	66.07
.2427	.05888	12.3	4.121	16.98	.1216	.01479	18.3	8.222	67.61
.2399	.05754	12.4	4.169	17.38	.1202	.01445	18.4	8.318	69.18
.2371	.05623	12.5	4.217	17.78	.1189	.01413	18.5	8.414	70.79
.2344	.05495	12.6	4.266	18.20	.1175	.01380	18.6	8.511	72.44
.2317	.05370	12.7	4.315	18.62	.1161	.01349	18.7	8.610	74.13
.2291	.05248	12.8	4.365	19.05	.1148	.01318	18.8	8.710	75.86
.2265	.05129	12.9	4.416	19.50	.1135	.01288	18.9	8.811	77.62
<b>.2239</b>	<b>.05012</b>	<b>13.0</b>	<b>4.467</b>	<b>19.95</b>	<b>.1122</b>	<b>.01259</b>	<b>19.0</b>	<b>8.913</b>	<b>79.43</b>
.2213	.04898	13.1	4.519	20.42	.1109	.01230	19.1	9.016	81.28
.2188	.04786	13.2	4.571	20.89	.1096	.01202	19.2	9.120	83.18
.2163	.04677	13.3	4.624	21.38	.1084	.01175	19.3	9.226	85.11
.2138	.04571	13.4	4.677	21.88	.1072	.01148	19.4	9.333	87.10
.2113	.04467	13.5	4.732	22.39	.1059	.01122	19.5	9.441	89.13
.2089	.04365	13.6	4.786	22.91	.1047	.01096	19.6	9.550	91.20
.2065	.04266	13.7	4.842	23.44	.1035	.01072	19.7	9.661	93.33
.2042	.04169	13.8	4.898	23.99	.1023	.01047	19.8	9.772	95.50
.2018	.04074	13.9	4.955	24.55	.1012	.01023	19.9	9.886	97.72
<b>.1995</b>	<b>.03981</b>	<b>14.0</b>	<b>5.012</b>	<b>25.12</b>	<b>.1000</b>	<b>.01000</b>	<b>20.0</b>	<b>10.000</b>	<b>100.00</b>
.1972	.03890	14.1	5.070	25.70					
.1950	.03802	14.2	5.129	26.30					
.1928	.03715	14.3	5.188	26.92					
.1905	.03631	14.4	5.248	27.54					
.1884	.03548	14.5	5.309	28.18					
.1862	.03467	14.6	5.370	28.84					
.1841	.03388	14.7	5.433	29.51					
.1820	.03311	14.8	5.495	30.20					
.1799	.03236	14.9	5.559	30.90					
<b>.1778</b>	<b>.03162</b>	<b>15.0</b>	<b>5.623</b>	<b>31.62</b>					
.1758	.03090	15.1	5.689	32.36					
.1738	.03020	15.2	5.754	33.11					
.1718	.02951	15.3	5.821	33.88					
.1698	.02884	15.4	5.888	34.67					
.1679	.02818	15.5	5.957	35.48					
.1660	.02754	15.6	6.026	36.31					
.1641	.02692	15.7	6.095	37.15					
.1622	.02630	15.8	6.166	38.02					
.1603	.02570	15.9	6.237	38.90					
							← -db+ →		
					<i>Voltage Ratio</i>	<i>Power Ratio</i>	<i>db</i>	<i>Voltage Ratio</i>	<i>Power Ratio</i>
					<b>3.162 × 10<sup>-1</sup></b>	<b>10<sup>-1</sup></b>	<b>10</b>	<b>3.162</b>	<b>10</b>
					10 <sup>-1</sup>	10 <sup>-2</sup>	20	10	10 <sup>2</sup>
					<b>3.162 × 10<sup>-2</sup></b>	10 <sup>-3</sup>	30	<b>3.162 × 10</b>	10 <sup>3</sup>
					10 <sup>-2</sup>	10 <sup>-4</sup>	40	10 <sup>2</sup>	10 <sup>4</sup>
					<b>3.162 × 10<sup>-3</sup></b>	10 <sup>-5</sup>	50	<b>3.162 × 10<sup>2</sup></b>	10 <sup>5</sup>
					10 <sup>-3</sup>	10 <sup>-6</sup>	60	10 <sup>3</sup>	10 <sup>6</sup>
					<b>3.162 × 10<sup>-4</sup></b>	10 <sup>-7</sup>	70	<b>3.162 × 10<sup>3</sup></b>	10 <sup>7</sup>
					10 <sup>-4</sup>	10 <sup>-8</sup>	80	10 <sup>4</sup>	10 <sup>8</sup>
					<b>3.162 × 10<sup>-5</sup></b>	10 <sup>-9</sup>	90	<b>3.162 × 10<sup>4</sup></b>	10 <sup>9</sup>
					10 <sup>-5</sup>	10 <sup>-10</sup>	100	10 <sup>5</sup>	10 <sup>10</sup>

To find decibel values outside the range of this table, see page 246.



**TABLE II**

**GIVEN:**  $\left\{ \begin{array}{l} \text{Voltage} \\ \text{Current} \end{array} \right\}$  Ratio

**TO FIND:** Decibels

**POWER RATIOS**

To find the number of decibels corresponding to a given power ratio—Assume the given power ratio to be a voltage ratio and find the corresponding number of decibels from the table. The desired result is exactly one-half of the number of decibels thus found.

**Example—** Given: a power ratio of 3.41.  
Find: 3.41 in the table:

$$3.41 \rightarrow 10.655 \text{ db (voltage)}$$

$$10.655 \text{ db} \times \frac{1}{2} = 5.328 \text{ db (power)}$$

Voltage Ratio	.00	.01	.02	.03	.04	.05	.06	.07	.08	.09
1.0	.000	.086	.172	.257	.341	.424	.506	.588	.668	.749
1.1	.828	.906	.984	1.062	1.138	1.214	1.289	1.364	1.438	1.511
1.2	1.584	1.656	1.727	1.798	1.868	1.938	2.007	2.076	2.144	2.212
1.3	2.279	2.345	2.411	2.477	2.542	2.607	2.671	2.734	2.798	2.860
1.4	2.923	2.984	3.046	3.107	3.167	3.227	3.287	3.346	3.405	3.464
1.5	3.522	3.580	3.637	3.694	3.750	3.807	3.862	3.918	3.973	4.028
1.6	4.082	4.137	4.190	4.244	4.297	4.350	4.402	4.454	4.506	4.558
1.7	4.609	4.660	4.711	4.761	4.811	4.861	4.910	4.959	5.008	5.057
1.8	5.105	5.154	5.201	5.249	5.296	5.343	5.390	5.437	5.483	5.529
1.9	5.575	5.621	5.666	5.711	5.756	5.801	5.845	5.889	5.933	5.977
2.0	6.021	6.064	6.107	6.150	6.193	6.235	6.277	6.319	6.361	6.403
2.1	6.444	6.486	6.527	6.568	6.608	6.649	6.689	6.729	6.769	6.809
2.2	6.848	6.888	6.927	6.966	7.008	7.044	7.082	7.121	7.159	7.197
2.3	7.235	7.272	7.310	7.347	7.384	7.421	7.458	7.495	7.532	7.568
2.4	7.604	7.640	7.676	7.712	7.748	7.783	7.819	7.854	7.889	7.924
2.5	7.959	7.993	8.028	8.062	8.097	8.131	8.165	8.199	8.232	8.266
2.6	8.299	8.333	8.366	8.399	8.432	8.465	8.498	8.530	8.563	8.595
2.7	8.627	8.659	8.691	8.723	8.755	8.787	8.818	8.850	8.881	8.912
2.8	8.943	8.974	9.005	9.036	9.066	9.097	9.127	9.158	9.188	9.218
2.9	9.248	9.278	9.308	9.337	9.367	9.396	9.426	9.455	9.484	9.513
3.0	9.542	9.571	9.600	9.629	9.657	9.686	9.714	9.743	9.771	9.799
3.1	9.827	9.855	9.883	9.911	9.939	9.966	9.994	10.021	10.049	10.076
3.2	10.103	10.130	10.157	10.184	10.211	10.238	10.264	10.291	10.317	10.344
3.3	10.370	10.397	10.423	10.449	10.475	10.501	10.527	10.553	10.578	10.604
3.4	10.630	10.655	10.681	10.706	10.731	10.756	10.782	10.807	10.832	10.857
3.5	10.881	10.906	10.931	10.955	10.980	11.005	11.029	11.053	11.078	11.102
3.6	11.126	11.150	11.174	11.198	11.222	11.246	11.270	11.293	11.317	11.341
3.7	11.364	11.387	11.411	11.434	11.457	11.481	11.504	11.527	11.550	11.573
3.8	11.596	11.618	11.641	11.664	11.687	11.709	11.732	11.754	11.777	11.799
3.9	11.821	11.844	11.866	11.888	11.910	11.932	11.954	11.976	11.998	12.019
4.0	12.041	12.063	12.085	12.106	12.128	12.149	12.171	12.192	12.213	12.234
4.1	12.256	12.277	12.298	12.319	12.340	12.361	12.382	12.403	12.424	12.444
4.2	12.465	12.486	12.506	12.527	12.547	12.568	12.588	12.609	12.629	12.649
4.3	12.669	12.690	12.710	12.730	12.750	12.770	12.790	12.810	12.829	12.849
4.4	12.869	12.889	12.908	12.928	12.948	12.967	12.987	13.006	13.026	13.045
4.5	13.064	13.084	13.103	13.122	13.141	13.160	13.179	13.198	13.217	13.236
4.6	13.255	13.274	13.293	13.312	13.330	13.349	13.368	13.386	13.405	13.423
4.7	13.442	13.460	13.479	13.497	13.516	13.534	13.552	13.570	13.589	13.607
4.8	13.625	13.643	13.661	13.679	13.697	13.715	13.733	13.751	13.768	13.786
4.9	13.804	13.822	13.839	13.857	13.875	13.892	13.910	13.927	13.945	13.962
5.0	13.979	13.997	14.014	14.031	14.049	14.066	14.083	14.100	14.117	14.134
5.1	14.151	14.168	14.185	14.202	14.219	14.236	14.253	14.270	14.287	14.303
5.2	14.320	14.337	14.353	14.370	14.387	14.403	14.420	14.436	14.453	14.469
5.3	14.486	14.502	14.518	14.535	14.551	14.567	14.583	14.599	14.616	14.632
5.4	14.648	14.664	14.680	14.696	14.712	14.728	14.744	14.760	14.776	14.791
5.5	14.807	14.823	14.839	14.855	14.870	14.886	14.902	14.917	14.933	14.948
5.6	14.964	14.979	14.995	15.010	15.026	15.041	15.056	15.072	15.087	15.102
5.7	15.117	15.133	15.148	15.163	15.178	15.193	15.208	15.224	15.239	15.254
5.8	15.269	15.284	15.298	15.313	15.328	15.343	15.358	15.373	15.388	15.402
5.9	15.417	15.432	15.446	15.461	15.476	15.490	15.505	15.519	15.534	15.549





**TABLE II (continued)**

<i>Voltage Ratio</i>	.00	.01	.02	.03	.04	.05	.06	.07	.08	.09
<b>6.0</b>	<b>15.563</b>	<b>15.577</b>	<b>15.592</b>	<b>15.606</b>	<b>15.621</b>	<b>15.635</b>	<b>15.649</b>	<b>15.664</b>	<b>15.678</b>	<b>15.692</b>
6.1	15.707	15.721	15.735	15.749	15.763	15.778	15.792	15.806	15.820	15.834
6.2	15.848	15.862	15.876	15.890	15.904	15.918	15.931	15.945	15.959	15.973
6.3	15.987	16.001	16.014	16.028	16.042	16.055	16.069	16.083	16.096	16.110
6.4	16.124	16.137	16.151	16.164	16.178	16.191	16.205	16.218	16.232	16.245
6.5	16.258	16.272	16.285	16.298	16.312	16.325	16.338	16.351	16.365	16.378
6.6	16.391	16.404	16.417	16.430	16.443	16.456	16.469	16.483	16.496	16.509
6.7	16.521	16.534	16.547	16.560	16.573	16.586	16.599	16.612	16.625	16.637
6.8	16.650	16.663	16.676	16.688	16.701	16.714	16.726	16.739	16.752	16.764
6.9	16.777	16.790	16.802	16.815	16.827	16.840	16.852	16.865	16.877	16.890
<b>7.0</b>	<b>16.902</b>	<b>16.914</b>	<b>16.927</b>	<b>16.939</b>	<b>16.951</b>	<b>16.964</b>	<b>16.976</b>	<b>16.988</b>	<b>17.001</b>	<b>17.013</b>
7.1	17.025	17.037	17.050	17.062	17.074	17.086	17.098	17.110	17.122	17.135
7.2	17.147	17.159	17.171	17.183	17.195	17.207	17.219	17.231	17.243	17.255
7.3	17.266	17.278	17.290	17.302	17.314	17.326	17.338	17.349	17.361	17.373
7.4	17.385	17.396	17.408	17.420	17.431	17.443	17.455	17.466	17.478	17.490
7.5	17.501	17.513	17.524	17.536	17.547	17.559	17.570	17.582	17.593	17.605
7.6	17.616	17.628	17.639	17.650	17.662	17.673	17.685	17.696	17.707	17.719
7.7	17.730	17.741	17.752	17.764	17.775	17.786	17.797	17.808	17.820	17.831
7.8	17.842	17.853	17.864	17.875	17.886	17.897	17.908	17.919	17.931	17.942
7.9	17.953	17.964	17.975	17.985	17.996	18.007	18.018	18.029	18.040	18.051
<b>8.0</b>	<b>18.062</b>	<b>18.073</b>	<b>18.083</b>	<b>18.094</b>	<b>18.105</b>	<b>18.116</b>	<b>18.127</b>	<b>18.137</b>	<b>18.148</b>	<b>18.159</b>
8.1	18.170	18.180	18.191	18.202	18.212	18.223	18.234	18.244	18.255	18.266
8.2	18.276	18.287	18.297	18.308	18.319	18.329	18.340	18.350	18.361	18.371
8.3	18.382	18.392	18.402	18.413	18.423	18.434	18.444	18.455	18.465	18.475
8.4	18.486	18.496	18.506	18.517	18.527	18.537	18.547	18.558	18.568	18.578
8.5	18.588	18.599	18.609	18.619	18.629	18.639	18.649	18.660	18.670	18.680
8.6	18.690	18.700	18.710	18.720	18.730	18.740	18.750	18.760	18.770	18.780
8.7	18.790	18.800	18.810	18.820	18.830	18.840	18.850	18.860	18.870	18.880
8.8	18.890	18.900	18.909	18.919	18.929	18.939	18.949	18.958	18.968	18.978
8.9	18.988	18.998	19.007	19.017	19.027	19.036	19.046	19.056	19.066	19.075
<b>9.0</b>	<b>19.085</b>	<b>19.094</b>	<b>19.104</b>	<b>19.114</b>	<b>19.123</b>	<b>19.133</b>	<b>19.143</b>	<b>19.152</b>	<b>19.162</b>	<b>19.171</b>
9.1	19.181	19.190	19.200	19.209	19.219	19.228	19.238	19.247	19.257	19.266
9.2	19.276	19.285	19.295	19.304	19.313	19.323	19.332	19.342	19.351	19.360
9.3	19.370	19.379	19.388	19.398	19.407	19.416	19.426	19.435	19.444	19.453
9.4	19.463	19.472	19.481	19.490	19.499	19.509	19.518	19.527	19.536	19.545
9.5	19.554	19.564	19.573	19.582	19.591	19.600	19.609	19.618	19.627	19.636
9.6	19.645	19.654	19.664	19.673	19.682	19.691	19.700	19.709	19.718	19.726
9.7	19.735	19.744	19.753	19.762	19.771	19.780	19.789	19.798	19.807	19.816
9.8	19.825	19.833	19.842	19.851	19.860	19.869	19.878	19.886	19.895	19.904
9.9	19.913	19.921	19.930	19.939	19.948	19.956	19.965	19.974	19.983	19.991

<i>Voltage Ratio</i>	0	1	2	3	4	5	6	7	8	9
<b>10</b>	<b>20.000</b>	<b>20.828</b>	<b>21.584</b>	<b>22.279</b>	<b>22.923</b>	<b>23.522</b>	<b>24.082</b>	<b>24.609</b>	<b>25.105</b>	<b>25.575</b>
20	26.021	26.444	26.848	27.235	27.604	27.959	28.299	28.627	28.943	29.248
30	29.542	29.827	30.103	30.370	30.630	30.881	31.126	31.364	31.596	31.821
40	32.041	32.256	32.465	32.669	32.869	33.064	33.255	33.442	33.625	33.804
50	33.979	34.151	34.320	34.486	34.648	34.807	34.964	35.117	35.269	35.417
60	35.563	35.707	35.848	35.987	36.124	36.258	36.391	36.521	36.650	36.777
70	36.902	37.025	37.147	37.266	37.385	37.501	37.616	37.730	37.842	37.953
80	38.062	38.170	38.276	38.382	38.486	38.588	38.690	38.790	38.890	38.988
90	39.085	39.181	39.276	39.370	39.463	39.554	39.645	39.735	39.825	39.913
<b>100</b>	<b>40.000</b>	—	—	—	—	—	—	—	—	—

To find ratios outside the range of this table, see page 246.





<i>Type</i>	<i>Name</i>	<i>Page</i>	<i>Type</i>	<i>Name</i>	<i>Page</i>
CAP-22	3-Wire Power Cord . . .	241	908-P	Dial Drives . . . . .	146
CAP-35	2-Wire Power Cord . . .	241	908-R96	Dial Drive . . . . .	146
DNT	Detectors . . . . .	58	916-AL	Radio-Frequency Bridge . . .	32
KN	Knobs . . . . .	236	938	Binding Posts and Jacks . . .	238
M2	Variaac® Autotransformers	210	940	Decade Inductors . . . . .	177
M5	Variaac® Autotransformers	210	941-A	Toroidal Transformer . . . . .	237
M10	Variaac® Autotransformers	210	970-P	Potentiometer Dial	
M20	Variaac® Autotransformers	210		Plates . . . . .	233
M-type	Ganged Variacs . . . . .	211	971-976	Potentiometers . . . . .	231
VB, VBT	Replacement Brushes		980	Decade Capacitor Units . . . . .	166
	202, 203, 211		1000-P3	Voltage Divider . . . . .	92
W2	Variaac® Autotransformers	202	1000-P4	Dummy Antenna . . . . .	92
W5	Variaac® Autotransformers	202	1000-P5	Transformer . . . . .	92
W10	Variaac® Autotransformers	202	1000-P6	Crystal Diode Modulator . . . .	92
W20	Variaac® Autotransformers	202	1000-P7	Balanced Modulator . . . . .	92
W30	Variaac® Autotransformers	202	1000-P10	Test Loop . . . . .	92
W50	Variaac® Autotransformers	202	1001-A	Standard-Signal	
50-P1, -P2	Power Chokes . . . . .	205		Generator . . . . .	86
W5MT3A	Metered Variaac . . . . .	217	1021-AU, -AV	Standard-Signal	
W5MT3W	Metered Variaac . . . . .	217		Generator . . . . .	90
W5MT3AW	Metered Variaac . . . . .	217	1021-P1	Power-Supply Unit and	
W10MT3A	Metered Variaac . . . . .	217		Cabinet . . . . .	91
W10MT3W	Metered Variaac . . . . .	217	1021-P2, -P3B	Oscillator Units . . . . .	91
W-Series	Variacs . . . . .	205	1103-B	Synchrometer . . . . .	71
107	Variable Inductors . . . . .	175	1105-B	Frequency Measuring	
109-A	Three-Wire Receptacle . . . . .	241		Equipment . . . . .	74
274	Plugs and Jacks . . . . .	240	1106	Frequency Transfer Units . . . . .	75
274	Patch Cords . . . . .	241	1107-A	Interpolation Oscillator . . . . .	75
314-SS6	Variable Delay Line . . . . .	122	1108-B	Coupling Panel . . . . .	75
500	Resistors . . . . .	155	1109-B	Comparison Oscilloscope . . . . .	75
505	Capacitors . . . . .	170	1112-A, -B	Frequency Multipliers . . . . .	72
510	Decade Resistance Units . . . . .	151	1113-A	Standard-Frequency	
544-B	Megohm Bridge . . . . .	8		Oscillator . . . . .	70
544-P3	AC Power-Supply Unit . . . . .	9	1114-A	Frequency Divider . . . . .	70
544-P10	Battery Power-Supply		1116-A	Emergency Power Supply . . . . .	69
	Unit . . . . .	9	1120-A	Frequency Standard . . . . .	68
546-C	AF Microvolter . . . . .	131	1120-AH	1000-Mc Frequency	
583-A	Output Power Meter . . . . .	134		Standard . . . . .	68
578	Shielded Transformers . . . . .	237	1130-A	Digital Time and Fre-	
716-C	Capacitance Bridge . . . . .	13		quency Meter . . . . .	76
716-CS1	Capacitance Bridge . . . . .	33	1130-P	Time-Base Units . . . . .	79
716-P4	Guard Circuit . . . . .	15	1131-P	Counting Decades . . . . .	81
736-A	Wave Analyzer . . . . .	225	1132-A	Data Printer . . . . .	78
740-B	Capacitance Test Bridge . . . . .	12	1134-A	Digital-to-Analog	
783-A	Output Power Meter . . . . .	134		Converter . . . . .	80
805-C	Standard-Signal		1142-A	Frequency Meter and	
	Generator . . . . .	88		Discriminator . . . . .	83
838-B	Alligator Clips . . . . .	239	1201-B	Unit Regulated Power	
874	Coaxial Elements			Supply . . . . .	137
	See index on . . . . .	39	1203-B	Unit Power Supply . . . . .	137
874-LBA	Slotted Line and Vernier . . . . .	52	1205-B	Adjustable Regulated	
901	Dials . . . . .	235		Power Supply . . . . .	136
902	Dials . . . . .	235	1206-B	Unit Amplifier . . . . .	64
904	Dials . . . . .	235	1208-B	Unit Oscillator . . . . .	110
907	Dials . . . . .	234	1209-B, -BL	Unit Oscillator . . . . .	110
907-R144	Dial Drive . . . . .	146	1210-C	Unit R-C Oscillator . . . . .	102
908	Dials . . . . .	234	1211-B	Unit Oscillator . . . . .	107

# INDEX



## TYPE

<i>Type</i>	<i>Name</i>	<i>Page</i>	<i>Type</i>	<i>Name</i>	<i>Page</i>
1212-A	Unit Null Detector . . .	61	1521-A	Graphic-Level Recorder . . .	141
1212-P1,-P2	Filters . . . . .	62	1521-P	Recorder Accessories . . .	143
1213-D	Unit Time/Frequency Calibrator . . . . .	82	1531-A	Strobotac® Electronic Stroboscope . . . . .	196
1214-A,-D,-M	Unit Oscillators . . . . .	106	1532-D	Strobolume . . . . .	197
1215-B	Unit Oscillator . . . . .	110	1532-P1	Replacement Lamp . . . .	197
1216-A	Unit I-F Amplifier . . . .	59	1532-P2	Transformer Cable . . . .	197
1217-A	Unit Pulsar . . . . .	115	1535-B	Contactors . . . . .	198
1218-A	Unit Oscillator . . . . .	110	1535-P1	Adaptor Cable . . . . .	198
1219-A	Unit Pulse Amplifier . . .	119	1550-A	Octave-Band Noise Analyzer . . . . .	191
1220-A	Unit Klystron Oscillator .	113	1550-P1	Adaptor Microphone Plug	191
1230-A,-AE	DC Amplifier and Electrometer . . . . .	128	1551-C	Sound-Level Meter . . . .	182
1230-P1	Component Shield . . . .	129	1551-P1	Condenser Microphone System . . . . .	184
1232-A	Tuned Amplifier and Null Detector . . . . .	60	1551-P2	Leather Carrying Case . .	184
1233-A	Power Amplifier . . . . .	63	1552-B	Sound-Level Calibrator . .	187
1261-A	Power Supply . . . . .	137	1553-A	Vibration Meter . . . . .	192
1262-B	Power Supply . . . . .	137	1554-A	Sound and Vibration Analyzer . . . . .	189
1263-B	Amplitude-Regulating Power Supply . . . . .	138	1555-A	Sound-Survey Meter . . . .	181
1264-A	Modulating Power Supply	139	1555-P2	Leather Carrying Case . .	181
1300-A	Beat-Frequency Video Generator . . . . .	104	1556-A	Impact Noise Analyzer . .	188
1301-A	Low-Distortion Oscillator	98	1557-A	Vibration Calibrator . . .	194
1301-P1	Range-Extension Unit . . .	98	1560-P	Sound and Vibration Accessories . . . . .	185
1302-A	Oscillator . . . . .	99	1560-P11	Vibration Pickup System	185
1304-B	Beat-Frequency Audio Generator . . . . .	100	1560-P12	Dynamic Microphone System . . . . .	186
1305-A	Low-Frequency Oscillator	96	1560-P21	Control Box . . . . .	185
1307-A	Transistor Oscillator . . .	106	1560-P31	Leather Carrying Case . .	187
1330-A	Bridge Oscillator . . . . .	108	1560-P34	Tripod and Extension Cable . . . . .	185
1361-A	UHF Oscillator . . . . .	109	1560-P51	Vibration Pickup . . . . .	185
1390-B	Random-Noise Generator	123	1560-P91	Adaptor . . . . .	185
1391-B	Pulse, Sweep, and Time- Delay Generator . . . . .	116	1560-P94	Adaptor Cable . . . . .	185
1392-A	Time-Delay Generator . . .	120	1570	Automatic Voltage Regulator . . . . .	218
1401	Standard Air Capacitors (2 Terminal) . . . . .	161	1570-AS15	Militarized Voltage Regulator . . . . .	220
1403	Standard Air Capacitors (3 Terminal) . . . . .	162	1590-A	Remote Control for Va- riac® Autotransformers	216
1409	Standard Capacitors . . . .	163	1602-B	UHF Admittance Meter . .	34
1419	Decade Capacitors . . . . .	168	1603-A	Z-Y Bridge . . . . .	24
1420	Variable Air Capacitors . .	230	1605-A	Impedance Comparator . .	26
1421	Variable Air Capacitors . .	230	1605-AH	Impedance Comparator . .	26
1422	Precision Air Capacitors .	158	1606-A	RF Bridge . . . . .	30
1423-A	Precision Decade Capacitor . . . . .	165	1606-P1	Luggage-Type Carrying Case . . . . .	31
1424-A	Standard Polystyrene Capacitor . . . . .	164	1607-A	Transfer-Function and Immittance Bridge . . . .	36
1429-A	Fuel-Gage Tester . . . . .	171	1607-P	Transistor and Tube Mounts . . . . .	37
1432	Decade Resistors . . . . .	149	1610-AH	Capacitance Measuring Assembly . . . . .	15
1450	Decade Attenuators . . . .	153	1610-B	Capacitance Measuring Assembly . . . . .	15
1454	Decade Voltage Dividers	154			
1481	Inductors . . . . .	176			
1482	Standard Inductors . . . .	173			
1490	Decade Inductors . . . . .	178			



<i>Type</i>	<i>Name</i>	<i>Page</i>	<i>Type</i>	<i>Name</i>	<i>Page</i>
1610-B2	Capacitance Measuring Assembly	15	1701	Variac® Speed Controls	222
1611-B	Capacitance Test Bridge	10	1702	Variac® Speed Controls	222
1613-A	Capacitance Bridge	18	1702-P3	Switch	223
1613-K	Capacitance Bridge	18	1703	Variac® Speed Controls	222
1632-A	Inductance Bridge	20	1705-P1	Drum Controller	223
1650-A	Impedance Bridge	22	1750-A	Sweep Drive	144
1650-P1	Test Jig	23	1800-B	Vacuum-Tube Voltmeter	126
1652-A	Resistance Limit Bridge	6	1800-P	Multipliers	127
1661-A	Vacuum-Tube Bridge	28	1862-B	Megohmmeter	130
1690-A	Dielectric Sample Holder	17	1931-B	Modulation Monitor	132
1690-P2	Adaptor Assembly	17	1932-A	Distortion and Noise Meter	227
1700	Variac® Speed Controls	222	1932-P1	A-M Detector Unit	228

	<i>Page</i>		<i>Page</i>
Absorption Modulator	92	Automatic Voltage Regulators	218-220
Ac Microvolter	131	Autotransformers, Variac®	199-217
Ac Power Supplies	135-140	Autotransformers, Variac®, Ganged	205-209, 211
Acoustical Instruments	171-194, 141	Autotransformers, Variac®, Metered	217
Adaptors, Coaxial	42, 241	Balanced Line Terminations	47
Adaptors, Sound-Level Meter	185	Balanced Modulator	92
Adjustable Attenuator, Coaxial	48	Balun	51
Adjustable Autotransformer, Variac®	199-217	Banana Plugs	240
Adjustable Lines and Stubs, Coaxial	46, 49	Bar Knobs	236
Adjustable Power Supply	136	Basic Connector, Coaxial	40
Admittance Meter, VHF	34	Basic Motor Speed Controls	221-223
Admittance Bridge, AF	24	Beat-Frequency Oscillators	74, 100-104
Air Capacitors		Binding Posts	238
Fixed, Two-Terminal	161	Bridges	1-37
Fixed, Three-Terminal	162	Ac Limit	26
Precision, Two-Terminal	158	Admittance	34, 36
Precision, Three-Terminal	158	Antenna-Measuring	30, 32, 34, 36, 52
Standard	161, 162	Capacitance	13-19
Variable	158, 230	Coaxial	34, 36
Air Line, Coaxial	46	Conductance	24, 34
Alligator Clip	239	De Limit	6, 8
A-M Detector	228	High-Resistance	8
A-M Monitor	132	Immittance	36
Amplifier, Audio-Frequency	60, 64	Impedance	22
Direct-Current	128	Impedance Comparison	26
Intermediate-Frequency	59	Inductance	20
Power	63	Insulation Resistance	8
Pulse	119	Megohm	8
Tuned	60	Radio-Frequency	30, 32
Amplitude Modulators	92	Reactance	30, 32
Amplitude-Regulating Power Supply	138	Resistance	6, 8
Analog Frequency Meter	83	Resistivity	8
Analizers, Continuous Spectrum	189, 225	Susceptance	24, 34
Harmonic	189, 225	Transfer-Function	36
Impact Noise	188	Transistor	28, 36
Noise	188-189, 191	UHF	34, 36
Octave-Band	191	Universal	22, 24
One-Third Octave	189	VHF	34, 36
Sound	189	Vacuum-Tube	28
Vibration	189	Z-Y	24
Wave	225	Bridge Amplifier	60
Distortion	227	Bridge Detectors	56-62
Antenna, Dummy	92	Bridge Guard Circuit	15
Antenna Measuring Equipment	30, 32, 34, 36, 52	Bridge Oscillator	108
Attenuators, Coaxial, Adjustable and Fixed	48	Bridge Transformer	237
Attenuator, Decade	153	Broad-Band Modulator	92
Audio-Frequency Bridges	13-28	Brushes, Replacement, for Variacs	202, 203, 211
Audio-Frequency Microvolter	131	Cable, Coaxial	44
Audio-Frequency Oscillators	74, 98-107	Cable, Tripod and Extension	185
Audio Generator, Beat-Frequency	100		
Automatic Dial Drive	144		





## TITLE

	<i>Page</i>		<i>Page</i>
Cable, Connectors, Coaxial . . . . .	41	Dials, Direct-Drive and Friction-Drive . . . . .	234
Calibrator, Frequency . . . . .	82	Gear-Drive, Precision . . . . .	234
Calibrator for Fuel-Gage Testers . . . . .	18	Dial Drives, Automatic Sweep . . . . .	144
Calibrator (Tester), Fuel-Gage . . . . .	171	Dial Drives with Horizontal Sweep . . . . .	146
Calibrator, Sound-Level . . . . .	187	Dial Plates, Potentiometer . . . . .	233
Calibrator, Time/Frequency . . . . .	82	Dielectric Measuring Bridge . . . . .	13-16
Calibrator, Vibration . . . . .	194	Dielectric Sample Holder . . . . .	17
Capacitance Bridges . . . . .	13-19	Digital Time and Frequency Meter . . . . .	76
Capacitors . . . . .	156-171	Digital-to-Analog Converter . . . . .	80
Capacitors, Air Dielectric . . . . .	161, 162	Diode Modulator, Crystal . . . . .	92
Decade . . . . .	168	Direct-Current Amplifier . . . . .	128
Fixed . . . . .	161, 163, 170	Discriminator, Frequency Meter and . . . . .	83
Mica Dielectric . . . . .	163, 170	Distortion and Noise Meter . . . . .	227
Paper Dielectric . . . . .	163, 170	Divider, Frequency . . . . .	70
Polystyrene Dielectric . . . . .	158-164, 166, 168	Divider, Voltage . . . . .	92, 154
Precision . . . . .	158-163	Drive, Dial . . . . .	144-146
Standard . . . . .	161-163	Drive, Sweep . . . . .	144
Three-Terminal . . . . .	158-165, 168-171	Drum Controller . . . . .	223
Two-Terminal . . . . .	158-171	Dummy Antenna . . . . .	92
Variable Air . . . . .	158	Dynamic Microphone Assembly . . . . .	186
Case for RF Bridge . . . . .	31		
Case for Sound-Level Meter . . . . .	183	Electrometer . . . . .	128
Case for Sound-Survey Meter . . . . .	181	Emergency Power Supply . . . . .	69
Case for Transistor Oscillator and Calibrator . . . . .	187		
Charts, Reactance . . . . .	244	Filters, Coaxial . . . . .	45
Smith . . . . .	55	High-Pass . . . . .	61
Chart Paper for Recorder . . . . .	143	Low-Pass . . . . .	45
Chokes (for Variacs) . . . . .	205	Frequency Counter, Digital . . . . .	76
Clip, Alligator . . . . .	239	Frequency Divider . . . . .	70
Cliplock, Coaxial . . . . .	43	Frequency Measuring Equipment . . . . .	74
Clock, Synchronous Motor . . . . .	71	Frequency Meters, Heterodyne . . . . .	74
Coaxial Elements . . . . .	39	Frequency Meter and Discriminator . . . . .	83
Coaxial Instruments . . . . .	34-37, 52	Frequency Multipliers . . . . .	72
Coaxial Patch Cords . . . . .	44	Frequency Oscillator . . . . .	70
Comparator, Impedance . . . . .	26	Frequency Standards . . . . .	68, 82
Comparison Bridges . . . . .	6, 26	Frequency Transfer Units . . . . .	74
Comparison Oscilloscope . . . . .	74	Friction-Drive Dials . . . . .	144-146
Component Mounts . . . . .	43, 129	Fuel-Gage Tester . . . . .	171
Component Shield . . . . .	129		
Condenser Microphone Systems . . . . .	184	Ganged Variac Autotransformers . . . . .	205-209, 211
Connectors, Coaxial . . . . .	40	Gear-Drive Dial . . . . .	146
Locking . . . . .	41	Generators . . . . .	85-106
Shielded . . . . .	41, 44	Beat-Frequency . . . . .	100, 104
Contact, Stroboscopic . . . . .	198	Pulse . . . . .	115, 116, 120
Control Box and Vibration Pickup . . . . .	185	Random-Noise . . . . .	123
Control, Remote, for Variacs . . . . .	216	Sine-Wave . . . . .	98-113
Controls, Motor Speed . . . . .	221-223	Square-Wave . . . . .	102, 115-118
Converter, Digital-to-Analog . . . . .	80	Standard-Frequency . . . . .	74
Cords, Patch . . . . .	44, 241	Standard-Signal . . . . .	85-91
Cords, Power . . . . .	241	Sweep . . . . .	116
Counter, Frequency . . . . .	76	Three-Phase . . . . .	96
Counting Decades . . . . .	81	Time-Delay . . . . .	116, 120
Coupling Elements, Coaxial . . . . .	43	Video . . . . .	104
Coupling Panel . . . . .	74	Graphic Level Recorder . . . . .	141
Crystal Diode Modulators . . . . .	92	Guard Circuit . . . . .	15
Data Printer . . . . .	78	Harmonic Analyzers . . . . .	189, 225
Db Tables . . . . .	245-250	Heterodyne Detectors . . . . .	58, 75
Decade Attenuator . . . . .	153	Heterodyne Frequency Meters . . . . .	74
Decade Capacitors . . . . .	168	High-Level Microphone . . . . .	184
Decade Inductors . . . . .	178	High-Pass Filter . . . . .	62
Decade Resistors . . . . .	149-153	High-Speed Light Source . . . . .	196, 197
Decade Switches . . . . .	152		
Decade Voltage Divider . . . . .	154	Immittance Bridge . . . . .	36
Decade Counting Units . . . . .	81	Impact Noise Analyzer . . . . .	188
Delay Generators, Time . . . . .	116, 120	Impedance Bridges . . . . .	22, 24
Delay Line, Variable . . . . .	122	Impedance Comparators . . . . .	26
Detector, Voltmeter . . . . .	50	Impedance Matching Transformer . . . . .	237
Detectors . . . . .	56-62	Inductance Bridge . . . . .	20
Heterodyne . . . . .	58		
Null . . . . .	58, 60, 62		





	<i>Page</i>		<i>Page</i>
Inductors . . . . .	172-178	Motor Speed Controls . . . . .	221-223
Decade . . . . .	178	Mounts, Transistor . . . . .	37
Fixed . . . . .	173, 176	Tube . . . . .	37
Standard . . . . .	173	Component . . . . .	23, 43
Variable . . . . .	175	Multipliers (for Vacuum-Tube Voltmeter) . . . . .	127
Insertion Loss Modulator . . . . .	92	Multipliers, Standard-Frequency . . . . .	72
Insulated Plugs . . . . .	240	Mutual Inductance Standard . . . . .	175
Insulators, Panel Terminal . . . . .	238		
Intermediate-Frequency Amplifier, Unit . . . . .	59	Noise Analyzers, Impact . . . . .	188
Interpolation Equipment . . . . .	74	Octave-Band . . . . .	191
Interpolation Oscillator . . . . .	74	One-Third Octave . . . . .	189
		Noise Generator, Random- . . . . .	123
Jacks and Plugs . . . . .	238, 240	Noise Meters . . . . .	182, 227
		Null Detector and Amplifier . . . . .	60
Kits, Cable Measuring . . . . .	54	Null Detector, Unit . . . . .	61
Slotted Line . . . . .	54	Null Detector, UHF-VHF . . . . .	58
Klystron Oscillator . . . . .	113		
Klystron Power Supply . . . . .	113	Octave-Band Noise Analyzer . . . . .	191
Knobs . . . . .	236	Oscillators, Audio . . . . .	74, 98-107
		Beat-Frequency . . . . .	74, 100, 104
Level Recorder, Graphic . . . . .	141	Bridge . . . . .	108
Limit Bridges . . . . .	6, 26	Four-Phase . . . . .	96
Resistance . . . . .	6	Interpolation . . . . .	74
Line, Delay . . . . .	122	Inverse Feedback . . . . .	98, 99
Slotted . . . . .	52	Klystron . . . . .	113
Variable Delay . . . . .	122	Low-Distortion . . . . .	98
Lines and Line Elements, Coaxial . . . . .	43, 46	Low-Frequency . . . . .	96
Locking Connectors . . . . .	40	Radio-Frequency . . . . .	107, 108
Loop, Test . . . . .	92	Resistance-Capacitance Tuned . . . . .	96, 98, 99, 102
Low-Distortion Oscillator . . . . .	98	Standard-Frequency . . . . .	70
Low-Frequency Oscillator . . . . .	96	Sweep Drive . . . . .	144-146
Low-Pass Filter . . . . .	45	Super-High-Frequency . . . . .	113
		Three-Phase . . . . .	96
Matched Terminations, Coaxial . . . . .	47	Transistor . . . . .	106
Mechanical Sweep Drives . . . . .	144-146	Ultra-High-Frequency . . . . .	109-112
Megohm Bridge . . . . .	8	Unit . . . . .	102-106, 107, 110-113
Megohmmeters . . . . .	128, 130	Variable Phase . . . . .	96
Mega-megohmmeter . . . . .	128	Very-High-Frequency . . . . .	109-112
Metered Variacs . . . . .	217	Oscilloscope, Comparison . . . . .	74
Meters, Admittance . . . . .	34	Output Power Meter . . . . .	134
Distortion and Noise . . . . .	227		
Digital Time and Frequency . . . . .	76	Pads, Attenuator . . . . .	48
Frequency and Discriminator . . . . .	83	Panel Terminal Insulator . . . . .	238
Megohm . . . . .	128, 130	Parts and Accessories . . . . .	229-241
Noise . . . . .	181	Patch Cords . . . . .	44, 241
Power . . . . .	134	Pickup, Vibration . . . . .	185
Sound-Level . . . . .	182	Plugs and Jacks . . . . .	238, 240
Sound-Survey . . . . .	181	Polyethylene Cable . . . . .	41
UHF Admittance . . . . .	34	Polyethylene Capacitors . . . . .	158-164, 166-169
Vacuum-Tube Voltmeter . . . . .	126	Potentiometers . . . . .	231
Vibration . . . . .	192	Potentiometer Dial Plates . . . . .	233
Micro-microammeter . . . . .	128	Power Amplifier . . . . .	63
Microphone Adaptor Plug . . . . .	185	Power Chokes . . . . .	205
Microphone Assembly, Dynamic . . . . .	186	Power Cords . . . . .	241
Microphone System, Condenser . . . . .	184	Power Meters, Output . . . . .	134
Microvoltmeter . . . . .	131	Power Supplies . . . . .	69, 135-140
Militarized Voltage Regulator . . . . .	220	Amplitude-Regulating . . . . .	138
Mixer Rectifier . . . . .	45	Klystron . . . . .	113
Modulating Power Supply . . . . .	139	Unit . . . . .	136, 137
Modulation Monitor, Amplitude . . . . .	132	Modulating . . . . .	139
Modulators, Amplitude . . . . .	92, 139	Precision Capacitor . . . . .	158-163
Balanced . . . . .	92	Precision Dials . . . . .	234
Crystal Diode . . . . .	92	Primary Frequency Standard . . . . .	68
Pulse . . . . .	92	Printer, Data . . . . .	78
Monitor, Amplitude-Modulation . . . . .	132	Pulse Amplifier, Unit . . . . .	119
Motor Drives, Dial . . . . .	144-146	Pulse Generators . . . . .	114-122
Motor Drive, Sweep . . . . .	144	Pulse, Sweep and Time-Delay Generators . . . . .	116
		Pulser, Unit . . . . .	115

# INDEX



## TITLE

	<i>Page</i>	<i>Page</i>	
Radio-Frequency Bridge . . . . .	30-33	Time/Frequency Calibrator, Unit . . . . .	82
Radio-Frequency Oscillator . . . . .	107, 108	Time and Frequency Meter, Digital . . . . .	76
Random-Noise Generator . . . . .	123	Toroidal Transformer . . . . .	237
R-C Oscillators . . . . .	96-98, 102	Transducer . . . . .	185
Reactance Charts . . . . .	244	Transfer-Function Bridge . . . . .	36
Receptacle, 3-Wire . . . . .	241	Transfer Units, Frequency . . . . .	74
Recorder, Graphic Level . . . . .	141	Transformers, Adjustable, Variac® . . . . .	199-217
Recorder Accessories . . . . .	143	Bridge . . . . .	237
Rectifier, Mixer . . . . .	45	Impedance Matching . . . . .	237
Rectifier, Voltmeter . . . . .	50	Shielded . . . . .	237
Regulated Power Supplies, Unit . . . . .	136, 137	Toroidal . . . . .	237
Regulating Power Supply, Amplitude . . . . .	138	VHF . . . . .	237
Regulators, Line Voltage . . . . .	218-220	Transistor Bridges . . . . .	28-36
Military . . . . .	220	Transistor Mounts . . . . .	37
Remote Control for Variacs . . . . .	216	Transistor Oscillator . . . . .	106
Resistance Bridge . . . . .	6, 8	Tripod and Extension Cable . . . . .	185
Resistance Meters, Megohm . . . . .	128, 130	Tube Mounts . . . . .	37
Resistors . . . . .	147-155	Tuned Amplifier . . . . .	60
Decade . . . . .	149-153	Tuned Circuit Filters . . . . .	62
Fixed . . . . .	155	Two-Terminal Capacitors . . . . .	158-171
Variable . . . . .	231		
Rheostat and Voltage Divider . . . . .	154, 231	UHF Admittance Meter . . . . .	34
Rigid Line Adaptors, Coaxial . . . . .	42, 51	UHF Coaxial Equipment . . . . .	34-54
		UHF Oscillators . . . . .	109-113
Sample Holder, Dielectric . . . . .	17	UHF Standard-Signal Generator . . . . .	85-91
Secondary Standard of Frequency . . . . .	82	Unit Instruments . . . . .	56-64, 82-83, 106-107, 110-113, 136-137
Shield, Component . . . . .	129	Universal Bridges . . . . .	22, 24
Shielded Transformer . . . . .	237		
Signal Generators, Standard- . . . . .	85-91	Vacuum-Tube Bridge . . . . .	28
Slotted Line . . . . .	52	Vacuum-Tube Voltmeter . . . . .	126
Smith Charts . . . . .	55	Variable Air Capacitor . . . . .	158
Sound Analyzers . . . . .	189	Variable Delay Line . . . . .	122
Sound-Level Calibrator . . . . .	187	Variable Inductor . . . . .	175
Sound-Level Meter . . . . .	182	Variable Power Supplies . . . . .	136
Sound-Survey Meter . . . . .	181	Variable Resistors . . . . .	231
Speed Controls, Variac Motor . . . . .	221-223	Variac® Autotransformers . . . . .	199-217
Square-Wave Generators . . . . .	102, 115-118	Metered . . . . .	217
Standards, Capacitance . . . . .	161-163	Motor Speed Controls . . . . .	221-223
Inductance . . . . .	173	Remote Control . . . . .	216
Mutual Inductance . . . . .	175	Voltage Regulators . . . . .	218-220
Primary Frequency . . . . .	68	Variometer . . . . .	175
Standard Frequency Multipliers . . . . .	72	VHF Coaxial Equipment . . . . .	38-54
Standard-Signal Generators . . . . .	85-93	VHF Oscillators . . . . .	109-112
Strobolum . . . . .	197	VHF Standard-Signal Generator . . . . .	86-91
Stroboscopes . . . . .	195-197	Vibration Analyzer . . . . .	189
Stroboscopic Contactor . . . . .	198	Vibration Calibrator . . . . .	194
Strobotac® . . . . .	196	Vibration Meter . . . . .	192
Strobolum . . . . .	197	Vibration Pickup . . . . .	185
Stubs, Coaxial . . . . .	49	Vibration Pickup System . . . . .	185
Supplies, Power . . . . .	69, 135-140	Video Generator . . . . .	104
Sweep Drives, Automatic . . . . .	144	Voltage Dividers . . . . .	92, 154, 231
Synchronous . . . . .	146	10:1 . . . . .	92
Sweep Oscillator . . . . .	104	Decade . . . . .	154
Sweep Generator, Pulse, and Time-Delay . . . . .	116	Rheostat . . . . .	231
Switch, Speed Control . . . . .	223	Voltage Regulators, Automatic . . . . .	218-220
Synonometer . . . . .	71	Military . . . . .	220
Synchronous Motor Clock . . . . .	71	Voltmeter, Vacuum-Tube . . . . .	126
		Voltmeter Detector . . . . .	50
Tachometer . . . . .	196	Voltmeter Indicator . . . . .	50
Terminations, Coaxial . . . . .	47	Voltmeter Rectifier . . . . .	50
Test Jig . . . . .	23	VSWR Meters . . . . .	34, 36, 52
Test Loop . . . . .	92	VTVM . . . . .	126
Tester, Fuel-Gage . . . . .	171		
Three-Terminal Capacitors . . . . .	158-165, 168-171	Wave Analyzers . . . . .	189, 225
Three-Wire Power Cord . . . . .	241	Waveform-Measuring Instruments . . . . .	225-228
Three-Wire Receptacle . . . . .	241		
Time-Delay Generators . . . . .	116, 120	Z-Y Bridge . . . . .	24
Time-Delay, Pulse, and Sweep Generator . . . . .	116		
Time-Base Units . . . . .	81		

# EXPORT REPRESENTATIVES

## AUSTRALIA

WARBURTON FRANKI INDUSTRIES PTY., LTD.  
Instruments Division  
307-315 Kent Street  
Sydney, N.S.W., Australia  
Phone BX1111, Cable: BOOSTER  
Offices: Melbourne, Brisbane, Adelaide

## BELGIUM

S. A. MULTITECHNIC  
30, Place Saintelette  
Bruxelles 8, Belgique  
Tél.: 25.16.36, Télégr.: MULTITECHNIC

## CANADA

(See inside  
front cover)

## DENMARK

SEMLER & MATTHIASSEN  
22, Teglværsgade  
København Ø, Danmark  
Tel: \*29 03 11, Telgr.: SEMMATT

## EGYPT

MR. MOUSTAPHA EZZAT ABDEL WAHAB  
106, Mohamed Bey Farid Street  
P.O.B. 1537  
Cairo, Egypt, U.A.R.  
Tel.: 77352, Cables: TULIP

## FINLAND

K. L. NYMAN  
11 Meritullinkatu  
Helsinki, Finland  
Tel.: 66 39 09, Cables: KLNMYAN

## FRANCE

Ets. RADIOPHON  
148, Avenue Malakoff  
Paris 16, France  
Tél.: KLEBER 32 50, Cable: RADIOPHON-PARIS

RADIOPHON CORPORATION  
509 Madison Avenue  
New York 22, New York

## GERMANY

DR. -ING. GÜNTER NÜSSLEIN  
Dörnigweg 6, Postfach 42  
Ettlingen/Karlsruhe,  
Bundesrepublik Deutschland  
Tel.: ETTLINGEN 2566

## GREECE

K. KARAYANNIS  
Karitsi Square  
Athens, Greece  
Tel.: 23.213, Cable: RAKAR

## INDIA

MOTWANE PRIVATE LIMITED  
127 Mahatma Gandhi Road  
P.O.B. 1312, Fort  
Bombay 1, India  
Tel.: 252337, Telgr.: CHIPHONE  
Branches in: Calcutta, Lucknow, Kanpur, New Delhi,  
Madras, Bangalore, and Secunderabad

## ISRAEL

EASTRONICS LTD.  
22 Maze Street  
P.O.B. 2554  
Tel Aviv, Israel  
Phone: 66890, Cables: EASTLAND

LANDSEAS PRODUCTS CORPORATION  
48 West 48th Street  
New York 36, New York

## ITALY

ING. S. & DR. GUIDO BELOTTI  
Piazza Trento 8  
Milano (718), Italia  
Tel.: 54.20.51, Telegr.: INGBELOTTI  
Uffici: Genoa, Roma, Napoli

## JAPAN

MIDORIYA ELECTRIC CO., LTD.  
3, 2-Chome, Kyobashi  
Chuo-ku, Tokyo, Japan  
Tel.: 561-9256, Cables: MIDRIYAEL

## LATIN AMERICA

AD. AURIEMA, INC.  
85 Broad Street  
New York 4, New York  
Cables: AURIEMA, Telex: 2791 NEW YORK  
Resident representatives in principal cities  
of South America, Central America, Mexico,  
and the Caribbean Area.

## NETHERLANDS

TECHNISCH VERKOOPKANTOOR GROENPOL  
13-15 Prinsengracht  
Postbus 1188  
Amsterdam, Holland  
Tel. 64474, Telegr.: GROENPOL  
Telex: 11177

## NEW ZEALAND

W. & K. McLEAN LTD.  
7 Anzac Avenue  
P.O.B. 3097  
Auckland, New Zealand  
Phone: 34-541, Cables: KOSFY

## NORWAY

MASKIN-AKTIESELSKAPET ZETA  
Drammensveien 26  
Postboks 2492 5  
Oslo, Norway  
Tel.: 44 18 55, Telegr.: MASKINZETA  
Telex: 1157

## REPUBLIC OF SOUTH AFRICA

ROGERS-JENKINS AND CO. (PTY) LTD.  
249 Main Street  
P.O.B. 3762  
Johannesburg, Republic of South Africa  
Phone: 22-4402, Cables: TEMPUS  
Telex: JX308

## SPAIN and PORTUGAL

AD. AURIEMA, INC.  
85 Broad Street  
New York 4, New York  
Cables: AURIEMA, Telex: 2791 NEW YORK  
Resident representatives in Madrid and Lisboa

## SWEDEN

JOHN C. LAGERCRANTZ  
Värtavägen 57  
Stockholm, Sweden  
Tel.: 63 07 90, Cable: FIVESSVEE

## SWITZERLAND

SEYFFER & COMPANY, INC.  
Badenerstrasse 265  
Zürich, Schweiz  
Tel: 25 54 11, Telegr.: RADIOSEYFFER

## TURKEY

MEHMET VASFI MÜESSESESI  
Galata, Bankalar Cad. 71-73  
P.O.B. 143  
Istanbul, Turkey  
Tel.: 447590, Cables: VASFI

## UNITED KINGDOM

CLAUDE LYONS, LTD.  
Valley Works  
Hoddesdon, Herts, England  
Tel.: 4541, Telegr.: MINMETKEM HODDESODON TELEX  
Telex: 22724

CLAUDE LYONS, LTD.  
76 Old Hall Street  
Liverpool 3, England



## CATALOG Q

GENERAL RADIO COMPANY  
WEST CONCORD MASSACHUSETTS

*District Offices* • NEW YORK • PHILADELPHIA  
CHICAGO • WASHINGTON • LOS ANGELES  
SAN FRANCISCO • TORONTO

*(See Inside Cover)*

REPRESENTATIVES IN PRINCIPAL COUNTRIES

*(See Inside Back Cover)*

