

OPERATING INSTRUCTIONS



TYPE 1201-C

**UNIT REGULATED
POWER SUPPLY**

G E N E R A L R A D I O C O M P A N Y



File Courtesy of GRWiki.org



Figure 1-1. Panel view of the Type 1201-C Unit Regulated Power Supply. The Type 1201-CQ18 is identical in appearance except for type number and input data silk-screening.

SPECIFICATIONS

Input: Type 1201-C – 105 to 125 volts; Type 1201-CQ18 – 195 to 235 volts or 210 to 250 volts; 50 to 60 cps, 90 watts full load nominal line voltage. Also can be operated from 400-cycle supply if 400-cycle, 6.3 volt output can be tolerated.

Output: 300 volts dc regulated at 70 milliamperes maximum; 6.3 volt ac unregulated at 4 amperes maximum.

Regulation: $\pm 0.25\%$ with maximum line and load variations combined

Ripple: Less than 1 millivolt, rms, 120 cps, at full load.

Connectors: Three-wire cord permanently attached. Standard 4-terminal receptacle mounted on cabinet side for convenient connection to Unit instruments.

Accessories Supplied: Mating plug for equipment other than Unit instruments.

Cabinet: Unit instrument.

Dimensions: Width 5, height $5\frac{3}{4}$, depth $6\frac{1}{4}$ inches (130 by 150 by 160 mm), over-all, not including power cord.

Net Weight: 6 pounds (2.8 kg).

Shipping Weight: 11 pounds (5 kg).

1. INTRODUCTION.

1.1 PURPOSE AND DESCRIPTION.

The Types 1201-C and 1201-CQ18 Unit Regulated Power Supplies (Figure 1-1) are designed to provide a source of regulated power for other Unit instruments. They can also supply instruments other than those of the Unit line by means of a mating connector provided.

Both power supplies provide 300 volts dc at a maximum of 70 milliamperes and 6.3 volts ac at a maximum of 4 amperes. They are recommended in applications that require low ripple voltage and constant input voltage.

2. OPERATING PROCEDURE.

2.1 RELAY-RACK MOUNTING.

If desired, the Type 1201-C can be rack-mounted by use of the appropriate adaptor panel as listed in Table 2-1. The panels are finished in charcoal-gray crackle paint to match the instrument panel.

**TABLE 2-1
RELAY-RACK ADAPTOR PANELS**

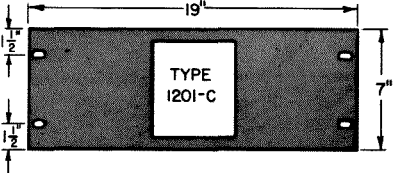
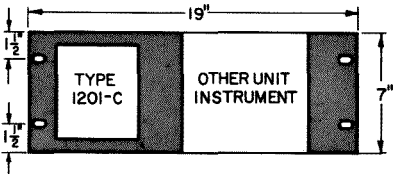
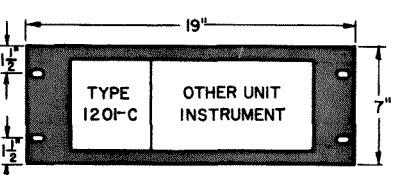
Type	Description	Code Number
<p style="text-align: center;">480-P4U1</p> 	<p>Relay-Rack Adaptor Panel used to rackmount the Type 1201-C alone.</p>	<p style="text-align: center;">0480-9984</p>
<p style="text-align: center;">480-P4UCS1</p> 	<p>Relay-Rack Adaptor Panel used to rackmount the Type 1201-C with a Type 1208-C, 1209-C, 1209-CL, 1211-C, 1215-C, or 1361-A.</p>	
<p style="text-align: center;">480-P4U3</p> 	<p>Relay-Rack Adaptor Panel used to rackmount the Type 1201-C with a Type 1206-B, 1210-C, 1212-A, 1213-D, 1217-C, or 1220-A.</p>	<p style="text-align: center;">0480-9986</p>

2.2 AC-LINE CONNECTIONS.

The Type 1201-C is wired to operate from an ac line of 105 to 125 volts. The Type 1201-CQ18 is normally wired to operate from an ac line of 195 to 235 volts but it can be changed to operate from 210 to 250 volts as follows (see Figure 2-1):

- a. Locate the three connections to the primary of the power transformer, T1 (all three are on the front of the transformer, toward the outside edge).
- b. For 210 to 250-volt operation, move the red lead from the lower primary tab to the upper one.

2.3 INTERUNIT CONNECTIONS.

If the power supply is to be used with a Unit instrument, plug the Unit instrument into the four-terminal connector (SO1, shown in Figure 2-2) on the right-hand side of the power supply.

If the power supply is to be used with equipment other than Unit instruments, use the mating connector provided. Terminal numbers are shown in Figure 2-2 and are also marked on the socket.

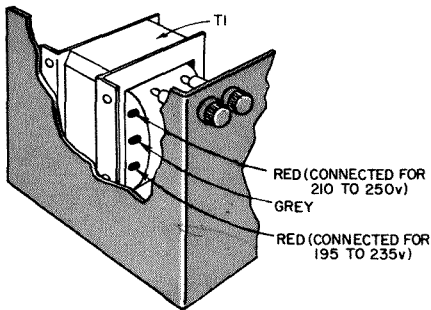

Figure 2-1. To change ac line requirements of Type 1201-CQ18, interchange red wire on power transformer.

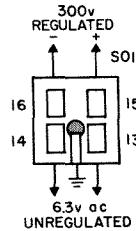

Figure 2-2. Power output connector. Both the 6.3-volt ac and the 300-volt dc supplies are isolated from ground to give greater latitude in external connections.

3. PRINCIPLES OF OPERATION.

3.1 GENERAL.

A full-wave voltage doubler with silicon rectifiers provides the input voltage for the series regulator. The output voltage, through a voltage divider, is compared with a zener reference diode by means of a cascode amplifier. The amplified error voltage controls the series regulator tube to provide constant output voltage. An additional feedback loop, comprising R533, R538, and R531, reduces the effects of input fluctuations.

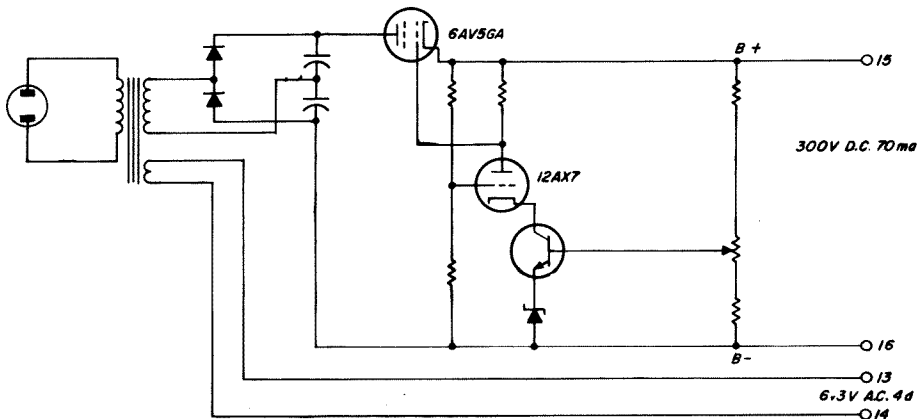

Figure 3-1. Elementary schematic diagram of the Type 1201-C and Type 1201-CQ18 Unit Regulated Power Supplies.

4. SERVICE AND MAINTENANCE.

4.1 WARRANTY.

We warrant that each new instrument sold by us is free from defects in material and workmanship, and that, properly used, it will perform in full accordance with applicable specifications for a period of two years after original shipment. Any instrument or component that is found within the two-year period not to meet these standards after examination by our factory, sales engineering office, or authorized repair agency personnel, will be repaired or, at our option, replaced without charge, except for tubes or batteries that have given normal service.

4.2 SERVICE.

The two-year warranty stated above attests the quality of materials and workmanship in our products. When difficulties do occur, our service engineers will assist in any way possible. If the difficulty cannot be eliminated by use of the following service instructions, please write or phone our Service Department (see rear cover), giving full information of the trouble and of steps taken to remedy it. Be sure to mention the serial and type numbers of the instrument.

Before returning an instrument to General Radio for service, please write to our Service Department or nearest sales engineering office, requesting a Returned Material Tag. Use of this tag will ensure proper handling and identification. For instruments not covered by the warranty, a purchase order should be forwarded to avoid unnecessary delay.

4.3 OUTPUT VOLTAGE ADJUSTMENT.

A single adjustment, R542 (Figure 4-1), is provided to set the output voltage to 300 volts $\pm 1\%$. Readjustment of this potentiometer is usually unnecessary, except after replacement of CR534 (type IN758A zener diode). Adjust R542 so that an accurate voltmeter indicates 300 volts at the output terminals.

4.4 FUSES.

The Type 1201-C Unit Regulated Power Supply uses 0.8-ampere fuses. When the power supply is used with Unit instruments, full output power is not required and the input current is below 0.8 ampere. However, if both output voltages are fully loaded and the power supply is run on a 125-volt line, the input current is just over 0.8 amperes and the fuses may blow after several hours. Therefore, substitute 1-ampere fuses for continuous operation at high line voltage and full load.

The Type 1201-CQ18 Unit Regulated Power Supply uses 0.5 ampere fuses which are satisfactory for all normal line and load conditions.

4.5 COVER REMOVAL.

To remove the cover, loosen the thumbscrew on the left-hand side of the cabinet and slide the cover off, away from the panel.

4.6 ETCHED-BOARD REMOVAL.

While it is possible to replace all tubes and measure all voltages without removal of the etched board, access to components requires swinging the etched board out of the instrument. Remove V531 (6AV5GA) and the two screws at the rear of the etched board (see Figure 4-1). The board will now swing out on the hinges provided. If V531 is replaced, the instrument may be operated in this position.

4.7 TROUBLE-SHOOTING NOTES.

All voltages are measured with nominal ac line voltage unless noted otherwise (i.e., 115, 215, or 230 volts; refer to paragraph 2.2 for additional details).

4.7.1 INCORRECT OUTPUT VOLTAGE.

If the output voltage is regulated and within a few volts of 300, reset R542 (refer to paragraph 4.3). If this adjustment drifts, replace R540, R541, R542, or CR534.

If the output voltage drops only at low line and full load, replace V531 (6AV5GA) and check the voltage across C1 and C2. The voltage from the positive terminal of C2 to the negative terminal of C1 should be 430 volts with full load and nominal line voltage. If this voltage is less than 420 volts, check CR532, CR533, C1, and C2.

4.7.4 HIGH OUTPUT VOLTAGE.

If the output voltage is greater than 300 volts and completely unregulated, replace V532 (12AX7). If the tube is not defective, transistor Q531 may be open. Measure the voltages at key points with a vacuum-tube voltmeter, and compare them with those given on the schematic diagram, Figure 4-2.

4.7.5 EXCESSIVE RIPPLE.

120-cycle ripple. Measure the output ripple at full load. If it is excessive only at low line voltage, replace V531 (6AV5GA). If the voltage from the negative terminal of C1 to the positive terminal of C2 is less than 420 volts at full load and nominal line voltage, replace RX1 and RX2. If the ripple across C1 and C2 is greater than 6 volts peak-to-peak (2 volts rms) replace C1 and C2. If the output ripple is excessive at all line voltages, replace V531 (6AV5GA) and check resistors R538, R533, and R534.

60-cycle ripple. If the 60-cycle ripple is excessive only at full load, one rectifier (CR532 and CR533) or one capacitor (C1 or C2) may be faulty. If the ripple is independent of the load, it may be caused by a heater-cathode short in V532 (12AX7) or V531 (6AV5GA).

4.7.2 NO OUTPUT VOLTAGE.

Check V531 (6AV5GA). Measure the regulator input voltage from the negative terminal of C1 to the positive terminal of C2. If this input voltage is zero, check for a shorted CR532, CR533, C1, C2, and a blown fuse in the primary circuit of T1. If the input voltage is normal (430-500 v), check V532 (12AX7) for an internal short. Check Q531 for a short. Measure the voltages at key points with a vacuum tube voltmeter, comparing them with those given in Figure 4-2.

4.7.3 LOW OUTPUT VOLTAGE.

If the output voltage is 250 volts or less, measure the regulator input voltage from the negative terminal of C1 to the positive terminal of C2. If this voltage is greater than 400 volts, check R540, R541, R542, and CR534. If the regulator input voltage is less than 250 volts, check CR532, CR533, C1, and C2.

NOTE UNLESS SPECIFIED

1. POSITION OF ROTARY SWITCHES SHOWN COUNTERCLOCKWISE.
2. CONTACT NUMBERING OF SWITCHES EXPLAINED ON SEPARATE SHEET SUPPLIED IN INSTRUCTION BOOK.
3. REFER TO SERVICE NOTES IN INSTRUCTION BOOK FOR VOLTAGES APPEARING ON DIAGRAM.
4. RESISTORS 1/2 WATT.
5. RESISTANCE IN OHMS
K 1000 OHMS M 1 MEGOHM
6. CAPACITANCE VALUES ONE AND OVER IN PICO FARADS, LESS THAN ONE IN MICROFARADS.
7. ○ KNOB CONTROL
8. ⊕ SCREWDRIVER CONTROL
9. AT ANCHOR TERMINAL
10. TP - TEST POINT

* DEPEND ON CR534 (±5%)
VOLTAGES MEASURED BY VTVM
WITH RESPECT TO B- NO LOAD
LINE 115V (230V)
★ FULL LINE VOLTAGES
ANCHOR TERMINALS USED: A.T.531

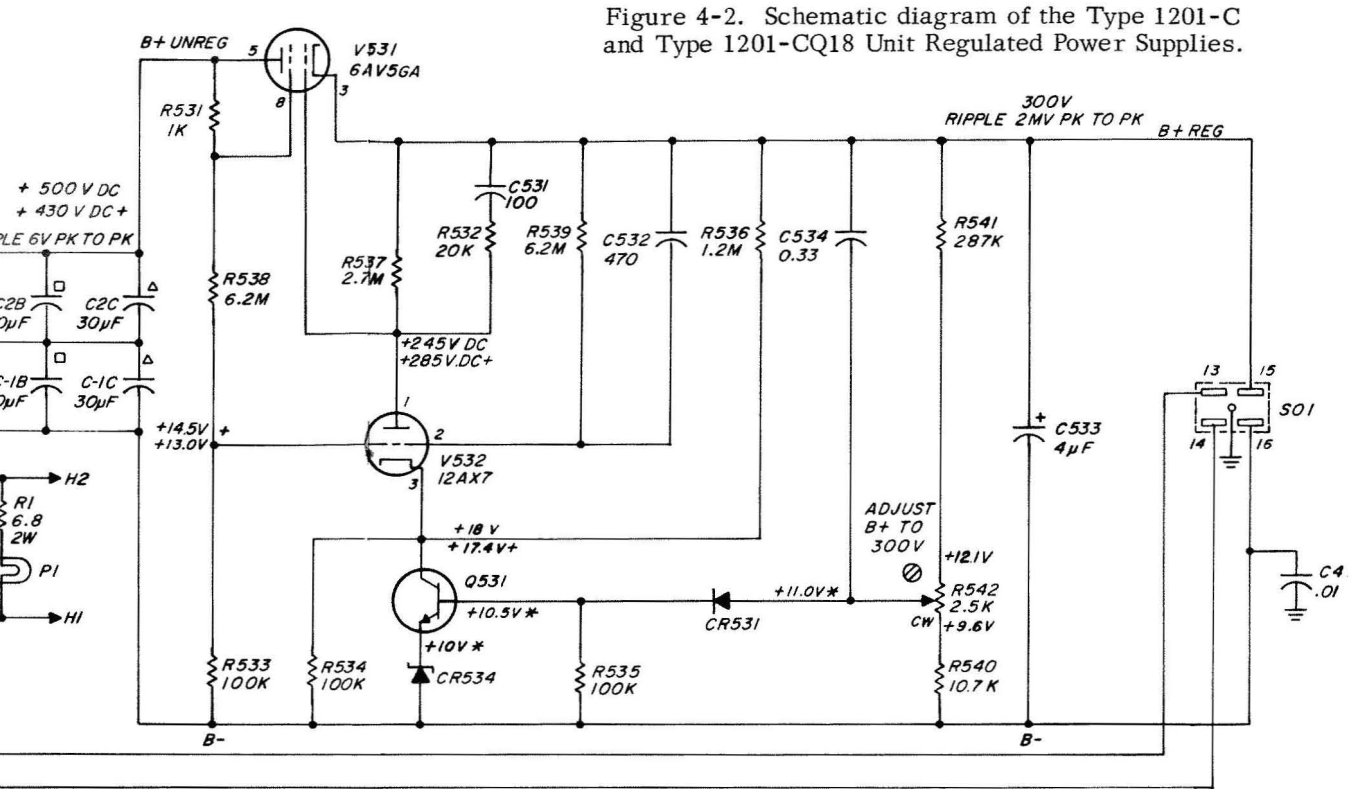
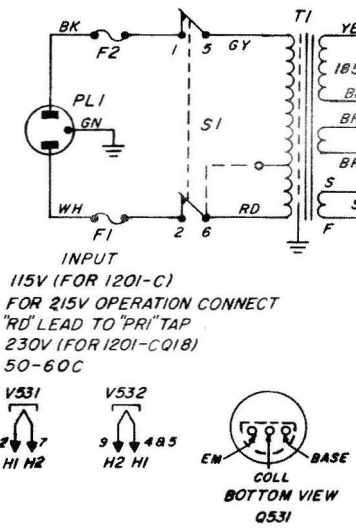

Figure 4-2. Schematic diagram of the Type 1201-C and Type 1201-CQ18 Unit Regulated Power Supplies.

PARTS LIST

Ref No.	Description	Part No.	Ref No.	Description	Part No.
C1 A, B, C	CAPACITOR, Electrolytic, 90 x 30 x 30 µf 300v	4450-3400	R1	RESISTOR, Wire-wound, 6.8 Ω ±10%	part of 7510-1930
C2 A, B, C	CAPACITOR, Electrolytic, 90 x 30 x 30 µf 300v	4450-3400	R531	RESISTOR, Composition, 1 kΩ ±5% 1/2w	6100-2105
C4	CAPACITOR, Ceramic, 0.01 µf ±20% 500v	4406-3109	R532	RESISTOR, Composition, 20 kΩ ±5% 1/2w	6100-3205
C531	CAPACITOR, Ceramic, 100 pf ±10%	4404-1108	R533	RESISTOR, Composition, 100 kΩ ±5% 1/2w	6100-4105
C532	CAPACITOR, Ceramic, 470 pf ±10%	4404-1478	R534	RESISTOR, Composition, 100 kΩ ±5% 1/2w	6100-4105
C533	CAPACITOR, Electrolytic, 4 µf 475v	4450-2000	R535	RESISTOR, Composition, 100 kΩ ±5% 1/2w	6100-4105
C534	CAPACITOR, Plastic, 0.33 µf ±10% 400v	4860-9700	R536	RESISTOR, Composition, 1.2 MΩ ±5% 1/2w	6100-5125
CR531	DIODES, Type 1N3254	6081-1002	R537	RESISTOR, Composition, 2.7 MΩ ±5% 1/2w	6100-5275
CR532	DIODES, Type 1N3255	6081-1003	R538	RESISTOR, Composition, 6.2 MΩ ±5% 1/2w	6100-5625
CR533	DIODES, Type 1N3255	6081-1003	R539	RESISTOR, Composition, 6.2 MΩ ±5% 1/2w	6100-5625
CR534	DIODES, Type 1N758A zener	6083-1012	R540	RESISTOR, Metal film, 10.7 kΩ ±1% 1/2w	6450-2107
F1	FUSE, for Type 1201-C, 0.8 amp 3AG slo-blo	5330-1200	R541	RESISTOR, Metal film, 287 kΩ ±1% 1/2w	6450-3287
F2	FUSE, for Type 1201-C, 0.8 amp 3AG slo-blo	5330-1200	R542	RESISTOR, Wire-wound, 2.5 kΩ ±10%	6050-1500
F1	FUSE, for Type 1201-CQ18, 0.5 amp 3AG slo-blo	5330-1000	S1	SWITCH, dpst, POWER	7910-1300
F2	FUSE, for Type 1201-CQ18, 0.5 amp 3AG slo-blo	5330-1000	SO1	SOCKET, Receptable, four-terminal	4230-0700
P1	PILOT LIGHT, Mazda 44, 6.3v 0.25 amp bayonet	5600-0700	T1	TRANSFORMER, for Type 1201-C	0485-4950
Q531	TRANSISTOR, Type 2N2714	8210-1047		TRANSFORMER, for Type 1201-CQ18	0485-4982
			V531	TUBE, Type 6AV5-GA	8360-2390
			V532	TUBE, Type 12AX7	8370-0900

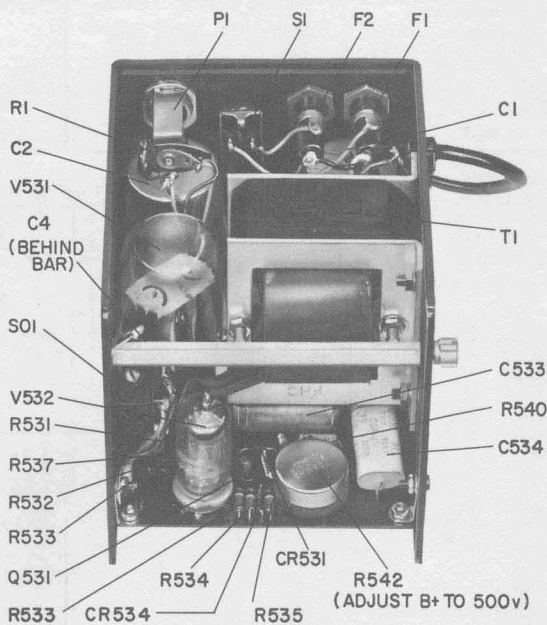
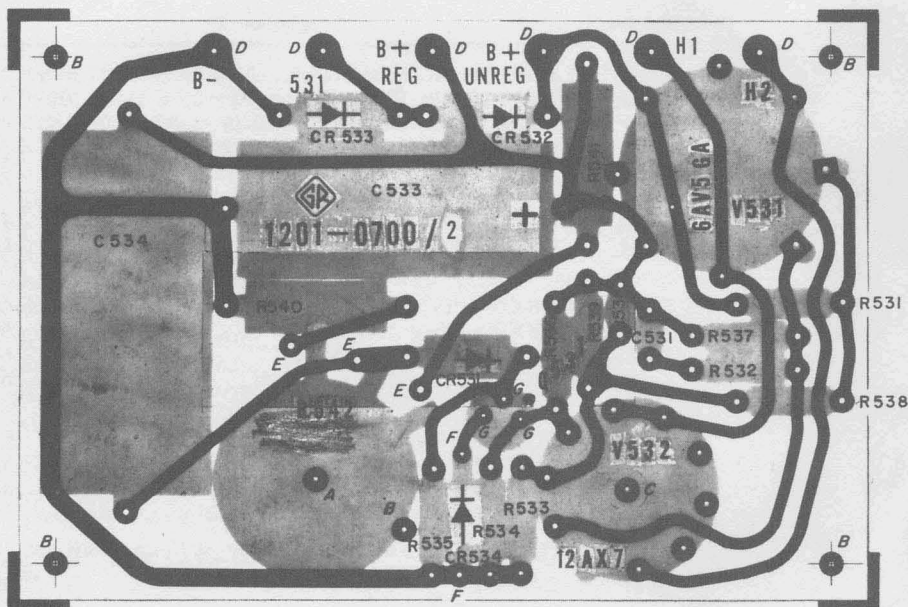

Figure 4-1. Interior view and etched-board layout.



WEST CONCORD, MASSACHUSETTS,* 01781

617 369-4400

617 646-7400

SALES ENGINEERING OFFICES

METROPOLITAN NEW YORK*

*Broad Avenue at Linden
Ridgefield, New Jersey, 07657
Telephone N.Y. 212 964-2722
N.J. 201 943-3140*

SYRACUSE

*Pickard Building
East Molloy Road
Syracuse, New York, 13211
Telephone 315 454-9323*

PHILADELPHIA

*1150 York Road
Abington, Pennsylvania, 19001
Telephone 215 887-8486
Phila., 215 424-7419*

WASHINGTON* AND BALTIMORE

*Rockville Pike at Wall Lane
Rockville, Maryland, 20852
Telephone 301 946-1600*

ORLANDO

*113 East Colonial Drive
Orlando, Florida, 32801
Telephone 305 425-4671*

* Repair services are available
at these district offices.

CHICAGO*

*6605 West North Avenue
Oak Park, Illinois, 60302
Telephone 312 848-9400*

CLEVELAND

*5579 Pearl Road
Cleveland, Ohio, 44129
Telephone 216 886-0150*

LOS ANGELES*

*1000 North Seward Street
Los Angeles, California, 90038
Telephone 213 469-6201*

SAN FRANCISCO

*1186 Los Altos Avenue
Los Altos, California, 94022
Telephone 415 948-8233*

DALLAS

*2501-A West Mockingbird Lane
Dallas, Texas, 75235
Telephone 214 Fleetwood 7-4031*

TORONTO*

*99 Floral Parkway
Toronto 15, Ontario, Canada
Telephone 416 247-2171*

MONTREAL BRANCH

*Office 395, 1255 Laird Boulevard
Town of Mount Royal, Quebec, Canada
Telephone 514 737-3673, -3674*

General Radio Company (Overseas), Zurich, Switzerland
General Radio Company (U.K.) Limited, Bourne End, Buckinghamshire, England
Representatives in Principal Overseas Countries

Printed in USA

