

Catalog E
Laboratory Apparatus



GENERAL RADIO COMPANY
CAMBRIDGE, MASSACHUSETTS

SECOND EDITION

DECEMBER, 1928.

Printed in U. S. A.





FOREWORD

Commercial acceptability has been the primary thought in the design of General Radio instruments. This should not be taken to mean that they are not precision instruments and, accordingly, lack accuracy, but rather that unusual ruggedness has been incorporated in their design. They have been designed to stand ordinary commercial laboratory use, without loss of accuracy.

A general classification of all instruments as laboratory working standards would, of course, be impractical. The very nature of some instruments as reference standards makes it necessary to give special attention to their precision. Even in these instruments, the construction is such that they may be referred to regularly, without the danger of injury to their accuracy of calibration.

A feature of particular interest in our line of laboratory equipment is the special parts that are available for quick laboratory set-ups. These parts consist of quick change-over switches, special plug and jack combinations, and bottle-neck binding posts. In a laboratory equipped with a few of these accessories it is possible to get along with a smaller number of instruments than would be required if permanent set-ups were used. This class of equipment will be found particularly useful where comparisons are being made between different kinds of instruments.

In looking through this catalog it is evident at once that the instruments listed are largely specialized ones for measurements at audio and radio frequencies. The fact, however, should not be lost sight of that many of these instruments are also particularly adapted for use at commercial frequencies and in direct current work.

Aside from the items listed in this catalog, we manufacture a large number of special instruments and pieces of apparatus. These are built either to the customer's specifications or to meet his particular requirements. Your problems in this field are solicited.



SHIPMENT and TERMS

Unless specific shipping instructions accompany an order, we will use our best judgment as to the method of shipment. All prices are F. O. B. Cambridge, Mass. There is no domestic packing charge and no charge for shipping cases unless so stated with the price of the instrument.

When ordering by telegraph, please specify quantity and our code word. Foreign customers will find it convenient to use Bentley's Code. Our cable address is Genradco, Boston.

Terms are net thirty days or with 2% discount for payment within ten days from date of shipment. When cash accompanies the order, we will pay transportation charges anywhere in the United States or Canada in place of allowing the usual cash discount.

Unless credit has already been established we will make shipments C. O. D.

A ONE PRICE POLICY

The items listed in this catalog are of such a nature that they are best distributed on a direct from manufacturer to consumer basis. Therefore, with the exception of a co-operative plan with the Central Scientific Company, of Chicago, Illinois, our instruments are not sold through dealers or brokers.

Many of the instruments require special engineering correspondence to determine their adaptability to the particular conditions of the prospective user. As these problems are strictly of an engineering nature, we maintain an engineering staff to give particular attention to such problems. Your correspondence is solicited.

As our instruments are not sold through dealers, prices have been made on a basis that does not permit any discount. All prices are, therefore, strictly net. Quantity discounts as given in the next paragraph are the only discounts allowed.

When ten to nineteen of any item are ordered at the same time for a single shipment, there is a 5% discount. In quantities of twenty to ninety-nine, the discount is 10%. In quantities of one hundred or over, special prices will be quoted on request.

Unless otherwise stated, quotations remain open for thirty days. Delivery promises are made subject to the usual classification of causes beyond our control. Catalog prices have been revised to December 1, 1928, but are subject to change without notice.

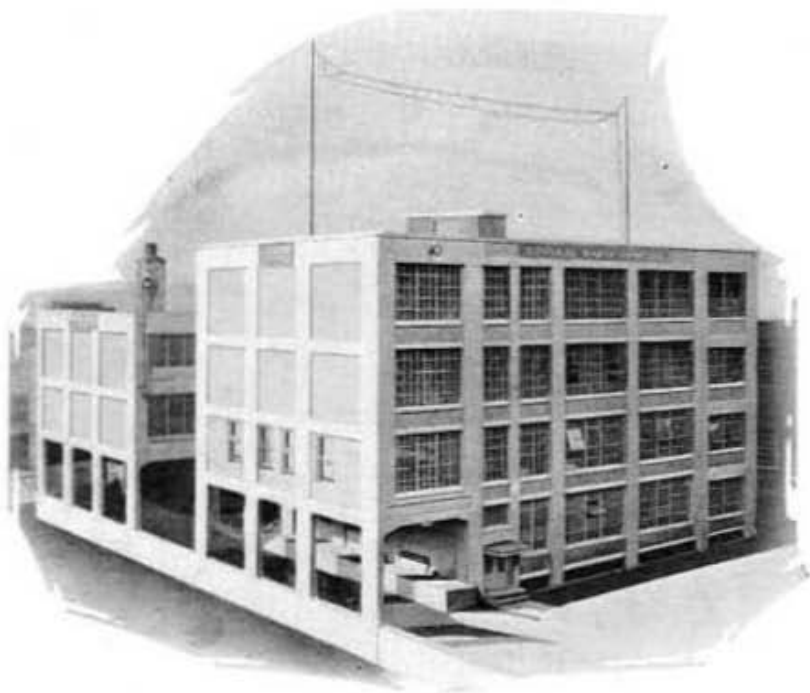

CONDENSERS

The requirements of communications laboratories have called for a wide variety of capacity units. These include precision units for capacity and frequency standards, and units for tuning of oscillator and filter circuits. The latter requirements alone necessitate a variety of condensers not only because of the wide frequency ranges in general use, but also because of the variety of operating conditions.

The larger capacities required for low frequency circuits are necessarily of paper or mica dielectric since air condensers of such capacity would involve great bulk.

TYPE 219 DECADE CONDENSERS



Every college and research laboratory has need of a variable condenser of large capacitance and reasonable accuracy for temporary set-ups where it is inexpedient to use the precision types. For maximum utility and rapidity of adjustment this unit should have the same flexibility as the familiar dial-decade type of resistance box.

In the Type 219 Decade Condenser this highly desirable feature is obtained by means of a cam switch which makes a definite contact with the successive units, determined by a ball and socket locking combination.

GENERAL RADIO COMPANY

This permits the construction of a unit possessing the same characteristics as the standard dial-decade type of resistance box. The capacitance in microfarads is read directly opposite the end of the switch pointer. The complete unit is mounted in a walnut case with bakelite panel.

The condensers used in the 0.001 steps are the mica type. Rolled, paraffin-impregnated paper condensers are used in the higher capacitance steps. While this type of condenser is inferior to that using mica dielectric, a well built paper condenser is so satisfactory for a wide variety of laboratory uses that the expense of the mica type in the larger capacitances is seldom justified. These units are supplied adjusted to within 5% in the 0.001 MF., and within 2% in the 0.01 MF. and 0.1 MF. steps, which is a fair indication of their constancy under various conditions of temperature and frequency.

The rolled paper condensers used in the Type 219 units represent the best of their type. The paper and foil are fed from the rolls through an impregnating bath of molten paraffin. The thorough impregnation thus obtained not only increases the dielectric strength, but also makes the unit more consistent in its behavior, due to its greater homogeneity. Sufficient overlap is allowed on the foil so that the successive layers of each plate may be bent over for contact with each other. Connection is made to the side of the plate, that is, to all layers in the roll. Because of its lower resistance, this method of assembly is much superior for laboratory and filter work to that which makes use of a connection at the ends of the plates only. The side connection also avoids the increase of phase angle with frequency which occurs with the end connection. The phase angle of these condensers at 1000 cycles is approximately 1%.

The completed condenser units are sealed in metal cans when finally mounted. A rigid moisture-proof assembly is thus assured.

The voltage rating of all units is 300 volts (D.C.).

USES. The Type 219 Decade Condenser is extremely useful in vacuum-tube oscillators of variable frequency. It provides the large capacitance required for low frequency, and provides convenient variation over a capacitance range of 1000 to 1. It is also useful in temporary filter set-ups and in tuning circuits to low frequencies.

Type 219-F Decade Condenser.....Price \$40.00

Ten 0.1 MF. steps.

Ten 0.01 MF. steps.

Dimensions $9\frac{1}{2}$ " x 5" x $5\frac{3}{4}$ ". Weight $5\frac{1}{4}$ lbs.

Code Word: COVER.

[6]



GENERAL RADIO COMPANY

Type 219-G Condenser.....Price \$60.00

Ten 0.001 MF. steps.

Ten 0.01 MF. steps.

Ten 0.1 MF. steps.

Dimensions $12\frac{3}{4}$ " x 5" x 6". Weight 7 lbs.

Code Word: BRIER.

— OO —

AIR CONDENSERS

Variable air condensers are generally used as secondary standards for all laboratory purposes for capacitances up to several thousandths microfarad. Condensers for this purpose must first of all be of such rugged mechanical construction as to withstand the handling of ordinary laboratory use, without suffering changes in calibration. It is also important that the phase angle be as low as is consistent with physical strength and that the field through the dielectric remain substantially constant with changes in capacity.

Realizing that there is an economic as well as a physical problem involved, the General Radio Company has divided its laboratory air condensers into three classes, designed to meet different requirements of precision and constancy. The Type 222 Precision Condenser is designed for use as a laboratory standard and in precision wavemeters. Where laboratory work of less exacting character is planned, the Type 246 or the Type 239 Variable Air Condenser will be found satisfactory. All three types are alike in general electrical design.

TYPE 222 PRECISION CONDENSER

Condensers used as standards and for precision measurements must have many features not usually found in ordinary laboratory condensers. For variable standards it is essential that the plates be sufficiently rigid and well spaced so that handling the condenser will not cause a change in capacitance. It is not alone sufficient that the power factor be low, but it is also important that the dielectric losses be substantially constant throughout the entire range of the condenser.

GENERAL RADIO COMPANY

The General Radio Type 222 Precision Condenser is intended for use where precision is essential, rather than for use as an ordinary laboratory experimental condenser. In its design, the mechanical as well as the electrical features have received special attention.

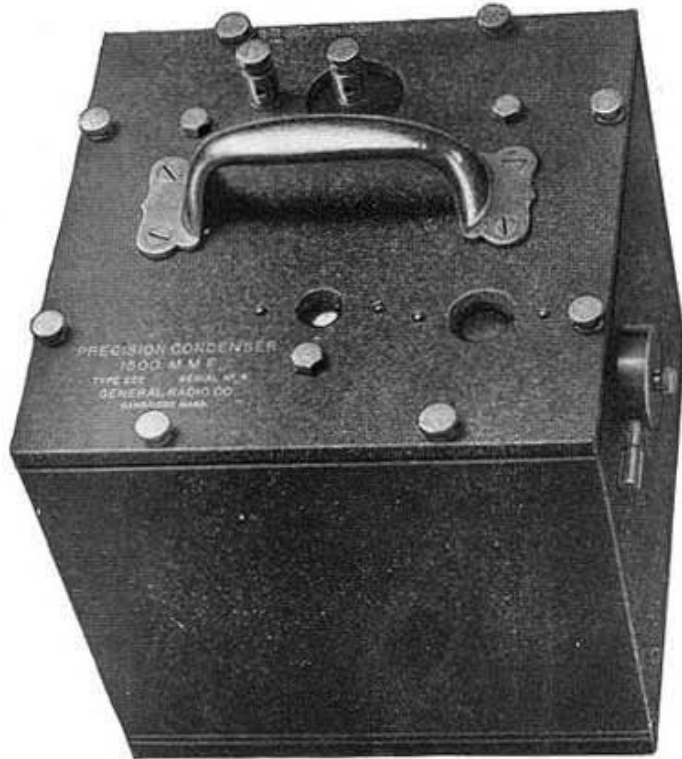

The plates are of heavy aluminum, widely separated by accurately turned spacers, and firmly clamped between substantial cast metal end plates. A steel shaft, carrying the rotating plates, turns in cone-shaped bronze bearings. The adjustment is locked after the condenser has been subjected to a rotation test to insure the proper fitting of the bearings.

The rotary plates are turned by a worm and gear, thus permitting fine control. The worm is held by spring tension in position against the gear to prevent backlash. This is the same method used in accurate dividing engines. The worm is lapped in to insure perfect fit, and the condenser then tested for backlash in the laboratory.

ELECTRICAL. The stator plate assembly is insulated from the rigid end plates, carrying the rotor assembly, by isolantite blocks. As these blocks are small in volume, and placed in a weak, non-varying electrostatic field, the condenser has a very low power factor, 0.007% at 1000 MMF.

GENERAL RADIO COMPANY

When using this condenser in measuring the power factor of absorbing condensers the fact that the field, where the isolantite supports are located, does not vary with condenser setting is of importance, because it permits the assumption that the precision condenser is the equivalent of two condensers in parallel, one being a perfect condenser of variable capacity, the other a small fixed condenser with which is associated all the dielectric losses.

The temperature coefficient of this condenser is practically nil, and there is no change in capacity with frequency. The equivalent series resistance at 1000 cycles and 1000 MMF. is approximately 11 ohms. The breakdown potential is about 800 volts (peak). The minimum capacity is 50 MMF.

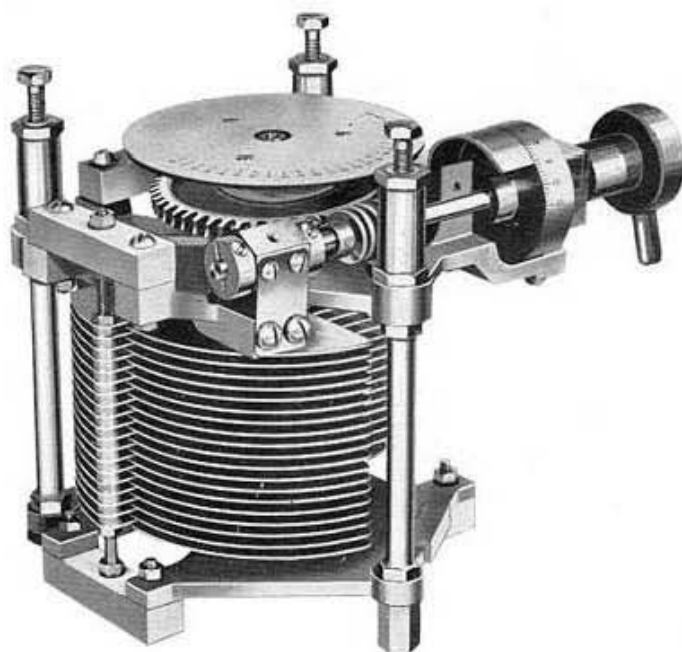

SCALES AND CALIBRATION. Attached to the main shaft is a scale, divided into 25 equal parts, while on the worm shaft is a second scale, the circumference of which is divided into 100 equal parts. Since one complete turn of the worm shaft moves the main scale through one division, the position of the rotary plates may be read directly to 1 part in 2500—equivalent to about 0.6 MMF. Since these sub-scale divisions are $\frac{1}{16}$ of an inch apart, it is easy to estimate to one-fifth of a division. Each condenser is supplied with a chart giving, with an accuracy of 1 MMF., the condenser calibration at 26 points.

MOUNTING. The condenser is mounted on a $\frac{1}{4}$ inch aluminum plate finished in permanent black crackle lacquer. This plate forms the

GENERAL RADIO COMPANY

top of the case, which is of polished walnut and lined with a copper shield. In order that the condenser may be kept free from dust the two scales are read through glass windows set into the aluminum top. A moulded bakelite rotating handle extends into the box and engages the worm shaft. The carrying handle and other metal parts are nickel plated.

A substantial whitewood carrying case, provided with lock and carrying handle, is furnished with each instrument.

Type 222 Precision Condenser 1500 MMF.....\$90.00

Dimensions $8\frac{1}{4}''$ x $8\frac{3}{4}''$ x $9''$. Weight 15 lbs.

Code Word: COPAL.

TYPE 246 CONDENSERS

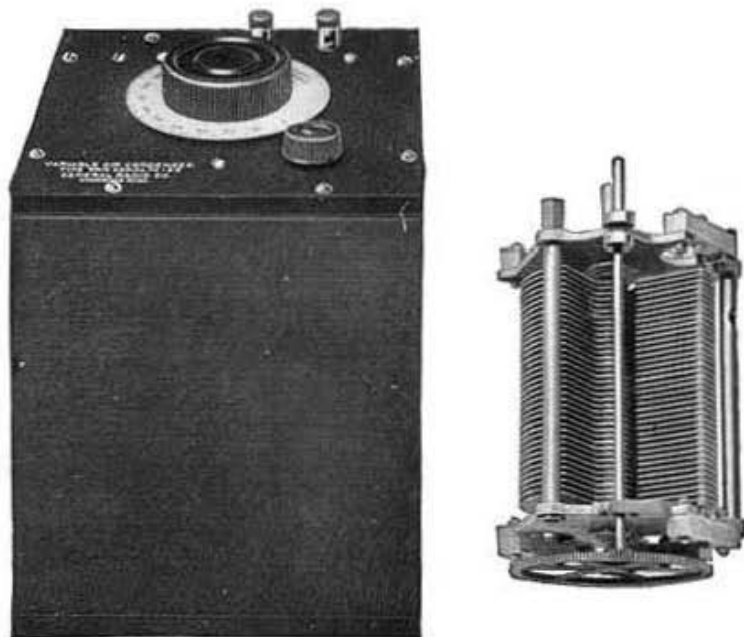

The Type 246 Variable Air Condenser is similar in construction to the Type 222 Precision Condenser. It is better adapted to use as a secondary standard than the Type 239 Variable Air Condenser and, in fact, is satisfactory for many uses where the greater precision of setting of the Type 222 Precision Condenser is not required.

There is no change in capacity with frequency. The temperature coefficient is practically zero. The dielectric is isolantite, whose dielectric properties are superior to porcelain and which is, in addition, non-absorbent. The dielectric is of small volume and placed in a weak and

GENERAL RADIO COMPANY

practically constant field. As the field through the dielectric does not vary with the position of the plates, the condenser may be assumed to be equivalent to two parallel condensers, one a fixed condenser of small capacity, with all the power loss, the other a perfect variable condenser. This fact is very important when the condenser is used in measuring dielectric losses in connection with the Type 216 Capacity Bridge.

A reduction gearing is provided for ease in making accurate capacity adjustments. As the rotor of the condenser is grounded to the frame, which effectively shields the stator, there is no difficulty due to stray capacities.

USES. The Type 246 Variable Air Condenser meets the wide demand in radio and general laboratory work for a variable condenser of considerable range, low power factor and constant capacity. It is useful as a laboratory standard of capacity in bridge measurements of condenser resistance in tuned circuits and in radio-frequency resistance measurements.

LOSSES. The power factor of the Type 246 Variable Air Condenser at 1500 MMF. is about 0.005%. The resistance at 1000 cycles is about 12 ohms, and at 300 kilocycles this resistance is approximately 0.018 ohms.

CONSTRUCTION. The illustration shows the general construction. The plates are heavy aluminum, accurately spaced. The main shaft is fitted between cone bearings, so that there is practically no end-play. These bearings are ground in before their final adjustment. In the reduction gearing, mentioned above, a small fibre pinion is pressed against the large gear by a phosphor bronze spring so that there is no backlash. Heavy cast bronze end plates separated by large brass spacing pillars make a very rigid assembly. The cabinet is copper lined.

CALIBRATION. The minimum and maximum capacity of each condenser is marked on the bottom of the case. The average capacities for each of the three sizes of this type of condenser follow:

<i>Type</i>	<i>Min. Cap.</i>	<i>Max. Cap.</i>	<i>Voltage (Peak)</i>
246-L	55 MMF.	1500 MMF.	800
246-M	70 MMF.	3000 MMF.	800
246-P	72 MMF.	5000 MMF.	550

If desired, a celluloid protected calibration curve, accurate to within 0.5%, is supplied at an extra charge of \$4.00.

FINISH. The condenser is mounted in an attractive walnut case with engraved hard rubber panel. A four-inch silvered dial, divided into one hundred divisions, is securely fastened to the main shaft.

GENERAL RADIO COMPANY

Type 246-L Condenser, 1500 MMF. capacity.....\$38.00
Dimensions $7\frac{1}{2}$ " x $7\frac{1}{2}$ " x $8\frac{1}{4}$ ". Weight $11\frac{3}{8}$ lbs.
Code Word: CEDAR.

Type 246-M Condenser, 3000 MMF. capacity.....\$45.00
Dimensions $7\frac{1}{2}$ " x $7\frac{1}{2}$ " x $11\frac{1}{2}$ ". Weight $14\frac{3}{4}$ lbs.
Code Word: CHAOS.

Type 246-P Condenser, 5000 MMF. capacity.....\$54.00
Dimensions $7\frac{1}{2}$ " x $7\frac{1}{2}$ " x $11\frac{1}{2}$ ". Weight $15\frac{3}{4}$ lbs.
Code Word: CHARY.

Mounted Calibration Curve, for any of above condensers.....\$4.00

TYPE 239 CONDENSERS

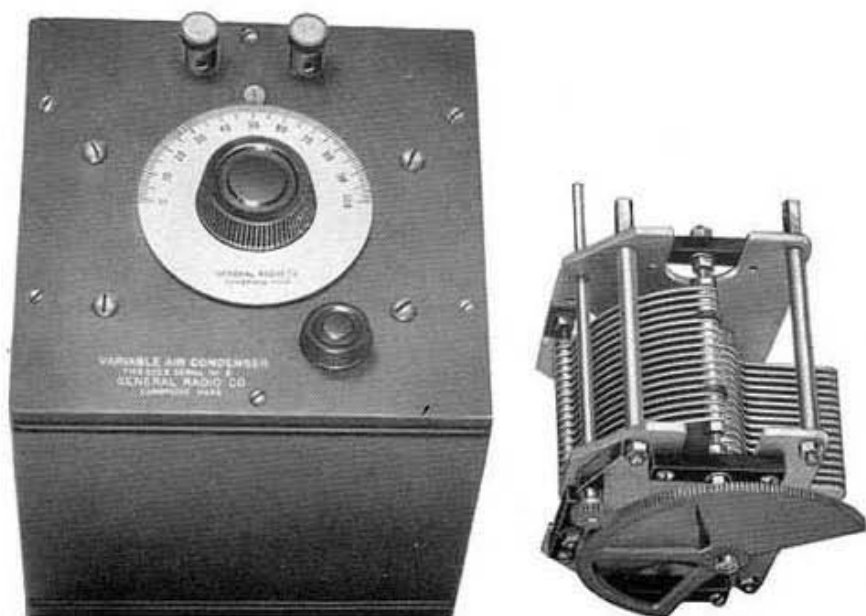

The Type 239 Condenser has end plates and condenser plates of aluminum. The rotor plates are so shaped as to give a nearly constant relation between wavelength and angular variation. The rotor bearings are in direct contact with the end plates. The stator is supported from strips of hard rubber, so placed that the field through them is weak, and practically non-varying for different capacity settings. The rotor turns in locked cone bearings and is counterweighted. A slow motion gear is supplied when desired.

GENERAL RADIO COMPANY

The Type 239 Condenser is supplied either unmounted or in a walnut case with bakelite panel.

The equivalent series resistance of the Type 239 Condenser is 12 ohms at 1000 cycles at the 1000 MMF. setting. The minimum capacity of the 1000 MMF. condensers is 20 MMF. and that of the 2000 MMF. condensers is 25 MMF. The maximum voltage that should be applied to these condensers is 500 D.C.

USES. The Type 239 Condenser may be used in tuned circuits, in wavemeters and in bridge work.

- Type 239-F 1000 MMF. Mounted. Without gear.....\$15.00
Dimensions 6" x 6" x 7". Weight 4 $\frac{1}{4}$ lbs.
Code Word: BABEL.
- Type 239-E 1000 MMF. Mounted. With gear.....\$18.00
Dimensions 6" x 6" x 7". Weight 4 $\frac{3}{8}$ lbs.
Code Word: BANDY.
- Type 239-H 1000 MMF. Unmounted. Without gear.....\$7.00
Dimensions 4 $\frac{1}{2}$ " x 4 $\frac{3}{4}$ " x 6". Weight 1 $\frac{3}{4}$ lbs.
Code Word: BARON.
- Type 239-G 1000 MMF. Unmounted. With gear.....\$10.00
Dimensions 4 $\frac{1}{2}$ " x 4 $\frac{3}{4}$ " x 6". Weight 2 lbs.
Code Word: BASAL.
- Type 239-K 2000 MMF. Mounted. Without gear.....\$18.50
Dimensions 6" x 6" x 9". Weight 5 $\frac{1}{2}$ lbs.
Code Word: BASIN.
- Type 239-J 2000 MMF. Mounted. With gear.....\$21.50
Dimensions 6" x 6" x 9". Weight 5 $\frac{1}{2}$ lbs.
Code Word: BATTY.
- Type 239-M 2000 MMF. Unmounted. Without gear.....\$10.50
Dimensions 4 $\frac{1}{2}$ " x 4 $\frac{3}{4}$ " x 8". Weight 2 $\frac{3}{4}$ lbs.
Code Word: BAYAN.
- Type 239-L 2000 MMF. Unmounted. With gear.....\$13.50
Dimensions 4 $\frac{1}{2}$ " x 4 $\frac{3}{4}$ " x 8". Weight 2 $\frac{3}{4}$ lbs.
Code Word: BEFIT.

A ten point calibration is supplied with any of the mounted types with gears at \$1.50 additional, or a mounted calibration curve, accurate to within 1%, is supplied at \$3.50 above the price listed.

GENERAL RADIO COMPANY

Condensers are also required for the tuning of temporary or permanent laboratory circuits, and for experimental receiver or transmitter construction. These condensers are of the small capacities, 500 MMF. and less. They are available in several plate shapes and a variety of capacities for various requirements.

Both metal end plate and hard rubber end plate types are available. The rotor and stator units of both types are identical. In the metal end plate types the rotors are grounded to the end plates. The plates of the rotor and of the stator sections are each soldered together in a jig which accurately spaces the plates.

The equivalent series resistance of both types is about the same, approximately 0.3 ohms at 500 MMF. and at 1000 KC. The minimum capacity of all types ranges from approximately 15 MMF. on the small capacities to 25 MMF. on the larger sizes.

TYPE 247 CONDENSERS



These are the condensers which stand out pre-eminently as the leaders of radio-frequency condensers and still sell at popular prices. The panel mounting models have straight-line wavelength plates. The case mounted models have straight-line capacity plates and dials with capacity calibrations. They make excellent standards for the experimenter.

Type	Capacity	Description	Dimensions	Weight	Code Word	Price
247-F	500 MMF.	Panel Mntg. with etwt.	4" x 4" x 4½"	1 lb.	COCOA	\$3.00
247-H	500 MMF.	Panel Mntg. with gear	4" x 4" x 4½"	1½ lb.	COMIC	3.75
247-E	500 MMF.	Case Mtd. without gear	5" x 5" x 4½"	2 lb.	COUPE	5.00
247-G	500 MMF.	Case Mtd. with gear	5" x 5" x 4½"	2¼ lb.	COLIC	5.75
247-N	350 MMF.	Panel Mntg. with etwt.	4" x 4" x 4½"	1 lb.	ABASE	2.75
247-P	350 MMF.	Panel Mntg. with gear	4" x 4" x 4½"	7/8 lb.	ABBEY	3.50
247-K	250 MMF.	Panel Mntg. with etwt.	4" x 4" x 4"	7/8 lb.	CARGO	2.50
247-M	250 MMF.	Panel Mntg. with gear	4" x 4" x 4"	7/8 lb.	CIGAR	3.25
247-J	250 MMF.	Case Mtd. without gear	5" x 5" x 4½"	1¾ lb.	CANON	4.50
247-L	250 MMF.	Case Mtd. with gear	5" x 5" x 4½"	2 lb.	CAROM	5.25

GENERAL RADIO COMPANY

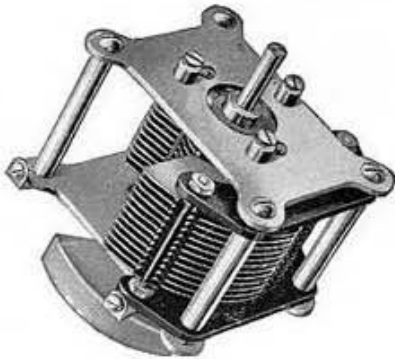

Type 334 Condenser

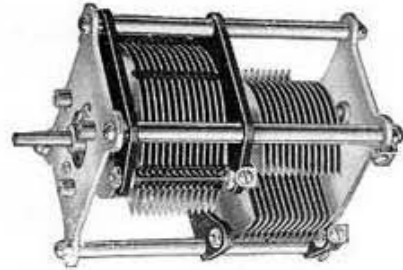

Type 374 Condenser

TYPE 334 CONDENSERS

Where the shielding effect of metal end plates is desirable the Type 334 Condensers are particularly recommended for use in receiving sets. They are of low loss construction and very rugged.

The Type 334-T and V Condensers are similar in appearance to all other Type 334 Condensers except that they have double spacing for use in short-wave transmitters on voltages up to 2000. They are supplied with counterweights only.

Type	Capacity	Description	Dimensions	Weight	Code Word	Price
334-F	500 MMF.	Panel Mntg. with cwt.	3 $\frac{3}{4}$ " x 3 $\frac{3}{4}$ " x 4 $\frac{1}{4}$ "	1 $\frac{1}{2}$ lb.	BEGIN	\$3.25
334-H	500 MMF.	Panel Mntg. with gear	3 $\frac{3}{4}$ " x 3 $\frac{3}{4}$ " x 4"	1 $\frac{1}{2}$ lb.	BELAY	4.00
334-N	350 MMF.	Panel Mntg. with cwt.	3 $\frac{3}{4}$ " x 3 $\frac{3}{4}$ " x 4"	1 $\frac{1}{2}$ lb.	BESET	3.00
334-P	350 MMF.	Panel Mntg. with gear	3 $\frac{3}{4}$ " x 3 $\frac{3}{4}$ " x 3 $\frac{3}{4}$ "	1 $\frac{1}{2}$ lb.	BEVEL	3.75
334-K	250 MMF.	Panel Mntg. with cwt.	3 $\frac{3}{4}$ " x 3 $\frac{3}{4}$ " x 3 $\frac{1}{2}$ "	1 $\frac{1}{2}$ lb.	BELOW	2.75
334-M	250 MMF.	Panel Mntg. with gear	3 $\frac{3}{4}$ " x 3 $\frac{3}{4}$ " x 3 $\frac{1}{4}$ "	1 $\frac{1}{2}$ lb.	BERYL	3.50
334-T	100 MMF.	Panel Mntg. without gear	3 $\frac{3}{4}$ " x 3 $\frac{3}{4}$ " x 4"	1 $\frac{1}{4}$ lb.	BILLY	2.75
334-V	50 MMF.	Panel Mntg. without gear	3 $\frac{3}{4}$ " x 3 $\frac{3}{4}$ " x 3 $\frac{3}{4}$ "	1 $\frac{1}{4}$ lb.	BIPED	2.50

TYPE 374 CONDENSERS

These condensers are similar in general construction to the Type 334 Condensers except that the plates are cut so as to give a straight-line frequency variation. A feature of this type of straight-line frequency condenser is that it requires no more panel space than the straight-line wavelength type of condenser and may be substituted for either the Type 247 or 334 Condensers since the mountings are exactly the same.

Type	Capacity	Description	Dimensions	Weight	Code Word	Price
374-B	125 MMF.	Single without gear	3 $\frac{3}{4}$ " x 3 $\frac{3}{4}$ " x 3 $\frac{1}{2}$ "	1 lb.	BONUS	\$2.75
374-K	250 MMF.	Single without gear	3 $\frac{3}{4}$ " x 3 $\frac{3}{4}$ " x 4 $\frac{1}{4}$ "	1 $\frac{1}{8}$ lb.	BOSOM	3.50
374-N	350 MMF.	Balanced without gear	3 $\frac{3}{4}$ " x 3 $\frac{3}{4}$ " x 5"	2 lbs.	BOXER	4.25
374-F	500 MMF.	Balanced without gear	3 $\frac{3}{4}$ " x 3 $\frac{3}{4}$ " x 6"	2 $\frac{1}{8}$ lbs.	BRAVO	5.00

GENERAL RADIO COMPANY

TYPE 557 AMATEUR-BAND CONDENSER

In designing short-wave receivers, it is desirable to cover only a comparatively narrow range of frequency on one coil, thus giving proper separation between stations. The condenser used in the Type 558 Amateur-Band Frequency Meter is particularly adapted for this service.

This condenser consists of six stator plates, two rotor plates of the straight-line wavelength type, and two additional rotor plates, which are complete circular discs. These latter plates revolve with the shaft, but produce no change in capacitance, hence they act as a fixed condenser shunting a variable condenser. The minimum capacitance is approximately 43 MMF., and the maximum, 70 MMF. This condenser is supplied for panel mounting only, without gear.

Type 557 Amateur-Band Condenser.....\$3.25

Dimensions $3\frac{5}{8}''$ x $3\frac{3}{4}''$ x $3\frac{3}{4}''$. Weight 12 oz.

Code Word: BEGOT.

TYPE 368 MICRO-CONDENSERS

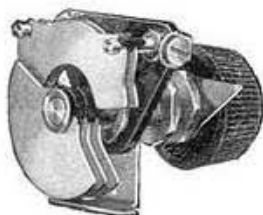

A small balancing or vernier condenser is required in some of the most recent circuits. For such use the Type 368 Single Hole Mounting Micro-Condensers are particularly recommended.

Type	Capacity	Description	Dimensions	Weight	Code Word	Price
368-A	15 MMF.	Micro-Condenser	$2''$ x $2''$ x $1\frac{7}{8}''$	2 oz.	BULLY	\$.75
368-B	50 MMF.	Micro-Condenser	$2''$ x $2''$ x $2''$	$2\frac{1}{2}$ oz.	BURIN	1.00

— OO —

All soldered plate condensers listed in this catalog or used in any of the apparatus listed are manufactured under United States Patent No. 1,542,995. All condensers other than those having semi-circular plates are manufactured also under United States Patent No. 1,258,423.

RESISTANCE DEVICES

STANDARD RESISTANCE UNITS

Resistance standards which are to be used for alternating current measurements must maintain their resistance at the stated values in spite of changes of frequency and temperature, and over long periods of time. The General Radio Company has developed a type of resistance which is extremely satisfactory for this use.

Long experience has shown that the alloy known as manganin does not change in resistance with age. It is essential that the form on which the resistance is wound does not change so as to introduce stresses in the wire. Care in soldering insures freedom from corrosion. After being wound, the resistance cards are aged for about six months before being adjusted to their final values. This ageing process is to permit the metal to reach a state of rest following the stress incident to winding with the wire necessarily under tension. The observance of these precautions insures a coil whose resistance is unchanging with time.

The temperature coefficient of the manganin wire used is so small that the resistance may be considered constant with changes in temperature in ordinary engineering work. As the coefficient is constant over a considerable range it is a simple matter to calculate the correction for more precise work.

In order to meet the third requirement, independence from frequency changes, a special form of winding must be resorted to in order to eliminate inductance and capacitance effects. In the General Radio coils the Ayrton-Perry method, illustrated in the diagram, is employed. A thin bakelite form is used. A single wire is first wound on with a space left between turns equal to the diameter of the wire. A second wire, connected so as to be in parallel with the first, is then wound on the form in the spaces between the turns of the first wire. The direction of rotation of the second winding is opposite that of the first, so that the currents in the two portions of the winding flow in opposite directions. This arrangement also keeps adjacent wires at nearly equal potential, unlike the usual type of bifilar winding which makes the ends of the winding adjacent. Thus both inductance and capacitance effects are kept at a minimum.

Resistance cards of this character are available in the form of a number of resistance devices described in the following pages. These units are also used in General Radio bridges.

GENERAL RADIO COMPANY

For coils in excess of 1000 ohms, resistance tape is used. This is tape in which the wool is the resistance wire, and the warp cotton threads which hold the tape together. This type of winding is, of course, non-inductive and very compact where a high current-carrying capacity is not essential.

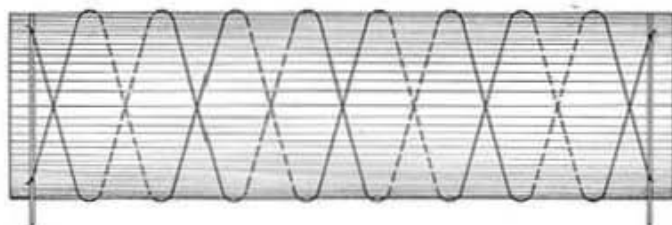

The current-carrying capacity of the one-tenth ohm units is one ampere, that of the one ohm units 250 milliamperes, that of the ten ohm units 100 milliamperes, and that of the one hundred and one thousand ohm units 50 milliamperes. The coils above 1000 ohms will carry about 1 watt.

TYPE 102 DECADE RESISTANCES

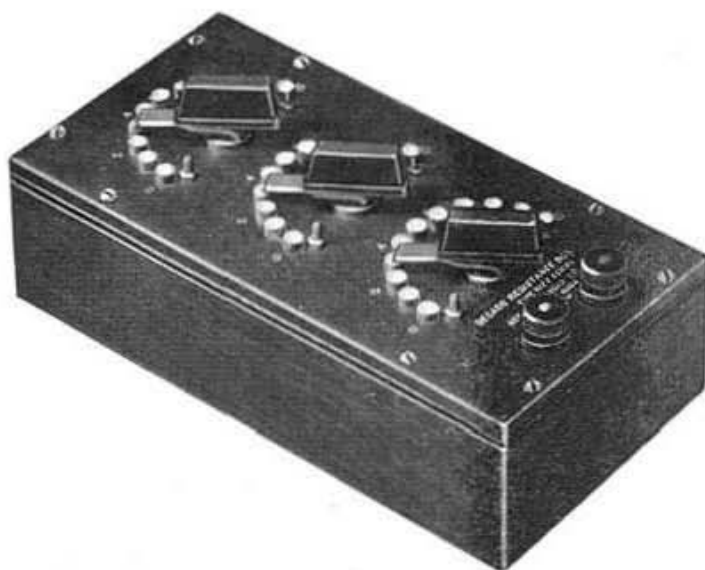

For general laboratory use the most convenient resistance arrangement is that of decade units. By such a method it is possible to get nearly any value of resistance desired. Such units are compact and rugged. With the use of multiple-leaf contact brushes with each leaf making independent contact, and with the ends of these brushes so cut that they

GENERAL RADIO COMPANY

are not tangent to the path of travel, thereby preventing the cutting of grooves in the contact studs, the dial method of mounting decade resistance units is fast replacing the plug method of connection. This method eliminates the inconvenience of the shifting of plugs, and also their high contact resistance.

Attention is called to the fact that each decade dial has eleven contact studs, a zero and ten steps. This feature is especially convenient when working at the upper or lower ends of a dial.

These decade boxes are made in three general types, two, three and four dials. These general types, however, may cover different ranges.

The accuracy on direct current of the 0.1 ohm units, including switch contact resistance, is 1%, that of the 1 ohm units 0.25%, and that of the larger units 0.1%. The wire used has a practically nil temperature coefficient of resistance and contains no iron.

When used as voltage drop devices the units in the 1 ohm and 10 ohm dials are accurate to 0.25% at 10 kilocycles and 2% at 20 kilocycles. The 100 and the 1000 ohm units are accurate to 2% at 10 kilocycles. These values apply between the terminals of the box with any or all the steps of the dial in circuit.

The Type 102 Decade Resistance Boxes are suitable for use in series-tuned circuits for resistance measurements at much higher frequencies. When so used, the accuracy of the 1 ohm units is to within 1% up to 1500 kilocycles and to within 5% at 3000 kilocycles, that of the 10 ohm units to within 1% up to 1500 kilocycles, to within 5% at 2000 kilocycles and to within 10% at 3000 kilocycles. In order to attain this accuracy, the circuit must be accurately tuned.

All boxes are enclosed in walnut cabinets with bakelite panel. All exposed metal parts are nickel plated.

<i>Type</i>	<i>Units</i>	<i>Code Word</i>	<i>Price</i>
102-D	10 one-tenth ohm coils	DECOY	\$22.00
	10 one ohm coils		
102-E	10 one ohm coils	DECYR	\$24.00
	10 ten ohm coils		
102-H	10 ten ohm coils	DIVAN	\$25.00
	10 one hundred ohm coils		
102-F	10 one-tenth ohm coils	DELTA	\$30.00
	10 one ohm coils		
	10 ten ohm coils		
102-G	10 one ohm coils	DIGIT	\$32.00
	10 ten ohm coils		
	10 one hundred ohm coils		

GENERAL RADIO COMPANY

<i>Type</i>	<i>Units</i>	<i>Code Word</i>	<i>Price</i>
102-K	10 one-tenth ohm coils	DEFER	\$42.00
	10 one ohm coils		
	10 ten ohm coils		
	10 one hundred ohm coils		
102-J	10 one ohm coils	DEBIT	\$50.00
	10 ten ohm coils		
	10 one hundred ohm coils		
	10 one thousand ohm coils		
102-L	10 ten ohm coils	DECAY	\$85.00
	10 one hundred ohm coils		
	10 one thousand ohm coils		
	10 ten thousand ohm coils		

<i>Number of Dials</i>	<i>Dimensions</i>	<i>Weight</i>
2	7 ³ / ₈ " x 5" x 5"	2 ¹ / ₂ lbs.
3	10" x 5" x 5"	4 lbs.
4	12 ⁵ / ₈ " x 5 ¹ / ₄ " x 5 ¹ / ₂ "	6 lbs.

TYPE 133 RESISTANCE STANDARDS



Resistance Standards, wound by the method previously described, are available in the sizes listed. The accuracy of adjustment is to within 0.1% for all values. The cases are of moulded bakelite.

GENERAL RADIO COMPANY

Type	Resistance	Current	Code Word	Price
133-A	1 Ohm	250MA.	RECUR	\$6.00
133-B	5 Ohms	100MA.	REFER	6.00
133-C	10 Ohms	100MA.	REGAL	6.00
133-D	50 Ohms	50MA.	RELAX	6.00
133-E	100 Ohms	50MA.	RELIC	6.00
133-F	500 Ohms	50MA.	REPAY	6.00
133-G	1000 Ohms	50MA.	REPEL	7.00
133-H	10,000 Ohms	15MA.	PETAL	10.00
133-K	25,000 Ohms	15MA.	PASHA	20.00

The Type 133-K Tapped Resistance listed above will be found particularly useful in amplification measurements, as it covers the range of usual tube impedances. The total resistance is 25,000 ohms, and is tapped in 5,000 ohm steps.

The following resistances may be obtained by suitable series and parallel connections:

1000	2500	5833	8750	15000
1250	3333	6750	10000	17500
1444	3750	6667	11667	20000
1667	4000	7000	12500	25000
2000	4167	7500	13333	
2143	5000	8333	13750	

Dimensions $3\frac{3}{4}$ " x $2\frac{1}{2}$ ". Weight 4 oz.

TYPE 249 AND TYPE 329 ATTENUATION NETWORKS

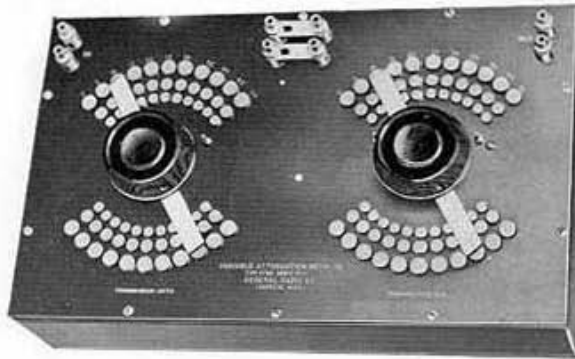

Type 329 Attenuation Network

In the laboratory devoted to communication engineering the need is often felt for an instrument whereby a given signal may be weakened, or attenuated, by a definite known amount. For instance, it may be

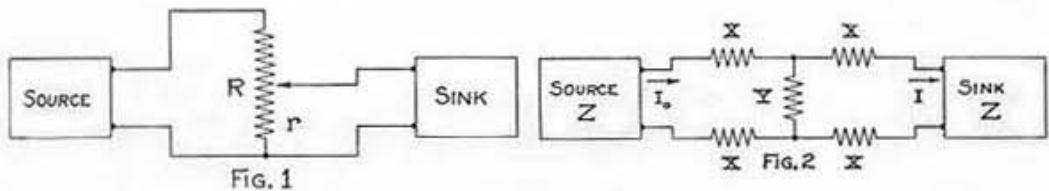

GENERAL RADIO COMPANY

convenient to measure one signal in terms of another by decreasing the louder until both are of the same intensity, a procedure frequently used in measuring the gain in amplifiers or the attenuation in line circuits.

One method of doing this is illustrated in Figure 1, which shows the familiar form of potentiometer. A fixed resistance R is connected across the terminals of the source, while a variable portion r of this resistance is connected across the sink into which the attenuated signal is fed. If this sink is a voltage-operated device, drawing no current, the potential at its input terminals will be equal to the output voltage of the source multiplied by the simple ratio r/R . The impedance of the potentiometer, viewed from the source, will, of course, be equal to R , and should be made equal to the characteristic impedance of the source, viewed from its output terminals, if optimum working conditions are to

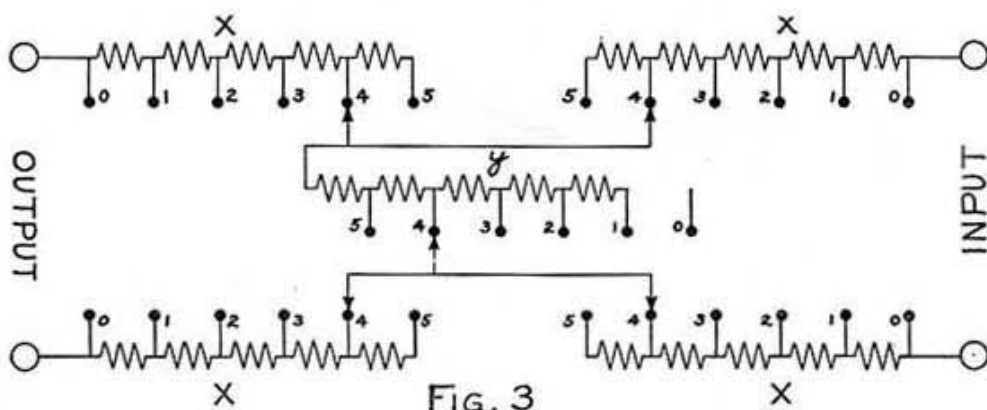

be attained. Under these conditions the attenuation of the potentiometer may readily be calibrated in terms of TU (transmission units). If, however, the sink is a current-consuming device, then the expression for the attenuation of the potentiometer becomes more complicated, involving the characteristic impedance of the sink. Furthermore, the impedance of the potentiometer, viewed from either end, is a variable, changing with each setting of the adjustable contact. This will give rise to electrical reflections which will tend to produce wave distortion and kindred troubles.

If, however, we wish to produce a distortionless and easily computable attenuation between a source and sink, each having the same characteristic impedance Z , we may make use of the attenuation network shown in Figure 2. This so-called H-type network comprises four equal series resistances X , and additional shunt resistance element Y , connected

GENERAL RADIO COMPANY

between the source and sink in the symmetrical manner indicated. If such a network is intended to introduce a definite number N of transmission units of attenuation, then, the values of X and Y may be computed from the equations:

$$X = \frac{Z}{2} \left(\frac{k-1}{k+1} \right)$$

$$Y = 2Z \left(\frac{k}{k^2-1} \right)$$

$$\text{where } k = \frac{I_0}{I} > 1$$

the ratio of the current, I_0 , leaving the source to the current, I , entering the sink.

Expressed in terms of transmission units:

$$k = 10^{N/20} = \text{antilog } \frac{N}{20}$$

where N equals the attenuation in transmission units.

A single such network offers, of course, a definite amount of attenuation determined by the values of X and Y . If, however, all five branches of the network are made adjustable by steps, as indicated schematically in Figure 3, and if the five switch arms are moved in unison to the corresponding switch points, then, by a proper calibration of the X and Y branches, the characteristic impedance Z of the network may be maintained constant while its attenuation is varied by any desired steps.

In certain lines of work it may be desirable to ground the center point of the Y shunt branch. This can be accomplished by using a network with six adjustable switch arms, wherein the shunt resistance Y is bisected into two equal parts.

The General Radio Company has developed a series of attenuation networks operating on these principles. Each instrument contains two decade H-type networks which may be used individually or joined in series. In one series of these instruments the decades are calibrated in steps of 5 TU and 0.5 TU respectively, giving a total attenuation of 55 TU; while in the second series, the decades are calibrated in steps of 2 TU and 0.2 TU, giving a total attenuation of 22 TU. These instruments may be obtained calibrated for a characteristic impedance of 600 ohms or 6000 ohms, as desired. The attenuation is controlled by a single dial switch for each decade.

GENERAL RADIO COMPANY

Instead of varying attenuation of the five branches of a single network section, as previously described, the same results may be obtained by adding two or more fixed sections in series. A four-pole double-throw switch serves to insert or remove each particular section at will. Given the characteristic impedance and the desired attenuation in transmission units of such a section, the necessary values of the X and Y branches may be computed directly from the previous equations.

In place of the symmetrical H-type network, it is frequently permissible to utilize the simpler but unbalanced T-type networks for attenuation purposes. Here a double-pole double-throw switch suffices to throw each section in or out of the circuit. The resistance values are calculated in the same manner, except that each of the two X branches has, obviously, the value 2X in order to maintain the same total series resistance in the network.

For certain types of experimental work an adjustable attenuation box having one TU as the smallest unit is sufficient. Accordingly the General Radio Company has developed a series of Type 249 Attenuation Boxes containing six or eight fixed sections which are controlled by individual switches. While this type does not permit as rapid manipulation as the Type 329 Networks, it is, nevertheless, quite satisfactory. The illustration shows the appearance of one of these boxes.

The eight section boxes are calibrated in steps of 1-2-3-4-10-20-30-40 TU, affording thereby a total attenuation, by one TU steps, up to 110 TU. The six section boxes are calibrated in steps of 1-2-4-8-16-32 TU, totalling 63 TU.

The following types are built to order:

Type	Characteristic Impedance	Total Attenuation	Code Word	Price
329-H	600	55 TU	TENUTORROD	\$220.00
329-J*	600	55 TU	TENUTORPIG	\$240.00
329-K	6000	55 TU	TENUTORTOP	\$235.00
329-L*	6000	55 TU	TENUTOREYE	\$255.00
329-M	600	22 TU	TENUTORANT	\$230.00
329-N*	600	22 TU	TENUTORBOY	\$250.00
329-O	6000	22 TU	TENUTORCAT	\$240.00
329-P*	6000	22 TU	TENUTORDOG	\$260.00

Dimensions $16\frac{7}{8}$ " x $10\frac{3}{4}$ " x 6".

The types marked * are provided with a center tap for the Y branch. A limited number of certain of these types are carried in stock; others may be built to order.

GENERAL RADIO COMPANY

Type No.	No. of Sections	Type of Section	Characteristic Impedance	Code Word	Price
249-A	6	H	600	NETWORKANT	\$100.00
249-B	6	H	6000	NETWORKBOY	\$120.00
249-C	6	T	600	NETWORKCAT	\$90.00
249-D	6	T	6000	NETWORKDOG	\$110.00
249-H	8	H	600	NETWORKROD	\$120.00
249-J	8	H	6000	NETWORKPIG	\$150.00
249-T	8	T	600	NETWORKTOP	\$100.00
249-U	8	T	6000	NETWORKEYE	\$140.00

Dimensions 6-Section Type 12¼" x 5¼" x 5¼".

Dimensions 8-Section Type 16" x 5¼" x 5¼".

NO. OF T. U.	POWER RATIO		NO. OF T. U.	POWER RATIO		NO. OF T. U.	POWER RATIO	
	GAIN	LOSS		GAIN	LOSS		GAIN	LOSS
0.1	1.023	.977	3.6	2.29	.437	7.1	5.13	.195
0.2	1.047	.955	3.7	2.34	.427	7.2	5.25	.191
0.3	1.072	.933	3.8	2.40	.417	7.3	5.37	.186
0.4	1.096	.912	3.9	2.45	.407	7.4	5.50	.182
0.5	1.122	.891	4.0	2.51	.398	7.5	5.62	.178
0.6	1.148	.871	4.1	2.57	.389	7.6	5.75	.174
0.7	1.175	.851	4.2	2.63	.380	7.7	5.89	.170
0.8	1.202	.832	4.3	2.69	.372	7.8	6.03	.166
0.9	1.230	.813	4.4	2.75	.363	7.9	6.17	.162
1.0	1.259	.794	4.5	2.82	.355	8.0	6.31	.158
1.1	1.288	.776	4.6	2.88	.347	8.1	6.45	.155
1.2	1.318	.759	4.7	2.95	.339	8.2	6.61	.151
1.3	1.349	.741	4.8	3.02	.331	8.3	6.76	.148
1.4	1.380	.724	4.9	3.09	.324	8.4	6.92	.144
1.5	1.413	.708	5.0	3.16	.316	8.5	7.08	.141
1.6	1.445	.692	5.1	3.24	.309	8.6	7.24	.138
1.7	1.479	.676	5.2	3.31	.302	8.7	7.41	.135
1.8	1.514	.661	5.3	3.39	.295	8.8	7.59	.132
1.9	1.549	.645	5.4	3.47	.288	8.9	7.76	.129
2.0	1.585	.631	5.5	3.55	.282	9.0	7.94	.126
2.1	1.622	.617	5.6	3.63	.275	9.1	8.13	.123
2.2	1.660	.603	5.7	3.72	.269	9.2	8.32	.120
2.3	1.698	.589	5.8	3.80	.263	9.3	8.51	.118
2.4	1.738	.575	5.9	3.89	.257	9.4	8.71	.115
2.5	1.778	.562	6.0	3.98	.251	9.5	8.91	.112
2.6	1.820	.550	6.1	4.07	.245	9.6	9.12	.110
2.7	1.862	.537	6.2	4.17	.240	9.7	9.33	.107
2.8	1.906	.525	6.3	4.27	.234	9.8	9.55	.105
2.9	1.950	.513	6.4	4.37	.229	9.9	9.77	.102
3.0	1.995	.501	6.5	4.47	.224	10.0	10.00	.100
3.1	2.04	.490	6.6	4.57	.219	20.0	100	.01
3.2	2.09	.479	6.7	4.68	.214	30.0	1,000	.001
3.3	2.14	.468	6.8	4.79	.209	40.0	10,000	.0001
3.4	2.19	.457	6.9	4.90	.204	50.0	100,000	.00001
3.5	2.24	.447	7.0	5.01	.200	60.0	1,000,000	.000001

GENERAL RADIO COMPANY

The table on Page 25 gives the power ratios, gain or loss, corresponding to the number N of transmission units (TU) of gain or attenuation. The numerical value of N is equal to ten times the common logarithm of the power ratio; thus,

$$N = 10 \log \frac{P_1}{P_2}$$

Expressed in terms of the transmission unit, gains or losses in successive stages are, therefore, additive.

When operating between a source and a sink of the same impedance, the power ratio is equal to the square of the voltage or current ratio, giving

$$N = 20 \log \frac{E_1}{E_2} = 20 \log \frac{I_1}{I_2}$$

Under this condition of equal impedances, the table on Page 25 may be used to obtain the voltage or current ratios by multiplying the values of TU given in the table by the factor 2.

TYPE 164 AUDIBILITY METER

In the course of measurement work it is sometimes desirable to reduce the current in a load without greatly changing the characteristic impedance of the load viewed from the source. A properly designed at-

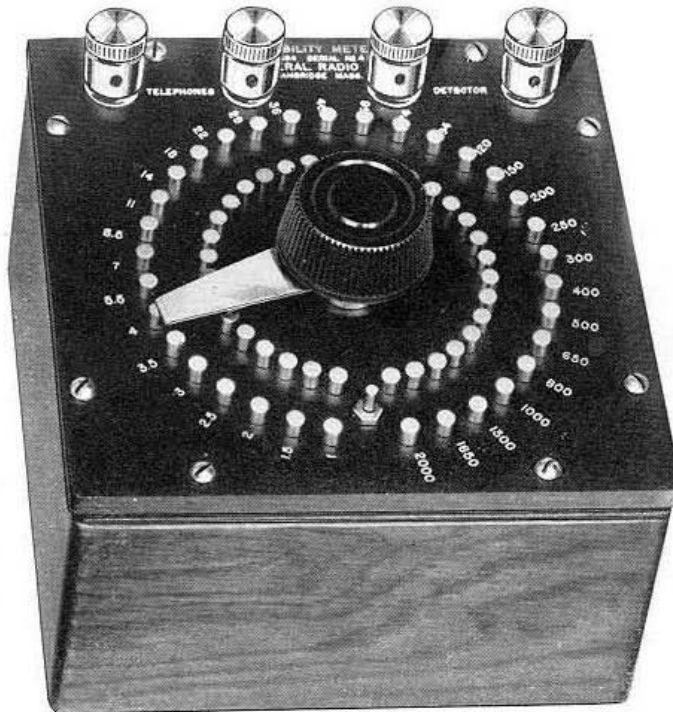

tenuation network will present a constant impedance to the source while reducing the load current to any desired degree. For some purposes,

GENERAL RADIO COMPANY

however, such as comparing the intensities of two signals by means of a listening test with telephones, a complex form of network is not required. For such approximate work at a single frequency it is entirely satisfactory to add series resistance as the load is shunted.

The Type 164 Audibility Meter was designed for use with telephones for signal comparisons. It consists of a resistance system and switches so arranged as to add series resistance as the resistance across the telephone terminals is reduced, presenting an approximately constant impedance across the input terminals. The elementary connections are shown in the diagram. R is the resistance used to shunt the telephone and R_2 is the compensating resistance; as R decreases R_2 increases.

The scale is marked with an arbitrary scale of "audibility" depending on the relation:—

$$K \text{ (audibility constant on scale)} = \frac{S + T}{S}$$

where S is the resistance of the shunt section and T the impedance of the telephones. The scale was computed on the basis of a telephone impedance of 8000 ohms.

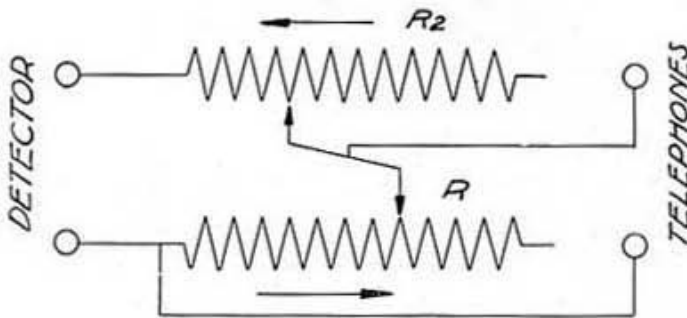

The instrument is enclosed in a walnut case with bakelite panel. Metal parts are nickel plated. The switch arm is of laminated phosphor bronze.

Type 164 Audibility Meter.....Price \$34.00

Dimensions 8" x 8" x 4". Weight 2 $\frac{3}{8}$ lbs.

Code Word: AWAKE.

TYPE 229 GALVANOMETER SHUNT

A galvanometer shunt has two general uses, as a means of protecting the galvanometer from injury while adjustments are being made, and to extend its range. For the latter use the so-called "Universal" type of shunt is most convenient. This type of shunt may be calibrated directly in ratios, as the relative multiplying power is the same for all galvanometers, regardless of the galvanometer resistance. This feature is best understood by reference to the diagram. The tapped resistance

GENERAL RADIO COMPANY



R is connected directly across the galvanometer. The bridge connects to one side of the galvanometer and to the tap switch. Solution of the circuit gives the following equation:

$$I_B = I_G \frac{R_G + R}{R} N$$

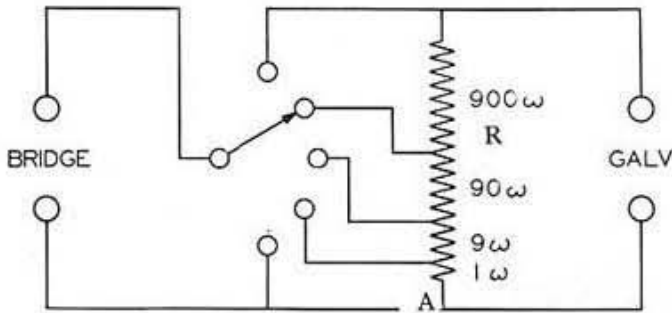

N is the ratio of the total resistance, R, to the resistance between the tap and A. This is, of course, independent of the galvanometer resistance, and the shunt may be calibrated in terms of this ratio. It is the constancy of this “relative” multiplying power that gives the name “Universal” to this type of shunt. The multiplying power of the shunt with the tap switch on unity is $\frac{R_G + R}{R}$. It is therefore important that R should be large compared to R_G for maximum sensitivity.

When used in connection with the ballistic galvanometer method of comparing capacitance, the constant resistance across the galvanometer terminals is a distinct advantage, since it insures constant damping for all shunt settings.

The General Radio Type 229 Universal Galvanometer Shunt is of

GENERAL RADIO COMPANY

the Ayrton-Mather Universal type described above. The total resistance is 1000 ohms. Taps are provided for ratios of 0.001—0.01—0.1—1.0. A short-circuit point is also provided to give complete protection to the galvanometer when so desired. The control is by means of a dial switch.

The shunt is mounted in a polished walnut box with engraved bakelite panel. Separate pairs of binding posts are provided for the bridge and galvanometer connections.

Type 229 Universal Galvanometer Shunt.....\$15.00

Dimensions 5" x 3 $\frac{1}{2}$ " x 3 $\frac{1}{2}$ ". Weight 1 lb.

Code Word: GAVOT.

TYPE 340 RHEOSTAT

In using instruments of low impedance, such as the oscillograph across a high voltage source, a rheostat of high current-carrying capacity and high resistance is required. When the source is of alternating potential, a step-down transformer would normally be used, but it is some times desirable to be certain that there is no possible source of wave-form distortion in the circuit.

The Type 340 Rheostat has a total resistance of 100,000 ohms tapped at 30—100—300—1000—3000—10,000—30,000. The upper resistances are of the "lavite" type while those below the 3000 ohms step are of our non-reactive types. The current-carrying capacity of the steps above 3,000 ohms is 10 milliamperes; that of the 1,000 to 3,000-ohm steps, 20 milliamperes; and that of the lower resistance portion, 50 milliamperes.

The resistance units are mounted in a walnut cabinet. All exposed metal parts are nickel-plated.

Type 340 Rheostat.....\$20.00

Dimensions 4 $\frac{3}{4}$ " x 3 $\frac{1}{2}$ " x 3 $\frac{1}{2}$ ". Weight 1 lb.

Code Word: SURLY.

— OO —

Resistances used as loads and for the regulation of voltage and current do not require the constancy of standards. The principal requisite of this class of resistors is a large radiating surface and a low temperature coefficient. The General Radio Company manufactures a number of such units in a wide range of resistances and ratings.

GENERAL RADIO COMPANY

TYPE 125 PHANTOM ANTENNA RESISTORS



For many tests of transmitting apparatus, it is desirable to replace the antenna by a local circuit, the constants of which are more easily and accurately determined. This also prevents interference with neighboring stations. The Type 125 Phantom Antenna Resistor is provided for this purpose.

This resistor finds many other uses about the laboratory, wherever an accurate resistance of high current-carrying capacity is required.

These units are wound on asbestos-board forms, mounted vertically, an arrangement which insures a good circulation of air. The resistance material is in the form of a ribbon, and has a very low temperature coefficient of resistance and a constant resistance up to very high frequencies. The inductance is very low. The resistance is adjusted to within 0.5% of the stated values.

The resistor is made in two sizes, Type 125-A of 4 units of 4 ohms each, and Type 125-G of 2 units of 2 ohms each. The separate units of Type 125-A have a carrying capacity of 5 amperes and those of Type 125-G 15 amperes. It is possible to connect these units so as to obtain the following combinations of resistance and carrying capacity:

Type 125-A		Type 125-G	
Resistance	Carrying Capacity	Resistance	Carrying Capacity
1 Ohm	20 Amperes	1 Ohm	30 Amperes
2 Ohms	10 Amperes	2 Ohms	15 Amperes
4 Ohms	5 Amperes	4 Ohms	15 Amperes
8 Ohms	5 Amperes		
12 Ohms	5 Amperes		
16 Ohms	5 Amperes		

GENERAL RADIO COMPANY

Type 125-A Phantom Antenna Resistor.....\$18.00
 Dimensions $7\frac{3}{4}$ " x 6" x $4\frac{1}{4}$ ". Weight $3\frac{1}{4}$ lbs.
 Code Word: RAVEN.

Type 125-G Phantom Antenna Resistor.....\$32.00
 Dimensions $10\frac{3}{4}$ " x $7\frac{5}{8}$ " x $5\frac{1}{2}$ ". Weight 7 lbs.
 Code Word: REBEL.

— OO —

Wire-wound units have proved most satisfactory for voltage regulation where appreciable current must be carried.

Potentiometers and rheostats are provided in three wattage ratings: the Type 371 Rheostat rated at 25 watts; the Type 214 Rheostat at 12 watts; and the Types 301 and 410 Rheostats rated at 6 watts. All types are wound on non-absorbent strips backed with moulded bakelite forms.

TYPE 371 POTENTIOMETERS

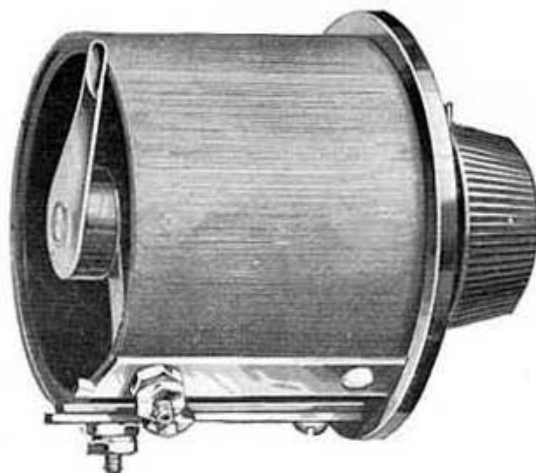

The Type 371 Potentiometers are supplied for panel mounting in the following resistances:

Resistance	Current	Code Word
5 Ohms	21 Amperes	RELAY
900 Ohms	150 Milliamperes	REDAN
2500 Ohms	90 Milliamperes	REFIT
4500 Ohms	65 Milliamperes	ROTOR
5000 Ohms	45 Milliamperes	ROWDY
18000 Ohms	35 Milliamperes	RULER

Type 371 Potentiometer.....\$5.00
 Dimensions $3\frac{1}{2}$ " x $3\frac{1}{2}$ ". Weight 7 oz.

GENERAL RADIO COMPANY

The Type 371-T Tapered Potentiometer provides a variation in the rate of change of resistance over the range of the instrument. The taper is linear. The Type 371-T Tapered Potentiometer is supplied in a 9000 ohm range only, and has a current-carrying capacity of 40 milliamperes. Type 371-T Tapered Potentiometer.....\$6.00

Code Word: SULLY.

RHEOSTATS



TYPE 214



TYPE 410



TYPE 301

TYPE 410 RHEOSTATS

The Type 410 Rheostat is of the single hole mounting type. The resistance unit is tightly wound on a specially treated non-absorbent fiber strip. Genuine moulded bakelite is used for the base. A moulded bakelite knob is also provided. The shaft is 1/4" in diameter and the outside diameter of the bushings is 3/8". The length of the bushing is such that the rheostat may be easily mounted on panels up to 3/8" in thickness.

Resistance	Current	Code Word
0.5 Ohm	3.5 Amperes	SAVOR
1.5 Ohms	2.0 Amperes	SAXON
6 Ohms	1.0 Ampere	SABOT
12 Ohms	0.75 Ampere	SALON
25 Ohms	0.5 Ampere	SALTY

The Type 410 Potentiometer is of similar construction, but is provided with a third connection.

200 Ohms	175 Milliamperes	SATIN
----------	------------------	-------

Type 410 Rheostat or Potentiometer.....\$1.00

GENERAL RADIO COMPANY

TYPE 301 RHEOSTATS

The Type 301 Rheostat and Potentiometer are similar in general appearance and construction to the Type 410 Rheostat except that they do not possess the single hole mounting feature.

The Type 301 Rheostats are designed for baseboard as well as back-of-panel mounting.

Resistance	Current	Code Word
6 Ohms	1.0 Ampere	PALSY
12 Ohms	0.75 Ampere	REMIT
25 Ohms	0.5 Ampere	RENEW

The Type 301 Potentiometer is of similar construction, but is provided with a third terminal.

200 Ohms	175 MA.	REBUS
----------	---------	-------

Type 301 Rheostat or Potentiometer.....\$1.00

Dimensions 2" x 1³/₄" x 2¹/₈". Weight 4 oz.

TYPE 214 RHEOSTATS

The Type 214 Rheostats are larger than the Type 301 Rheostats and are capable of a more accurate and gradual resistance control. These rheostats are made in two types, the Type 214-A Rheostat for back-of-panel mounting and the Type 214-B Rheostat for table mounting.

Resistance	Current	Type 214-A Panel Mounting	Type 214-B Table Mounting
0.75 Ohm	4.0 Amperes	SHINY	SILLY
2 Ohms	2.5 Amperes	RUDDY	RUMOR
7 Ohms	1.5 Amperes	RURAL	RUSTY
20 Ohms	0.75 Ampere	RAZOR	READY
50 Ohms	0.5 Ampere	RAPID	RAVEL

The Type 214 Potentiometer is of similar construction, but is provided with a third terminal.

400 Ohms	175 MA.	ROSIN	ROWEL
----------	---------	-------	-------

Type 214 Rheostats.....\$1.50

Type 214 400-ohm Potentiometer.....\$1.75

Dimensions 3" dia. x 2¹/₄". Weight 7 oz.

A rheostat of 2500 ohms is also supplied in this type for use as a variable biasing resistor in AC.-operated power amplifiers. This unit is capable of carrying 75 milliamperes.

Type 214-A 2500-ohm Rheostat.....\$2.25

Dimensions 3" dia. x 2¹/₄". Weight 7 oz.

Code Word: SYRUP.

GENERAL RADIO COMPANY

Type 214-B 2500-ohm Rheostat.....\$2.25
Dimensions 3" dia. x 2 $\frac{1}{4}$ ". Weight 7 oz.
Code Word: SYNOD.

TYPE 446 VOLTAGE DIVIDER

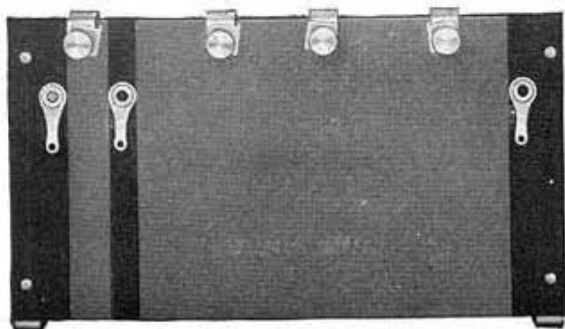

The Type 446 Voltage Divider has been especially designed for use as an output potentiometer device for 300-volt rectifying systems. It is wound in two sections, one of 15,000 ohms for the plate supply, and a 1500-ohm section for obtaining the bias voltage for a power tube. It is equipped with four adjustable sliders, suitably engraved, by means of which any combination of voltage may be obtained from the plate supply unit. This unit will dissipate 60 watts. If intended for use with a 500-volt rectifying system two voltage dividers should be connected in series.

Type 446 Voltage Divider with four sliders.....\$2.75
Dimensions 7 $\frac{1}{2}$ " x 4 $\frac{5}{16}$ " x 1 $\frac{1}{4}$ ". Weight 5 oz.
Code Word: VISTA.

CENTER TAP RESISTANCE UNITS

In using alternating current, a means of obtaining the mid-potential point of the filament is required.

The Type 439 Center Tap Resistance is designed to be mounted directly across the filament or heater terminals of any tube socket by means of adjustable contact prongs.

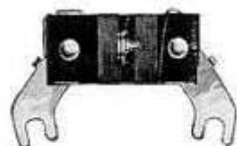

Type 439

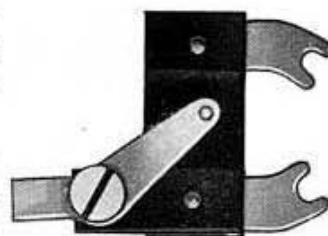

Type 437

This unit provides the center tap of the filament in circuits requiring such a connection. It has a total direct-current resistance of 60 ohms (i. e., 30 ohms on each side of the center tap) and is capable of carrying 200 milliamperes without excessive heating.

GENERAL RADIO COMPANY

Type 439 Center Tap Resistance\$.35

Dimensions $1\frac{1}{2}''$ x $1\frac{1}{4}''$ x $\frac{5}{8}''$. Weight 1 oz.

Code Word: PASTY.

Conditions often arise, due to unbalancing, when it is desirable to have a tap slightly off center across the filament of tubes having their filaments heated by alternating current. The Type 437 Adjustable Center Tap Resistance is similar to the Type 439 Center Tap Resistance except that the tap is made by means of an adjustable slider. This enables the tap to be placed at a neutral point, thus reducing hum to a minimum.

Type 437 Adjustable Center Tap Resistance\$.50

Dimensions $1\frac{3}{8}''$ x $1\frac{3}{4}''$ x $\frac{3}{8}''$. Weight 1 oz.

Code Word: PERIL.

INDUCTANCES

A wide variety of fixed and variable inductances are required in the communication laboratory. These include inductance standards, tuning and filter inductances, and chokes.

TYPE 106 STANDARDS OF INDUCTANCE

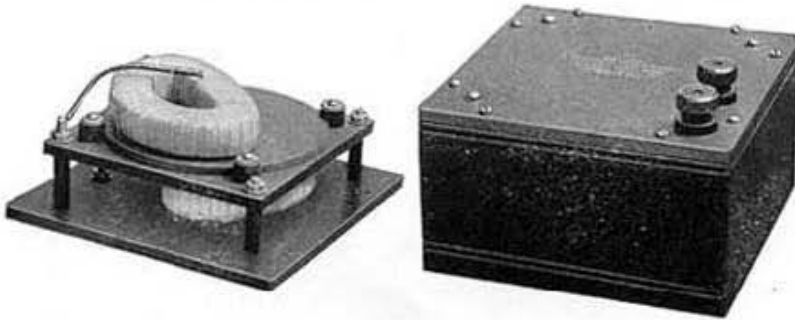

The Type 106 Inductance Standards are designed for bridge measurements at commercial and audio frequencies. The requirements of such standards include constancy of both resistance and inductance with frequency. There should be insufficient external field to cause appreciable coupling with the bridge circuits, or with neighboring inductors.

The Type 106 Inductance Standards are wound with stranded wire, having the separate strands insulated from each other, the resistance of which is substantially constant over a wide frequency range. In order to eliminate the effect of external fields so far as possible the coils are wound in two sections so connected that their external fields oppose.

The coils are form-wound and firmly bound with tape. There is no metal in the field of the coils and the small amount of metal necessarily used in the assembly of the instrument is all non-magnetic.

The adjustment of the Type 106 Inductance Standards is accurate to within 0.1%. The current-carrying capacities are as follows: 0.1 millihenry, 3.5 amperes; 1 millihenry, 1 ampere; 10 millihenrys, 500 milliamperes; 100 millihenrys, 250 milliamperes; 1 henry, 150 milliamperes.

The resistance of the standards is low and constant over a considerable frequency range. The resistance at 1000 cycles is the same as the direct-current resistance, within the accuracy of bridge measurements. The direct-current resistance of each standard is entered on the bottom of the cabinet. The standards are mounted in walnut cabinets with bakelite panels. All metal parts are nickel plated.

GENERAL RADIO COMPANY

Type	Inductance	Weight	Code Word	Price
106-L	0.10 Millihenry	2 $\frac{3}{4}$ lb.	INNER	\$25.00
106-G	1.0 Millihenry	2 $\frac{1}{2}$ lb.	INERT	25.00
106-J	10.0 Millihenrys	2 $\frac{3}{4}$ lb.	IRATE	25.00
106-K	100.0 Millihenrys	3 $\frac{1}{4}$ lb.	ISLET	25.00
106-M	1.0 Henry	5 lb.	ISSUE	36.00

Dimensions 106-L, G, J, K 5 $\frac{7}{8}$ " x 5 $\frac{7}{8}$ " x 3 $\frac{1}{2}$ ".

Dimensions 106-M 5 $\frac{7}{8}$ " x 5 $\frac{7}{8}$ " x 5 $\frac{5}{8}$ ".

TYPE 107 VARIOMETERS

Where a fixed bridge ratio is used, an adjustable standard is required. Such an arrangement is not recommended for great accuracy since it is possible to obtain a more reliable calibration on an adjustable resistor than on an adjustable inductor. It possesses superior convenience, however, for many uses. A variable inductance is also of service in the tuning of circuits.

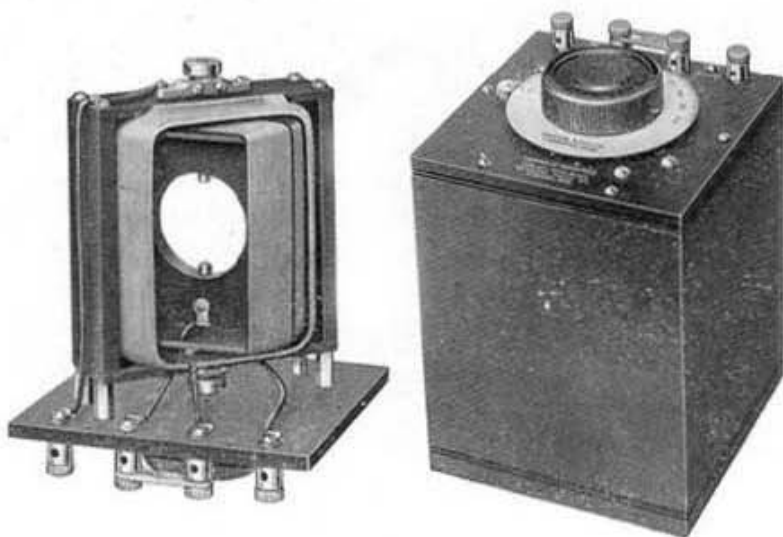

The Type 107 Variometers are designed to cover the field of usefulness for such variable inductors. They consist of two coils, both sections of cylinders, so mounted that one may be rotated within the other. Two terminals are brought out from each coil, so that the coils may be used separately, or connected in series or in parallel.

The coils are designed to have a low resistance. They are wound with stranded wire having a small variation of resistance with frequency. The field of the coils contains very little solid dielectric and practically no metal. This metal is non-magnetic, and so placed as to be in a very weak field.

GENERAL RADIO COMPANY

Attached to the bottom of each case is a certificate giving the maximum and minimum inductance when the coils are connected in series. Mounted calibration curves, accurate to within 1%, may also be supplied for an additional charge of \$5.00. The inductance is practically constant with frequency up to 50 kilocycles.

Type 107-F Variometer. About 0.04 to 0.4 millihenry. \$27.00

Carries 2 amperes continuously.

Code Word: HAPPY.

Type 107-G Variometer. About 0.4 to 4 millihenrys. \$27.00

Carries 0.75 ampere continuously.

Code Word: HARDY.

Type 107-H Variometer. About 1.4 to 18 millihenrys. \$27.00

Carries 0.50 ampere continuously.

Code Word: HAVEN.

Dimensions 6" x 6" x 8". Weight 4 $\frac{3}{4}$ lbs.

TYPE 268 VARIOCOUPLER

In experimental set-ups, variable inductors and variable couplers of small size are frequently required for the tuning of circuits.

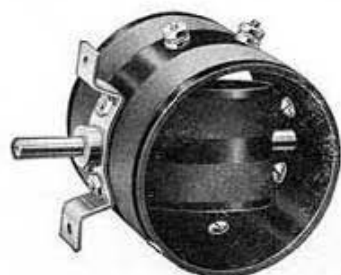

The stator inductance of the Type 268 Variocoupler is 380 microhenrys; the rotor inductance is 106 microhenrys. This instrument is especially compact and efficient in circuits which require a high-grade coupler.

Type 268 Variocoupler. \$2.50

Dimensions 4" x 4" x 2 $\frac{1}{2}$ ". Weight 6 oz.

Code Word: VALET.

TYPE 269 VARIOMETER

The Type 269 Variometer is much smaller than the average variometer, which gives it a decided advantage when compactness and portability of the set are considerations. It is efficient electrically and has a maximum-to-minimum inductance range of 820-80 microhenrys.

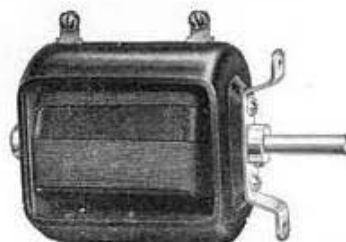

Type 269 Variometer \$3.50

Dimensions 4 $\frac{3}{4}$ " x 3" x 1 $\frac{3}{4}$ ". Weight 7 oz.

Code Word: VALID.

GENERAL RADIO COMPANY

TYPE 277 INDUCTANCE AND COUPLING COILS



A series of inductances so related as to cover a series of overlapping wavelength ranges is useful in the laboratory for setting up oscillator and tuning circuits. Plug-in bases greatly increase the usefulness of such coils.

The Type 277 Inductance Coils are so shaped in ratio of diameter to length, the materials so chosen, and the construction such that they have very low losses. The forms are of moulded bakelite.

Models A, B and C have single windings and are wound in two sections so that the mid-point may be obtained or coupling turns added at the center point. Models D, D $\frac{1}{2}$,

and D $\frac{1}{4}$ are coupling coils with a small primary winding.

Mounting holes are so arranged that Type 274-P Plugs may be inserted and the coils used interchangeably in the Type 274 Mounting Bases.

Type	Wavelength with 500 MMF. Condenser	Inductance	Code Word	Price
277-A	50 to 150 Meters	14 Microhenrys	VALOR	\$1.00
277-B	100 to 300 Meters	55 Microhenrys	VAPID	1.00
277-C	200 to 600 Meters	217 Microhenrys	VENUS	1.00
277-D	Coupling Coil, 200 to 600 Meters	217 Microhenrys	VIGIL	1.15
277-D $\frac{1}{2}$	Coupling Coil, 100 to 300 Meters	55 Microhenrys	VIPER	1.15
277-D $\frac{1}{4}$	Coupling Coil, 50 to 150 Meters	15 Microhenrys	VILLA	1.15
277-U	Unwound Coil Form		VIGOR	.70

Dimensions 5 $\frac{1}{4}$ " x 3 $\frac{1}{4}$ " x 2 $\frac{1}{4}$ ".

TYPE 379 RADIO-FREQUENCY CHOKES

Radio-frequency chokes are used to offer a high impedance to radio-frequency currents in circuits operating at audio frequencies or on direct current.

The Type 379 Chokes are designed to offer a high-radio-frequency impedance in the amateur and broadcast bands. The effective capacity does not exceed 4 MMF. at any wavelength between 20 and 640 meters. The case is of moulded bakelite. The electrical characteristics of the chokes are given in the following table.



GENERAL RADIO COMPANY

Type	Inductance	Current Rating	DC. Resistance
379-T	8 Millihenrys	200 Milliamperes	34 Ohms
379-R	60 Millihenrys	90 Milliamperes	140 Ohms

Type 379-R Radio-Frequency Choke.....\$1.25

Code Word: JEWEL.

Type 379-T Radio-Frequency Choke.....\$1.25

Code Word: JIMMY.

Dimensions, both types, 2" x 1 $\frac{3}{4}$ " x 1 $\frac{3}{4}$ ". Weight 6 oz.

TYPE 366 FILTER CHOKE

Low-frequency filters, particularly those of the "brute force type" used in plate supply units, require a filter inductor of large inductance and current-carrying capacity.

The Type 366 Filter Choke is such a unit. It consists of two 20-henry chokes, each brought out to separate connections. The DC. resistance is 350 ohms per choke.

Type 366 Filter Choke.....\$5.00

Dimensions 4 $\frac{1}{4}$ " x 3 $\frac{5}{8}$ " x 4 $\frac{1}{2}$ ".

Weight 4 $\frac{3}{4}$ lbs.

Code Word: TEPID.



TYPE 369 IMPEDANCE

The Type 369 Impedance is suitable for use in impedance-coupled amplifiers, in parallel plate-feed systems, and where an iron-cored inductance is used to prevent low-frequency interaction between circuits.

The inductance without a DC. component is 98 henrys; the DC. resistance is 1750 ohms; and the permissible current is 10 milliamperes.

Type 369 Impedance \$2.50

Dimensions 3 $\frac{1}{2}$ " x 3 $\frac{1}{4}$ " x 2 $\frac{1}{2}$ ". Weight 1 $\frac{1}{2}$ lbs.

Code Word: TONIC.

BRIDGES

GENERAL INFORMATION

The simplicity and accuracy of bridge methods of measurement have led to their general adoption for the determination of resistance, inductance, and capacitance. While there are a number of standard bridge circuits, differing in detail, all depend on balancing the voltage drops through the several arms of an impedance network so that no current flows through a null indicator connected across the network.

DIRECT-CURRENT MEASUREMENTS

The simplest form of bridge circuit, the Wheatstone, consists of four resistances (Fig. 1). When no current flows through the null indicator *D*, the voltages *a-b* and *a-d* are equal, as are *b-c* and *d-c*, i. e.:—

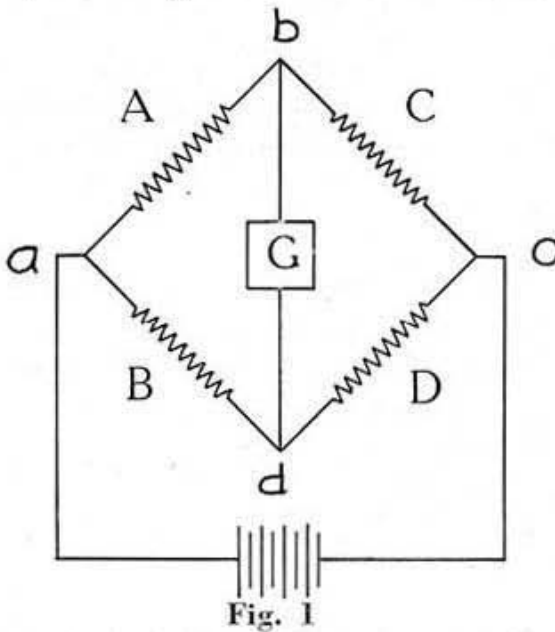

$$\begin{aligned} i_a A &= i_b B \\ \text{and } i_a C &= i_b D \\ \text{or } AD &= BC \end{aligned}$$

If three of the resistances are known, the fourth is readily calculated.

Bridge measurements divide into two classes, depending upon whether direct or alternating current is used as a source. Direct current is used only in resistance measurements. A storage battery or other convenient source of direct current is required to

supply the bridge. The voltage of the source is determined by the resistance in the circuit, and the safe wattage dissipation of the bridge arms. The sensitivity of the bridge increases with the applied voltage. A direct-current galvanometer, protected by a suitable shunt, is used as a null indicator.

GENERAL RADIO COMPANY

ALTERNATING-CURRENT MEASUREMENTS

A change in current is required for the measurement of inductance and capacitance. Modern practice has abandoned various forms of interrupters in favor of a steady source of alternating current which should be practically sinusoidal. For this purpose a microphone hummer is suitable if measurements are made at a single frequency, or a vacuum-tube oscillator if measurements are to be made at a number of frequencies. The following instruments, fully described elsewhere in this catalog, will be found suitable for use as sources for bridge measurements:

Type 213 Audio Oscillator (microphone hummer).....	\$32.00
Type 413 Beat-Frequency Oscillator (15-9,000 cycles).....	210.00
Type 377 Low-Frequency Oscillator (65-70,000 cycles).....	350.00

The impedance network for alternating-current measurements is subject to a variety of modifications of the simple bridge circuit, depending on the particular requirements of the problem. A number of such bridges are described in the following pages.

If measurements are made at audio frequencies the most sensitive form of null indicator is the telephone. The impedance of the telephone should approximately equal the impedance of the bridge for maximum sensitivity. Where telephones of the proper impedance are not available, an impedance-adjusting transformer may be used to adapt the bridge impedance to that of the telephones. A wide variety of suitable transformers for this work is listed in the transformer section of this catalog. A suitable telephone headset is listed below.

Western Electric Receiver Type 1002-C.....	\$12.00
--	---------

The sensitivity of the bridge will also be increased by the use of an amplifier between the bridge and the telephones. This is particularly recommended in factory testing where there is considerable noise present and where speed is a factor. When using a source such as the General Radio Type 213 Audio Oscillator, a filter between the bridge and the telephones is also advisable.

If bridge measurements are to be made at commercial frequencies the telephone is not a satisfactory null indicator, owing to the comparative insensitivity of both the telephone and the ear at such frequencies. For this work a vibration galvanometer is recommended. At 60 cycles the General Radio Type 338-G Galvanometer is a satisfactory null detector where very great sensitivity is not required.

Type 338-G Galvanometer	\$160.00
-------------------------------	----------

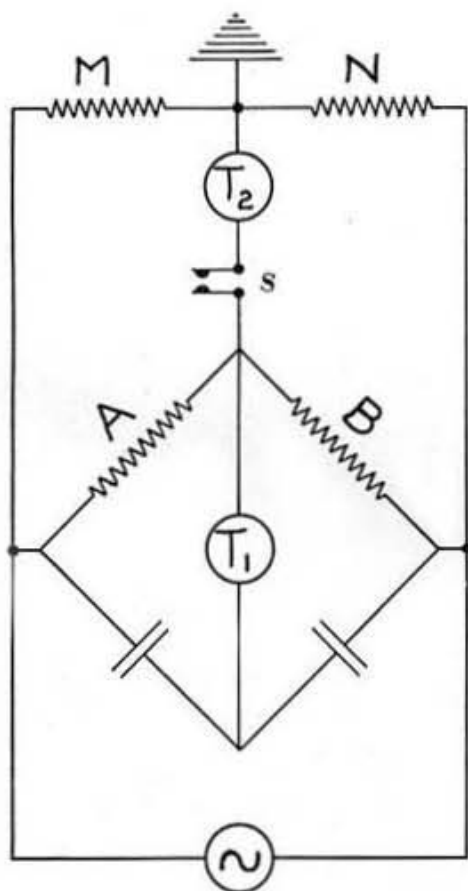

When using telephones and an audio-frequency source, trouble may be encountered in balancing the bridge, due to a charging current flowing in the telephones in consequence of a difference in potential between the observer and the telephones. This trouble may readily be overcome by the use of a transformer with a shield between the primary and secondary. Where a transformer is not available, the Wagner Earth connection, illustrated in the diagram, may be used to bring the telephones to ground potential.

The extra circuit consists of two resistances M and N which may be decade boxes of about the same total resistance as the bridge arms, an additional telephone set and a switch. The junction of M and N is grounded. With the switch S

open the bridge is balanced as closely as possible in the usual manner. The switch is then closed and the secondary bridge A-B-M-N balanced, using the telephones T2 as a null indicator. All adjustments are, of course, made on M and N so as not to disturb the setting of the main bridge. With the secondary bridge balanced, telephones T1 are at earth potential, and the final balance on the main bridge may be obtained with the switch open.

Numerous modifications of the fundamental bridge circuit are required to meet specific requirements. The General Radio Company manufactures a line of bridges to meet the requirements of communication work which are described in the following pages.

TYPE 210 RATIO ARM BOX

The simplest type of bridge is made up from a set of ratio arms together with a suitable standard, the unknown forming the fourth arm of the bridge. The use of ratio arms instead of a permanent bridge set-up

GENERAL RADIO COMPANY

provides for the greatest possible utility of equipment in the small laboratory.



The Type 210 Ratio Arm Box consists of two similar arms, each having 1000 ohms total resistance, tapped at 1-3-10-30-100-300 ohms. The resistances are of the Ayrton-Perry type. This type of resistance, described in another section of this catalog, is practically free from inductance and capacitance effects at audio frequency. The current-carrying capacity is 50 milliamperes and the adjustment accurate to within 0.1%. The dial switches are of the multi-leaf type, assuring low and constant resistance. The cabinet is of walnut with bakelite panel. All metal parts are nickel plated.

Type 210 Ratio Arm Box.....\$28.00

Dimensions $7\frac{1}{2}$ " x 5" x 4". Weight $2\frac{3}{8}$ lbs.

Code Word: RABID.

TYPE 193 DECADE BRIDGE

The Type 193 Decade Bridge is designed as a utility bridge. It is adapted to general bridge measurements of resistance, inductance and capacitance outside the field of special purpose bridges. The bridge circuit shown on Page 46 consists of three resistance arms, of the non-inductive type.

RESISTANCE MEASUREMENTS. In making measurements of resistances the null indicator is connected between points 1 and 2, and the STD posts connected together. Rc is used as the resistance standard. The

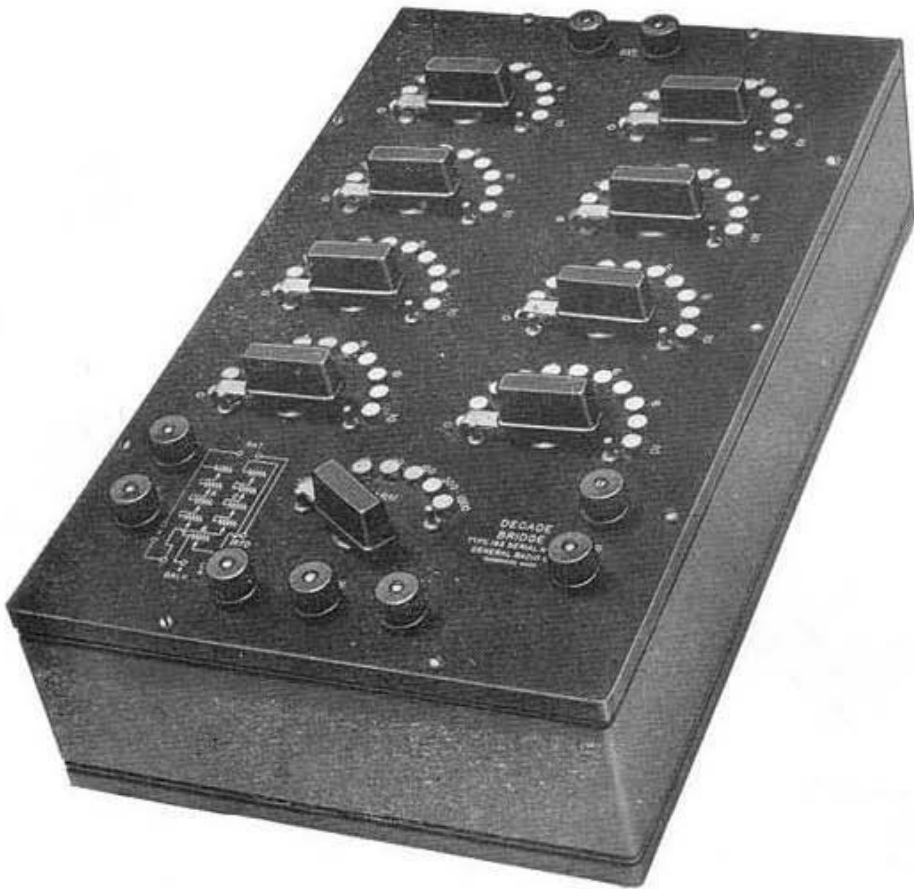

unknown is connected at X and the bridge balanced. The solution of the network gives the equation:—

$$R_x = \frac{R_A R_C}{R_B}$$

This method is suitable for the measurement of either direct or alternating-current resistance, a suitable source being connected at E. The accuracy of the bridge for resistance measurements is to within 0.2%, if proper care is exercised by the operator.

INDUCTANCE MEASUREMENTS. In inductance and capacitance measurements, the bridge must be balanced for resistance as well as for reactance. The third resistance arm R_C is used to obtain a resistance balance of the bridge. Since R_C must be connected in the arm having the lower resistance (standard or unknown) and this is not generally known in advance, it is desirable to set the bridge up with a switch so arranged that the null indicator may be readily transferred from 1 to 3, placing R_C in either arm. The bridge is balanced, the condition of zero current in the

GENERAL RADIO COMPANY

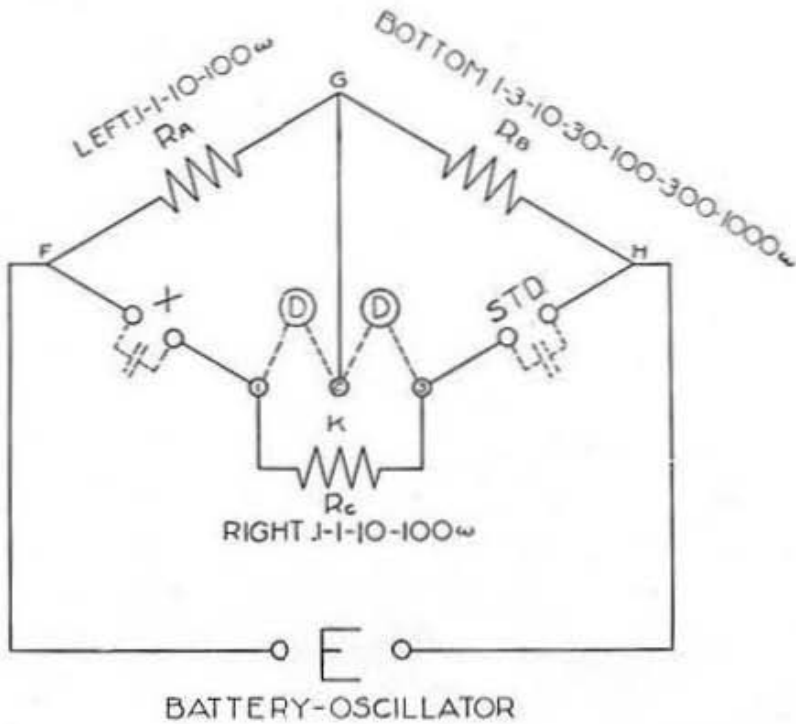

null indicator requiring simultaneous balance of both resistance and inductance. The solution of the network gives the equation for the unknown inductance

$$L_x = \frac{R_A L_s}{R_B}$$

The resistance balance gives the relation:—

$$R_x = \frac{R_A (R_s + R_c)}{R_B}$$

if R_c was connected in series with the standard or:—

$$R_x = \frac{R_A R_s}{R_B} - R_c$$

if R_c was connected in the unknown arm.

The accuracy of inductance measurement is to within 0.2% for air core inductances. Owing to the change of inductance with saturation it is impossible to obtain an exact balance with iron core inductances since the degree of saturation changes with every adjustment. The error is consequently greater in this type of measurement. The range for inductance measurement is from about 20 microhenrys to several henrys.

GENERAL RADIO COMPANY

An inductance may be compared with a capacitance by connecting the capacity across R_A . The unknown inductance is connected at the STD posts, the null indicator to 2 and 3, and the X posts connected together. The solution of this network gives the equation

$$L_x = R_B R_c C$$

The Type 106 Inductance Standards described on Page 36 are satisfactory for use with this bridge.

CAPACITANCE MEASUREMENTS. The Type 193 Decade Bridge is also suitable for the measurement of comparatively large capacitances, where extensive shielding is not required. For capacity measurements the bridge is set up with a switch for transferring R_c from the standard to the unknown arm as before. The unknown condenser is connected at X and a standard capacitance at STD. When there is no current flow through the null indicator the bridge is balanced for both capacitance and resistance. The capacity balance gives the equation:

$$C_x = \frac{R_B C_s}{R_A}$$

Since the bridge is in balance for resistance as well as capacitance the resistance equations follow as before.

$$R_x = \frac{R_A (R_s + R_c)}{R_B}$$

if R_c was in the standard arm, or

$$R_x = \frac{R_A R_s}{R_B} - R_c$$

if R_c was in the unknown arm.

The accuracy of the bridge for capacity measurement is to within 0.2%. The range is from 0.01 microfarad to several microfarads.

GENERAL DESCRIPTION. The elements of the bridge circuit shown on Page 46 are mounted in a walnut cabinet with a hard rubber panel. A dust cover is furnished to protect the bridge when not in use. The resistance units are of the Ayrton-Perry non-reactive type. The current-carrying capacity of the one-tenth ohm units is one ampere; that of the one ohm units, 250 milliamperes; that of the ten ohm units, 100 milliamperes; and that of the one hundred to one thousand ohm units, 50 milliamperes. The cabinet is copper lined to provide shielding. All exposed metal parts are nickel plated.

Type 193 Decade Bridge.....\$115.00

Dimensions 17" x 10½" x 5". Weight 13¼ lbs.

Code Word: BIGOT.

GENERAL RADIO COMPANY

TYPE 216 CAPACITY BRIDGE



For precise measurements of small capacitances or accurate determination of dielectric losses the ordinary type of bridge is unsatisfactory, since the stray capacitances in the circuit are of the same order of magnitude as the capacitance to be measured. A bridge for the measurement of small capacitances requires complete shielding of all its elements.

The Type 216 Capacity Bridge has been designed for this type of measurement. The elementary circuit is similar to that of the Type 193 Decade Bridge, consisting of three resistances, two ratio arms and a power factor resistance. The cabinet containing the bridge is copper lined and divided into several shielded compartments.

In order to isolate the bridge from stray capacitance effects transformers with grounded shields between primary and secondary are used both at the input to the bridge and at the null detector.

Since this bridge is designed for the measurement of small capacitances where the substitution method is used with equal total capacitances in the bridge arms, the ratio arms are equal resistances. The use of equal arms without switches makes a very accurate adjustment of the resistances possible. Since the arms are identical, any slight changes of power factor with frequency will balance and produce no resultant error. The third resistance arm may be connected in series with either capacity arm as required to balance the bridge. A switch *F* is provided for convenience in making the change. This resistance is one of our standard non-reactive decade boxes, mounted in a shielded compartment.

It is very often desirable to calibrate a vernier condenser whose total capacitance is of the order of 3 or 4 MMF. For this work the bridge is first balanced, using capacitances of the order

GENERAL RADIO COMPANY

of 1000 MMF. If one of the resistance ratio arms were to be increased one part in one thousand, i. e., from 5000 to 5005 ohms, the ratio of the capacitances would be changed accordingly, which is a change of 1 MMF. In order that the ratio arms may be changed in this manner, resistance units are supplied with the bridge. These units may be added to either ratio arm. Although the standard equipment of each bridge includes three of these resistance units so as to give ratios of unbalancing of 0.001, 0.01 and 0.1, they can be furnished to give any ratio desired.

Since the impedance of small capacitances at 1000 cycles is high—that of 1000 MMF. being 160,000 ohms—it is desirable that a high impedance detector be used to denote the balance point of the bridge. As the impedance at 1000 cycles of a pair of sensitive telephone receivers is only of the order of 20,000 ohms, it is evident that this is too low. For this reason an impedance-adjusting transformer, designed to work between an impedance of 200,000 ohms and an impedance of 20,000 ohms, is used. This arrangement provides the correct impedance in both the bridge and the telephone circuits and makes it possible to detect a very small difference in potential, such as that caused by the unbalancing of the condenser arms to the extent of one-hundredth of a micromicrofarad.

In order to prevent errors due to capacitance between the observer and the telephones, a grounded shield is used between the primary and secondary of this transformer. The junction of the two resistance arms is also grounded.

The accurately calibrated decade resistance arm provided for power factor measurements is valuable as a means of measuring dielectric losses.

OPERATION. A complete book of instructions, outlining the procedure for various types of measurement, is supplied with each instrument.

USES. The Type 216 Capacity Bridge is adapted to the measurement of capacitances up to about 0.5 MF. with great accuracy. The bridge is capable of indicating an unbalance of one-hundredth of a micromicrofarad. The probable error of measurement using the Type 222 Precision Condenser is about 1 MMF. When greater accuracy is required an accurately calibrated condenser of small capacity should be connected across the Type 222 Precision Condenser. As most errors come from stray fields and moving leads, a permanent and substantial set-up is necessary for accurate work.

The bridge is also suited to the determination of the power factor of dielectrics. The resistance adjustment may be made to one ohm (although the impedances measured are often in the neighborhood of 200,000 ohms). This single ohm, however, may be a considerable percentage of the change

GENERAL RADIO COMPANY

of resistance R_c and for this reason from 5% to 10% is a conservative figure for the accuracy of resistance measurements.

The testing of small samples of cable or the study of temperature changes in dielectrics is made easy because of the sensitivity of this instrument. An example of this latter use is a test made on a sample of hard rubber. The sample, which was three inches square and one-half inch thick, was placed between two metal plates. At 54° F. this sample had a capacitance of 11 MMF. and a phase angle of 48'. When heated to 100° F. the capacitance had increased to 12 MMF. and the phase angle to 1° 55'.

For the usual run of capacitance and power factor measurements, the Type 213 Audio Oscillator is suitable as a source. Where measurements are to be made over a wide range of frequencies the Type 377 Low-Frequency Oscillator is available. This instrument offers a range extending from the upper commercial frequencies, through the audio and carrier frequencies and into the radio frequencies.

The bridge circuit is mounted in a walnut cabinet and very thoroughly shielded. The resistance box is in a separate shielded compartment. The panel is of bakelite and all exposed metal parts are nickel plated.

Type 216 Capacity Bridge.....	\$175.00
Dimensions 15" x 14" x 7". Weight 19¼ lbs.	
Code Word: CIVIC.	
Type 213 Audio Oscillator.....	\$32.00
Dimensions 6" x 4¾" x 5". Weight 4½ lbs.	
Code Word: AUGER.	
Type 222 Precision Condenser Max. Cap. 1500 MMF.....	\$90.00
Dimensions 9" x 8½" x 10". Weight 15 lbs.	
Code Word: COPAL.	
Type 246-L Balancing Condenser Max. Cap. 1500 MMF.....	\$38.00
Dimensions 7½" x 7½" x 8¼". Weight 9 lbs.	
Code Word: CEDAR.	

TYPE 383 CAPACITY BRIDGE

Certain classes of capacitance measurements where accurate determination of power factor is not important can be obtained with simpler forms of bridge than the Type 216 Capacity Bridge. In the design of delicately adjusted receivers it is necessary to give considerable attention to the inter-electrode (grid-filament, plate-filament, and grid-plate) capacities of vacuum tubes. For this reason, the measurement of these capa-

GENERAL RADIO COMPANY



cities is of particular interest both to tube and to receiver manufacturers. The very small capacities involved, about 5 MMF., render the usual type of bridge measurement not very satisfactory for this use. The Type 383 Portable Capacity Bridge is particularly designed for this type of work.

A conventional type of bridge circuit, as shown below, is used, consisting of two resistance and two capacity arms. It is actuated by a self-contained microphone hummer supplied from a 4.5-volt dry battery. The output from the hummer, of about 800 cycles frequency, is fed through a transformer to the bridge circuit. The transformer has a shield between its primary and secondary, and is in addition wound in two sections so as to reduce capacity effects. The phones are supplied from another transformer, whose primary is connected across the bridge, and whose secondary is brought out to the lower terminals as shown in the photograph. Three adjustments appear on the bridge panel, marked LOSS ADJ., ZERO ADJ., and CAPACITY. These cor-

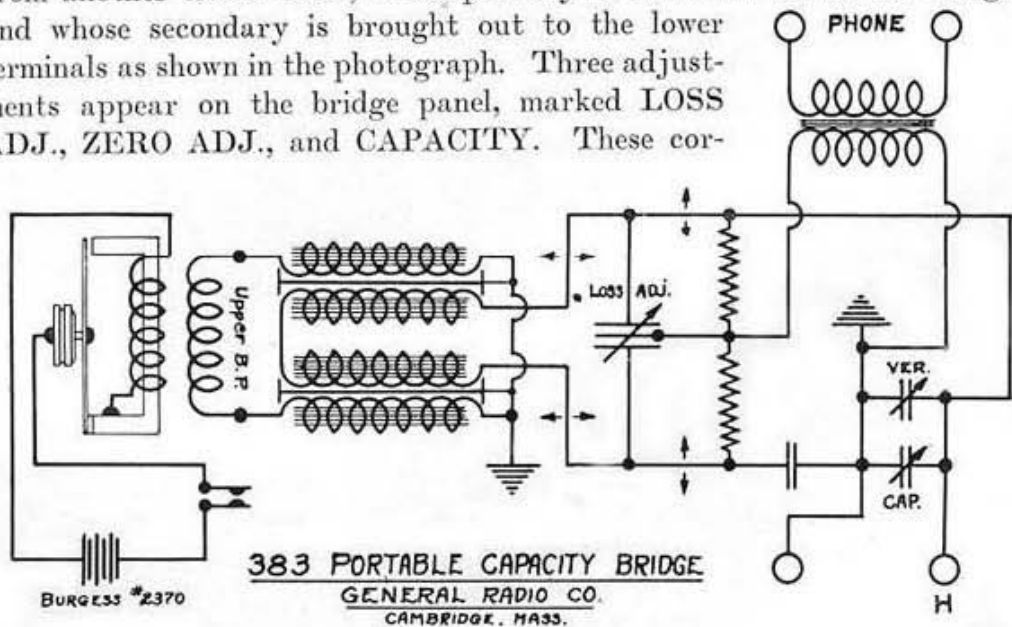

respond to the condensers labelled LOSS ADJ., VER., and CAP., respectively in the diagram. The LOSS ADJ. condenser, shunted across the

GENERAL RADIO COMPANY

resistance arms of the bridge, compensates for the variation from zero of the power factor of the unknown capacity. This adjustment is not calibrated as it is not intended for use as a means of measuring power factor. It is intended merely to compensate for loss current in the condenser arm which might otherwise render a balance of the bridge impossible. It is generally necessary to make this adjustment only when rather high loss is associated with the capacity under test. The ZERO ADJ. condenser is included across the balancing condenser and the unknown in order to balance out stray capacities of leads, sockets, etc. Since the ratio arms and standard condenser are fixed, the total capacity in the fourth arm of the bridge, which includes the unknown with its leads, the zero-adjusting and the measuring condenser must be constant for balance. In making measurements the leads, sockets, or other apparatus associated are connected to the terminals and the capacity of the ZERO ADJ. condenser reduced sufficiently to balance the bridge with the CAP. condenser set at maximum capacity. The dial on this condenser is set to read 180 degrees out of phase with the capacity, i.e., the dial is set at 0 for maximum capacity.

The unknown capacity is then connected and the condenser marked CAP. rotated (reducing its capacity) until the bridge is again balanced. The LOSS ADJ. condenser is adjusted as required in each case. The capacity of the unknown condenser is obtained by multiplying the reading of the measuring condenser by a factor appearing on the dial.

A very convenient accessory in making measurements on the inter-electrode capacities of vacuum tubes is the socket shown in the foreground of the photograph. This socket is equipped with three plugs so spaced as to fit the binding posts of the bridge, and connected to grid, plate, and filament. In measuring the tube capacities, this socket is plugged in and the bridge balanced for zero. The tube is then placed in the socket and its capacities measured directly.

Readings can be made to about one-half division on a one hundred division scale with telephones, or somewhat more accurately if an amplifier and vacuum-tube voltmeter are used.

The Type 383 Capacity Bridge is made in two models. One, with a range extending to 30 MMF., is designed for the measurement of small capacities. Another, with a range extending to 600 MMF., is particularly useful in matching condenser units for use in single control setups. The accuracy of the instrument makes it very useful for this purpose, as it will show up differences of less than 1 MMF. between such units. Its simplicity in comparison with the quartz-controlled oscillators

GENERAL RADIO COMPANY

and other expedients resorted to for condenser matching recommends it strongly.

A very useful adjunct to the capacity bridge is a two-stage amplifier. A vacuum-tube voltmeter such as the Type 426-A Thermionic Voltmeter can then be used to detect balance and a somewhat greater accuracy attained than is possible with earphones. Another advantage of the voltmeter is that it permits tolerance limits to be marked on the dial of the voltmeter, a useful practice in factory inspection work.

The Type 383 Capacity Bridge is mounted in a copper-lined walnut case with a metal panel. All exposed metal parts are nickel plated. A 4.5-volt battery is supplied with the bridge.

Type 383-A Portable Capacity Bridge (30 MMF.).....\$80.00
Code Word: BRUIN.

Type 383-B Portable Capacity Bridge (600 MMF.).....\$80.00
Code Word: BUGLE.

Dimensions both types 18" x 6 $\frac{1}{8}$ " x 6 $\frac{1}{2}$ ". Weight 14 $\frac{3}{4}$ lbs.

TYPE 240 CAPACITY METER



For test work a direct-reading bridge of fair accuracy is of great convenience. The Type 240 Capacity Meter is designed to fulfill this need. It is especially adapted to general laboratory and commercial uses in obtaining capacitance measurements ranging from 0.001 to 10 MF. with an accuracy to within 0.5%. Its simplicity of operation and general

GENERAL RADIO COMPANY

dependability make it invaluable in factory inspection work in measuring or comparing capacitance values.

The instrument consists of a capacity bridge with variable resistances in the ratio arms and capacitances in the unknown and standard arms. A schematic diagram of the whole assembly is shown below. The input is from a specially designed microphone buzzer supplied from a 4.5-volt dry battery contained in the case. Provision is also made for the use of an external battery.

The resistances M and N are wound on thin bakelite strips to reduce distributed capacity and inductance. R is a rheostat of 120 ohms resistance.

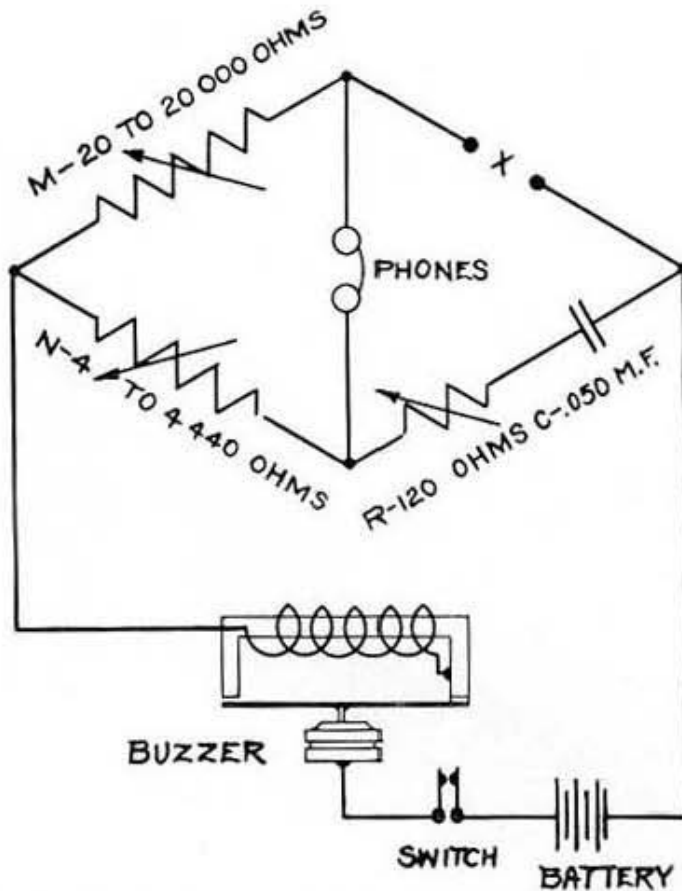

The standard condenser C is built up of copper plates interspaced with mica dielectric, assembled under pressure and impregnated with paraffin. It is firmly clamped in a heavy brass frame.

OPERATION. Before operating the meter it is necessary to put the battery in place as follows: Remove the four screws at the corners and lift the panel out. The battery is then slipped under the holder so that

GENERAL RADIO COMPANY

the terminals make contact with the metal strips on the ends of the buzzer leads. The panel may now be put back in place and the instrument is ready for operation.

The unknown capacity is connected to the two clips (at X in the diagram). The three dials marked MICROFARADS, TENTHS, HUNDREDTHS, and the dial marked MULTIPLY BY are set approximately at the capacitance to be measured, if its order of magnitude is known. The buzzer switch is turned on and the dials are set, beginning with the dial marked MICROFARADS, and adjusting the three lower dials in turn until the minimum sound is heard in the receivers, then adjusting the dial marked POWER FACTOR until the sound heard in the receivers is still further reduced, readjusting the capacity dials, if necessary.

The capacitance is read on the three lower dials, beginning at the left. The reading of the dials times the multiplier is the capacitance in microfarads. The per cent. power factor is read from the POWER FACTOR dial. For greatest accuracy the multiplier dial should be set as follows:

For capacities from:

1.0	to	10.0	MF. multiply by 1
0.1	to	1.0	MF. multiply by 0.1
0.01	to	0.1	MF. multiply by 0.01
0.001	to	0.01	MF. multiply by 0.001

If the meter is to be stored or shipped the battery should be removed, otherwise the electrolyte in the battery may seep out and damage the meter.

USES. The capacity meter is especially adapted to all uses where a convenient, rugged, and reliable instrument is desired for general laboratory and commercial use in measuring capacitances. It is particularly suited to the use of manufacturers of condensers for an inspection instrument whereby condensers may be tested quickly and accurately. When condensers supposedly of the same capacitance are being measured it is necessary only to vary the setting of one of the capacity switches within the limits of the tolerance allowed. The power factor dial offers a ready means of detecting condensers with high losses. Because of its simplicity of operation this instrument does not require a skilled operator and will not easily get out of order.

The bridge circuit is enclosed in a walnut cabinet with a leather carrying handle. The panel is of hard rubber. The resistance switch has double-leaved blades. All metal parts are nickel plated. A pair of

GENERAL RADIO COMPANY

telephones is supplied with the bridge in a compartment provided for them. A battery is also supplied.

Type 240 Capacity Meter.....\$85.00

Dimensions 7" x 6" x 14½". Weight 10⅞ lbs.

Code Word: CYNIC.

TYPE 361-B VACUUM-TUBE BRIDGE



A bridge for the measurement of tube constants is not the conventional type of impedance network. This type of bridge depends on the balancing of the amplified signal voltage in the plate circuit by an opposing voltage. A null point is indicated by telephones and the balancing process is similar to that of the standard bridge circuits.

The uses of the three-electrode vacuum tube have become so manifold that the study of its various characteristics is of considerable importance. Several tube-testing devices have been developed and placed on the market. These usually consist of a series of meters and rheostats, with or without enclosed batteries, and are designed to check filament power and to measure certain so-called "static characteristics," such as the joint emission to grid and plate or the steady plate current passing under any particular conditions of filament current or voltage, plate voltage and DC. grid bias. From characteristic curves obtained in this manner, the "static amplification constant" and other data of value may be determined. Under certain conditions, however, the "dynamic characteristics" of a tube are of more fundamental importance. To obtain

GENERAL RADIO COMPANY

such data it is necessary to apply an AC. potential to the grid of the tube and to make use of certain balanced-bridge measurements.

The General Radio Type 361-B Bridge was developed to furnish an instrument which would not only provide for the easy and rapid measurement of filament emission and certain so-called "static characteristics", but would also act as a direct-reading bridge giving three fundamental "dynamic characteristics" of the tube, namely: the Amplification Constant, the Plate Resistance, and the Mutual Conductance. To measure these dynamic constants the bridge must be supplied with current from

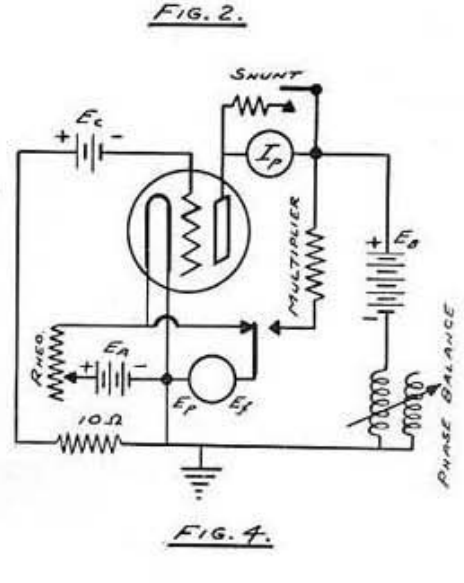
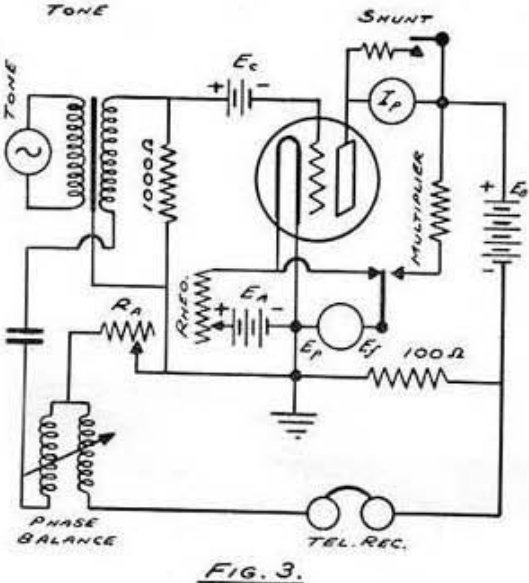
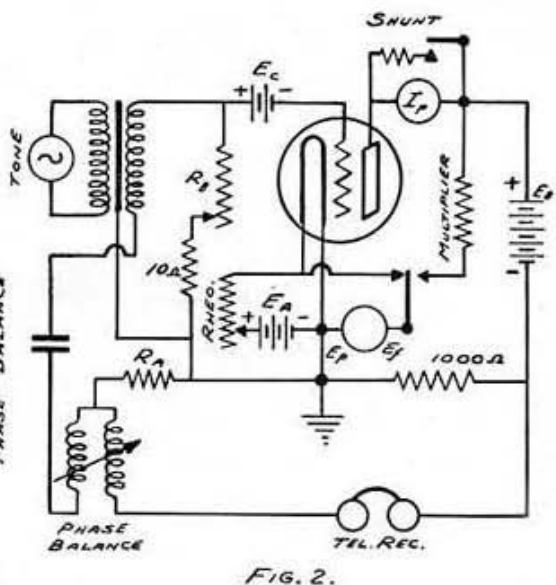
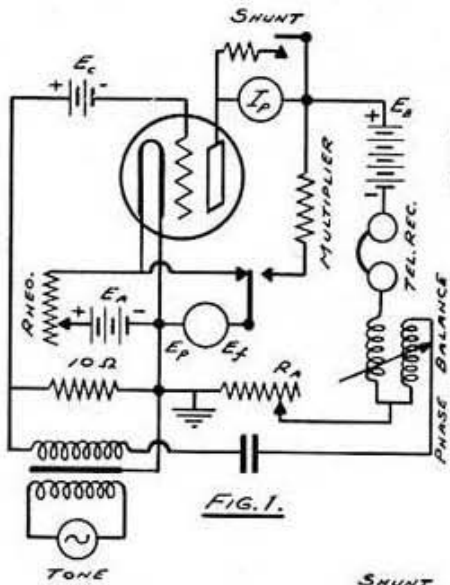

GENERAL RADIO COMPANY

an audio-frequency tone source, preferably sinusoidal in character, and then be balanced for a null setting in the telephone headset in the manner of the ordinary impedance bridge. The Type 213 Audio Oscillator makes an excellent tone source for this purpose.

The bridge is designed to combine accuracy with great ease and speed of manipulation. All changes in the bridge to obtain the different circuits used are made by means of throw switches. The balancing adjustments are on a dial-decade scheme.

The tube to be measured is inserted in a detachable socket, mounted externally on the panel of the bridge. A 10-volt Weston meter is provided for measuring the voltage directly across the filament terminals and, by means of a multiplier, the plate battery voltage. A Weston 5-milliamperere meter is used for measuring the plate current. This is equipped with a shunt extending its range to 25 milliamperes. Provision is made for inserting any desired grid battery in the grid circuit. Thus, by varying the filament voltage, plate voltage, and grid bias (all by means external to the bridge), the data for the customary "static characteristic curves" may be read conveniently on the bridge meters. Routine inspection tests at definite voltages are, of course, quickly and easily performed.

The bridge is equipped with three telephone keys and two four-dial resistance arms, the proper manipulation of which enables the operator to determine quickly the three dynamic characteristics mentioned above for any particular specifications of filament voltage, plate voltage and grid bias. Thus, in a similar manner, the "dynamic characteristic curves" of a particular tube may be obtained easily and rapidly and research or routine inspection work greatly facilitated.

The resistances are of the non-inductive, low distributed capacity type, and the bridge is adequately shielded. The input transformer has a shield between its two windings.

The units constituting the bridge may be arranged in any of the accompanying circuits by manipulation of the key switches.

The Type 361-B Vacuum-Tube Bridge is designed to measure AC. as well as DC. tubes.

The precision of results obtained from the bridge may be improved by the substitution of a resistance of 100 ohms for the telephones, and the use of an amplifier for balancing. This reduces the effect of telephone impedance and direct-current resistance drop through the telephones to that of the 100-ohm resistance.

The circuit of Fig. 1, obtained by throwing in the key marked AMPLIFICATION CONSTANT, provides for the direct measurement

GENERAL RADIO COMPANY

of the voltage amplification constant of the tube under test. The resistance R (the four-dial A-arm of the bridge) is adjusted until the drop through it due to current from the tone source balances the potential μE_g resulting in the plate circuit from voltage E_g impressed on the grid. Minimum tone in the telephones indicates the balance point. E_g results from the flow of the current from the tone source through the 10-ohm resistance in series with R_A .

In order for no current to flow:

$$E_p = \mu E_g = R_A I_T$$

Where I_T is the current from the tone source

μE_g is opposite in phase to $R_A I_T$

$$E_g = 10 I_T$$

$$\mu = R_A / 10$$

The resistance R_A is numerically equal to 10μ , and the decade resistance system is calibrated directly in terms of amplification constant.

A variometer, by means of which the quadrature component of the e.m.f. introduced by the tube capacity may be balanced out, greatly facilitates the balance. The constant may be read to two decimal places. The resistance provides for the measurement of amplification constants up to 100.00.

To measure plate resistance the bridge is set for the circuit of Fig. 2. The value of amplification just determined is set on the A-arm, and the bridge is balanced by adjusting the four-dial B-arm. It will be noted that R_A has been switched to the grid circuit and replaced by the 1000-ohm resistance. R_B has been added in the grid circuit. The condition of balance requires that the drops across the 1000-ohm plate resistance and R_A be equal.

At balance:

$$R_A I_T = 1000 I_P$$

$$I_P = \mu E_g / (R_P + 1000)$$

$$E_g = I_T (R_B + 10)$$

Substituting and dividing:

$$R_A = 1000 (R_B + 10) \mu / (R_P + 1000)$$

But:

$$\mu = R_A / 10$$

Hence:

$$100 (R_B + 10) / (R_P + 1000) = 1$$

Giving:

$$R_P = 100 R_B$$

R_B is calibrated to read directly in plate resistance.

As before, use is made of the variometer in balancing out the quadrature component in an accurate adjustment of the bridge. Measurement may

GENERAL RADIO COMPANY

be made of plate resistances up to 100,000 ohms in 10-ohm steps.

For the measurement of mutual conductance, the bridge circuit is transformed to that of Fig. 3 (the 1000-ohm plate resistance of Fig. 2 is reduced to 100 and the grid resistance becomes 1000). Balance is obtained by adjusting R_A and the variometer.

$$\begin{aligned} \text{At balance: } R_A I_r &= 100 I_p = 100 \mu E_g / (R_p + 100) \\ E_g &= 1,000 I_r \\ R_A &= 100,000 \mu / R_p \quad (R_p \text{ is large compared to } 100). \\ \mu &= R_A R_p / 100,000 \\ \text{Mutual conductance} &= \mu / R_p = R_A / 100,000 \end{aligned}$$

Since the A-arm is marked with 1/10 of its true resistance:

Mutual conductance in mhos = reading of A-arm $\times 10^{-4}$.

Values up to 0.01 mho may be read in steps of one micromho.

It should be noted that some error is involved in the assumption that R_p is large, compared to 100. This error may become quite great when measuring tubes of low plate resistance. The percentage error is $100/R_p$. The bridge reading is less than the true value of mutual conductance.

Fig. 4 is the circuit for taking the static characteristics. The voltmeter is normally connected across the filament. Depressing a switch connects it across the plate battery, and throws in a multiplier. The maximum reading is 200 volts. The ammeter is provided with a shunt, reading either 5 or 25 milliamperes maximum. A button type of switch controls the shunt.

A pamphlet of instructions is supplied with the bridge.

Type 361-B Vacuum-Tube Bridge.....\$220.00

Dimensions 16" x 14" x 8". Weight 21 lbs.

Code Word: BIBLE.

The bridge price includes sockets for the UX and UY-base tubes. UV-base adapter sockets may be obtained as follows:

Type 361-40 For use with large UV-base

Type 361-41 For use with small UV-base

Price, either type \$3.00

TYPE 443 MUTUAL-CONDUCTANCE METER

Of the three fundamental dynamic constants of the three-element vacuum tube (plate impedance, amplification factor, and mutual conductance), the mutual conductance gives the most positive indication of the tube behavior, since it involves the ratio of the other two constants. While the mutual conductance is not a complete indication of the com-

GENERAL RADIO COMPANY

parative merit of tubes of differing types, it is a positive indication among tubes of the same type. If a tube fails to meet the standard specifications of its type, either through faulty filament emission or an incorrect spacing of the elements, the mutual conductance always will be lowered. Since the



mutual conductance is very easily measured, this constant is the one most suited for use as an acceptance standard for purchasers, and for use in factory, store or laboratory for rapid checking of tubes against a standard value. This device should not be confused with the Type 361-B Vacuum-Tube Bridge, which is a laboratory instrument designed to give accurate measurement of all three constants.

The Type 443 Mutual-Conductance Meter is a null-point bridge instrument excited by a self-contained microphone hummer and battery. A standard UX-type of socket is provided as well as a socket for the five-prong separate heater tubes. All tube batteries are external. Any desired plate voltage may be applied to the tube as well as any desired grid biasing voltage. The instrument is equipped with a voltmeter for indicating the voltage across the filament. By the use of one or the other of the rheostats mounted on the panel it is possible to adjust the filament voltage to the correct value for any standard tube. A pair

GENERAL RADIO COMPANY

of telephones is used as a null indicator. If the bridge is operated in a noisy environment an external stage of amplification will be found desirable.

Values of mutual conductance having a precision of within 5% are quickly obtained by the manipulation of a single dial to give silence in the phones. This dial is calibrated to read mutual conductance directly in micromhos from 0 to 2500 micromhos. The dial spacing is not uniform but is so graduated as to maintain an approximately equal percentage precision of reading over the entire scale.

Price does not include battery. A 4.5-volt battery is required.

Type 443 Mutual-Conductance Meter.....\$55.00
 Dimensions 10" x 10" x 4½". Weight 6½ lbs.

Code Word: MUCUS.

The following list of representative values of mutual conductance for various types of standard tubes were obtained with the Type 443 Mutual-Conductance Meter.

	Rheostat Used		Filament Voltage	Grid Bias	Plate Voltage	Representative
	High Current	Low Current				Mutual Conductance (Microhms)
UX-11-UX-12		X	1.1	-4.5	90	390
UX-226	X		1.5	-9.0	135	970
UY-227	X		2.25	-4.5	90	1010
UX-199		X	3.3	-4.5	90	420
UX-120		X	3.3	-22.5	135	510
UX-200-A	X		5	0	45	640
{ UX-201						
{ UX-201-A	X		5	-4.5	90	740
UX-201-B		X	5	-4.5	90	740
UX-240	X		5	-3	180	300
{ UX-112						
{ UX-112-A	X		5	-9	135	1760
{ UX-171						
{ UX-171-A	X		5	-41	180	1330
UX-210	X		7.5	-35	425	1450
UX-250	X		7.5	-84	450	1800

FREQUENCY STANDARDS

For many years the General Radio Company has been engaged in the development of independent frequency standards. Methods of measurement have been steadily and greatly improved, and the development of more accurate standards has kept pace with the development of measurement methods.

The frequency standards offered by the General Radio Company are of two classes: fundamental laboratory calibration standards for which piezo-electric oscillators are now used, and secondary standards of the resonant-circuit type. The former have recently been supplemented by magnetostriction oscillators for use at the upper audio and lower radio frequencies.

PIEZO-ELECTRIC OSCILLATORS



Type 275 Piezo-Electric Oscillator

The piezo-electric properties of crystalline quartz make it particularly well adapted for use as a frequency standard. Plates of this material, when properly prepared and placed in the circuit shown on Page 64, will hold the frequency within very narrow limits. The oscillating frequency is nearly independent of the electrical constants of the circuit. The frequency is principally dependent on the physical dimensions of the quartz plate which may be ground very closely to specifications.

GENERAL RADIO COMPANY

The General Radio Company, working in conjunction with Dr. W. G. Cady and Dr. G. W. Pierce, has developed a commercial application of this principle.

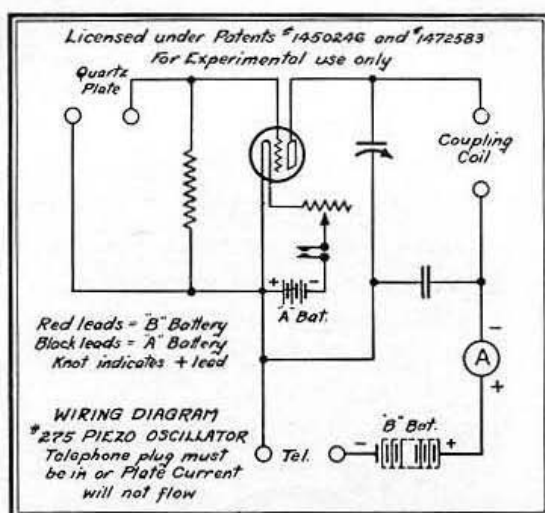

The oscillator circuit is shown above. A UX-199 tube is used as an oscillator. The meter, mounted on the front of the panel, indicates when the circuit is oscillating. The circuit between the plugs marked TEL must be closed. The tuned circuit must be adjusted approximately to the frequency of the quartz plate, or the system will not oscillate. The system will oscillate only at the frequency determined by the plate, and not at the frequency of the tuned circuit. When the plate has several frequencies of oscillation, the tuning of the vacuum-tube circuit determines at which of the frequencies the plate will oscillate. The coil is mounted externally and is suitable for coupling to other apparatus.

Limits are imposed on the fundamental frequencies for which it is possible to provide plates by physical conditions. The lower frequencies require very large plates, while for the higher frequencies the plates are very thin, difficult to handle, and fragile. The practical limits at present are about 100 and 2000 kilocycles. Lower and higher frequencies are readily obtained from these fundamentals, since the oscillator output is rich in harmonics. Reasonable care should be taken in handling the plates, as they will fracture if subjected to too great a mechanical shock.

Where it is desired to use the weaker harmonics of the tube, one or two oscillating vacuum-tube circuits may be coupled to the oscillator output, and adjusted to zero beats. If different harmonics are used for each oscillator, harmonics as high as the 300th may be utilized. Lower

GENERAL RADIO COMPANY

frequencies than the fundamental may also be obtained by means of the auxiliary tube. The auxiliary tube is adjusted to the lower fre-

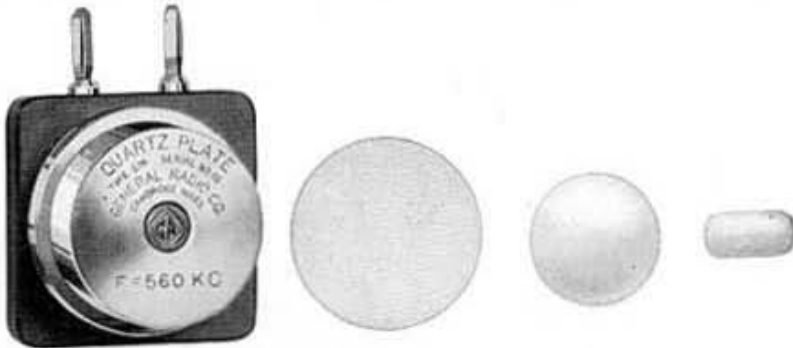

quency by tuning it for zero beat between its harmonic of the desired order and the quartz-controlled oscillator. By means of this device, a single plate may be used to obtain a great number of frequencies.

TYPE 275 PIEZO-ELECTRIC OSCILLATOR

In the General Radio Type 275 Piezo-Electric Oscillator the principle of frequency control by the use of quartz crystals has been made available for general experimental use. The Type 275 Piezo-Electric Oscillator is intended primarily for a frequency standard. As such it offers numerous advantages over the ordinary standard wavemeter as a primary standard. The entire equipment is considerably less bulky than the wavemeter, and the essential standard of frequency, the quartz plate, is of vest-pocket dimensions. The frequency of the piezo-electric oscillator is determined almost entirely by the constants of the quartz plate and holder and therefore is maintained practically constant, once the physical dimensions are fixed.

The instrument is entirely self-contained and consists of the components shown in the wiring diagram, mounted in a suitable cabinet which has space for all necessary batteries. Since the plate is mounted on the front of the panel with a plug-in arrangement, plates may be readily exchanged in order to extend the frequency range.

Type 275 Piezo-Electric Oscillator \$60.00

Dimensions 10" x 11" x 8". Weight 9 $\frac{3}{4}$ lbs.

Code Word: LABEL.

TYPE 375 STATION PIEZO-ELECTRIC OSCILLATOR

For broadcasting station use there has been developed the Type 375 Station Piezo-Electric Oscillator. This instrument incorporates an oscillator, similar to the Type 275 Piezo-Electric Oscillator, and a two-stage amplifier. The addition of the amplifier makes this unit suitable for

GENERAL RADIO COMPANY

monitoring in the operating room. When the Type 375 Station Piezo-Electric Oscillator is placed in the operating room, and connected to a loud-speaker, the beat note becomes plainly audible when the station frequency differs from that of the standard.

Licensed under U. S. Patents Nos. 1,450,246 and 1,472,583 for experimental use only.

Type 375 Station Piezo-Electric Oscillator, including two-stage amplifier.

Price, without plate \$100.00

Dimensions 13½" x 13" x 8". Weight 16¾ lbs.

Code Word: LATIN.

Four classes of plates are provided. Where a wavemeter standard is desired, and the exact points of calibration are immaterial, a plate can be provided without special grinding. Plates of this class are provided with the usual mounting, and the fundamental frequency, measured to within 0.1%, engraved on the cover. They can usually be supplied to within 25% of any specified frequency within the above range. By making use of harmonics, one plate may be used for a number of calibration points. Where a closer approximation to a specified frequency is desired, plates may be provided to within 5% of the required frequency. Where the requirements are still more rigid, plates may be ground to within 0.1% of the specified frequency. The calibration on all plates is to within 0.1%. This calibration is not guaranteed, however, if the plate is used to control a greater power than a type 201-A tube with normal plate voltage.

A fourth class is intended particularly for broadcast stations, which are required by Federal regulations to maintain their frequencies within 500 cycles of that assigned. These plates are furnished only with a Type 275 or Type 375 Oscillator. They are guaranteed and certified to be within 500 cycles of the specified frequency when used in the oscillator with which they are supplied. These plates are intended for use only as standards. Their high degree of accuracy will not be maintained if they are used in power oscillators.

Type 376-B Quartz Plate, mounted, ground to $\pm 25\%$ of specified frequency.

Price \$25.00

Code Word: LAGER.

Type 376-C Quartz Plate, mounted, ground to $\pm 5\%$ of specified frequency.

Price \$35.00

Code Word: LAPEL.

GENERAL RADIO COMPANY

Type 376-D Quartz Plate, mounted, ground to $\pm 0.1\%$ of specified frequency.

Price \$50.00

Code Word: LARVA.

Type 376-E Quartz Plate with certificate of accuracy to 500 cycles.

Price \$60.00

Code Word: LEGAL.

Quartz plates are also provided for amateur transmitters. These plates are not ground to specifications, but are supplied to have a frequency somewhere in the band specified. They are unmounted, but are calibrated to an accuracy of within 0.25% .

Type 276-A 160 Quartz Plate. Unmounted. For use in 160-meter band.

Price \$15.00

Code Word: LABOR.

Type 276-A 80 Quartz Plate. Unmounted. For use in 80-meter band.

Price \$25.00

Code Word: LAYER.

Type 356 Plate Holder for 276-A Quartz Plate only.....\$1.50

Code Word: LASSO.

MAGNETOSTRICTION OSCILLATORS



Type 489 Pierce Magnetostriction Oscillator

Recent laboratory researches have made possible the development of controlled oscillators for use at lower frequencies, analogous to the piezo-electric oscillators which have been in use at radio frequencies for some time. These standards are the result of recent investigations of the phenomena of magnetostriction by Dr. G. W. Pierce, of Harvard University.

GENERAL RADIO COMPANY

Just as properly prepared quartz crystals expand and contract under the influence of a varying electrostatic field, due to their piezoelectric properties, so also do rods of certain materials expand and contract under the action of varying magnetic fields by virtue of their magnetostrictive properties. Pure iron and steel, although they are strongly magnetic, show only very feeble magnetostrictive effects. On the other hand, pure nickel, which is only slightly magnetic, gives a strong magnetostrictive response. Alloys of nickel and iron in certain proportions are active, especially those having about 36% nickel and 64% iron, which is the approximate composition of invar and stoic metal. Alloys of chromium, nickel and iron, exemplified by the metal nichrome, and monel metal, which is an alloy of nickel and copper, are among the most active materials which are easily obtained. Alloys of cobalt and iron are also strongly magnetostrictive. All of these materials are improved by annealing.

If a rod of some magnetostrictive material be surrounded by a coil through which an alternating current is passing, at the peak of each half cycle the rod is magnetized and is thereby made to expand along its length, regardless of the polarity of the magnetization. Thus, the rod will expand and contract, that is, it will vibrate longitudinally, with a frequency which is twice that of the alternating current in the coil.

If, on the other hand, the rod is at the same time subjected also to a steady magnetizing force greater than the peaks of the alternating force, then the net magnetization will rise and fall with the AC. wave but will never reverse its polarity. As a result, the rod will now vibrate with the same frequency as the alternating current. If this frequency falls within the range of audition, these *forced* vibrations of the rod imparted to the surrounding air will, of course, be audible.

Instead of forcing the rod to vibrate in step with any impressed frequency, the rod can, by the use of the circuit shown in full lines in the diagram, be made to control the oscillations of the hi- μ tube T_1 to a single frequency (and harmonics thereof) corresponding to the *natural frequency of vibration* of the rod, which is inversely proportional to its length. In this manner we have controlled or standardized frequency closely analogous to the control of a vacuum-tube oscillator by means of a piezo-electric crystal.

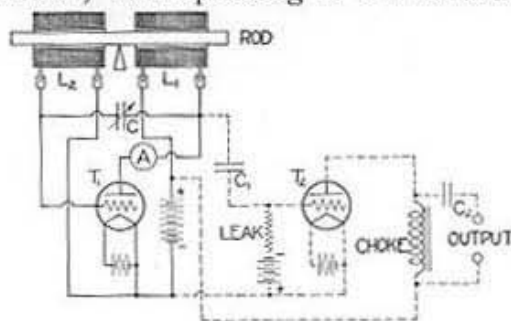

GENERAL RADIO COMPANY

The two equal coils L_1 and L_2 are inserted in the plate and grid circuits of the tube. C is a variable condenser whereby the total reactance of these coils may be resonated to the natural frequency of the rod. The coils surround but do not touch the rod, which is balanced or clamped at its center point. The direction of winding of the coils is such that filament emission currents flowing in the plate and the grid circuits would magnetize the rod with the same polarity. This is exactly the opposite of the condition existing in the familiar Hartley oscillator circuit. That is to say, the magnetostriction oscillator with the rod removed is degenerative rather than regenerative in character.

A is a DC. milliammeter giving an indication of resonant tuning of the circuit as C is varied. The dotted circuits show how, by virtue of a second tube T_2 , a stage of amplification may be added to the oscillator. The coupling condenser C_1 is of the order of 0.1 MF. The choke and 2 MF. condenser C_2 in the plate circuit of the amplifying tube constitute the familiar "speaker filter" for removing a DC. polarization from the output terminals. The grid leak is of the order of 50,000 ohms.

When such a circuit is tuned by means of C until resonance with the natural frequency of the rod is approached, the reading of A rises sharply to a maximum as the rod goes into strong vibration. When this optimum point is reached the condenser may be increased or decreased by a considerable amount, while the frequency of the oscillator remains unchanged. That is to say, the circuit is stabilized at the natural frequency of the rod.

Various types of tubes may be used at T_1 , the plate voltage may be changed from 67 to 135, or the filament voltage may vary from practically zero emission to destruction of the filament with a resultant change of less than one part in 30,000 in the stabilizing frequency of the circuit. A reasonable control of these variables gives, of course, a much more precise standardization of the frequency.

The relation between the length and natural frequency of a rod is given by the simple equation:

$$V=2 LF$$

where F is the frequency in cycles per second, L the length of the rod, and V the velocity of sound in the rod expressed in corresponding units. For a given material, V is a constant essentially independent of L and F , so a whole series of rods of definite frequencies is easily prepared. Dr. Pierce has made such a series, having fundamental frequencies varying over a wide range from a few hundred to 30,000 cycles per second. Harmonics of these frequencies up to several millions are readily detected. Since great difficulty is encountered in obtaining large enough piezo-elec-

GENERAL RADIO COMPANY

tric crystals to give fundamental frequencies below 25 kilocycles, the lower range of frequency standardization has been greatly increased by the invention of the magnetostriction oscillator. Magnetostriction rods are calibrated with much greater ease than are piezo-electric crystals, since the rods remain continually active and are not subject to the disappointing vagaries of crystals.

As the length of the rod is decreased and its frequency increased, greater stabilization is attained by occasionally reducing the inductance of the two exciting coils. This is readily accomplished by having three or four different pairs of coils mounted on jack-plugs for easy substitution in the oscillatory circuit.

Under the license to patents pending of Dr. Pierce, the General Radio Company has developed magnetostriction oscillators embodying the circuits shown in the diagram.

The Type 389 Pierce Magnetostriction Oscillator incorporates the circuit illustrated, which is supplied mounted in a cabinet without coils, rods or vacuum tubes. It includes the stage of amplification and has provision for extending the range of the condenser C, as well as other desirable control features.

The Type 489 Pierce Twin Magnetostriction Oscillator is illustrated on Page 67. It consists of two separate and complete oscillators and amplifiers mounted in a single unit, with provision for varying the capacity coupling between them. One oscillator may be controlled by a rod, while the other takes the form of a variable Hartley oscillator to be used in frequency calibration, or both oscillators may be controlled by rods, and definite fixed beats between them obtained.

Suitable coils can be supplied for any frequency in the range for which rods are furnished, or the coil unit in the Type 384 Radio-Frequency Oscillator may be employed.

Standard rods will be available in the frequency range of 10,000 to 50,000 cycles. Two classes of rods will be provided: approximate rods where no attempt is made to obtain a precise frequency, and rods prepared to within 0.1% of a specified frequency. In each case the actual frequency of the rod will be accurately determined and specified to within 0.1%.

The magnetostriction equipment is new, and the manufacturers will welcome any suggestions for changes or improvements based on the users' experience.

The oscillators are licensed under patent applications of Dr. G. W. Pierce, and under Patent No. 1,113,149 for experimental use only.

GENERAL RADIO COMPANY

- Type 389 Pierce Magnetostriction Oscillator.....\$195.00
Dimensions $12\frac{3}{4}$ " x $12\frac{3}{4}$ " x 8". Weight 18 lbs.
Code Word: MAGNETOCAT.
- Type 489 Twin Pierce Magnetostriction Oscillator.....\$275.00
Dimensions $19\frac{1}{2}$ " x $11\frac{1}{2}$ " x 8". Weight 30 lbs.
Code Word: MAGNETODOG.

Oscillators are furnished without coils, rods, tubes or batteries.

- Coils and Mounting for rod \$30.00
Rods—approximate \$25.00
Rods ground to specified frequency \$40.00

TYPE 224 PRECISION WAVEMETER

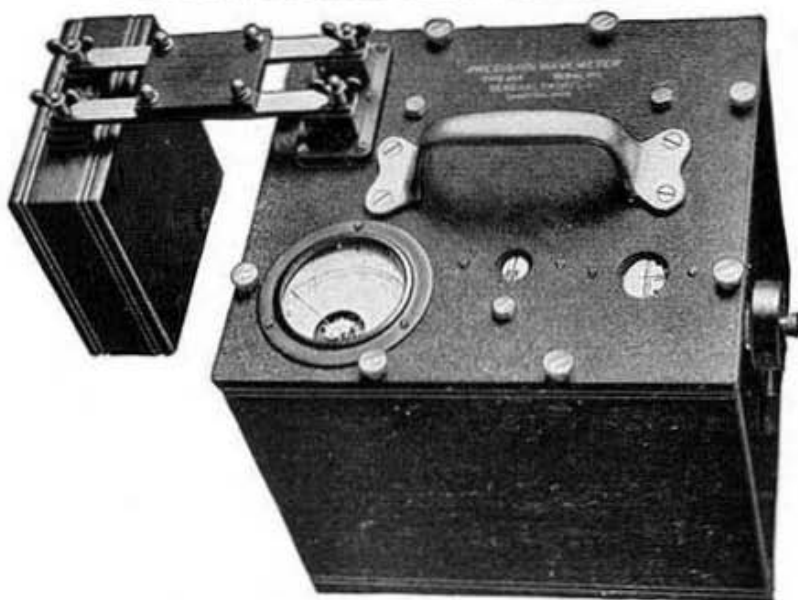

The Type 224 Precision Wavemeter has long been known as a precision standard. While newer standards have a greater precision than wavemeters of the resonance type, the precision of the Type 224 Precision Wavemeter is sufficient for many uses as a laboratory standard. An instrument of the wavemeter type is also necessary in conjunction with primary standards of the piezo-electric type as a secondary standard and transfer instrument of continuous range, since the piezo-electric oscillator provides fixed calibration points only.

This wavemeter is designed to provide an accurate instrument for laboratory service, yet is sufficiently portable for general measurement work where precision is essential.

Since the condenser is the Type 222 Precision Condenser described on Page 8, it is not necessary to describe it in detail here. The coil mounting

GENERAL RADIO COMPANY

is rugged, and particular care has been taken to lock or pin all parts to keep them secure. The coils are wound and mounted in such a manner that the turns cannot become loose.

A standard wavemeter must tune sharply. This has been accomplished in the Type 224 Precision Wavemeter by the use of a low-loss condenser and by proper inductance design. In the design of these inductances, of which there are five, attention also has been given to the necessity for low dielectric losses, low distributed capacity, good form factor, and a reasonable amount of overlap in wavelength.

To insure accuracy under all conditions no extra circuits such as a buzzer or detector are incorporated in the wavemeter. There is but one circuit, the calibrated oscillating circuit, which consists of the condenser, an inductance and a Weston thermogalvanometer for indicating resonance. This circuit is so connected that the condenser rotor plates, the condenser shield, the thermogalvanometer and the outside of the inductance coil are at low potential. This prevents disturbances due to variation in stray capacities.

The scale arrangement is the same as is used on the Type 222 Precision Condenser. Attached to the main shaft is a scale, divided into 25 equal parts, while on the worm shaft is a second scale, the circumference of which is divided into 100 equal parts. Since one complete turn of the worm shaft moves the main scale through one division, the position of the rotary plates may be read directly to 1 part in 2500—equivalent to about 0.6 MMF. Since these sub-scale divisions are 1/16 of an inch apart, it is easy to estimate to one-fifth of a division. Mounted calibration curves are furnished for each coil. The standards used in calibrating are checked by means of a series of quartz plates. Harmonics of the plates were checked at low frequency against a standard clock.

The accuracy of calibration of the Type 224 Precision Wavemeter is to within 0.25%.

The condenser is mounted in a polished walnut case. Each inductance coil is enclosed in a walnut box with an engraved hard rubber panel stating the wavelength range. The terminal blocks are so shaped that they will fit on to the connecting bars in one way only, thus insuring that each coil will always be connected in the manner in which it was calibrated.

A strongly built whitewood shipping case is furnished with each wavemeter. Separate compartments are provided for the condenser and coils. This case is fitted with a carrying handle and lock.

Type 224 Precision Wavemeter 70—24,000 meters. \$190.00

Dimensions 18" x 11" x 11". Weight 27 lbs.

Code Word: WAGER.

GENERAL RADIO COMPANY

The Type 224-L Precision Wavemeter is similar in general construction to the Type 224 Precision Wavemeter, with such modifications as proved necessary for short-wave work.

Type 224-L Precision Wavemeter 15—600 meters.....\$200.00
Dimensions 18 $\frac{1}{4}$ " x 12 $\frac{1}{4}$ " x 13". Weight 23 $\frac{1}{2}$ lbs.
Code Word: UNDER.

TYPE 174 DIRECT-READING WAVEMETER



The Type 174 Direct-Reading Wavemeter is designed for general use in commercial and experimental radio stations. Its equipment is such that it is adapted for use with receiving or transmitting sets, employing either damped or undamped waves. Its self-contained, direct-reading features make this instrument particularly valuable for commercial work.

A hot-wire galvanometer is used for indicating resonance of transmitted signals of average intensity, while for weak signals a crystal detector and binding posts for telephones are provided. For producing damped oscillations of known wavelengths, the wavemeter is equipped

GENERAL RADIO COMPANY

with a high-frequency buzzer operating from a battery mounted within the wavemeter case. The oscillating circuit consists of three coils with a selector switch and a variable air condenser. The inductance coils are bank-wound in order to keep the distributed capacity at a minimum. The condenser is the low-loss Type 239 Variable Air Condenser, equipped with slow-motion gear.

Particular care has been given to the mechanical construction and to the appearance of this instrument. All of the equipment is mounted on a hard rubber panel and enclosed in a polished walnut carrying case fitted with lock and key. The metal parts are finished in polished nickel.

Two wavelength ranges are provided: the Type 174-C Direct-Reading Wavemeter covering amateur, broadcast and usual ship operation ranges; and the Type 174-D Direct-Reading Wavemeter covering broadcast, ship, and the special telephone ranges.

OPERATION. The dial, on which are drawn the three wavelength scales corresponding to the three inductance coils, is mounted directly above the variable condenser and is fastened to the rotor plate shaft. The scales are indicated by the numbers 1, 2 and 3 engraved on the panel. Above the galvanometer is a switch engraved **RANGE**, with points numbered 1, 2 and 3. These three points correspond respectively to the three wavelength scales. In addition to the three wavelength scales, a scale divided into one hundred equal divisions is provided. This scale is provided for reference and is convenient in making certain measurements.

TRANSMITTING SETS. In determining the wavelength of a transmitting set, the range switch should be set on the point covering the wavelength scale within which the transmitted wavelength should fall. The wavemeter should then be brought near the tuning inductance, the antenna or ground lead of the transmitter. By turning the knurled knob marked **INCREASE WAVELENGTH**, the variable condenser will be rotated, varying the wavelength of the wavemeter. At resonance—that is, the point where the wavelength of the wavemeter is the same as that of the transmitter—the maximum amount of energy will be transferred from the transmitting set to the wavemeter. This point is indicated by a maximum deflection of the hot-wire galvanometer. Care, however, should be taken that the wavemeter is not too near a powerful transmitter, because an excess amount of energy may be transferred to the wavemeter, causing the galvanometer to burn out. It will be found with a sharply tuned transmitter, particularly when using vacuum tubes, that the resonance point is very sharp. The condenser must be rotated slowly, as the galvanometer needle will swing from zero to nearly full scale and back again over a very small

GENERAL RADIO COMPANY

range of wavelengths. If the condenser is rotated too rapidly, the resonance point will be passed through without being noted. In the case of a buzzer or transmitter of small output, sufficient energy may not be radiated to operate the galvanometer. In this case, a pair of telephones should be connected to the binding posts marked TEL. Resonance will then be indicated by maximum intensity of signal in the telephones. This method is less accurate than that using the galvanometer as a resonance indicator, and should be avoided where possible.

RECEIVING SETS. Two methods of determining the wavelength of a receiving set may be employed. The first, the reaction method, is applicable only to a vacuum-tube receiving set, and then only when the set is oscillating. The wavemeter should be brought near the tuning inductance of the receiving set. By tuning the condenser of the wavemeter a sharp click will be heard in the headphones of the receiving set at the point where the condenser passes through the resonance point. The wavelength can then be read on the proper scale. It is usually necessary to have the wavemeter quite close to the receiving set. Since the axis of the coils in the wavemeter is parallel to the panel, and extends from front to rear of the case directly beneath the galvanometer, best results are usually obtained by placing the right-hand edge of the wavemeter parallel to the tuning coil of the receiving set.

GENERAL. Because of the sensitive type of buzzer used, it may be found that on turning the buzzer switch no sound can be heard. The buzzer-adjusting screw should be turned to the right or left until the buzzer starts to operate. If the buzzer will not operate, make certain that the battery is in good condition. When a wavemeter is shipped, no battery is placed in the wavemeter, but one is shipped separately. This method is used to prevent damage to the wavemeter in case it should remain unused for a long time. Dry cells kept for a long time in an inverted or horizontal position will deteriorate and leak; the wavemeter should, accordingly, always be stored so that the cover is on top, thus keeping the battery in an upright position.

The diagram mounted in the cover should be studied carefully in order to understand the wavemeter circuits. The four panel thumbscrews should be removed and the panel lifted from the case. The inside of the wavemeter should be examined in order to become familiar with its mechanical construction, but under no circumstances should adjustments be attempted, as they will affect the calibration. The buzzer battery should be put in place before replacing the panel. It will be noted that provision has been made on the panel for an external coil. This arrangement is to enable

GENERAL RADIO COMPANY

an additional coil to be used for special work. Under normal conditions the short-circuit bar between the two binding posts marked EXT. COIL should not be removed. This is true even when the telephone receivers are connected to the telephone binding posts. This bar is removed only when an external coil is used. Price includes battery.

Type 174-C Direct-Reading Wavemeter.....\$68.00

Range 75-1,500 meters.

Code Word: WEARY.

Type 174-D Direct-Reading Wavemeter.....\$68.00

Range 200-4,000 meters.

Code Word: WINDY.

Dimensions, both types, 9" x 7" x 6". Weight 9 $\frac{3}{8}$ lbs.

TYPE 532 STATION FREQUENCY METER

Where a transmitter, such as a broadcasting station, is operating on a fixed frequency, or over a narrow band of frequencies, a special type of meter may be used which possesses a high degree of accuracy over a narrow scale.

In the Type 532 Station Frequency Meter, advantage is taken of a somewhat unusual method of reading in order to get a close setting on the scale. The meter may be set to approximately 20 cycles at any point in the broadcast-frequency band. This does not imply that the absolute accuracy of the meter is 20 cycles.

A certificate of accuracy is furnished guaranteeing the accuracy of the scale division representing the station frequency to 500 cycles for a temperature variation of 5° Fahrenheit from the temperature specified on the certificate. The time limit on the guarantee is six months. At the end of this period the instrument should be returned to the factory for recalibration for which a fee of \$10.00 will be charged.

The Type 532 Station Frequency Meter consists of the usual resonant circuit type of wavemeter with some additional features. A large fixed condenser is shunted across the variable, so that the entire scale of the meter covers only 0.3% of the station frequency, with the station frequency in the center. There are ten scale divisions per kilocycle. In addition to the spread scale, another feature contributes to the accuracy of setting of the Type 532 Station Frequency Meter. A small auxiliary

GENERAL RADIO COMPANY

condenser may be connected across the main condenser by depressing a push button. The capacity of this condenser is sufficient to shift the resonant frequency of the meter from one side of the transmitter peak to the other. The frequency meter is adjusted until the galvanometer



reading is unchanged when the button is depressed. This method of locating the center or peak of the resonance curve is much more accurate than attempting to set to the top of the curve by observing maximum galvanometer deflection.

The Type 532 Station Frequency Meter supplements rather than displaces the piezo-electric oscillator. While the frequency meter permits a setting of the transmitter to within the Federal requirements, the stability of the meter is not as great as that of the piezo-electric oscillator, which should be maintained as a standard for checking the frequency meter. The

GENERAL RADIO COMPANY

piezo-electric oscillator, on the other hand, does not indicate how far off frequency the transmitter is, or in which direction, as the frequency meter does.

Type 532 Station Frequency Meter.....\$130.00

Dimensions $8\frac{1}{4}'' \times 8\frac{1}{2}'' \times 10\frac{3}{4}''$. Weight $14\frac{3}{4}$ lbs.

Code Word: SIREN.

— OO —

EXPERIMENTER'S WAVEMETERS

Supplementing the laboratory type wavemeters, the General Radio Company also manufactures a line of low-priced wavemeters for the transmitting amateur. Although low in price, these meters are so built as to maintain a calibration over considerable periods, and are accurately calibrated when leaving the factory, with the exception of the Type 247-W Wavemeter.

TYPE 358 WAVEMETER

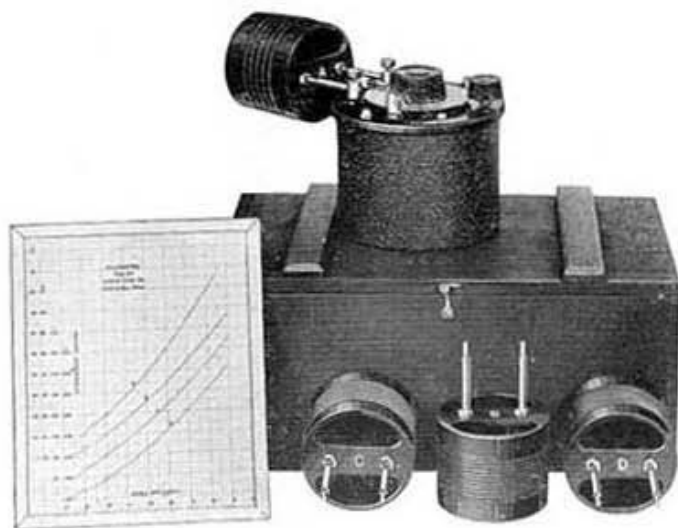

The General Radio Type 358 Wavemeter is designed particularly for experimenter use. It covers a wavelength range of approximately 14 to 220 meters, covering the short-wave bands in common use. The wavemeter consists of a mechanically rugged coil of low-loss construction, mounting directly on the binding posts of a shielded condenser. The condenser capacity is 125 MMF. Mounted on the condenser panel and connected in series between the condenser and coil is a resonance indicator in the form of a small lamp. The lamp socket is so arranged that it is short-circuited when the lamp is removed.

GENERAL RADIO COMPANY

The wavelength range is covered by means of four coils. Each wavemeter is individually calibrated with an accuracy of within 1%. A calibration curve is plotted for each coil and the curve sheet mounted on a substantial metal backing. The coil ranges, providing adequate overlaps, are as follows:

Coil A	14 to 28 Meters
Coil B	26 to 56 Meters
Coil C	54 to 114 Meters
Coil D	105 to 220 Meters

The condenser, coils and chart are contained in a wooden box, which provides proper protection for the instrument when not in use.

Type 358 Wavemeter complete \$15.00
Dimensions 11 $\frac{3}{4}$ " x 7 $\frac{1}{4}$ " x 5 $\frac{1}{2}$ ". Weight 4 $\frac{1}{2}$ lbs.
Code Word: UPPER.

TYPE 558 AMATEUR-BAND FREQUENCY METER

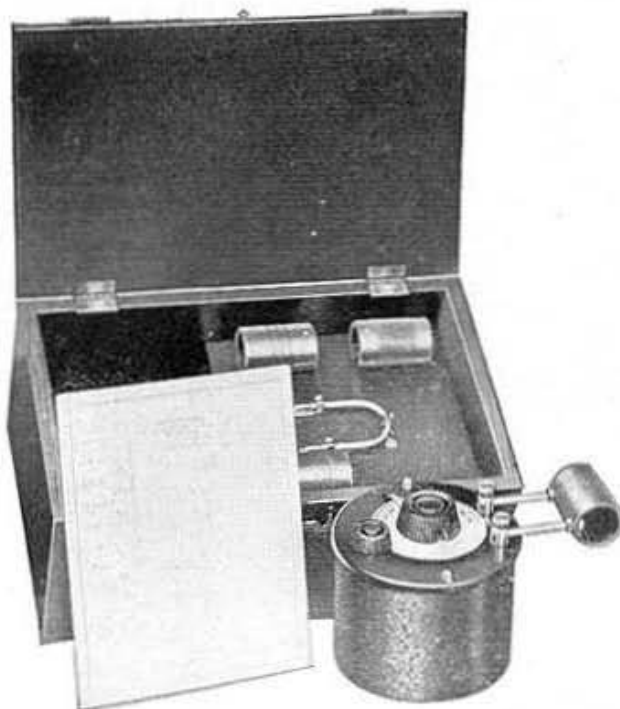

The increased congestion and decrease in width of the amateur bands make necessary the use of a more accurate frequency meter than has heretofore been available to amateurs at a low price. To meet this need the General Radio Company has developed a band-type frequency meter which employs a system used in broadcast station frequency meters in order to secure great precision over a limited band.

GENERAL RADIO COMPANY

In the Type 558 Amateur-Band Frequency Meter a fixed air condenser is connected in parallel with the variable condenser. This arrangement spreads a narrow band of frequencies over the entire frequency meter scale which greatly increases the accuracy of reading. Five coils are used, covering the following amateur bands:

Coil A	56,000 to 64,000 Kilocycles
Coil B	28,000 to 32,000 Kilocycles
Coil C	14,000 to 16,000 Kilocycles
Coil D	7,000 to 8,000 Kilocycles
Coil E	3,500 to 4,000 Kilocycles

A neon tube, mounted inside the condenser case and viewed through a hole in the panel, indicates resonance. The accuracy of calibration is to within 0.25%. When it is considered that this is the same precision as is guaranteed for the Type 224 Precision Wavemeter, the low price of this instrument is particularly striking.

A wooden case with a mounting rack for the coils and for the condenser is supplied with each frequency meter. A calibration chart is supplied with each instrument.

Type 558 Amateur-Band Frequency Meter.....\$20.00
Dimensions 11 $\frac{3}{4}$ " x 7 $\frac{1}{2}$ " x 5 $\frac{1}{2}$ ". Weight 4 $\frac{1}{2}$ lbs.
Code Word: UNION.

TYPE 458 5-METER WAVEMETER

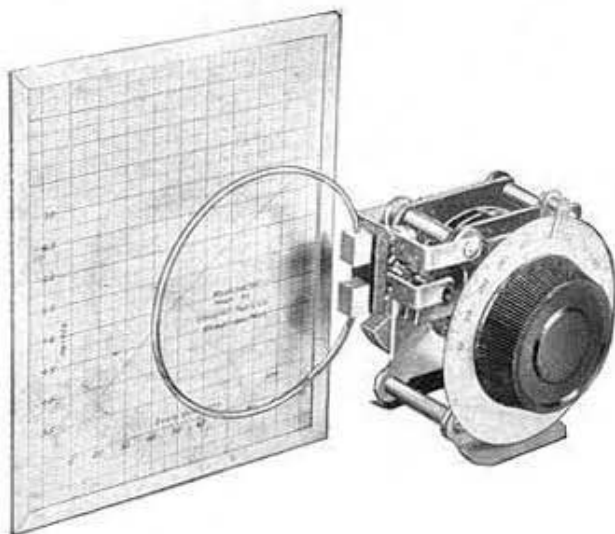

The recent developments in transmission at 5 meters (60,000 kilocycles) have made it desirable to have an accurate wavemeter covering that

GENERAL RADIO COMPANY

wavelength. The Type 458 5-Meter Wavemeter is supplied unmounted, having only brackets to support the condenser in an upright position. The condenser is of the usual soldered plate, metal end-plate type, having a maximum capacitance of 50 MMF. The importance of soldered plates at this high frequency can hardly be over-emphasized. The coil consists of a single turn of $\frac{1}{8}$ " copper tubing, and is connected to the condenser by means of the convenient General Radio plugs. The coil is silver plated. A 4" dial and indicator completes the wavemeter. It is found that the metal end plates so completely shield the condenser that hand capacity is not troublesome. Like other General Radio wavemeters, each has its individual calibration chart and is calibrated against a precision standard.

Type 458 5-Meter Wavemeter \$8.00
 Dimensions 9" x 5 $\frac{1}{2}$ " x 3 $\frac{3}{4}$ ". Weight 1 $\frac{1}{2}$ lbs.
 Code Word: UMBER.

TYPE 247-W WAVEMETER AND FILTER

The range of the Type 247-W Wavemeter and Filter is 200 to 600 meters. Wavelengths are determined by direct readings from the condenser dial, which is calibrated with an accuracy of within 2%.



The filter coil may be connected either in series or parallel with the receiving set. When used in the series connection a single interfering broadcasting station may be eliminated. The parallel filter is used to eliminate several interfering stations simultaneously and accept only one station within the filter range.

A full set of instructions accompanies each instrument.

Type	Description	Dimensions	Weight	Code Word	Price
247-W	Wavemeter and Filter	6" x 4 $\frac{1}{2}$ " x 8"	2 $\frac{1}{2}$ lbs.	WAGON	\$7.00
247-W2	Extension Coil (400-1200 meters)	4" x 4" x 3"	6 oz.	VOCAL	2.75
247-W $\frac{1}{2}$	Extension Coil (100-300 meters)	4" x 4" x 3"	6 oz.	VIZOR	2.75
247-W $\frac{1}{4}$	Extension Coil (50-150 meters)	4" x 4" x 3"	6 oz.	VIVID	2.75

OSCILLATORS

Oscillators are required in the communication laboratory for bridge and other measurements at fixed frequency and for observation of characteristics and behavior of apparatus over a range of frequencies. For fixed frequencies and for bridge measurements, a simple form of tuning-fork microphone hummer is satisfactory. Variable-frequency oscillators are generally of the vacuum-tube type. A number of such oscillators for specific purposes and ranges are described in the following section. Fixed frequency oscillators for frequency standards are listed in the section on frequency standards.

TYPE 213 AUDIO OSCILLATOR



A multitude of bridge measurements require a dependable source of alternating current of low power. The frequency must remain constant. The supply source should also be simple in its operation, rugged and reliable. It was to meet these requirements that the Type 213 Audio Oscillator was designed.

The output of this oscillator is about 0.06 watt at 1000 cycles. External binding posts are so arranged that three output voltages may be obtained. The outputs obtainable with these three different connections are as follows:

GENERAL RADIO COMPANY

Point	Voltage	Current
Low	0.5 Volt	100 Milliamperes
Medium	1.5 Volts	40 Milliamperes
High	5.0 Volts	12 Milliamperes

For some capacitance measurements it is desirable to use a high voltage. This increased voltage may be obtained by connecting an inductance and capacitance in series across the high-voltage output terminals of the oscillator. By adjusting this circuit to resonance, voltages as high as 50 or 100 may be obtained by connecting output leads across the condenser. This instrument will operate satisfactorily on from 4 to 8 volts. The input current is approximately 0.13 ampere. When running, the oscillator may be heard for a distance of approximately twenty-five feet, or may be made silent by enclosing in a sound-proof box. When the oscillator is used in close proximity to the bridge or to other apparatus it will be found advisable to shield the oscillator to prevent pick-up in other circuits.

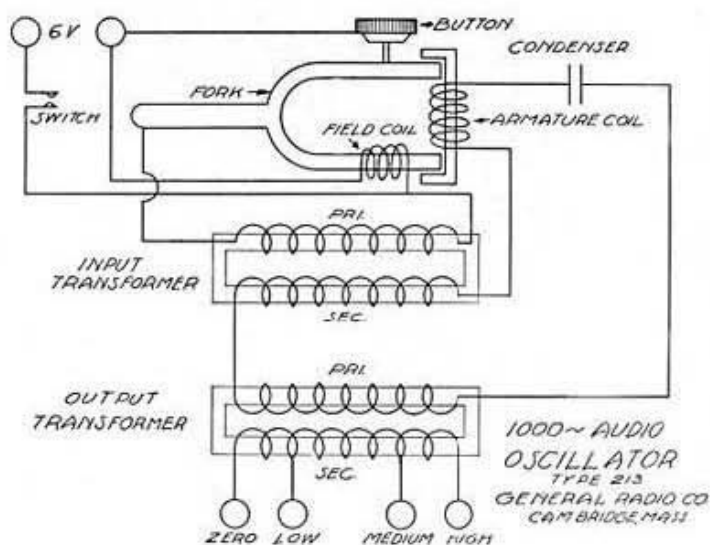

The circuits of this oscillator are shown in the diagram. The closing of the switch places the field-magnetizing coil directly across the battery. Also across the battery is the primary of the input transformer in series with the microphone button. The resonant circuit consists of the secondary of the input transformer, the primary of the output transformer, the armature coil and the condenser. The output-transformer secondary has three taps to permit the obtaining of three different output voltages.

GENERAL RADIO COMPANY

Each transformer core has a small air gap to prevent distortion of the wave-form. Since the oscillator is self-starting, it may be located at a point distant from the bridge and operated by a switch placed at the bridge. The tuning fork maintains the frequency within the narrow limits determined by temperature variations. Due to the loading of the fork the mean frequency is about 990 cycles rather than 1000 cycles.

By using the field-magnetizing coil on one tine of the vibrating fork, instead of relying on its permanent magnetism, the polarity and intensity of the magnetization of the fork with respect to the armature are permanently maintained.

Success or failure in the operation of a hummer, or audio oscillator, lies very largely in the microphone button. If the button heats so that the oscillator cannot be run indefinitely, if the adjustment of the button is not permanent, or if slight mechanical shocks change its operating characteristics, the oscillator has little commercial value. A distortion of as small an amount as one five-hundredth of an inch from normal position of the mica will destroy the perfect operation of the button. In order that the button may be insensitive to mechanical shocks and yet operate properly at 1000 cycles, use is made of its high inertia effect at the latter frequency. One side of the button is attached to the tuning fork by means of a short, flat spring. The other side, which has a projecting mounting post, is held in position by a specially designed self-centering spring. This combination of springs enables the button to withstand severe shocks, yet it has sufficient inertia so that perfect operation is obtained. The adjustment of the button is permanent and needs no further attention after leaving our laboratory. This type of mounting, together with the fact that the electrical constants of the circuits have been adjusted to their optimum values, insures the continuous operation of the oscillator without heating.

It should, of course, be understood that this oscillator is not intended to displace the larger types of oscillators used where several watts of output are required. It is intended rather for general laboratory use where power of good wave-form is desired for a single bridge. Since the purity of wave-form is dependent on the load on the oscillator, whenever a pure wave-form is essential the oscillator should not be overloaded. This oscillator is adapted for the usual alternating-current measurements of inductance and capacitance.

The oscillator is mounted in a polished walnut box with bakelite panel. The exposed metal parts are nickel plated. The control switch is easily accessible and is of the convenient lock-button design.

GENERAL RADIO COMPANY

Type 213 Audio Oscillator \$32.00
Dimensions 6" x 4 $\frac{3}{4}$ " x 5". Weight 4 $\frac{1}{2}$ lbs.
Code Word: AUGER.

TYPE 377 LOW-FREQUENCY OSCILLATOR

Many forms of electrical and physical research problems require a source of alternating current of good wave-form, variable over a wide range of frequencies. The properties of the oscillating vacuum tube make it inherently adapted for use as such a source.

By means of a licensing agreement with the Radio Corporation of America, the General Radio Company is able to supply such an oscillator for laboratory use.

The Type 377 Low-Frequency Oscillator has a frequency range of from 65 cycles to 75,000 cycles, extending through the audio and carrier frequency ranges into the lower radio frequencies. The simplified circuit of the oscillator is shown in Fig. 1. The frequency of the oscillating tube (left) is controlled by tuning the plate circuit. The output of the



oscillating tube is fed through a coupling potentiometer to the amplifier tube (right). The plate of the amplifier tube is connected direct to the output terminals. The parallel-feed system of plate supply is used on both tubes.

The front panel assembly of the oscillator is shown above. The meters are so equipped with switching arrangements that filament or plate voltage and oscillator or amplifier plate current may be read.

GENERAL RADIO COMPANY

The two switches directly under the meters are the transfer switches. A grid-current meter is mounted above the filament and plate meters to indicate overload.

The output of the oscillator is adjustable and may be held constant over the frequency range by means of the potentiometer coupling to the amplifier tube. The resistance marked FEEDBACK is in the plate of the oscillator tube, and controls oscillation. For most satisfactory wave-form the feedback control should be set at the point at which the tube just begins to oscillate.

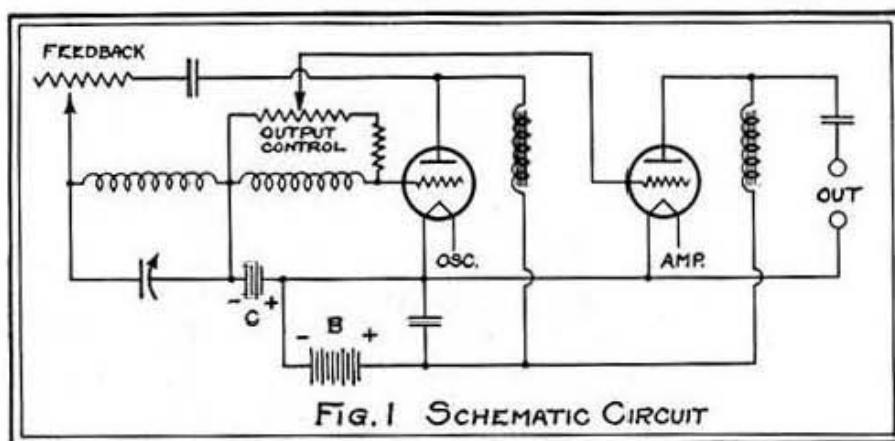

The frequency is continuously variable by means of the seven controls on the lower part of the panel. There are three coils, so tapped as to give six switch positions, and a decade capacity system extending from 0.001 MF. to 1.0 MF. An air condenser with maximum of 0.0011 MF. makes the capacity system continuously variable.

An approximate calibration, good to within 5%, giving the settings of the controls at frequency intervals of about 10% for the entire frequency range, is provided with each instrument. This calibration is accurate only when the instrument does not take excessive grid current. The oscillator should be adjusted so as to keep the reading of the grid-current meter as low as possible, and in no case should it exceed one-half milliamper.

The oscillator is intended to be used with either UX-201A, UX-112A or UX-210 tubes. For average use the UX-112A type will be found satisfactory.

The wave-form of the oscillator output is very nearly sinusoidal, provided the tube is not overloaded, as indicated by the grid-current meter. The largest single harmonic component in the voltage wave is of the

GENERAL RADIO COMPANY

order of 2%. Where particularly good wave-form is required, it is advisable to use tubes of the UX-210 type. Load does not affect wave-form unless the amplifier tube is overloaded. The load will not affect the frequency, since it is not applied directly to the oscillating tube. Frequency does not vary more than 1% with ordinary variations in tube conditions.

The power output of the instrument will vary with the plate voltage and the type of tube. With a UX-210 tube, the output is about 0.2 watt with 120 volts on the plate and about 0.5 watt with 220 volts on the plate.

The entire oscillator is mounted in a sturdy oak cabinet with substantial brass carrying handles and clasp. The panel swings outward, giving easy access to the instruments, all of which are mounted on the back of the panel.

Battery and output connections are carried through holes in the cabinet and made to the back of the panel. The cabinet is strong



enough so that the oscillator may be hung from a wall by means of bolts through the back of the cabinet.

Space sufficient for five blocks of plate batteries of the $3\frac{1}{4}'' \times 2\frac{3}{4}'' \times 5\frac{5}{8}''$ size is provided in the cabinet, thus providing 112.5 volts.

USES. The low-frequency oscillator will be found of great use in all measurement work at audio, carrier and low radio frequencies. Among its uses are bridge measurements of all kinds, studies of the response curves of transformers and loudspeakers, the study of filter characteristics, and the study of cable and other dielectric behavior. Price does not include tubes or batteries.

GENERAL RADIO COMPANY

Licensed under Patent No. 1,113,149 for radio laboratory experimental use only where no business features are involved.

Type 377 Low-Frequency Oscillator.....\$350.00

Dimensions $19\frac{1}{8}$ " x 18" x $10\frac{1}{2}$ ". Weight 57 lbs.

Code Word: OMEGA.

TYPE 413 BEAT-FREQUENCY OSCILLATOR

In measuring loud-speakers and audio-frequency systems, it is often desirable to move through the entire frequency range quickly. The conventional type of vacuum-tube oscillator, although it may be so designed as to be continuously variable, requires the adjustment of a number of controls in varying the frequency through the entire audio range. Since the change in frequency involved is large, about five hundred to one, it cannot be obtained by the rotation of a single instrument of prac-



ticable construction. If, however, the measuring frequency is obtained by beating two oscillators together, a small percentage change in frequency of one of the oscillators will cause a relatively large change in the beat frequency.

Supplementing its oscillators of conventional type, the General Radio Company is manufacturing a beat-frequency oscillator with a range of approximately 20 to 9000 cycles. The Type 413 Beat-Frequency Oscillator consists of two oscillator tubes, a detector, and an amplifier tube. The frequency of one of the oscillators is fixed at about 60 kilocycles, while that of the other is variable from approximately 50 kilocycles to 60 kilocycles. Both oscillators are coupled to the grid circuit of the detector tube. The oscillators are so constructed and shielded as to maintain a constant frequency over long periods without adjustment. The system of coupling the oscillators to the detector, supplying it with a low voltage from each oscillator, is such that tendency of the two oscillators to pull into synchronism as zero beat is approached is eliminated.

GENERAL RADIO COMPANY

The detector output is fed to an amplifier through a Type 373 Double-Impedance Coupler, giving nearly constant amplification over the wide range of frequencies used. The output of the oscillator is taken off across a 10,000-ohm resistor, used as a voltage divider, permitting the adjustment of the output voltage without changes in the oscillator circuit proper that might affect wave-form or frequency.

Three variable capacities will be seen in the following diagram. One of these is a small compensating condenser mounted inside the instrument. The purpose of this condenser is to correct any slight inaccuracy in the fixed condenser in this circuit. Slight changes in frequency of either oscillator due to changes in circuit conditions may be compensated for by means of this condenser, which is adjusted so as to bring the two oscillators to zero beat. The frequency is changed by means of two other variable condensers, the main tuning unit of 500 MMF. maximum capacity, and a micro-condenser shunted across it for fine adjustment.

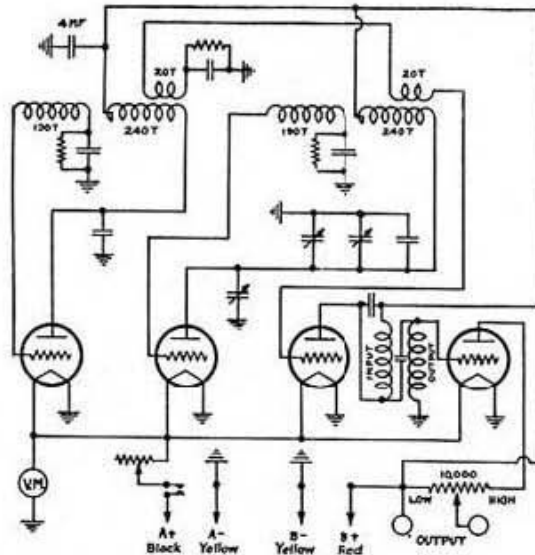

The Type 413 Beat-Frequency Oscillator is designed for use with either WX-12 or UX-199 tubes, space being provided in the cabinet for three 1.5-volt dry cells and three 22.5-volt plate batteries. UX-201A tubes may be used with an external battery if desired. A 5-volt Weston meter on the panel and a rheostat inside the cabinet permit the adjustment of the filament voltage to the rated value. The Type 413 Beat-Frequency Oscillator has an output of about 1.5 volts. The wave-form is satisfactory for most purposes, the total of the voltage harmonics being at a maximum but 4% of the wave.

The Type 413 Beat-Frequency Oscillator is useful in the measurement of all devices intended for operation in the audio-frequency range.

GENERAL RADIO COMPANY

It is particularly helpful in the study of loud-speaker response curves, since the complete frequency range is available by one-half revolution of the main dial. Peaks or hollows in the loud-speaker response are immediately evident, and any tendency to blast at particular frequencies is quickly revealed.

The Type 413 Beat-Frequency Oscillator may also be used to modulate the output of the Type 384 Radio-Frequency Oscillator. The modulated radio-frequency output thus obtained may be used in testing receiving sets for both radio and audio-frequency response. The audio modulating frequency can be compared quickly with that of the audio-frequency output of the receiver by using an oscillograph such as the Type 338 String Oscillograph.

This instrument is licensed under Patent No. 1,113,149 by the Radio Corporation of America and associated companies for experimental laboratory use only where no commercial features are involved. Price does not include batteries or tubes.

Type 413 Beat-Frequency Oscillator.....\$210.00

Dimensions 12" x 8" x 20". Weight, 25½ lbs.

Code Word: ORGAN.

TYPE 384 RADIO-FREQUENCY OSCILLATOR



A small radio-frequency oscillator has a wide range of usefulness in the laboratory. For maximum utility such an instrument must have a wide frequency range and be readily portable. The Type 384 Radio-Frequency Oscillator has been designed to meet these requirements.

GENERAL RADIO COMPANY

This oscillator is of the plug-in coil type. The range may be extended from 15 to 30,000 meters by means of nine coils. A single UX-199 tube is used, which permits an entirely self-contained instrument. A plate milliammeter is provided to indicate oscillation.

The Type 384 Radio-Frequency Oscillator may be used as a power source in high-frequency measurements of coils and condensers. Input terminals are provided so that a beat-frequency oscillator may be used as a modulator.

The Type 384 Radio-Frequency Oscillator is also readily adapted for use as the auxiliary oscillator required in conjunction with the Type 275 Piezo-Electric Oscillator when using harmonics of the plate frequency for the calibration of frequency standards. Price does not include tubes or batteries.

Type 384 Radio-Frequency Oscillator, without coils.....\$90.00

Dimensions 18" x 9 $\frac{1}{8}$ " x 9 $\frac{1}{8}$ ". Weight 13 lbs.

Code Word: ODIUM.

The following coils are available for use with the Type 384 Radio-Frequency Oscillator:

<i>Type</i>	<i>Range</i>		<i>Code Word</i>	<i>Price</i>
384-A	15-30	Meters	HAZEL	\$3.00
384-B	30-80	Meters	HEAVY	3.00
384-C	70-200	Meters	HELOT	3.00
384-D	190-575	Meters	HERON	3.00
384-E	565-1,700	Meters	HILLY	4.00
384-F	1,700-4,400	Meters	HINNY	4.00
384-G	4,400-12,000	Meters	HOARY	5.00
384-H	12,000-30,000	Meters	HOLLY	8.50
384-D 8	200-600	Meters	HOBBY	4.50

The D8 Coil is a figure-8 coil, designed to have minimum external field.

TYPE 403 STANDARD-SIGNAL GENERATOR



A generator of known radio-frequency voltage has a number of applications in the testing of receivers and in the measurement of field strength by comparison methods. The generator should be variable in voltage over a wide range, and so thoroughly shielded that no external field is set up. The Type 403 Standard-Signal Generator has a range of 1 to 200,000 microvolts, which is sufficient for measurement of the most sensitive type of receiver now available.

The Type 403 Standard-Signal Generator consists of a radio-frequency oscillator with fixed frequency modulation by means of a self-contained audio oscillator, and a calibrated attenuator.

In addition to the tests of receiver-gain measurements, the signal generator may be used for field-strength measurement by comparison methods, for gain measurements on radio-frequency amplifiers, or for measurement of detector characteristics and of the combined characteristics of detector and audio amplifier.

The Type 403 Standard-Signal Generator is designed for use with external unshielded batteries, and external modulation where variable frequency modulation is desired for fidelity tests. To this end the leads to the battery terminals and to the external modulation terminals are equipped with filters which confine the radio frequency entirely within the instrument. The leads to the meters on the panel are also filtered, eliminating

GENERAL RADIO COMPANY

the necessity for screening the fronts of meters. The oscillator covers a frequency range of 500 to 1500 kilocycles. The radio-frequency output is passed through an attenuator to the output terminals at the upper right (see photograph). The attenuator is controlled by two knobs. The first of these, controlling the multiplier, changes the output in decade steps for a given radio-frequency current. The second knob, controlling the output scale, provides a continuous variation of the output voltage, proportional to the scale divisions at any value of radio-frequency current for any given point of the multiplier scale. The radio-frequency current input to the attenuator is indicated by a thermal instrument, the direct-current galvanometer of which is mounted on the front panel and marked RADIO CURRENT. A current calibration is provided for this instrument. The oscillator and attenuator are thoroughly shielded. The maximum error of voltage ratio in the attenuator is 4%.

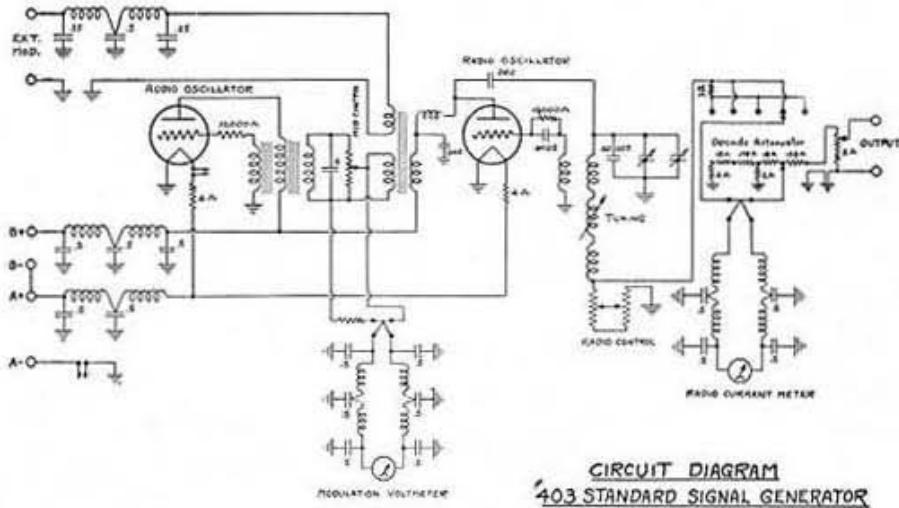

The signal generator is provided with an internal audio oscillator which modulates the radio-frequency signal at 400 cycles. The modulating voltage is impressed across a transformer winding in series with the total plate battery and the plate circuit of the radio-frequency oscillator. The root-mean-square value of this voltage is indicated by a thermal voltmeter, the direct-current galvanometer of which, calibrated in root-mean-square volts, is mounted in the front panel. This voltmeter indicates the audio-frequency voltage impressed on the oscillator with either internal or external modulation, which may be varied by means of the knob marked MODULATION.

The Type 403 Standard-Signal Generator is applied to the measurement of over-all characteristics of radio receivers in accordance with the

GENERAL RADIO COMPANY

conventional assumption that the effects of a wave field upon an exposed antenna or loop of known constants may be simulated in all respects by the introduction into the receiver of a known locally-generated radio voltage, through a local ("dummy") antenna or coil aerial having the same constants at the operating frequency. This signal generator is particularly adapted for use with antenna-operated receivers, in which the factor for conversion of the local signal in microvolts to an equivalent field strength is simply a length or "effective height." However, by use of a suitable coil-conversion factor, the generator may be used to measure sets operated with a coil aerial. For the conventional measurements of sensitivity, selectivity and fidelity, two pieces of equipment are required in addition to the signal generator: (1) local aerial circuit; (2) receiver-output meter, comprising a resistance load of a magnitude appropriate to the output tube of the receiver under test, together with a thermal meter for measuring the audio current in the load, or a vacuum-tube voltmeter for measuring the voltage across the load. Both of these instruments can be easily assembled from standard laboratory equipment. It is recommended that the results of receiver measurements all be expressed in terms of microvolts input to the local antenna circuit to yield "Normal Signal" output from the receiver at different audio and radio frequencies, on and off resonance. The conventional value for "Normal Signal" is 50 milliwatts in a load of from 2000 to 6000 ohms. The revised "Report of Subcommittee on Receiving Sets" of the Institute of Radio Engineers, a copy of which may be obtained from the Secretary of the Institute, contains details of a suitable technique for making these measurements by means of a signal generator.

The entire instrument is thoroughly shielded, and external leads are fitted with filters. The shielding is sufficiently complete so that the Type 403 Standard-Signal Generator may be used for tests of unshielded receivers.

A complete set of operating instructions accompanies the generator.

Licensed under Patent No. 1,113,149 for laboratory use only where no business features are involved.

Type 403 Standard-Signal Generator.....\$600.00

Dimensions 18½" x 12½" x 8". Weight 40 lbs.

Code Word: SCALY.

METERS

A specialized type of meter is required for use in the communications laboratory. Such meters must operate without great error over wide frequency ranges. Certain requirements demand a voltmeter with an infinite input resistance.

TYPE 426-A THERMIONIC VOLTMETER



The vacuum tube lends itself particularly well for use as a voltmeter where no current may be taken by the instrument. This is because the grid-filament impedance of a tube is practically infinite until very high frequencies are reached, as long as the grid is maintained negative. A number of voltmeters have been developed making use of the vacuum tube, but few are commercially available.

The Type 426-A Thermionic Voltmeter possesses several features not usual in such instruments. All external circuits have been eliminated. The single battery required is contained in a compartment with the instrument case. The only zero adjustment required is made with a rheostat mounted in the case. This single rheostat adjustment controls the filament current, grid bias and plate voltage simultaneously, and is made by setting the meter pointer to zero. The instrument is then direct reading. The voltmeter terminals must be closed through a direct-current path, such as a measuring coil or a grid leak, when this setting is made.

In the Type 426-A Thermionic Voltmeter, the plate-filament resistance of a three-element tube is used as one arm of the bridge circuit shown

GENERAL RADIO COMPANY

below. The value of this resistance is greatly changed as a result of changes in the grid potential caused by the measured voltage, which is impressed between grid and filament. The current flow through the microammeter, which results from the unbalance of the bridge, is a measure of the voltage impressed. A single battery supplies all voltage requirements

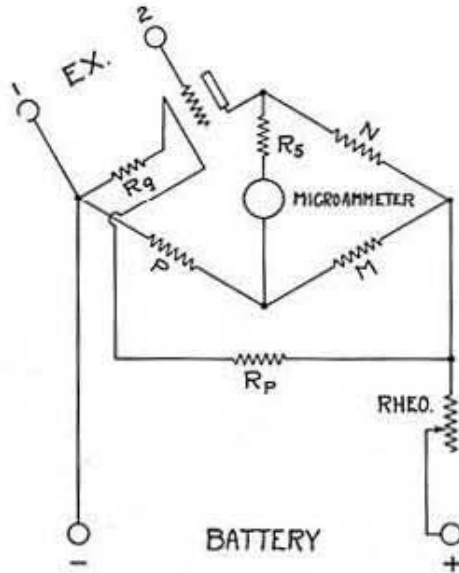

of the vacuum tube, suitable resistors dividing the total voltage drop between grid, filament and plate. It will be observed that the plate voltage is impressed across the bridge and corresponds to the exciting voltage of the usual Wheatstone bridge. All the resistances except the rheostat are permanently adjusted at the time the meter is calibrated. The resistances are so related that the tube is worked near the lower bend of the grid-voltage-plate-current characteristic.

When an alternating voltage is impressed across the terminals of the meter, the negative loops are suppressed, the meter giving an indication proportional to a value between the average and effective values of the wave. The calibration is made against root-mean-square values of a sinusoidal wave.

The Type 426-A Thermionic Voltmeter uses a tube of low filament consumption and requires only 22.5 volts. Space is provided in the instrument case to accommodate two 22.5-volt batteries connected in parallel. Provision is also made for connecting an external battery.

Under usual conditions the calibration will be maintained to within 0.5% up to about 1000 hours, at which time the instrument should be re-

GENERAL RADIO COMPANY

turned to the factory for a new tube and recalibration. The wave-form error is slight. A 20% third harmonic in the wave produces an error of but 0.4% in the meter reading. The meter is extremely resistant to over-voltage. 50 volts may be momentarily impressed on the 3-volt meter without damage.

The voltage calibration is reliable over the entire audio-frequency range. The frequency error is less than 2% of full scale at 20 kilocycles and less than 3% at 300 kilocycles. The calibration is not reliable at broadcast and higher radio frequencies although the meter is useful at such frequencies as a resonance indicator or for voltage comparisons.

The meter is contained in a walnut case with battery compartment. The tube is soldered in place, and attempts to remove it will break these connections. The price includes tube but not the battery.

Type 426-A Thermionic Voltmeter, Range 0-3 volts.....\$160.00

Dimensions 9" x 7 $\frac{1}{4}$ " x 10 $\frac{1}{4}$ ". Weight 11 lbs.

Code Word: SERUM.

TYPE 189 POINTER GALVANOMETER



Most laboratories require a rugged, sensitive, portable instrument for the measurement of currents of the order of 10 to 1000 microamperes. The Type 189 Pointer Galvanometer is adapted for just such service.

This instrument is of the D'Arsonval type, using the strained suspension, which permits of greater sensitivity than the pivot type and

GENERAL RADIO COMPANY

requires no leveling. The coil is wound on a damping form and adjusted to bring the coil under critical damping. The construction is such as to allow a safe clearance between the coil and the shoes of the magnet poles, thus preventing interference from chance lint or dust particles.

The suspension is of phosphor bronze rolled into a thin strip. The spring support for the suspension is such as to take up all ordinary shocks without danger of straining or snapping the suspension. This type of construction, together with the natural properties of the phosphor bronze strip, insure a reasonably stable zero. The galvanometer pointer is fitted with a zero adjustment, and a clamp.

Its combination of portability and sensitivity make this instrument available for a wide variety of uses, ranging from indicating a bridge balance to the measurement of radio signal strength when used with a suitable rectifier. The clearly drawn three-inch scale makes the reading of the instrument very easy.

The case is of polished walnut and the metal parts are nickel plated. A convenient leather carrying strap is provided.

Type	Zero	Approximate Resistance	Approximate Microamperes full scale	Code Word
189-E	Left	10 Ohms	150	GABLE
189-F	Centre	10 Ohms	75	GAILY
189-H	Left	100 Ohms	50	GALOP
189-J	Centre	100 Ohms	25	GAMIN
189-L	Left	2000 Ohms	10	GAZEL

Type 189 Pointer Galvanometer \$36.00

Size 5" x 5" x 3½". Weight 2½ lbs.

TYPE 127 AND TYPE 170 HOT-WIRE METERS

An instrument for the measurement of currents at high frequencies must have its inductance and capacitance kept as small as possible. High impedance would cause the readings to vary with frequency. For many radio-frequency measurements a suitably designed hot-wire ammeter has the necessary characteristics which particularly adapt it to this work. It should, however, be recognized that a hot-wire ammeter is inherently less accurate than an ammeter of the moving-coil type, which, of course, is unsuitable for measuring current at high frequencies. In the Types 127 and 170 Hot-Wire Meters careful design and good workmanship have produced instruments which are electrically and mechanic-



GENERAL RADIO COMPANY

ally good, rugged and reliable. These meters, particularly the galvanometer type, which has a 270-milliamperere range (uncalibrated), are used very extensively in wavemeters and similar oscillatory circuits for determining the resonance point. The Type 127 Hot-Wire Meters are used extensively

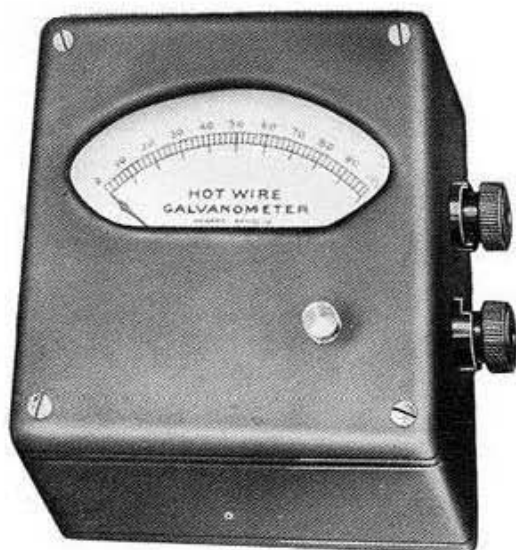

Type 170 Hot-Wire Meter

for measuring the radiation, filament and plate currents in experimental continuous-wave transmitting stations. The Type 170 Hot-Wire Meters have found a wide use outside of the radio field. They are used as transfer instruments in generator testing and similar work.

The expanding strip in these meters is of thin platinum, in order to prevent oxidation. It is so proportioned that it works at a low temperature and is of low resistance. These are two highly desirable features, since the former permits reasonable overloading without burning out, and the latter minimizes the losses.

The type of multiplying action is such that a more uniform scale is obtained than with many hot-wire meters. These meters have been corrected for temperature so that there is very little shift of zero. Any necessary correction may be made by adjusting a knurled screw. This type of instrument is equally accurate on direct or alternating current of any frequency.

These instruments are made in two general sizes. The Type 127

GENERAL RADIO COMPANY

Hot-Wire Meter is the smaller, or three-inch size, and is made in three types, portable, front-of-board mounting and flush mounting. The Type 170 Hot-Wire Meter is the large size and is made only in the portable type. It is mounted in a polished walnut case and fitted with a carrying strap.

The Type 170 Meters are made in the sizes listed below.

Range	Resistance	Code Word	Price
100 Milliamperes	31.0 Ohms	EXULT	\$20.00
250 Milliamperes	6.8 Ohms	EVOKE	20.00
500 Milliamperes	3.4 Ohms	EXACT	20.00
1 Ampere	1.2 Ohms	EXCEL	20.00
2 Amperes	0.55 Ohms	EXERT	20.00
3 Amperes	0.3 Ohms	EXILE	20.00
5 Amperes	0.16 Ohms	EXIST	20.00
10 Amperes	0.08 Ohms	EXPEL	20.00
20 Amperes	0.04 Ohms	EXTRA	20.00
Galvanometer	4.4 Ohms	ETHER	20.00

Dimensions $4\frac{3}{4}'' \times 5'' \times 3\frac{1}{2}''$. Weight 16 oz.



TYPE 127-A



TYPE 127-B



TYPE 127-C

The case of the Type 127-A Meter is die-cast with black japan finish. The cases of the Types 127-B and 127-C Meters are of moulded bakelite.

Range	Type 127-A	Type 127-B	Price	Type 127-C	Price
	Flush Mounting	Front-of-Board		Portable	
	Code Word	Code Word	Either Type	Code Word	
100 Milliamperes	MEDAL	MAYOR	\$6.00	MUGGY	\$6.50
250 Milliamperes	MERCY	MADAM	6.00	MOCHA	6.50
500 Milliamperes	MERIT	MAJOR	6.00	MOGUL	6.50
1 Ampere	MERRY	MANOR	6.00	MOLAR	6.50
1.5 Amperes	MINUS	MISTY	6.00	—	—
2.5 Amperes	MINOR	MAPLE	6.00	MOTOR	6.50
5 Amperes	MINIM	MATIN	6.00	MUMMY	6.50
10 Amperes	MINNY	MAXIM	6.00	MUSTY	6.50
Galvanometer	MITER	MAGIC	5.75	MOTTO	6.25

Types 127-A and 127-B Dimensions $3'' \times 3'' \times 1\frac{1}{2}''$. Weight $9\frac{1}{2}$ oz.

Type 127-C Dimensions $3'' \times 3\frac{3}{4}'' \times 1\frac{1}{2}''$. Weight 8 oz.

GENERAL RADIO COMPANY

TYPE 287 DIRECT-READING OHMMETER



There are many occasions in laboratories, service stations, and factories where an approximate measurement of resistance is required. The Type 287 Direct-Reading Ohmmeter is designed for the quick determination of resistance where an approximate value is sufficient.

The Type 287 Direct-Reading Ohmmeter consists of a battery and meter in series with a resistance, which protects the meter from damage at short circuit, and a rheostat shunted across the meter to provide a zero adjustment. The dial is calibrated directly in ohms. Clip leads are provided for convenience in connecting the instrument to the device to be measured.

One of the greatest uses of this ohmmeter is for the checking of apparatus and tracing of circuits. Its indication of the actual resistance of the circuit makes the ohmmeter useful when the battery and telephone method of tracing circuits is of little use. This feature makes it possible to detect not only open and short circuits, but also wrong connections.

Before using the ohmmeter, the zero should be checked by connecting the terminals together. The knob should then be adjusted until the meter needle registers zero resistance (short circuit). The short-circuiting connection is then removed and the meter is ready for use. If the meter is to be shipped or stored for a considerable length of time the battery should be removed to prevent possible spilling with resultant injury to the cabinet. Price includes battery.

Type 287-A Direct-Reading Ohmmeter. Range 0 to 10,000 ohms. . . \$30.00
Code Word: ONION.

Type 287-B Direct-Reading Ohmmeter. Range 0 to 2000 ohms. . . . \$30.00
Code Word: ORBIT.

Dimensions $6\frac{3}{4}$ " x $5\frac{3}{4}$ " x $4\frac{1}{2}$ ". Weight $2\frac{1}{2}$ lbs.

[101]

GENERAL RADIO COMPANY

TYPE 330 FILTER SECTIONS



Electrical filters are used extensively in studying the characteristics of communication equipment and in the transmission of electrical impulses of multiple frequency, such as speech or music. Such filters consist of capacitance and inductance networks so designed that they allow certain frequencies to pass through them readily while at the same time other frequencies are highly attenuated. By the use of filters, for instance, a composite sound may be divided into several parts or a fault in telephone apparatus may be remedied by attenuating or placing emphasis on certain ranges of the frequency spectrum.

Filters may be divided into four general classes as follows:

(1) Low-pass filters, which cut off all frequencies above a definite predetermined value.

(2) High-pass filters, which cut off all frequencies below a predetermined value.

(3) Band-elimination filters, which cut out all frequencies between two predetermined values.

(4) Band-pass filters, which cut out all frequencies below the lower and above the upper of two predetermined values.

These four classes of filters can be formed in a variety of networks, some simple and others more complicated in their structure. For a theoretical discussion of such filter networks the reader is referred to two texts, namely, "Transmission Circuits for Telephone Communication" by K. S. Johnson, and "Electric Oscillations and Electric Waves" by G. W. Pierce.

GENERAL RADIO COMPANY

An electrical filter may consist of a single network or section, or it may be rendered more effective by containing several recurrent sections joined in series.

As an aid to the experimenter who desires to study the characteristics of such filters or to use them in communication circuits, the General Radio Company has developed a series of simple high-pass and low-pass filter sections mounted in individual cases. The high-pass filters take the form known as a T-type section, while the low-pass filters are constructed in the form of a π section.

In order to determine the electrical constants of the elements of such a filter it is necessary to know two things: first, the desired cut-off frequency F ; and second, what is known as the iterative impedance Z of the circuit in which the filter is to be placed. The values of capacitance and inductance for the high-pass filter section may then be computed from the equations:

$$C_1 = \frac{0.07958}{FZ} \text{ Farads}$$

$$L_2 = \frac{0.07958Z}{F} \text{ Henrys}$$

where F is the frequency in cycles per second, and Z the iterative impedance in ohms.

For the low-pass filter we have, in a similar manner:

$$C_2 = \frac{0.3183}{FZ} \text{ Farads}$$

$$L_1 = \frac{0.3183Z}{F} \text{ Henrys}$$

Below is given a list of high-pass and low-pass sections having impedances standardized at 600 or 6000 ohms and cut-off frequencies specified as 500, 1000, or 2000 cycles. These individual sections are built into shielding metallic cans and each comprises a suitably designed laminated iron-core inductance unit together with two calibrated wax paper condensers. Any number of similar or different sections may, of course, be joined in series to produce a multi-section filter.

The types listed represent arbitrarily chosen values of impedance and cut-off frequency which find rather extensive use in practice. The General Radio Company specializes in equipment of this sort, and similar sections having any desired electrical constants may be obtained on special order.

GENERAL RADIO COMPANY

Type Number	Form	Iterative Impedance	Cut-off Frequency	Code Word
330-A	Low-Pass	600 Ohms	500 Cycles	FILTERGOAT
330-B	High-Pass	600 Ohms	500 Cycles	FILTERGIRL
330-C	Low-Pass	6000 Ohms	500 Cycles	FILTERSHOE
330-D	High-Pass	6000 Ohms	500 Cycles	FILTERSEAT
330-E	Low-Pass	600 Ohms	1000 Cycles	FILTERTOAD
330-F	High-Pass	600 Ohms	1000 Cycles	FILTERMUSH
330-G	Low-Pass	6000 Ohms	1000 Cycles	FILTERSIGN
330-H	High-Pass	6000 Ohms	1000 Cycles	FILTERPIPE
330-J	Low-Pass	600 Ohms	2000 Cycles	FILTERHEAD
330-K	High-Pass	600 Ohms	2000 Cycles	FILTERFOOT
330-L	Low-Pass	6000 Ohms	2000 Cycles	FILTERBELL
330-M	High-Pass	6000 Ohms	2000 Cycles	FILTERWALK

Type 330 Filter \$12.00

TYPE 355 AMPLIFIER TEST SET



The widespread interest in audio-amplifier characteristics makes the development of a standard and reliable method of taking them highly desirable. The test method should reproduce as nearly as possible the working conditions of the amplifier. It should neither omit any factor tending to affect the characteristic, nor introduce any effects not present in the amplifier.

The coupling device of the audio amplifier is always used in the plate circuit of a vacuum tube whose impedance affects the action of the amplifier very greatly. It is, therefore, necessary that the test instrument either be so arranged that the coupling device is connected in the plate circuit of a vacuum tube, or that the effect of the plate impedance be reproduced in some manner. It is also important that no current be

GENERAL RADIO COMPANY

allowed to flow in the transformer secondary, since even a very slight secondary current will entirely alter the characteristic.

In the Type 355 Amplifier Test Set all the necessary elements of a reliable test set are assembled in a compact unit. All changes in connections are made with quick throw switches. The cabinet also contains the vacuum-tube voltmeter and its plate and grid batteries. The whole unit is assembled in a walnut case with bakelite panel.

The circuit used in the Type 355 Amplifier Test Set was chosen after an examination of the test methods used in a number of leading laboratories. A resistance R_P is used to simulate the impedance in series with the transformer primary. This resistance is variable in 5000-ohm steps and covers the usual range of tube impedances. A vacuum-tube voltmeter is used as a measuring device. The constants of the voltmeter are so adjusted that the grid of the voltmeter tube cannot take current while the galvanometer is on scale.

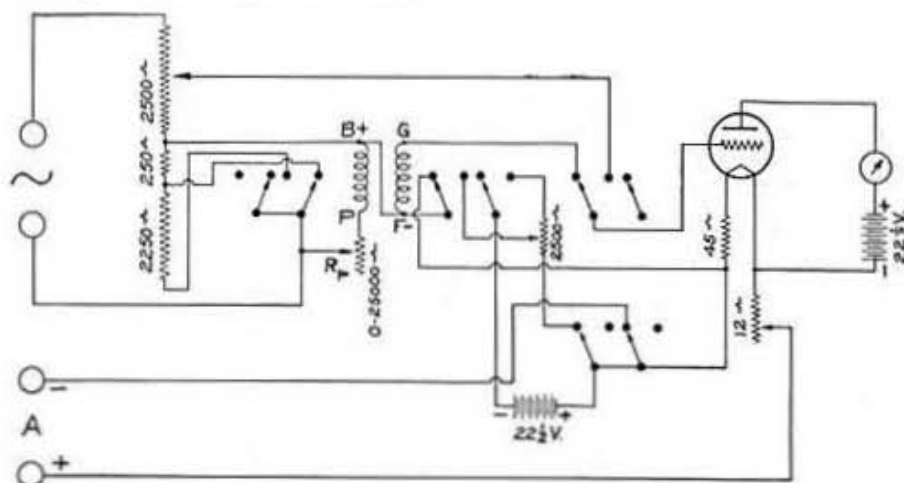

Fig. 1

The input voltage to the transformer under test is taken off across a portion of the high resistance across which the oscillator output is impressed. The remainder of this resistance is used for checking the secondary voltage of the transformer. The voltmeter is used only as a transfer instrument.

In order that the effect of winding capacitances may be reproduced correctly, it is desirable that the B plus and F minus terminals be connected together, so that both will be at ground AC. potential, as under working conditions.

As the vacuum-tube voltmeter is also used to check input voltage, a transfer switch is provided.

The method of test is as follows: The input voltage is adjusted to

GENERAL RADIO COMPANY

the desired value by adjusting the oscillator output. The voltmeter is transferred to the transformer secondary, and the deflection of the galvanometer observed. If the transformer-secondary voltage is high enough to send the galvanometer off scale, an additional adjustable bias is switched in and the meter needle brought on scale. The voltmeter is again switched to the oscillator output, and the potentiometer adjusted until the reading is repeated. The voltage amplification of the transformer is then indicated on the scale attached to the potentiometer.

When impedances, or other coupling devices whose ratios are less than unity, are being checked, a multiplier resistance is connected in circuit.

Amplification factors as high as 1:10 are measurable with this instrument.

OPERATING INSTRUCTIONS. When the test set is received, the panel should be lifted out by removing the eight thumb nuts and lifting straight up. A UX-199 tube should be placed in the socket and the two 22.5-volt dry batteries connected. The dry cells should be Eveready No. 763 or like size. The red wires are connected to the plus battery terminals. The batteries are not connected together. The batteries are held in place by spring clips.

In making amplification measurements with this test set, the following procedure should be followed:

The transformer to be measured is connected to the proper terminals, and connections made to the battery supplying the vacuum-tube voltmeter. The oscillator is connected and placed in operation.

R_r is set at a value corresponding to the plate impedance of the tube which would normally be used with the transformer.

In adjusting the input voltage the position of the switches should be as follows: MULT SCALE—X1; BIAS—OUT; FIL—ON; AMP—AMP. and INPUT VOLTAGE.

The galvanometer is set to zero deflection by adjusting FIL RHEO-STAT while the oscillator is disconnected or inoperative, and the input voltage adjusted as follows: The AMPLIFICATION dial is set to the reciprocal of the desired voltage (0.5 for 2 volts, 1 for 1 volt, 2 for .5 volts, 10 for 0.1 volts, etc.). The oscillator output is adjusted until the voltmeter registers 1 volt. The voltmeter is uncalibrated, but the 1-volt point is marked.

The voltmeter is switched to the transformer by throwing back the fourth switch from the left. If the meter reads off scale, the bias should be thrown in and adjusted to bring the meter on scale. Observe the meter reading and throw the meter transfer switch forward. Adjust the

GENERAL RADIO COMPANY

AMPLIFICATION dial until the meter reading is the same as with the transformer. The figure appearing under the indicator on the AMPLIFICATION scale is the amplification of the transformer.

The process outlined above is repeated for each point on the curve. The input voltage should be checked at each point.

When measuring impedances or other units of which the amplification is less than unity, the X.1 scale multiplier is used. The procedure in measurement is the same as with transformers, except that the reading of the AMPLIFICATION scale in measuring amplification is multiplied by 0.1.

In setting the input voltage the AMPLIFICATION dial should read as follows: For 1 volt read 10, for 2 volts 5, for 5 volts 2, etc.

Impedance coupling units are connected as shown in Fig. 2.

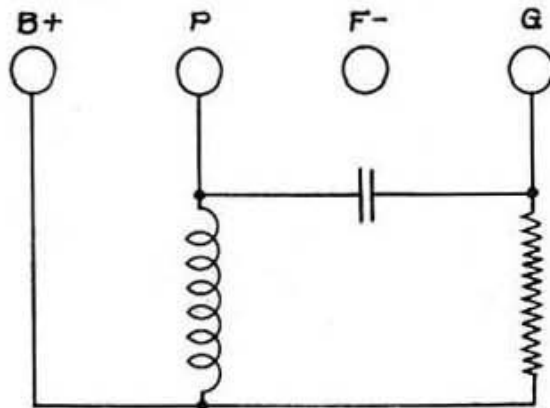

Fig. 2

If it is desired to measure the effect of direct-current saturation in the transformer primary, a battery and meter may be connected externally, in series with the transformer. If this is done, the battery should be disconnected when checking the input voltage.

Type 355 Amplifier Test Set.....\$180.00

Dimensions $9\frac{1}{2}''$ x $5\frac{3}{4}''$ x $16''$. Weight $16\frac{1}{2}$ lbs.

Code Word: ABOVE.

TYPE 338 STRING OSCILLOGRAPH

In many lines of work and experimentation with alternating currents the need is frequently felt for a simple, sensitive, portable, and inexpensive oscillograph, with which one may view with ease either sustained wave forms or transient currents and voltages existing at any point in an electrical circuit or network. To meet this requirement the General Radio Company has designed a compact and moderately priced instrument (the

GENERAL RADIO COMPANY

Type 338 String Oscillograph) which may be used for the following two distinct purposes:

1. As a string oscillograph, which operates with much less power than is usually required by such instruments, but which affords a satisfactory means for the visual examination of wave-forms over a wide range of frequencies. The wave of either current or voltage is traced by the shadow image of a very fine vibrating wire rather than by a spot of light reflected from a mirror attached to a moving system. The vibrating element can, accordingly, be made much lighter, resulting in an increased

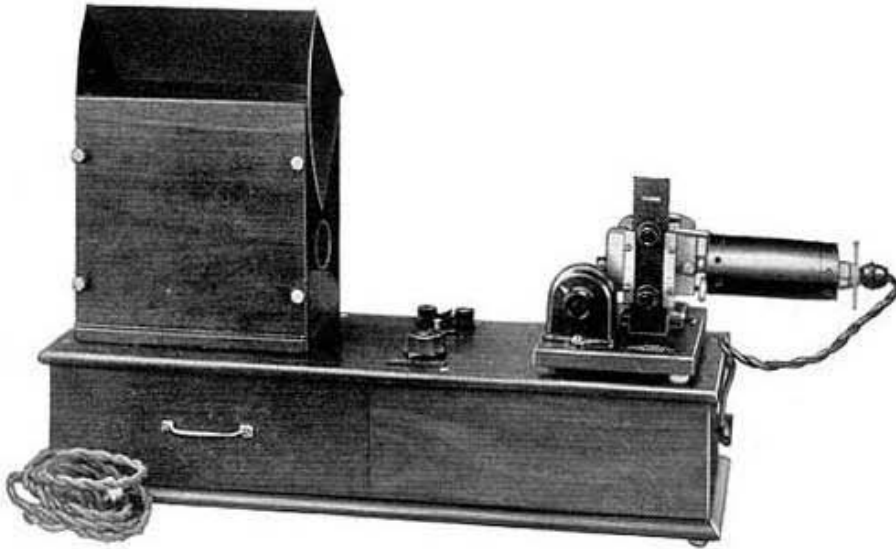

sensitivity of the instrument. The uses for such an instrument are manifold, as, for example, the observation of large or small alternating currents in the laboratory, power house, or class room; the visual examination of telephonic currents in simple or complicated circuits; and, when combined with some form of microphone or magnetophone, the study of mechanical vibration occurring in moving machinery or in bridges or other structures subject to intermittent stresses. For many such lines of work the portable nature of the equipment is of especial value. If the oscillograph is connected in series with the loud-speaker of a radio receiving set, an instructive and entertaining result will be obtained.

2. As a reliable vibration galvanometer, the string of which may be tuned to give a good degree of sensitivity at any desired frequency over a considerable range. In this respect the instrument is especially useful as a null-point detector in AC. bridge measurements when using low frequencies at which the telephone receiver becomes insensitive and otherwise unsatisfactory. Since the galvanometer has no coil in the magnetic field, its

GENERAL RADIO COMPANY

reactance is practically nil when the string is not vibrating, a feature which is desirable for certain applications.

An idea of the sensitivity of the instrument may be obtained from the following data. Using a string of 0.0004-inch tungsten wire, undamped, and tuned to the fundamental of the applied AC. frequency, the following potentials are required to produce a wave-form having an amplitude of one millimeter on the screen:

At 60 Cycles.....	0.2 Millivolt
At 250 Cycles.....	1.0 Millivolt
At 500 Cycles.....	2.4 Millivolts
At 1000 Cycles.....	8.5 Millivolts

The DC. sensitivity of the same string when tuned to various frequencies is seen from the following data, which gives the DC. potentials required to give a deflection of one millimeter on the screen:

At 60 Cycles.....	0.0047 Volt
At 250 Cycles.....	0.065 Volt
At 500 Cycles.....	0.30 Volt
At 1000 Cycles.....	1.31 Volts

The resistance of the instrument strung with the 0.0004-inch tungsten wire is of the order of 45 ohms.

The complete equipment of the string oscillograph comprises the following items:

1. A galvanometer, Type 338-20.
2. A rotating mirror box, Type 338-21.
3. An oscillograph base cabinet, Type 338-22.
4. A carrying-case, Type 338-12, for storing or transporting the instrument readily.
5. A convenient piece of auxiliary apparatus consists of an adjustable rheostat, Type 340, having a total resistance of 100,000 ohms. This rheostat, placed in series with the oscillograph, enables the oscillograph to be used with voltages up to 500. This rheostat, which will be found described on Page 29, and the price of which is \$20.00, is not included in the price of either the complete oscillograph or galvanometer.
6. Another useful piece of auxiliary equipment consists of a step-down transformer, Type 285-N, to adapt the oscillograph so as to obtain efficient operation in high-impedance circuits. This transformer, described on Page 125, is also not included in the complete oscillograph or galvanometer prices. Its price is \$8.00.

The appearance of the instrument may be seen from the photograph. A walnut base cabinet serves to support and to align the

GENERAL RADIO COMPANY

several elements. In the left portion of this is a drawer for holding spare string mounting and other equipment.

The galvanometer is mounted upon the right-hand end of the cabinet. It is sensitized by two permanent magnets, thus eliminating the need of a source of direct current for producing the necessary magnetic field. Two specially shaped pole pieces afford a long, narrow, vertical gap in which the string vibrates, and at the same time serve to support the optical system, which consists of a large and a small condenser lens, together with a microscope objective. The large lens and the standard automobile headlight bulb used are located in the lamp chamber seen on the extreme right, while the two small lenses are located within a tube passing through the pole pieces. All three lenses are adjustable along the optical axis, while the lamp is adjustable in three dimensions. This makes it easy to focus the system to give a uniform field of illumination. A thumbscrew, located on the left end of the lamp chamber, slides the optical system as a whole with reference to the string and thereby focuses the shadow image of the same upon the observing screen.

The string is mounted upon a metal rocker arm, which, in turn, is attached to the rear of a vertical bakelite strip as shown in the photograph. Two adjustment screws will be seen protruding through the front of this strip. One of these varies the tension on the string, while the other serves to move the string across the light beam in order to center the image on the screen. Provision is made for damping the vibration of the string, if desired, by means of a drop of oil. The whole string assembly is readily removed, electrical contact being made through two springs on the galvanometer base. Two string mountings are provided with the equipment, each strung with a fine tungsten wire of about 0.0004-inch diameter. These strings, which are 3 inches in length, may be overloaded considerably without damage. As they carry no mirror, their replacement is a comparatively simple operation.

On the left of the galvanometer base is mounted an enclosed potentiometer for adjusting the potential applied to the string, thereby controlling the amplitude of vibration.

On the left of the cabinet is mounted the mirror box, which is likewise made of walnut. It contains a rotating octagonal metallic mirror which affords the necessary time element of linear motion perpendicular to the vibration. The mirror is mounted on the shaft of a small induction motor and is provided with jewelled bearings. This motor is of simple construction, consisting of a circular disc, the periphery of which passes

GENERAL RADIO COMPANY

through a gap in a rectangular, laminated core. The core is energized by a high-impedance coil carrying a 60-cycle current, and around one-half of the cross section of each pole is a copper ring acting as a "shading coil." The unsymmetrical distortion of the resulting field affords the driving torque. This motor is not inherently synchronous, as its speed may be controlled over a wide range merely by varying the voltage impressed on the energizing coil. This is done by means of a potentiometer, the knob of which is seen in the center of the cabinet. A very constant speed of any desired value may be maintained in this manner, making it easy to synchronize the motor to any frequency impressed on the string, producing thereby a stationary wave pattern. For observing transient phenomena of some duration, it is desirable to have the mirror run quite slowly, whereas the maximum speed of the motor is necessary to separate the individual wave-forms at the higher frequencies. The 60-cycle wavelength at maximum speed is from $2\frac{1}{2}$ to 3 inches, giving a wavelength of about $1/16$ inch at 3000 cycles.

A screen bent on the arc of a circle is seen by looking down into the mirror box, which is provided with an adjustable metallic cover that serves as a hood for shielding the screen when desired. The observer may stand at some distance from the screen and still watch the wave-form while manipulating other apparatus. This is a convenient feature. A cylindrical lens is mounted in the mirror box for concentrating the light beam into a narrow line. This sharpens and intensifies the image considerably. The front vertical wall of the mirror box is easily removable for inspection and adjustment of the enclosed parts.

Terminal posts, together with a cord and plug, are provided for attaching the equipment to a source of 60-cycle, 110-volt current which may be turned on or off conveniently by a small toggle switch mounted on the center portion of the cabinet. This is the only source of power required, since the lamp is lighted through a step-down transformer mounted in the cabinet. The whole instrument takes about 40 watts.

The cabinet contains a 3 MF. paper condenser which is frequently useful for eliminating a DC. component from the string.

Type 338-L Oscillograph, with Carrying Case.....\$225.00

Dimensions 30" x 11" x 17". Weight 61 lbs.

Code Word: OFFER.

When the instrument is desired for use only as a vibration galvanometer, it may be procured without the mirror box, but with a tube having a small translucent screen for observing the image of the vibrating string. In front of this is a small cylindrical lens for concentrating the light beam and intensifying the image. A metallic support is provided

GENERAL RADIO COMPANY

for the outer end of this tube.

Type 338-G Vibration Galvanometer, with Carrying Case.....\$160.00
Dimensions, 30" x 11" x 17". Weight, 53 lbs.
Code Word: OFTEN.

TYPE 338-D DOUBLE STRING HOLDER

The Type 338-D Double String Holder provides two strings, permitting the comparison of two wave-forms. This holder may be substituted for the standard holder, the terminals of one string making contact with the springs on the galvanometer base. The terminals of the other string are brought out to binding posts.

Type 338-D Double String Holder.....\$35.00
Code Word: OLIVE.

TYPE 411-A SYNCHRONOUS MOTOR

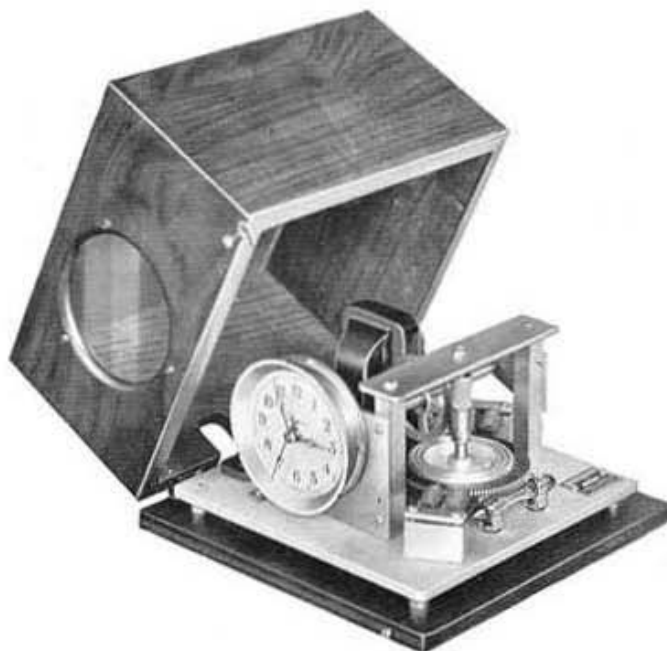

In checking a source of constant-frequency current, great accuracy may be attained by using the source to drive a synchronous motor, and counting the motor revolutions over a long period. Synchronous motors may be built which will operate properly at audio frequencies. Higher frequencies may be checked by stepping down the frequency by means of a series of oscillators, with harmonics of the lower frequency

GENERAL RADIO COMPANY

oscillators adjusted to synchronism with the fundamentals of those of higher frequencies.

The Type 411-A Synchronous Motor is designed for use in calibrating frequency standards by this method. The motor drives a clock movement and when supplied with two-tenths of a volt-ampere at 1000 cycles will keep correct time. The motor will run from any source of 500 to 1800 cycles providing two-tenths of a volt-ampere.

The motor is not self-starting, but must be brought up to correct speed gradually. This is easily done by spinning the knurled portion of the shaft with the finger. The motor will not synchronize if it is run too fast and then is permitted to slow down by its own friction, as the pole pieces do not have a sufficiently strong magnetic effect to overcome the drag thus produced. A neon tube, operated through a transformer from the source, is placed beneath the periphery of the rotor. Looking through the rotor teeth at the neon tube, the teeth will appear to be stationary when the motor is in synchronism. The two grooves in the rotor should be about half filled with mercury to prevent hunting, which is otherwise likely to occur with this type of motor.

The poles are not magnetized and it is, therefore, necessary to have about 10 or 15 milliamperes direct current also flowing through the winding. A satisfactory arrangement is to modulate a UX-171 tube from the source it is desired to measure, then to connect the tube output directly to the motor, without the use of a speaker filter or transformer. The normal plate current of about 12 milliamperes will then magnetize the poles satisfactorily.

In case the motor should get out of adjustment, the location of the four pole pieces should be checked to see that they are opposite their respective rotor projections. The upper and lower bearings in which the steel pivots run are of sapphire, and should be given a drop of clock oil about once in six months. The worm gears and other bearings should also be oiled at the same time. The rotor should run quite freely but without appreciable play in the bearings. This adjustment may be changed readily by loosening the locknut at the top and turning the screw in or out. Each jewel is mounted on a small plunger backed by a spring to prevent damage.

Type 411-A Synchronous Motor \$130.00
Dimensions 8" x 7" x 5". Weight 7 lbs.
Code Word: SEPOY.

GENERAL RADIO COMPANY

TYPE 321 ARTIFICIAL-CABLE BOXES

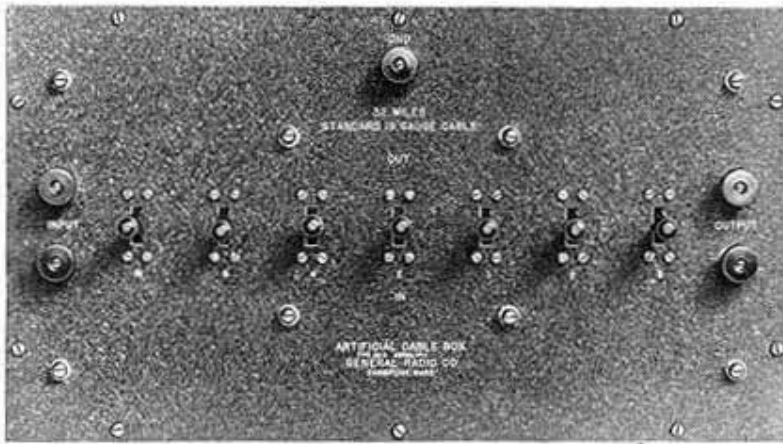

When studying the transmission characteristics of various types of cables it is not always convenient to have an actual cable upon which to experiment. This difficulty may be overcome by employing artificial cable built up of series resistance elements and shunt capacitance elements forming a symmetrical "H-type" section as indicated in the figure.

The loop resistance $4 R$ and the shunt capacitance C of the section are made the same ratio as the loop resistance and shunt capacitance of any given length, say a mile, of the type of cable in question.

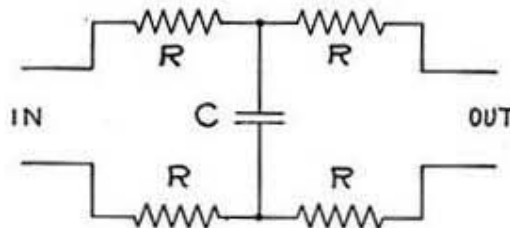

Such a single section may, of course, be made to represent any desired length of cable. An artificial cable will, however, reproduce a real cable in its electrical behavior more perfectly as it is subdivided into a greater number of uniform sections. This fact will be obvious if we consider that the actual cable is composed, electrically, of an infinite number of sections, each having its minute loop resistance and shunt capacitance. That is to say, the electrical constants are distributed uniformly along its length. In practice, however, a limit to this subdivision, as indicated below, is reached at which the artificial cable represents, with a sufficient approximation, the genuine cable.

The amount of inductance present in a cable is so small in compari-

GENERAL RADIO COMPANY

son with the capacitance that its effect at voice frequencies becomes entirely negligible in ordinary methods of testing.

The General Radio Company has developed a series of artificial cable boxes, designated as Type 321 Artificial-Cable Boxes, each containing the electrical equivalent of thirty-two miles of standard paper cable of a gauge frequently used in practice.

This cable is divided into seven units of 16-8-4-2-1-1/2-1/2 mile lengths respectively. By means of seven telephone-key switches any combination of these units may be thrown in or out of the circuit at will. Thus, any desired length of cable up to thirty-two miles may be obtained, in half-mile steps.

In order to represent more accurately an actual cable, the 16, 8 and 4-mile units are built up of the proper number of 2-mile sections; the 2-mile unit is built up of two 1-mile sections and the 1-mile unit of two 1/2-mile sections. The resistance elements of the cable are wound non-inductively and calibrated to within 0.25%, while the capacitance elements, which are high-grade rolled wax paper condensers, have a precision of within 1%. The cable will withstand DC. or peak potentials up to 300 volts.

The terminals of the cable are brought out to input and output binding posts, and the whole assembly is mounted on an aluminum panel and enclosed in a shielded walnut cabinet.

Three different cable boxes have been designed representing side-circuit types of 16, 19 and 22 gauge non-loaded paper cable. The electrical constants at 796 cycles are as follows:

Gauge	Resistance Per Loop Mile	Cap. Per Mile
16 B & S	42.2 Ohms	0.062 MF.
19 B & S	83.2 Ohms	0.062 MF.
22 B & S	171 Ohms	0.073 MF.

For the convenience of those desiring to experiment with longer lengths of cable, the Type 321-D Artificial Cable Box has been designed. This unit contains thirty-two miles of any one of the standard gauges listed above, built as a single unit, with a switch for throwing it in or out of circuit. This unit is a complete assembly of sixteen 2-mile sections.

Type 321-C Artificial-Cable Box \$180.00

Dimensions 15" x 8" x 5 1/2".

Code Word: ACTOR.

Type 321-D Artificial-Cable Box \$150.00

Code Word: ACUTE.

Either type will be built to order.

TRANSFORMERS

A wide variety of transformers of low power rating are used in communication laboratories, and in experimental amplifier construction. These include not only the conventional type of audio frequency coupling transformer for tube coupling, but also line amplifier transformers, impedance-adjusting transformers and low-power transformers.

AUDIO-FREQUENCY TRANSFORMERS

Annealed silicon steel cores are used in all these transformers. The use of adequate quantities of material results in high input impedance at low frequencies without the use of nickel alloys as core material. Precautions against overload are, therefore, not necessary, since no permanent damage will result from saturation of the core. In many of these transformers the windings are split into several sections, the coil being built up of alternate layers of primary and secondary. This type of construction reduces both coil capacity and leakage reactance, preventing undue attenuation of the upper frequencies.

The cases of these transformers are of steel with black japan finish, and with cores and coils sealed in wax.

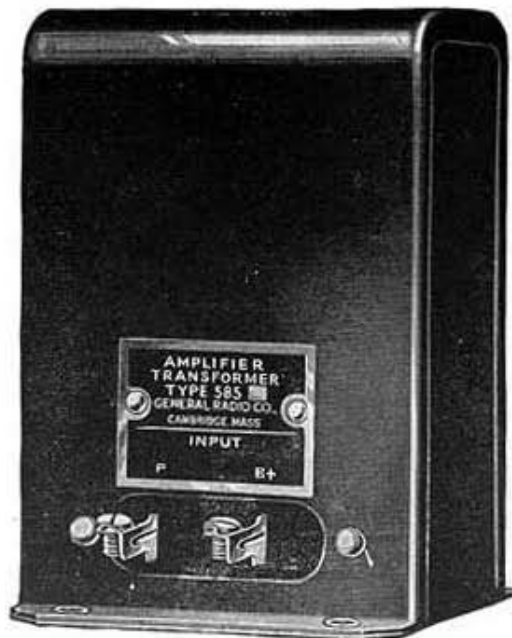

TYPE 585 AMPLIFIER TRANSFORMERS

The Type 585 Amplifier Transformers are high-quality interstage

GENERAL RADIO COMPANY

transformers for use with tubes of plate impedance not exceeding approximately 10,000 ohms.

The Type 585-D Amplifier Transformer has a flat characteristic from 80 to 7000 cycles. At 30 cycles, the amplification is 85% of the maximum value. In the Type 585-H Amplifier Transformer the band of uniform amplification is somewhat narrower, but a higher amplification ratio (1:3.5) is obtained.

Specifications

	Type 585-D	Type 585-H
Primary Inductance	80 Henrys	70 Henrys
Primary DC. Resistance	2000 Ohms	2000 Ohms
Secondary Inductance	320 Henrys	850 Henrys
Secondary DC. Resistance	9300 Ohms	11,000 Ohms
Amplification Ratio	1:2	1:3.5
Permissible Primary Current	5 MA.	5 MA.
Code Word:	TIMID	TIPSY
Type 585 Amplifier Transformer.....		\$7.00
Dimensions, both types, 4½" x 3½" x 2¾". Weight 2¼ lbs.		



TYPE 285 AMPLIFIER TRANSFORMERS

These transformers, while having a narrower uniform amplification band, require less space in a radio set and are lower in price than the Type 585 Amplifier Transformers. These transformers have enjoyed a very wide popularity in experimental radio sets.

Specifications

	Type 285-H	Type 285-D
Turns Ratio	1:6	1:2.7
Primary Inductance	15 Henrys	40 Henrys
Primary DC. Resistance	1200 Ohms	2200 Ohms
Secondary Inductance	525 Henrys	300 Henrys
Secondary DC. Resistance	13,000 Ohms	9000 Ohms
Code Word:	TOKEN	TOTEM
Type 285 Amplifier Transformer.....		\$4.00
Dimensions, both types, 3½" x 3¼" x 2½". Weight 1½ lbs.		

GENERAL RADIO COMPANY

TYPE 373 DOUBLE-IMPEDANCE COUPLER

While not a transformer, the use to which the Type 373 Double-Impedance Coupler is put places it in this classification. This unit consists of two chokes with a condenser, assembled in a unit, the chokes forming plate and grid reactances and the condenser being used for coupling. The condenser is designed to give resonance at about 60 cycles, thus raising the lower end of the frequency characteristic. The impedance in the grid circuit has the advantage of reducing the tendency toward grid blocking.

This coupler is manufactured under U. S. Patent 1,589,692.

Each choke has an inductance of 55 henrys and a direct-current resistance of 4500 ohms. The capacity of the coupling condenser is 0.1 MF.

Type 373 Double-Impedance Coupler . . . \$4.50

Dimensions $4\frac{1}{2}'' \times 3\frac{1}{2}'' \times 2\frac{3}{4}''$.

Weight $2\frac{1}{2}$ lbs.

Code Word: JELLY.



PUSH-PULL TRANSFORMERS

When a greater output than is available from a single tube is required, the push-pull form of amplifier is recommended. The push-pull connection permits each tube to be worked over a greater portion of its characteristic for a given degree of distortion than does the usual connection. The resultant power is not limited to twice that for a single tube. A further advantage of the push-pull method is that hum voltages tend to cancel in installations where unrectified alternating current is used on the filaments of the amplifier tubes.

The voltage amplification of the push-pull stage is substantially the same as for a stage of conventional transformer design. The push-pull amplifier is recommended where a substantial signal voltage is available and large power output without distortion is required. A push-pull amplifier is not a high-gain stage and does not of itself create great volume.

The General Radio push-pull amplifiers are licensed by the Radio

GENERAL RADIO COMPANY

Corporation of America and associated companies for radio amateur, experimental and broadcast reception only.

TYPE 441 PUSH-PULL AMPLIFIER

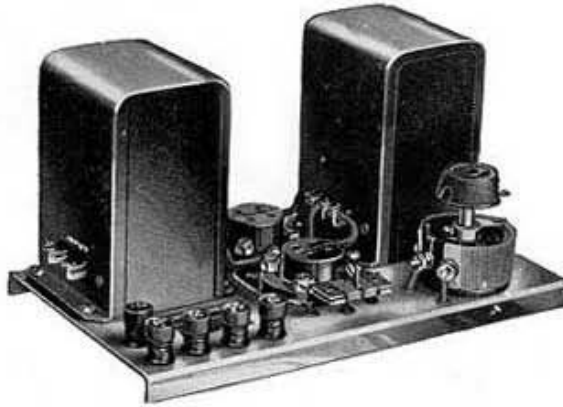

The Type 441 Push-Pull Amplifier is designed for use with the tubes of smaller power output, such as the Types 112, 226, 171 and 210. It is a completely assembled and wired unit, including baseboard, sockets and rheostat, ready for installation. In order to obtain the full output of the tube, a signal voltage of 15 is required for 171 tubes, while for 112 or 226 tubes the input signal voltage should be about 6.

The inductance of the input transformer primary is 20 henrys. Its turns ratio is 1:2.25 for each side. The DC. resistance of the primary of this transformer is 1600 ohms.

The impedance ratio for the output transformer is 10:1 (whole primary to secondary). The DC. resistance of the primary of the output transformer is 850 ohms.

Type 441 Push-Pull Amplifier \$15.00
Dimensions 9" x 5 $\frac{1}{4}$ " x 5". Weight 5 $\frac{1}{2}$ lbs.

Code Word: ASIDE.

Type UX-226 or CX-326 Amplifier Tube.....\$2.25
Type UX-171 or CX-371 Amplifier Tube..... 2.75
Type UX-210 or CX-310 Amplifier Tube..... 9.00

TYPE 541 PUSH-PULL AMPLIFIER TRANSFORMERS

When power tubes having plate currents considerably in excess of 25 milliamperes, such as the Type CX-350 or Type UX-250, are being used, the Type 441 Push-Pull Transformers are not suitable. These tubes require transformers of special design, and the Type 541 Push-Pull

GENERAL RADIO COMPANY



Amplifier Transformers are supplied for this purpose. It should be noted that the use of the Type 541 Push-Pull Amplifier Transformers is not limited to the 250 tubes, but that they may be used also with other power tubes having plate impedances of 2000 to 6000 ohms.

The design of a push-pull input transformer offers considerable difficulty, due to the fact that each half of the double secondary

must have equal coupling to the primary. In the Type 541-A Input Transformer, the windings have been split into several sections and a sandwich type of coil used, which results in an unusually good characteristic. The curve is flat from 100 to 10,000 cycles, dropping to about 75% of the maximum at 30 cycles.



The increasing use of low-impedance speakers of the so-called dynamic type, particularly with the larger power tubes, has made necessary the development of a special output transformer for these speakers. The Type



541 Push-Pull Amplifier Transformers are, therefore, obtainable in two combinations, each package containing an input and an output transformer, i. e., a Type 541-A and a Type 541-B Transformer for use where the speaker impedance is of the order of 2000 to 3000 ohms, or a Type 541-A and a Type 541-C Transformer for use where the speaker impedance is of the order of 5 to 10 ohms.

GENERAL RADIO COMPANY

Specifications

	Type 541-A	Type 541-B
Primary Inductance	65 Henrys	35 Henrys
Permissible Primary Current	6 MA.	60 MA. each side
Turns Ratio (primary to whole secondary)	1:3	1.2:1
Primary DC. Resistance	1750 Ohms	750 Ohms (whole)
Dimensions	4 $\frac{1}{4}$ " x 3 $\frac{1}{2}$ " x 3"	4 $\frac{1}{4}$ " x 3 $\frac{5}{8}$ " x 4 $\frac{1}{2}$ "
Weight	2 $\frac{1}{4}$ lbs.	3 lbs.

The electrical specifications for the Type 541-C Output Transformer are the same as for the Type 541-B Output Transformer, except for the turns ratio, which is 35:1 (whole primary to secondary). The case dimensions are the same as for the Type 541-A Input Transformer.

Type 541-A and Type 541-B Push-Pull Amplifier Transformers

(for Standard Speaker) \$25.00

Code Word: TALLYTORSO.

Type 541-A and Type 541-C Push-Pull Amplifier Transformers

(for Dynamic Speaker) \$25.00

Code Word: TALLYTAPER.

OUTPUT DEVICES

Output coupling devices are required for two purposes, to adjust the load to the optimum apparent impedance, and to prevent damage to the load due to the flow of a large plate current. Devices of the first class must be transformers, while devices of the second class may be either transformers or condenser-choke filters. Transformers for impedance adjusting should have an input impedance which is high as compared to the reflected load impedance. The following listings contain output devices of both classes.

TYPE 585-O OUTPUT TRANSFORMER

The Type 585-O Output Transformer is intended for use between the plate circuits of power tubes of 2000 to 5000 ohms impedance, and dynamic speakers having an impedance of 5 to 10 ohms. This transformer will operate without impairment of audio quality with a direct current of 55 milliamperes in the primary and is, therefore, adapted for use with the Type UX-250 tube. This transformer is identical in size and appearance with the Type 541-A Push-Pull Amplifier Transformer. It has a primary DC. resistance of 464 ohms and a secondary DC. resistance of 1.87 ohms. Its impedance ratio is 625:1.

Type 585-O Output Transformer \$7.00

Dimensions 4 $\frac{1}{2}$ " x 3 $\frac{1}{2}$ " x 2 $\frac{3}{4}$ ". Weight 2 $\frac{1}{4}$ lbs.

Code Word: TITLE.

GENERAL RADIO COMPANY

Type 587-B SPEAKER FILTER

The Type 587-B Speaker Filter is intended for use in the output of such power tubes as the CX-350 or UX-250 where the plate current is large, but the tube impedance is so low that no adjustment of impedance is needed. The Type 587-B Speaker Filter is suitable for use following impedances of 2000 to 10,000 ohms. Where a dynamic speaker is used as a load, a Type 585-O Output Transformer would be required.



The Type 587-B Speaker Filter contains a choke coil of 30 henrys inductance and 550 ohms DC. resistance. The direct current through the coil should not exceed 100 milliamperes. A 4-MF. condenser is connected in each speaker lead.

Type 587-B Speaker Filter \$9.00

Dimensions $4\frac{1}{4}''$ x $3\frac{5}{8}''$ x $4\frac{1}{2}''$. Weight 4 lbs.

Code Word: FATAL.

TYPE 387-A SPEAKER FILTER

In installations where the plate currents do not exceed 20 to 30 milliamperes, as when a type 112, 171 or 210 tube is used, a speaker filter of lower current capacity may be used. The Type 387-A Speaker Filter fills the requirements of such installations. It contains a choke coil of 30 henrys inductance and 350 ohms DC. resistance. The direct current through the coil should not exceed 30 milliamperes. A 2-MF. condenser inside the case is connected in one speaker lead.

Type 387-A Speaker Filter \$4.50

Dimensions $4\frac{1}{4}''$ x $3\frac{1}{2}''$ x $3''$. Weight $2\frac{1}{2}$ lbs.

Code Word: TOWEL.

TYPE 367 OUTPUT TRANSFORMER

Where a slight change in the apparent load impedance is desirable, in addition to keeping direct current out of the speaker windings, the Type 367 Output Transformer is satisfactory. It is intended for use in the plate circuit of 6000 to 10,000-ohm tubes, and its impedance ratio

GENERAL RADIO COMPANY

of 1.5:1 is suitable for feeding 4000 to 5000-ohm speakers from such a tube. This transformer has a primary inductance of 12 henrys and a primary DC. resistance of 325 ohms. It has a secondary inductance of 10 henrys and a secondary DC. resistance of 375 ohms. The direct current through the primary should not exceed 10 milliamperes.

Type 367 Output Transformer \$3.50

Dimensions $3\frac{1}{2}''$ x $3\frac{1}{4}''$ x $2\frac{1}{2}''$. Weight $1\frac{1}{2}$ lbs.

Code Word: TESTY.

MICROPHONE AND LINE-AMPLIFIER TRANSFORMERS

Microphone and line-amplifier transformers, for microphone coupling and for use in telephone lines respectively, are also available. These transformers are similar in general design and appearance to the amplifier transformers previously described.

TYPE 585-M

SINGLE-BUTTON MICROPHONE-TO-GRID TRANSFORMER

A high-quality transformer of the proper impedance ratio is required to adjust the low impedance of 100-ohm single-button microphones to the grid impedance of the first-stage amplifier tube. The Type 585-M Single-Button Microphone-to-Grid Transformer is designed to fill these requirements. This transformer has a primary inductance of 0.95 henrys and a primary DC. resistance of 20 ohms. The turns ratio is 1:27. A resistance of 100,000 ohms is shunted across the secondary within the case.

Type 585-M Single-Button Microphone-to-Grid Transformer . . . \$12.00

Dimensions $4\frac{1}{2}''$ x $3\frac{1}{2}''$ x $2\frac{3}{4}''$. Weight $2\frac{7}{8}$ lbs.

Code Word: TARDY.

TYPE 585-M2

DOUBLE-BUTTON MICROPHONE-TO-GRID TRANSFORMER

Whenever a double-button microphone is used, a split winding is required on the primary of the transformer. The Type 585-M2 Double-Button Microphone-to-Grid Transformer is similar in its general characteristics to the Type 585-M Transformer, except that proper provision has been made for the use of a double-button microphone. Each winding of this transformer has a primary inductance of 0.95 henrys and a primary DC. resistance of 32 ohms.

Type 585-M2 Double-Button Microphone-to-Grid Transformer . . \$12.00

Dimensions $4\frac{1}{2}''$ x $3\frac{1}{2}''$ x $2\frac{3}{4}''$. Weight $2\frac{7}{8}$ lbs.

Code Word: TARRY.

GENERAL RADIO COMPANY

TYPE 284 LINE-AMPLIFIER TRANSFORMERS

The Type 284 Line-Amplifier Transformers are designed for use with line amplifiers, as the coupling unit between the plate of an amplifier tube and the line, and between the line and the grid of an amplifier tube. They are designed for a 500 to 600-ohm line impedance.

Type 284-D Plate-to-Line Coupling Transformer \$12.00
Turns ratio 3.6:1

Code Word: PETTY.

Type 284-E Telephone Line-to-Grid Coupling Transformer \$12.00
Turns ratio 1:7.3

Code Word: PIGMY.

Dimensions $4\frac{1}{2}''$ x $3\frac{1}{2}''$ x $2\frac{3}{4}''$. Weight $2\frac{1}{4}$ lbs.

IMPEDANCE-ADJUSTING TRANSFORMERS FOR MEASURING AND BRIDGE CIRCUITS



The sensitivity of bridge measurements can be increased greatly by means of an impedance-adjusting transformer, if the bridge circuit differs greatly in impedance from the measuring instrument. In coupling other circuits, an adjustment in impedance is also required in order to get maximum power from a source to a load. A number of variable-ratio impedance-adjusting transformers have been developed, as well as a few fixed-ratio transformers for specific needs.

TYPE 359 VARIABLE-RATIO TRANSFORMERS

These transformers are supplied in two groups, to work out of relatively high impedances, 5000 to 20,000 ohms, or to work out of 500 to 600-ohm circuits. Efficiency is maintained down to 60 cycles in each case. Both auto transformers and two-winding transformers are available. All types are provided with jack-top binding posts to fit the Type 274 Plugs,

GENERAL RADIO COMPANY

a convenient feature which facilitates circuit changes. The ratio is changed by means of a tap switch on which is engraved the secondary-to-primary turns ratio. The transformers are furnished in the following ratios:

To Work Out of 5000 to 20,000 Ohms Impedance

Type 359-A Transformer

Turns ratio 0.25, 0.35, 0.5, 0.7, 1.0, 1.4.

Code Word: PILOT.

Type 359-B Transformer

Turns ratio 0.06, 0.09, 0.13, 0.18, 0.25, 0.35.

Code Word: PIOUS.

Type 359-C Auto Transformer

Turns ratio 0.25, 0.35, 0.5, 0.7, 1.0, 1.4.

Code Word: PIVOT.

Type 359-D Auto Transformer

Turns ratio 0.06, 0.09, 0.13, 0.18, 0.25, 0.35.

Code Word: PLAZA.

To Work Out of 500 to 600 Ohms Impedance

Type 359-E Transformer

Turns ratio 0.25, 0.35, 0.5, 0.7, 1.0, 1.4.

Code Word: POKER.

Type 359-F Transformer

Turns ratio 0.06, 0.09, 0.13, 0.18, 0.25, 0.35.

Code Word: POLAR.

Type 359-G Auto Transformer

Turns ratio 0.25, 0.35, 0.5, 0.7, 1.4.

Code Word: POLKA.

Type 359-H Auto Transformer

Turns ratio 0.06, 0.09, 0.13, 0.18, 0.25, 0.35.

Code Word: POPPY.

Type 359 Variable-Ratio Transformers\$20.00

Dimensions $3\frac{5}{8}$ " x $4\frac{1}{2}$ " x $4\frac{1}{8}$ ". Weight $3\frac{1}{2}$ lbs.

GENERAL RADIO COMPANY

TYPE 166 TELEPHONE TRANSFORMERS



For many purposes in a laboratory a small iron core transformer of high and adjustable impedance is extremely useful. It may be used to advantage in impedance bridges employing a telephone receiver to detect the balance point. With this transformer it is possible to adjust the impedance of the telephone circuit to the most satisfactory value for the bridge circuit, independent of the telephone receiver impedance.

The winding is all on one leg of the core, but is in two separate parts so as to be used as a primary and secondary. These windings, however, may be connected in series should it be desired to use an auto transformer connection. Taps are brought out on both the primary and secondary windings so that it is possible to vary the impedance and the ratio of transformation. A small air gap is left in the iron core to prevent any possible distortion of wave-form due to saturation of the iron. The panel is of bakelite with engraved lettering. Nickel-plated binding posts are used as terminals for the taps. The following table shows the number of turns between each set of binding posts:

PRIMARY	SECONDARY
1-2.....150 Turns	5-6.....1200 Turns
2-3.....300 Turns	6-7.....2400 Turns
3-4.....600 Turns	7-8.....4800 Turns

Type 166 Telephone Transformer.....\$7.00

Dimensions $2\frac{3}{4}$ " x $2\frac{1}{2}$ " x $2\frac{1}{4}$ ". Weight 2 lbs.

Code Word: TOPIC.

GENERAL RADIO COMPANY

TYPE 285-N TRANSFORMER

This transformer is designed to adjust the impedance of the Type 338 Oscillograph string circuit, which is approximately 45 ohms, to a high-impedance measuring circuit. The impedance ratio is 325:1, and the transformer is designed to work into a load of 30 to 60 ohms.

Type 285-N Transformer \$8.00

Dimensions $3\frac{1}{2}'' \times 3\frac{1}{4}'' \times 2\frac{1}{2}''$. Weight $1\frac{1}{2}$ lbs.

Code Word: OBESE.

POWER TRANSFORMERS

Small power transformers are required for vacuum-tube excitation, both for plate supply, through a rectifier and filter, and for filament supply. A variety of transformers of both types is available. All these transformers are sealed with wax to eliminate hum from lamination vibration, and are contained in black japanned pressed-steel cases.

TYPE 565 TRANSFORMERS



The Type 565 Transformers are intended for use in high-voltage power equipment for supplying such tubes as the Type UX-210 (CX-310) and UX-250 (CX-350), and for use in amateur transmitters. These transformers have a 200-watt rating. They are designed for operation from 105 to 125-volt, 50 to 60-cycle lines, and are available with the following secondary voltages based on 115 volts primary input.

Type 565-A Half-Wave Transformer \$13.50

Secondary voltages	600 Volts	7.5 Volts	7.5 Volts	2.25 Volts
Maximum current	200 MA.	2.5 Amperes	2.5 Amperes	4 Amperes

Code Word: TABOO.

Type 565-B Full-Wave Transformer \$13.50

Secondary voltages	1200 Volts (with center tap)	7.5 Volts	7.5 Volts
Maximum current	200 MA	2.5 Amp.	2.5 Amp.

Code Word: TACIT.

Dimensions, both types, $5\frac{3}{4}'' \times 5\frac{1}{4}'' \times 5\frac{1}{4}''$. Weight $14\frac{1}{4}$ lbs.

[127]

GENERAL RADIO COMPANY

TYPE 365 PLATE-SUPPLY TRANSFORMER



For low-voltage plate supplies, intended for service with amplifiers using UX-171 (CX-371) or similar power tubes, a power transformer of lower voltage and power rating than the Type 565 Transformer is required. The Type 365 Plate-Supply Transformer is designed for use as a power-supply transformer in such equipment. It is intended for use on 105 to 125-volt, 50 to 60-cycle lines. The power rating is 70 watts. Secondary voltages are 550 (100 milliamperes, maximum) with a center tap, and 7.5 (2.5 amperes, maximum).

Type 365 Plate-Supply Transformer \$6.00
Dimensions $4\frac{1}{2}'' \times 3\frac{5}{8}'' \times 4\frac{1}{2}''$. Weight $4\frac{1}{2}$ lbs.
Code Word: TENOR.

TYPE 440-A LOW-VOLTAGE TRANSFORMER

The Type 440-A Low-Voltage Transformer is primarily intended for filament supply of alternating-current tubes. Like the other power transformers, it is designed for use on 105 to 125-volt, 50 to 60-cycle lines. The power rating is 70 watts. The following voltages are available: 2—3.5—5—7.5. All windings are separate.

Type 440-A Low-Voltage Transformer \$7.00
Dimensions $4\frac{1}{4}'' \times 3\frac{5}{8}'' \times 4\frac{1}{2}''$. Weight $4\frac{1}{2}$ lbs.
Code Word: TIGER.

TYPE 445 PLATE-SUPPLY AND GRID-BIAS UNIT

The increasing use of high plate voltages on vacuum tubes makes the use of a plate-supply unit advisable in the laboratory. The economy of such a unit is particularly marked where the use of the plate supply is infrequent, involving deterioration of batteries when not in use.

The Type 445 Plate-Supply and Grid-Bias Unit has been designed to meet the demand for a thoroughly dependable light socket "B" power unit that is readily adaptable to the requirements of standard tubes. Any combination of voltages from 0 to 180 may be taken from the four positive "B" terminals. An adjustable grid-bias voltage from 0 to 50 is also available for use on the power tube of an amplifier.



Type 445 Plate-Supply and Grid-Bias Unit

Voltages are varied by moving adjustable clamps with thumbscrews along a wire-wound resistance. When the clamps are set for the proper operating voltages of the tubes, the thumbscrews are tightened, but may easily be readjusted to meet new requirements.

To make the unit absolutely safe even in the hands of persons not familiar with electrical devices, an automatic cut-out switch is provided which breaks the 110-volt AC. circuit when the cover is removed for adjusting voltages or connecting wires to binding posts. The Type 445 Plate-Supply and Grid-Bias Unit is designed for use on 105 to 125-volt, 50 to 60-cycle lines, and uses a Type UX-280 (CX-380) Rectifier Tube. The circuits of the unit are connected to the case through a condenser, rather than directly, in order to obviate the possibility of short-circuiting the filament battery. The case is of pressed steel, finished in brown crackle lacquer.

Type 445 Plate-Supply and Grid-Bias Unit \$35.00

Dimensions 15 $\frac{1}{4}$ " x 7" x 7". Weight 16 lbs.

Code Word: APPLE.

Type UX-280 or CX-380 Rectifier Tube.....\$4.25

This unit is licensed by the Radio Corporation of America and associated companies for radio amateur, experimental, and broadcast reception only.

GENERAL RADIO COMPANY

TYPE 527-A RECTIFIER FILTER

The Type 527-A Rectifier Filter is a complete filter for heavy-duty plate-supply units, incorporating two chokes and a condenser assembly of 4-2-4 MF. Each choke has an inductance of approximately 15 henrys, and a current-carrying capacity of 100 milliamperes. The DC. resistance is 175 ohms for each choke. The condensers are rated at 1000 volts continuous service. The filter is similar in appearance to the Type 565 Transformers. Connections are in the form of wire leads. It is mounted in a pressed-steel case with black japan finish.



Type 527-A Rectifier Filter \$17.50

Dimensions 5¾" x 5¼" x 5¼". Weight 9½ lbs.

Code Word: FATTY.

— OO —

In assembling equipment for the laboratory, small parts, such as sockets, binding posts, knobs, dials, etc., are required. For the convenience of laboratories assembling instruments for their own use we are listing the various standard parts used in our own equipment.

TYPES 260 AND 280 PORCELAIN INSULATORS

For antenna insulation, correctly designed porcelain strain insulators are to be preferred to other commercial types. The Type 280 Strain Insulator, illustrated, will be found particularly satisfactory. It is made of carefully glazed brown porcelain and will withstand severe weather conditions.



Type 260

Type 280

Type 280 Strain Insulator \$.12

Dimensions 4½" x 1⅛" x 1". Weight 4 oz.

Code Word: CRULLER.

GENERAL RADIO COMPANY

Another convenient insulator is the Type 260 Wall Insulator. It may be used inside to support wiring or instruments, or may be used outside for supporting lead-ins or ground wires. Two of these insulators with a threaded rod connecting them make an excellent lead-in combination. Since they are also constructed of glazed brown porcelain, they may be used either indoors or out.

Each insulator is equipped with nuts and washers assembled, as illustrated.

Type 260 Wall Insulator \$.20
 Dimensions $2\frac{1}{8}''$ x $2\frac{1}{8}''$ x 2". Weight 4 oz.
 Code Word: CONIC.

DIALS

The General Radio dials are of brass, finished to resemble frosted silver, with graduated scale in black. The Type 302 and 303 Dials are provided with a specially designed vernier attachment, consisting of a fiber pinion mounted below the dial, and engaging with a gear behind the dial. The pinion is mounted on a floating arm, and is held in close contact with the gear by means of a spring. The pinion is mounted on the front of the panel, and but one mounting hole is required for the entire vernier attachment.

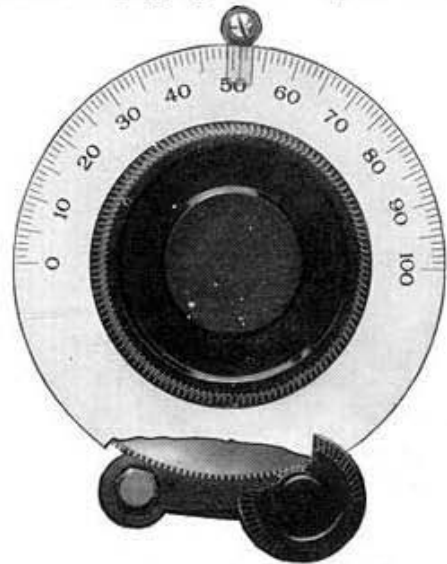

The Type 310 and 317 Dials are similar to the Type 302 and 303 Dials, but do not have the vernier attachment.

Each dial is packed with celluloid indicator, and a template is provided for mounting. All dials are designed for a $\frac{1}{4}$ inch shaft.

Type 302- $2\frac{3}{4}''$ Geared Dial \$1.25
 Dimensions $3\frac{1}{2}''$ x $\frac{3}{4}''$. Weight 6 oz.
 Code Word: DAISY.
 Type 303-4" Geared Dial \$2.00
 Dimensions $4\frac{5}{8}''$ x $\frac{3}{4}''$. Weight 10 oz.
 Code Word: DALLY.

GENERAL RADIO COMPANY

Type 310-2 $\frac{3}{4}$ " Dial \$.50

Dimensions 2 $\frac{3}{4}$ " x $\frac{5}{8}$ ". Weight 3 $\frac{1}{2}$ oz.

Code Word: DANDY.

Type 317-4" Dial \$1.00

Dimensions 4" x $\frac{3}{4}$ ". Weight 6 $\frac{1}{2}$ oz.

Code Word: DEBUT.

SOCKETS

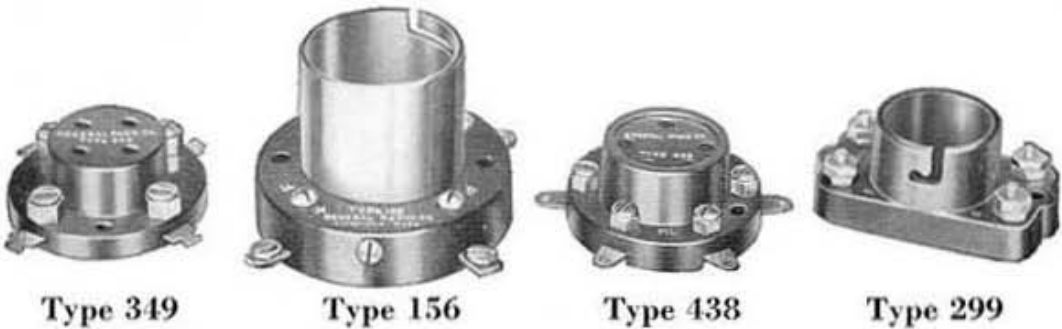

In the design of all General Radio sockets, care has been taken in each case to make the sockets meet specifically the requirements of the tubes with which they are to be used. Moulded parts are of bakelite and metal parts are nickel plated, with the exception of soldering terminals, which are nickel silver, for easier soldering.

TYPE 156 SOCKET

This socket is designed for tubes having the large UV or UX-base. The phosphor-bronze contact springs are so arranged as to make positive contact on the sides of the tube prongs.

Type 156 Socket \$.75

Dimensions 2 $\frac{1}{2}$ " x 2 $\frac{1}{2}$ " x 1 $\frac{3}{4}$ ". Weight 4 oz.

Code Word: SOBER.

TYPE 299 SOCKET

The Type 299 Socket is designed for the UV-199 tube. A multiple spring makes contact to the bottom of the tube prongs.

Type 299 Socket \$.35

Dimensions 2 $\frac{3}{8}$ " x 1 $\frac{3}{8}$ " x 1". Weight 2 oz.

Code Word: STORY.

GENERAL RADIO COMPANY

TYPE 349 SOCKET.

This socket is designed for the UX-type of tubes. Positive contacts are made with double gripping springs to the sides of the tube prongs.

Type 349 Socket \$.35

Dimensions 2 1/4" x 2 1/4" x 3/4". Weight 2 oz.

Code Word: SEDAN.

TYPE 438 SOCKET

The Type 438 Socket is designed for use with a tube having a five-prong base. In construction it is similar to the Type 349 Socket.

Type 438 Socket for UY-base tubes \$.35

Dimensions 2 1/2" x 2 1/2" x 3/4". Weight 2 oz.

Code Word: STUDY.



Type 309



Type 346

TYPE 346 ADAPTER

The Type 346 Adapter enables the UX-199 and UX-120 tubes to be used in navy standard tube sockets (Type 156). The adapter is of moulded bakelite. A setscrew is provided for securing the tube firmly in the adapter.

Type 346 Adapter \$.20

Dimensions 1 1/2" x 1 1/2" x 7/8". Weight 1 oz.

Code Word: AMASS.

TYPE 309 SOCKET CUSHION

Many of the undesirable noises heard in a radio set are due to the microphonic action of the tubes. This condition may be somewhat reduced by the use of the Type 309 Socket Cushion under the Types 156, 299, 349 and 438 Sockets. This cushion is of sponge rubber.

Type 309 Socket Cushion \$.25

Dimensions 2 1/4" x 2 1/2" x 3/8". Weight 1 oz.

Code Word: SABER.

GENERAL RADIO COMPANY

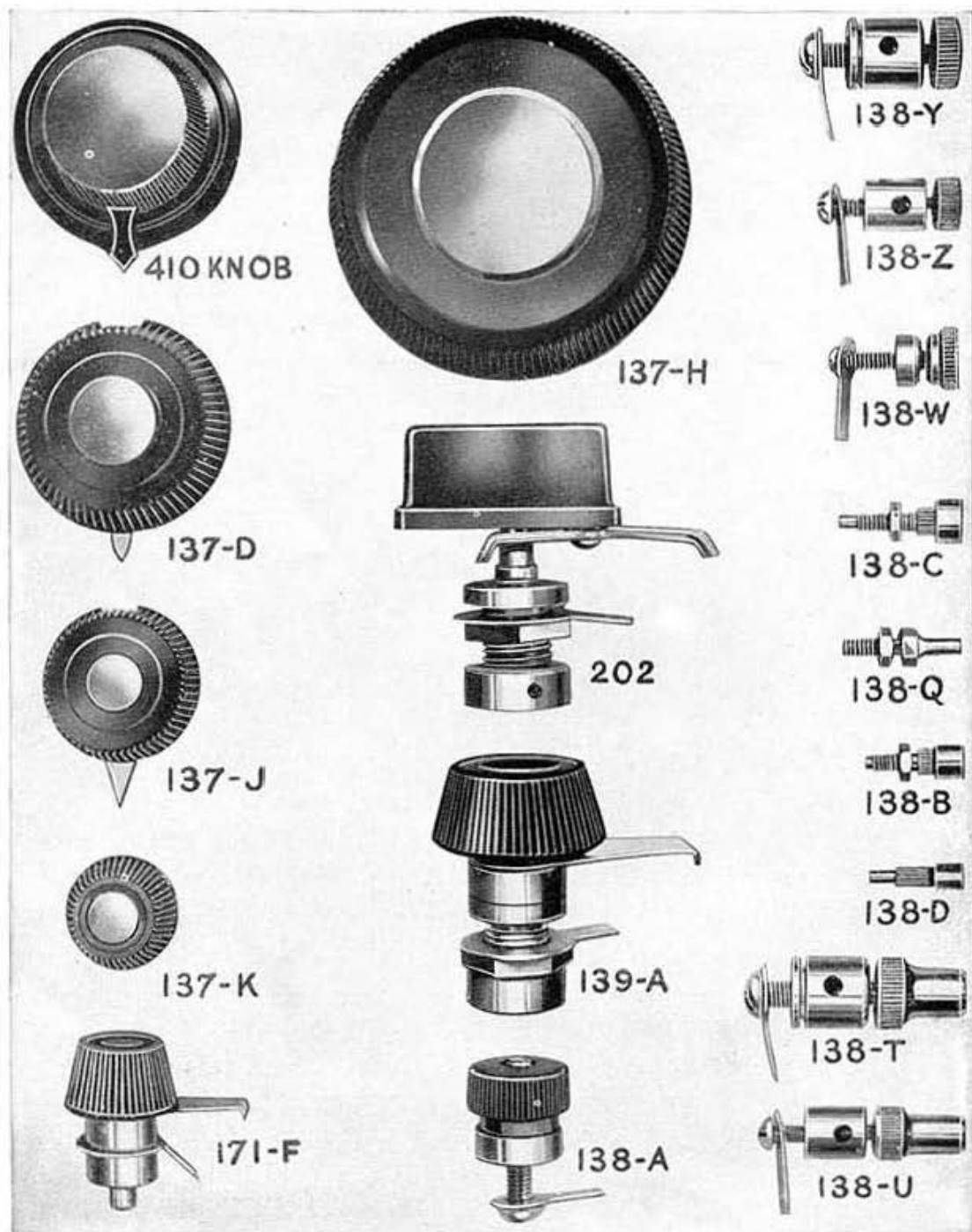

MISCELLANEOUS PARTS

All metal parts are nickel plated. Knobs and other moulded parts are of bakelite.

GENERAL RADIO COMPANY

BINDING POSTS

Type	Description	Diameter	Height	Screw Size	Price
138-A	Bakelite	3/4"	5/8"	10-32	\$.18
138-W	N. P. Brass	7/16"	1/2"	6-32	.08
138-Y	N. P. Brass	1/2"	3/4"	10-32	.14
138-Z	N. P. Brass	3/8"	5/8"	6-32	.07

BINDING-POST TOPS

Type	Description	Price
138-T	Jack-Top Binding Post, for use with Type 274 Plug.....	\$.16
138-U	Jack-Top Binding Post, for use with Type 274 Plug.....	.10

SWITCH CONTACTS AND STOPS

Type	Description	Price
138-B	1/4" Contact for Type 171-F Switch.....	\$.04
138-C	5/16" Contact for Type 139-A or 202 Switch.....	.04
138-D	3/16" Contact for Type 171-F Switch.....	.03
138-Q	Switch Stop, with nut.....	.04

SWITCHES

Type	Description	Price
139-A	Multiple-Leaf Switch 1 3/8" Radius.....	\$.50
171-F	Single-Leaf Switch 7/8" Radius.....	.30
202-A	Low Contact Resistance Switch 1 3/8" Radius, for panels up to 1/4".....	.75
202-B	Low Contact Resistance Switch 1 3/8" Radius, for panels up to 3/8".....	.75

KNOBS

Type	Description	Price
137-D	Moulded Knob, with pointer.....	\$.30
137-D	Moulded Knob, without pointer, (same as used on Type 139-A Switch) ..	.25
137-H	Moulded Knob, (same as used on Type 317 Dial).....	.50
137-J	Moulded Knob, with pointer, (same as used on Type 301 Rheostat)....	.20
137-J	Moulded Knob, without pointer.....	.15
137-K	Moulded Knob, (same as used on Type 247 Vernier, tap 10-32 hole)....	.15
410	Moulded Knob, with pointer, (same as used on Type 410 Rheostat)....	.20

TYPE 337 SWITCHES

The experimenter will find the Type 337 Switches convenient for experimental work. The construction is such that a quick change-over may be effected.

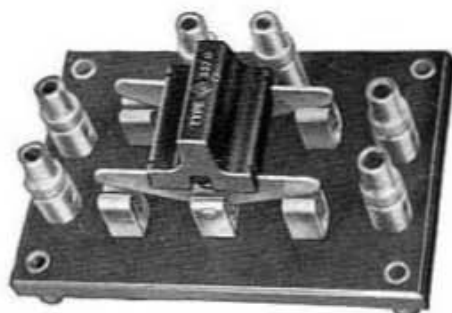

Type 337-A	DPDT Switch	\$ 3.00
Type 337-B	4PDT Switch	7.00
Type 337-C	6PDT Switch	10.00

GENERAL RADIO COMPANY

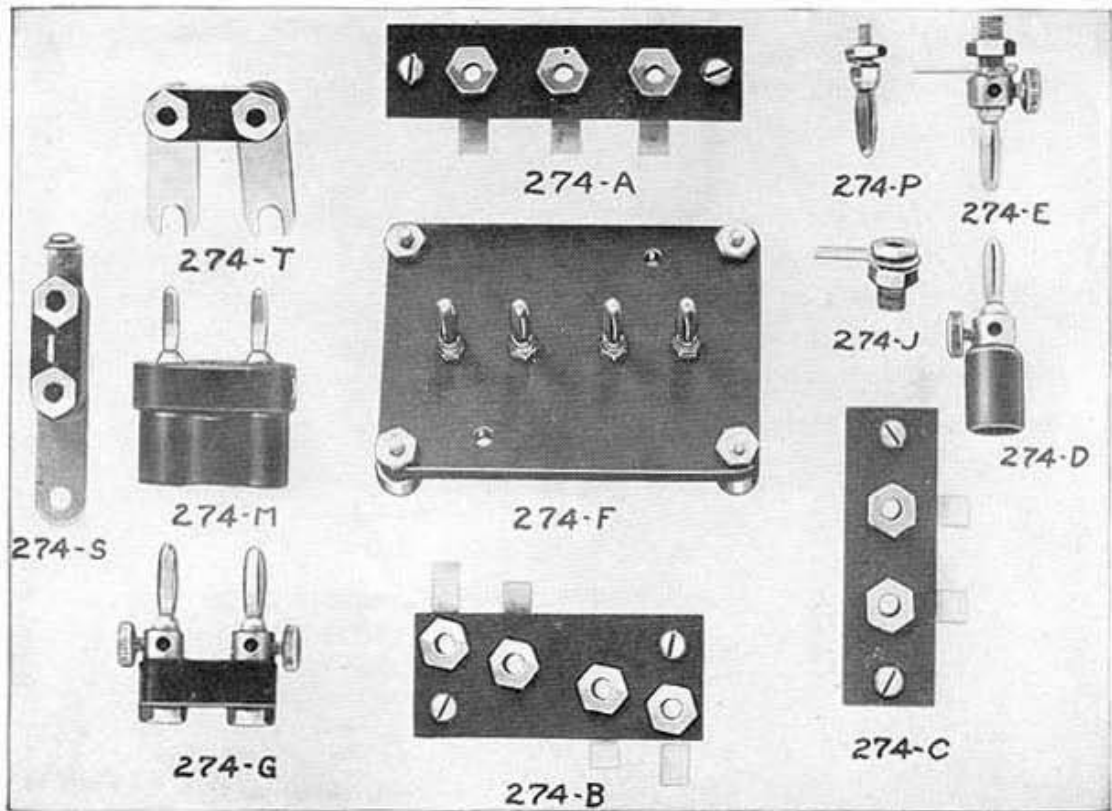

The experimenter will find the various items listed under the Type 274 group convenient for experimental work. This group consists of multi-connector plugs, jacks, plugs, transformer mounting bases and coil mounting bases. The various parts of this group will be found handy in comparing different methods of coupling either at radio or audio frequencies, and for interconnecting apparatus.

Type	Description	Price
274-A	3-Jack Base	\$.60
274-B	4-Jack Base65
274-C	2-Jack Base50
274-D	Single Insulated Plug25
274-E	Single Plug20
274-F	4-Plug Mounting Base75
274-G	Open Double Plug50
274-J	Jack05
274-M	Insulated Double Plug40
274-P	Plug06
274-R	4-Gang Plug50
274-S	Short-Circuit Jack50
274-T	Double Adjustable Jack50

INDEX

INSTRUMENT	TYPE NUMBER	PAGE
Amateur-Band Condenser	557	16
Amateur-Band Frequency Meter	558	79
Amateur Wavemeter	358	78
Amplifier Test Set	355	104
Amplifier Transformers	285	117
Amplifier Transformers	585	116
Artificial-Cable Boxes	321	114
Attenuation Networks	249	21
Attenuation Networks	329	21
Audibility Meter	164	26
Audio Oscillator	213	82
Beat-Frequency Oscillator	413	88
Binding Posts		135
Bridges		41-62
Capacity Bridge	216	48
Capacity Bridge	383	50
Capacity Meter	240	53
Decade Bridge	193	44
Mutual-Conductance Meter	443	60
Vacuum-Tube Bridge	361-B	56
Broadcast Wavemeter and Filter	247-W	81
Capacity Bridge	216	48
Capacity Bridge	383	50
Capacity Meter	240	53
Center Tap Resistance Unit	439	34
Center Tap Resistance Unit (Adjustable)	437	34
Coils	277	39
Condensers		5-16
Amateur-Band Condenser	557	16
Decade Condensers	219	5
Laboratory Condensers	239	12
Micro-Condensers	368	16
Precision Condenser	222	7
Tuning Condensers	247	14
Tuning Condensers	334	15
Tuning Condensers	374	15
Variable Air Condensers	246	10
Coupling and Tuning Coils	277	39
Coupling Impedance	369	40
Decade Bridge	193	44
Decade Condensers	219	5
Decade Resistances	102	18
Dials		131
Double-Impedance Coupler	373	118
Double String Holder	338-D	112
Filter Choke	366	40
Filter Sections	330	102
Five-Meter Wavemeter	458	80
Frequency Standards		63-81
Amateur-Band Frequency Meter	558	79
Amateur Wavemeter	358	78
Broadcast Wavemeter and Filter	247-W	81
Direct-Reading Wavemeter	174	73
Five-Meter Wavemeter	458	80

INDEX

INSTRUMENT	TYPE NUMBER	PAGE
Frequency Standard—continued		
Magnetostriction Oscillator (Single)	389	67
Magnetostriction Oscillator (Twin)	489	67
Piezo-Electric Oscillator	275	65
Piezo-Electric Oscillator (Station)	375	65
Precision Wavemeter	224	71
Quartz Plates	276	67
Quartz Plates	376	66
Station Frequency Meter	532	76
Galvanometer, Pointer	189	97
Galvanometer Shunt	229	27
Hot-Wire Meter	127	98
Hot-Wire Meter	170	98
Inductances		36-40
Coupling Impedance	369	40
Filter Choke	366	40
Inductance Standards	106	36
Radio-Frequency Chokes	379	39
Tuning and Coupling Coils	277	39
Variocoupler	268	38
Variometer (Laboratory)	107	37
Variometer	269	38
Inductance Standards	106	36
Insulator (Strain)	280	130
Insulator (Wall)	260	131
Jacks	274	135
Laboratory Condensers	239	12
Line-Amplifier Transformers	284	124
Low-Frequency Oscillator	377	85
Low-Voltage Transformer	440-A	128
Magnetostriction Oscillator (Single)	389	67
Magnetostriction Oscillator (Twin)	489	67
Meters		95-101
Audibility Meter	164	26
Direct-Reading Ohmmeter	287	101
Hot-Wire Meter	127	98
Hot-Wire Meter	170	98
Pointer Galvanometer	189	97
Thermionic Voltmeter	426-A	95
Micro-Condenser	368	16
Microphone-to-Grid Transformer (Single Button)	585-M	123
Microphone-to-Grid Transformer (Double Button)	585-M2	123
Miscellaneous Parts		134-136
Mutual-Conductance Meter	443	60
Ohmmeter, Direct-Reading	287	101
Oscillators		82-94
(See also Frequency Standards)		
Audio Oscillator	213	82
Beat-Frequency Oscillator	413	88
Low-Frequency Oscillator	377	85
Piezo-Electric Oscillator	275	65
Piezo-Electric Oscillator (Station)	375	65
Radio-Frequency Oscillator	384	90
Standard-Signal Generator	403	92
Oscillograph, String	338	107
Output Transformer	367	122
Output Transformer	585-O	121
Phantom Antenna Resistors	125	30

INDEX

INSTRUMENT	TYPE NUMBER	PAGE
Piezo-Electric Oscillator	275	65
Piezo-Electric Oscillator (Station)	375	65
Plate-Supply and Grid-Bias Unit	445	128
Plate-Supply Transformer	365	128
Plate-Supply Transformer	565	127
Plugs	274	135
Pointer Galvanometer	189	97
Potentiometer	371	31
Potentiometer	410	32
Potentiometer	301	33
Potentiometer	214	33
Precision Condenser	222	7
Precision Wavemeter	224	71
Push-Pull Amplifier	441	119
Push-Pull Amplifier Transformers	541	119
Quartz Plates	276	67
Quartz Plates	376	66
Radio-Frequency Chokes	379	39
Radio-Frequency Oscillator	384	90
Ratio Arm Box	210	43
Rectifier Filter	527-A	130
Resistance Devices		17-35
Audibility Meter	164	26
Attenuation Networks	249	21
Attenuation Networks	329	21
Center Tap Resistance Unit	439	34
Center Tap Resistance Unit (Adjustable)	437	34
Decade Resistances	102	18
Galvanometer Shunt	229	27
Phantom Antenna Resistor	125	30
Potentiometer	371	31
Potentiometer	410	32
Potentiometer	301	33
Potentiometer	214	33
Resistance Standards	133	20
Rheostats	214	33
Rheostats	301	33
Rheostat	340	29
Rheostats	410	32
Voltage Divider	446	34
Resistance Standards	133	20
Rheostats	214	33
Rheostats	301	33
Rheostat	340	29
Rheostats	410	32
Sockets		132-134
Adapter	346	133
Socket	156	132
Socket	299	132
Socket	349	133
Socket	438	133
Socket Cushion	309	134
Speaker Filter	387-A	122
Speaker Filter	587-B	122
Standard-Signal Generator	403	92
Station Frequency Meter	532	76
String Holder, Double	338-D	112
String Oscillograph	338	107
Switches		137

INDEX

INSTRUMENT	TYPE NUMBER	PAGE
Synchronous Motor	411-A	112
Telephone Transformers	166	126
Thermionic Voltmeter	426-A	95
Transformers		116-127
Amplifier Transformers	285	117
Amplifier Transformers	585	116
Impedance-Adjusting Transformer	285-N	126
Line-Amplifier Transformers	284	124
Low-Voltage Transformer	440-A	128
Microphone-to-Grid Transformer (Single Button)	585-M	123
Microphone-to-Grid Transformer (Double Button)	585-M2	123
Output Transformer	367	122
Output Transformer	585-O	121
Plate-Supply Transformer	365	128
Plate-Supply Transformers	565	127
Push-Pull Amplifier Transformers	541	119
Telephone Transformers	166	126
Variable-Ratio Transformers	359	124
Tuning Condensers	247	14
Tuning Condensers	334	15
Tuning Condensers	374	15
Tuning and Coupling Coils	277	39
Vacuum-Tube Bridge	361-B	56
Variable Air Condensers	246	10
Variable-Ratio Transformers	359	124
Variocoupler	268	38
Variometer	269	38
Variometer (Laboratory)	107	37
Voltage Divider	446	34
Voltmeter, Thermionic	426-A	95
Wavemeters		63-81
(See also Frequency Standards)		
Amateur-Band Wavemeter	558	79
Amateur Wavemeter	358	78
Broadcast Wavemeter and Filter	247-W	81
Direct-Reading Wavemeter	174	73
Five-Meter Wavemeter	458	80
Precision Wavemeter	224	71
Station Frequency Meter	532	76

