



CATALOG I

SINCE 1915—Designers and
Manufacturers of Radio and
Electrical Measuring Equipment

STROBOSCOPES
VARIACS
SOUND-LEVEL METERS
VIBRATION METERS
IMPEDANCE BRIDGES
SIGNAL GENERATORS
OSCILLATORS
WAVE ANALYZERS
DISTORTION METERS
IMPEDANCE STANDARDS
VACUUM-TUBE VOLTMETERS
FREQUENCY STANDARDS
BROADCAST MONITORS
PARTS & ACCESSORIES

GENERAL RADIO

COMPANY · CAMBRIDGE, MASS. U.S.A.





QUICK INDEX

| | |
|--|-----|
| HOW TO ORDER | v |
| INDUSTRIAL INSTRUMENTS | 3 |
| RESISTORS | 25 |
| CAPACITORS | 43 |
| INDUCTORS | 57 |
| BRIDGES AND ACCESSORIES | 63 |
| AMPLIFIERS AND POWER SUPPLIES | 99 |
| OSCILLATORS AND STANDARD-SIGNAL GENERATORS | 109 |
| WAVEFORM-MEASURING INSTRUMENTS | 131 |
| METERS | 143 |
| FREQUENCY-MEASURING EQUIPMENT | 161 |
| PARTS AND ACCESSORIES | 199 |
| REACTANCE CHARTS | 213 |
| DECIBEL TABLES | 217 |
| INDEX BY TYPE NUMBER | 223 |
| INDEX BY TITLE | 225 |

We Sell Direct . . .

To develop the type of product manufactured by the General Radio Company requires a large staff of engineers, each a specialist in one or more phases of the work involved. One of the functions of this staff is to assist the customer in the selection of instruments in order that the correct equipment may be purchased with a minimum expenditure.

There has always been an intimate contact between our engineers and our customers. The technical nature and the manifold uses of our product make the maintenance of this contact essential. For this reason, the General Radio Company maintains no sales agencies in the United States, but distributes its products directly to the consumer on a net, no discount, basis.

In order that customers outside the United States may receive equivalent technical service, exclusive distributors have been appointed in many foreign countries, each capable of giving technical information regarding General Radio products. In all matters regarding General Radio apparatus the customer should communicate with the distributor from whom this catalog was received. Prices listed in the catalog are for domestic use only. Costs in foreign countries, where import duty and freight must be added, can be obtained from the distributors in those countries.

GENERAL RADIO COMPANY

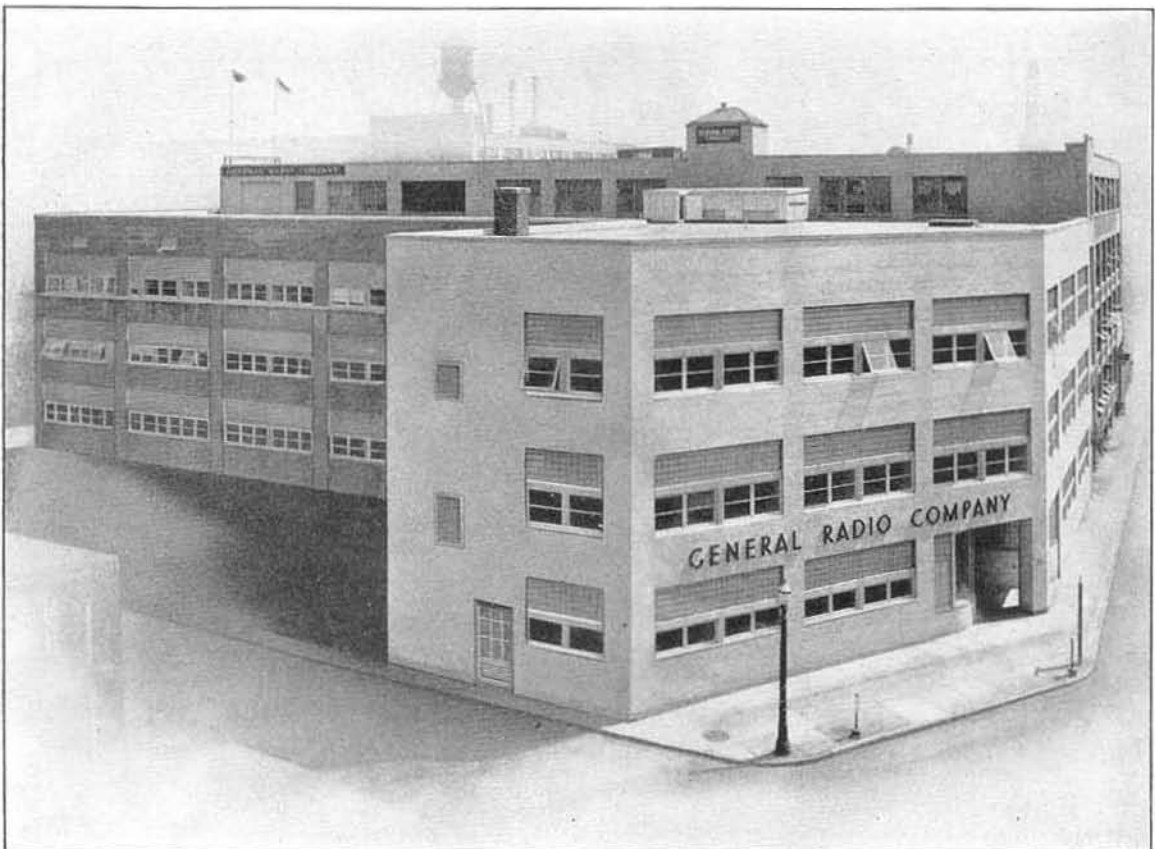

CATALOG L

1

9

4

8



GENERAL RADIO COMPANY

CAMBRIDGE 39, MASSACHUSETTS

NEW YORK

CHICAGO

LOS ANGELES

U. S. A.



SUGGESTIONS FOR ORDERING

ORDER BY TYPE NUMBER

Always order by catalog type number, and whenever possible mention name of item, ranges, or other significant specifications as protection against misunderstanding.

Be sure to include orders for any accessories desired or for calibrations which must be made before shipment. If minor modifications in the parts or instruments to be ordered would make the equipment more useful, our Sales Engineering Department would be glad to discuss the details.

TELEGRAPH AND CABLE ORDERS

We have direct telegraph printer connections with Western Union for the prompt handling of messages.

Use Bentley's code and the code words accompanying each catalog description. Our cable address is GENRADCO BOSTON.

SHIPPING INSTRUCTIONS

Unless specific instructions accompany the order, we shall use our best judgment as to the method of shipment. Repair parts or other items needed quickly can be shipped Air Express if requested. The following table shows approximate costs of this service in continental United States.

| <i>Air Miles</i> | <i>2 lbs.</i> | <i>5 lbs.</i> | <i>25 lbs.</i> | <i>40 lbs.</i> | <i>Over 40 lbs. Cents per lb.</i> |
|------------------|---------------|---------------|----------------|----------------|---------------------------------------|
| 149 | \$1.00 | \$1.00 | \$1.00 | \$1.23 | 3.07 |
| 349 | 1.02 | 1.18 | 2.30 | 3.68 | 9.21 |
| 549 | 1.07 | 1.42 | 3.84 | 6.14 | 15.35 |
| 1049 | 1.17 | 1.98 | 7.68 | 12.28 | 30.70 |
| 2349 | 1.45 | 3.53 | 17.65 | 28.24 | 70.61 |
| Over | | | | | |
| 2350 | 1.47 | 3.68 | 18.42 | 29.47 | 73.68 |

PACKING

There is no charge for our regular domestic or export packing and no charge for shipping containers or cases. Cases are not returnable.

TERMS

Net 30 days. All prices are F.O.B. Cambridge, Massachusetts. Unless credit has already been established, shipments are made C.O.D.

When full payment accompanies an order for equipment, except for repairs, we pay transportation charges to any point in the continental United States, except Alaska.

REMITTANCES

Should be made payable at par in Boston or New York funds.

PRICE CHANGES

All prices are subject to change without notice. Formal price quotations remain open for 30 days.

Prices shown will be increased by the amount of any applicable sales, use, excise, or similar taxes that are now in effect or that may hereafter be imposed by Federal, State, or local governments.

FOREIGN SALES

We are represented in principal countries abroad by resident distributors, who are in close touch with the factory and who have available the latest technical and commercial information about our products. As conditions permit, some General Radio representatives will carry stocks of the more popular items.

All prices shown in this catalog are net, f.o.b. the factory, for sales within the United States. Prices abroad, while based upon the same price list, will be somewhat higher because of customs duties, transportation charges, insurance, etc. Our representatives will welcome inquiries from customers in their territories concerning delivered prices and any other sales, service, or engineering matters.

See page 227 for list of representatives.



SUGGESTIONS FOR ORDERING

SPECIFICATION CHANGES

We reserve the right to discontinue instruments without notice, and to change specifications at any time without incurring any obligation to incorporate new features in instruments previously sold.

WARRANTY

We warrant each new instrument manufactured and/or sold by us to be free from defects in material and workmanship; our obligation under this warranty being limited to repairing or replacing any instrument or part thereof, except tubes and batteries, which shall, within one year after shipment to the original purchaser, prove after our examination to be thus defective.

REPAIR PARTS

When ordering repair parts, be sure to describe carefully the parts required, also referring to the symbol numbers and description from the parts list, and give the type number and serial number from the panel of the instrument.

SHIPMENTS TO GENERAL RADIO

When returning instruments for repair, recalibration, or for any other reason, please ask our Service Department for Return Material Tag and shipping instructions. Please state type number and serial number of instrument and date of purchase.

DOMESTIC SALES AGENCIES

Because of the Company's direct sales policy no general sales agencies are appointed. Complete stocks are carried only

at the factory warehouse. A partial stock is maintained at Los Angeles.

BRANCH ENGINEERING OFFICES

Engineering offices are maintained in the following cities:

New York 6: 90 West Street
Telephone WOrth 2-5837

Chicago 5: 920 South Michigan Avenue
Telephone WABash 3820

Los Angeles 38: 950 North Highland Avenue
Telephone HOLlywood 6201

Customers in or near these cities can quickly and conveniently obtain information about our products from these offices. In charge at each office is a competent, factory-trained engineer who will have all available technical and commercial data.

Although our domestic sales are made on a direct-to-the-consumer basis, we have arranged with numerous foreign distributors for the sale and servicing of our products outside of the United States. (See page 227.)

OTHER GENERAL RADIO PUBLICATIONS

In addition to this catalog we publish a number of bulletins of interest to technical and professional workers in specialized fields, and a monthly magazine, the *General Radio Experimenter*, for free distribution among interested persons. The *Experimenter* contains technical and semi-technical engineering articles which are contributed, for the most part, by our engineering staff. To be placed on the mailing list, merely fill in, clip, and mail the coupon below; or supply ALL of the information requested.

TO: General Radio EXPERIMENTER, 275 Massachusetts Ave., Cambridge 39, Mass.

Enter my COMPLIMENTARY subscription to the G-R EXPERIMENTER.

Name (print).....

Company Name.....

Company Address.....

Street

City and Zone No.

State

Type of Business..... Your Title.....

PATENTS

Many of our products are manufactured and sold under United States Letters Patent owned by the General Radio Company or under license grants from other companies. To simplify the listing of these patents they are given here in a single list and referred to at each instrument only by appropriate reference number.

1. Certain vacuum-tube amplifier devices, electric wave filters, vacuum-tube oscillators, and sound-level meters are licensed by Western Electric Company, Inc., under all United States Letters Patent owned or controlled by American Telephone and Telegraph Company, or Western Electric Company, Inc., and any or all other United States patents with respect to which Western Electric Company, Inc., has the right to grant a license, solely for utilization in research, investigation, measurement, testing, instruction, and development work in pure and applied science, including engineering and industrial fields.

2. Patent 1,871,886.
3. Patent 2,294,941.
4. Patent applied for.
5. Patent 1,901,343.
6. Patent 1,901,344.
7. Patent 1,944,315.
8. Patent 1,967,185.
9. Patent 2,173,427.
10. Patent 2,367,681.

11. Patent 2,009,013.
(also British Patent 439,567).
12. Licensed under all patents and patent applications of Dr. G. W. Pierce pertaining to piezo-electric crystals and their associated circuits.
13. Patent 2,069,934.
14. Patent 1,943,302.
15. Licensed under designs, patents and patent applications of Edgerton, Germeshausen and Grier.
16. Patent 2,376,394.
17. Patents 142,777 and 143,807.
18. Patent 1,983,447.
19. Patent 1,967,184.
20. Patent 2,012,497.
21. Patent 2,012,291.
22. Patent 1,999,869.
23. Patent 1,790,153 and other patents, covering electrical discharge devices and circuits with which said devices may be used, owned by the General Electric Company or under which it may grant licenses.
24. Patent 2,173,426.
25. Patent 2,298,177.
26. Patent 2,362,503.
27. Patent 2,029,358.
28. Patent 2,354,718.
29. Patent 2,025,775.
30. Patent 2,374,248.
31. Patent 2,125,816.

VISIT OUR LABORATORIES AND FACTORY

We cordially invite you to visit our engineering laboratories and factory the next time that you are in the vicinity of Cambridge.

Our plant is located in Cambridge (across the Charles River from Boston) at 275 Massachusetts Avenue. This is half way between the Massachusetts Institute of Technology and Central Square, Cambridge.

The accompanying map and the directions below give details for reaching the plant by public transportation or automobile.

HOURS FOR VISITORS: 10:00 A.M. to 4:00 P.M. every day except Saturdays, Sundays, and holidays.

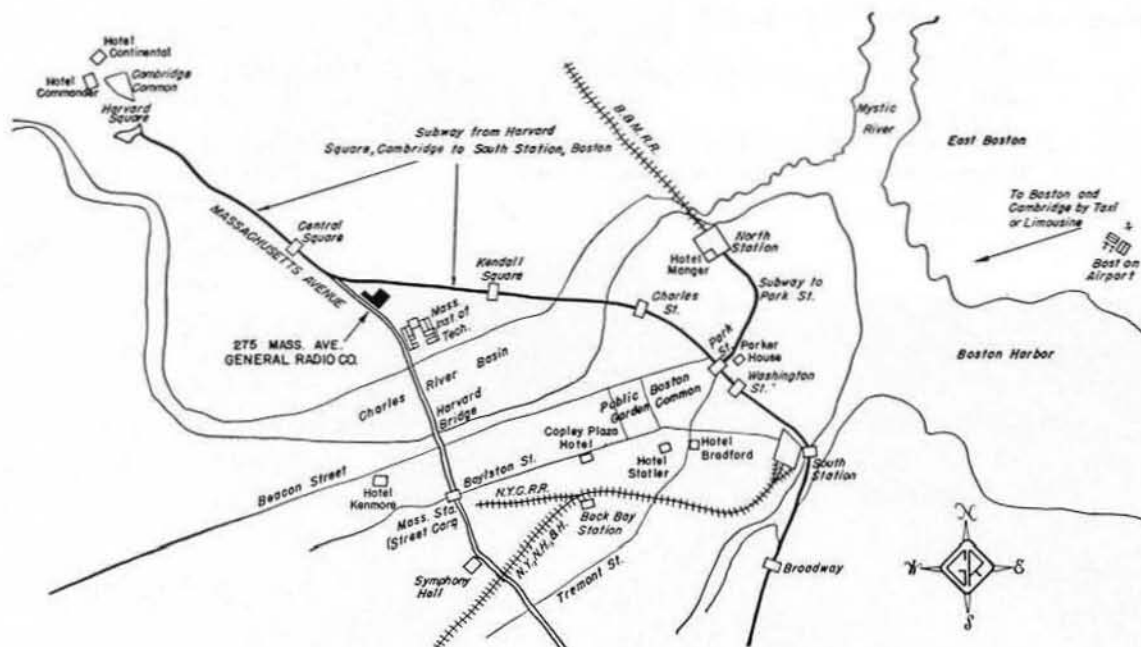

HOW TO REACH GENERAL RADIO COMPANY

BY PUBLIC TRANSPORTATION

From Central Square, Cambridge: Walk down Massachusetts Avenue about six blocks to "275" or take any Boston-bound surface car or bus on Massachusetts Avenue and get off at Windsor Street.

From South Station, Boston: Take a subway train for Cambridge and get off at the fifth stop, which is Central Square. Then follow preceding directions to 275 Massachusetts Avenue.

From North Station, Boston: Take a street car to the Park Street Subway Station and

change there to a Cambridge subway train on the lower level. Get off at Central Square, which is the third stop. See above.

From Massachusetts Station, Boston (Massachusetts Avenue and Boylston Street): Take a street car or bus marked "Harvard." After crossing the Charles River into Cambridge, get off at Windsor Street almost directly in front of General Radio.

BY AUTOMOBILE

Memorial Drive in Cambridge (Highway Routes U. S. 1 and Mass. 2, 28, and 38) runs

along the Charles River and intersects Massachusetts Avenue (underpass) at the Massachusetts Institute of Technology. General Radio is on Massachusetts Avenue one-third of a mile from this intersection.

Harvard Bridge crosses the Charles River

and connects Massachusetts Avenue in Boston and in Cambridge. From the Boston side of the river, turn into Massachusetts Avenue (from Highway Routes U. S. 20 and Mass. 16, 138) and proceed over Harvard Bridge into Cambridge.

WHEN TELEPHONING you may find the following list of departments and individuals of value in eliminating unnecessary delays before obtaining the information you desire. Our office telephone number is TRowbridge 6-4400.

| | |
|--|--|
| Delivery Information on Orders Already Placed (catalog items only) | Commercial Dept. H. P. HOKANSON |
| Price and Delivery Information on Equipment Not Yet Ordered; Technical Information on Uses of Equipment | Sales Engineering Dept. M. T. SMITH W. R. SAYLOR F. D. LEWIS S. W. DeBLOIS M. A. GILMAN |
| Service and Maintenance Information | Service Dept. R. G. ALEXANDER H. H. DAWES |
| Repair and Return of Equipment | Service Dept. F. W. SELLER |
| Repair and Replacement Parts — Price and Delivery Information | Service Dept. P. G. RICHMOND |

| Branch Engineering Offices | Telephone Number | Engineer in Charge |
|-----------------------------|------------------|--------------------|
| New York | WOrth 2-5837 | I. G. EASTON |
| Chicago | WABash 3820 | K. ADAMS |
| Pacific Coast (Los Angeles) | HOLlywood 6201 | F. IRELAND |

INDUSTRIAL INSTRUMENTS



STROBOSCOPES

SOUND AND
VIBRATION
MEASURING
EQUIPMENT

VARIACS

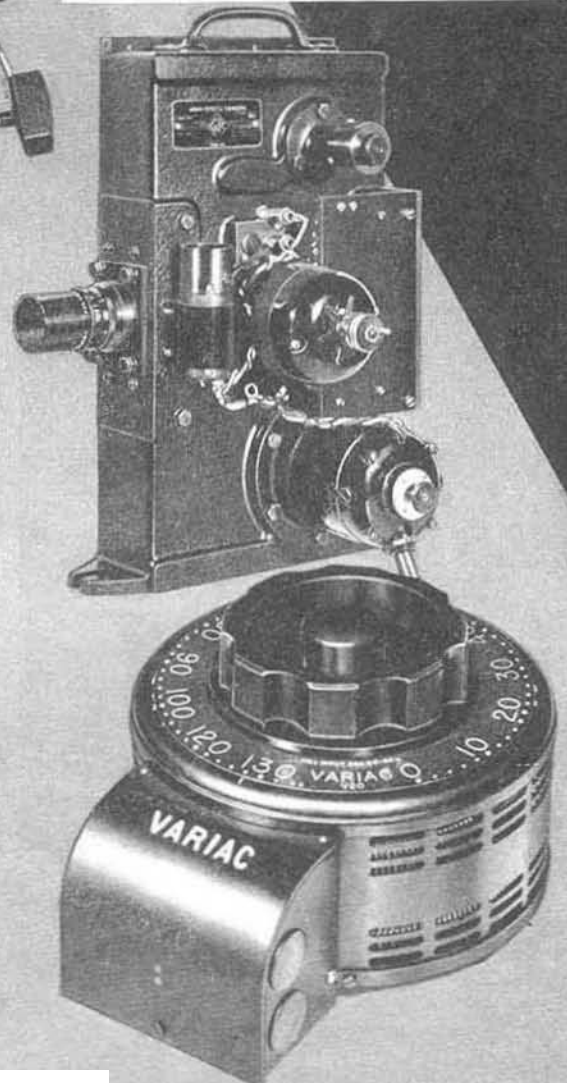
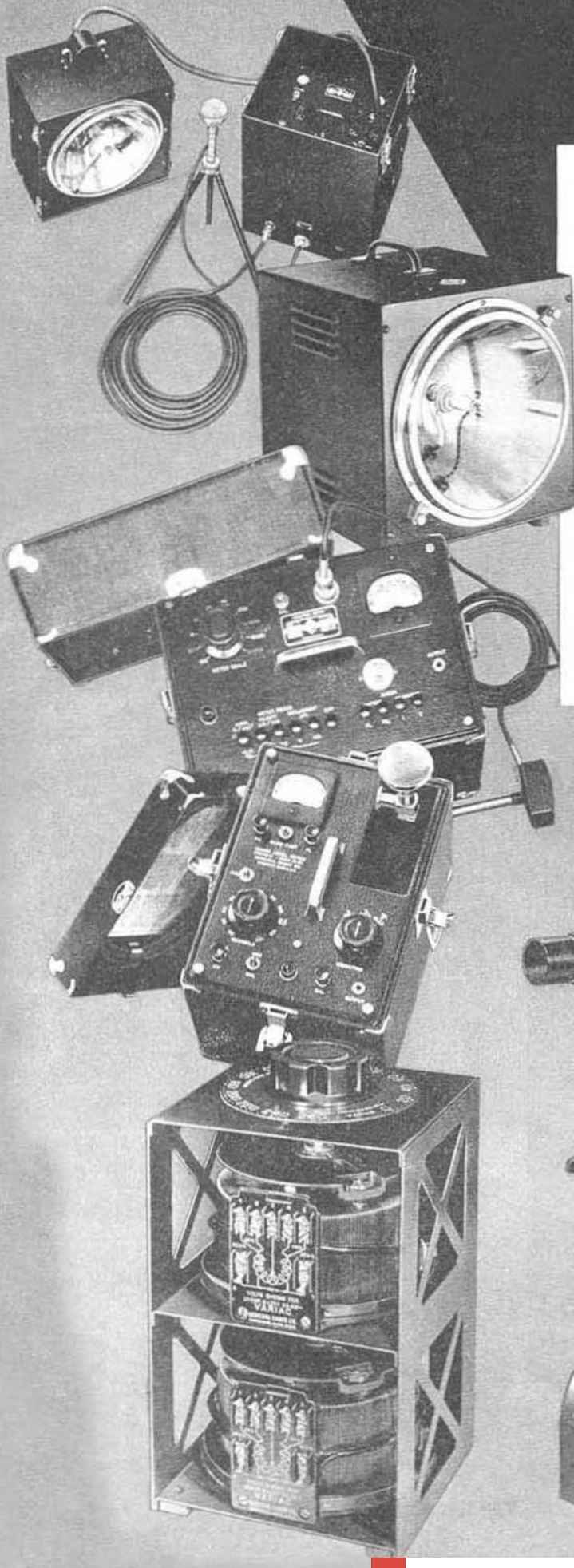

STROBOSCOPES

THE STROBOSCOPE permits rotating or reciprocating objects to be viewed intermittently and produces the optical effect of slowing down or stopping motion. For instance, an electric fan revolving at 1800 rpm will apparently be standing still if viewed under a light that flashes uniformly 1800 times per minute. At 1799 flashes per minute, the fan will appear to revolve at 1 rpm, and at 1801 flashes, it will rotate backward at 1 rpm. Because the eye retains images for an appreciable fraction of a second, no flicker is seen except at very low speeds. The apparent slow motion is an exact replica of the original higher-speed motion, so that the motion of a high-speed machine can be analyzed with the stroboscope under normal operating conditions.

The stationary image that is seen when the flash and rotational speeds are equal makes possible very precise speed settings, and when the flash rate control is calibrated in rpm, as in the STROBOTAC, the stroboscope can be used as a tachometer.

When the TYPE 549-C Contactor is used to flash a stroboscope, the position of the flash within a single cycle of motion can be adjusted. With the TYPE 549-P2 Hand Contactor, the flash can be controlled by the position of a camshaft or crankshaft on the machine under observation.

For photography of objects moving at high speeds, General Radio stroboscopes provide a means of taking both still and motion pictures.

For ultra-high-speed single-flash work, the MICROFLASH (page 8) is recommended, which has a flash duration of only about two millionths of a second. For slower speed work, 15 to 50 millionths of a second, if a limited area is to be photographed, the STROBOLUX can be used.

For photographing large areas, or for ultra-high-speed motion pictures, the TYPE 1533-A High-Speed Motion-Picture Assembly should be used.

Uses of the stroboscope are discussed in more detail in the booklet *Eyes for Industry*, a copy of which will be sent upon request.

TYPE 631-B STROBOTAC*

USES: The Strobotac is used for measuring the speed of rotating, reciprocating, or vibrating mechanisms and for observing their operation in slow motion. In the design and testing of machines and high-speed mechanisms, the



Strobotac is invaluable. The operation of motors, fans, pulleys, gears, cams, and other machine elements can be examined in slow motion. Speed measurements for overload and underload tests can be made. It is ideally suited for rapidly adjusting the speeds of a number of machines intended to operate at the same speed, as, for instance, textile spindles. In production testing, it provides a means of rapidly aligning mechanisms that operate under close tolerances. It is approved for use in checking the calibration of aircraft tachometers.

DESCRIPTION: The Strobotac is a small, portable stroboscope calibrated to read speed directly in revolutions per minute. The light source is a Strobotron lamp mounted in a parabolic reflector. The frequency of a self-contained electronic pulse generator determines the flashing speed, which can be adjusted, by means of a direct-reading dial, to any value between 600 rpm and 14,400 rpm. If desired, the speed can be controlled by an external contactor, by the a-c line frequency, or by an oscillator.

The Strobotron is designed to give an extremely short flash, and hence sharp images are obtained even at speeds up to several times the scale values.

*Trade Mark Registered U. S. Patent Office.



TYPE 631-B Strobotac with TYPE 648-A Strobulox.

Speeds outside the scale range of the instrument can be measured by using multiples of the flashing speed. The upper limit is not sharply defined, but, in general, speeds up to about 100,000 rpm can be measured. Speeds below 600 rpm can also be measured, but the use of the Strobotac for this range is not recommended, because of flicker caused by the inability of the eye to retain successive images for a sufficiently long period of time to give the illusion of continuous motion.

FEATURES: ▶ No contact with the mechanism under measurement is required, and hence no power is absorbed when the Strobotac is used for speed measurement.

- ▶ The accuracy of measurement is within $\pm 1\%$ of indicated speed, when the scale is standardized from a frequency-controlled power line.
- ▶ The Strobotac can be used in places inaccessible to other types of tachometers; it is necessary only to direct the stroboscopic light on the element under measurement.
- ▶ A slow-motion drive facilitates precise speed settings, and the speed scale is easily read from the drum-type dial when the Strobotac is held in the position of normal use.

When a larger area is to be illuminated, the Strobulox can be used to control the flashing speed of the TYPE 648-A Strobulox described on page 4.

SPECIFICATIONS

Range: The fundamental range of flashing speed is from 600 to 14,400 per minute. The speed is read directly from a dial calibrated in rpm. By using multiples of the flashing speed, the range of measurement can be extended up to about 100,000 rpm, and, by multiple images, speeds somewhat below 600 rpm can be measured.

Accuracy: $\pm 1\%$ of the dial reading above 900 rpm when the Strobotac is standardized in terms of a frequency-controlled power line. Controls for this standardization adjustment are provided. When an external flashing means is used, the accuracy is that of the flashing source.

Duration of Flash: Between 5 and 10 microseconds.

Power Supply: 105 to 125 volts, 60 cycles. Prices for operation from lines of other voltages and frequencies will be quoted on request.

Power Input: 35 watts.

Vacuum Tubes: One TYPE 631-P1 Strobotron, one 6X5-GT/G and one 6N7-GT/G are required. A complete set of tubes is furnished with the instrument.

Accessories Supplied: Seven-foot line connector cord and plug to fit contactor jack.

Mounting: Metal cabinet with carrying handle.

Dimensions: $7\frac{1}{2} \times 8\frac{3}{4} \times 9\frac{7}{8}$ inches, over-all.

Net Weight: $9\frac{1}{2}$ pounds.

| Type | | Code Word | Price |
|--------|----------------------------------|-----------|----------|
| 631-B | Strobotac | BRAVO | \$125.00 |
| 631-P1 | Replacement Strobotron | SENNA | 5.00 |

PATENT NOTICE. See Note 15, page vi.

TYPE 648-A STROBOLUX*



TYPE 648-A Strobolux.

USES: The TYPE 648-A Strobolux extends the usefulness of the Strobotac to applications requiring considerably more light than the Strobotron lamp is capable of supplying. Specifically, it should be used where larger areas are to be illuminated or where greater light intensity is required.

Although not as fast as the Microflash, the Strobolux has been used in experimental work

for making high-speed single-flash photographic records of limited areas. It has also found some application as a light source in conjunction with a continuous-film camera.

DESCRIPTION: TYPE 648-A Strobolux consists of a power supply and lamp, capable of producing brilliant light flashes at speeds up to 6000 per minute. The flashing source is a TYPE 631-B Strobotac and consequently can be controlled by (1) the self-contained pulse generator in the Strobotac, (2) the a-c line, (3) an external contactor (TYPE 549), or (4) an external oscillator, preferably one which can supply square wave pulses.

The lamp, filled with a rare gas, furnishes about one hundred times as much light as that of the Strobotac.

The entire assembly is housed in a metal cabinet with the lamp and its 9-inch reflector on one side. The lamp housing is removable from the case and is furnished with a 10-foot extension cable.

FEATURES: The combination of the TYPE 631-B Strobotac and TYPE 648-A Strobolux has all the advantages of the Strobotac itself plus the feature of high illumination. No appreciable duplication of facilities is involved, so that the purchase of the TYPE 648-A Strobolux is an economical solution to problems requiring greater illumination than is provided by the Strobotac.

SPECIFICATIONS

Range: Up to 100 flashes per second (6000 per minute). Single flashes for photography can also be obtained.

Duration of Flash: Between 15 and 50 microseconds, depending upon flashing speed and upon the setting of the SPEEDS range switch. The shorter flash is obtained at the higher speeds.

Accuracy: The accuracy is that of the source controlling the flashing speed. (See specifications for TYPE 631-B Strobotac, page 3.)

Power Supply: 105 to 125 (or 210 to 250) volts, 50 to 60 cycles.

Power Input: 125 watts, maximum.

Vacuum Tubes: One 5Z3 Rectifier and one TYPE 648-P1 Lamp, both of which are furnished with the instrument.

Mounting: The complete assembly is housed in a sheet metal case. The lamp and its 9-inch reflector are mounted on one side, the power supply on the other. The removable lamp assembly is provided with a 3/4 x 20 tapped hole for tripod mounting.

Accessories Required: A Strobotac is necessary to operate the Strobolux.

Accessories Supplied: A power cable, a cable for connection to the Strobotac, an extension cable for the lamp.

Dimensions: 13 3/8 x 11 3/8 x 13 1/2 inches, over-all.
Net Weight: 31 3/4 pounds.

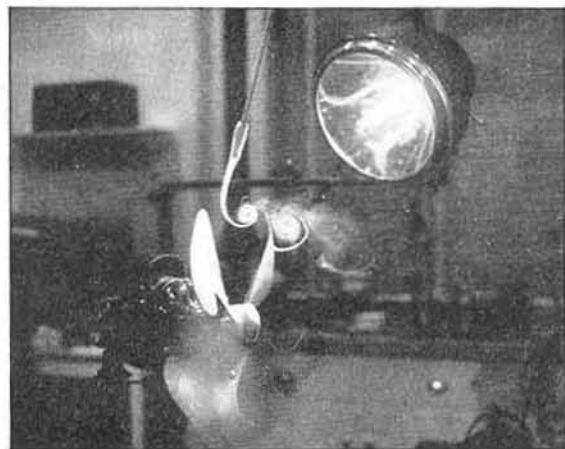

Air currents caused by a fan are shown with the aid of the Strobolux.

| Type | | Code Word | Price |
|--------|------------------------|-----------|----------|
| 648-A | Strobolux | SCALY | \$205.00 |
| 648-P1 | Replacement Lamp | SURLY | 17.50 |

PATENT NOTICE. See Note 15, page vi.
*Trade Mark Registered U. S. Patent Office.



TYPE 549-C SYNCHRONOUS-MOTOR CONTACTOR TYPE 549-P2 HAND CONTACTOR

USES: These contactors are intended for use with General Radio stroboscopes as sources of accurately timed controls for flashing. A plug-in cable is provided for connection between the contactor head and the Strobotac.

DESCRIPTION: The synchronous-motor contactor, TYPE 549-C, when driven from a 115-volt, 60-cycle line, is capable of flashing a TYPE 631-B Strobotac at any rate between 150 and 3600 flashes per minute. The contactor is driven by an 1800-rpm self-starting synchronous motor. Flashing rate adjustment is made by turning the fluted knob, which changes the ratio of the friction-drive mechanism. A calibrated scale gives the flashing rate in flashes per minute. Phase can be adjusted independently at the contactor head. Two ranges are provided, one covering speeds from 150 to 1300 rpm, the other from 700 to 3600 rpm. These are fundamental ranges; speeds which are multiples of them can, of course, be measured. Two discs and two scales are provided, and the change from one range to the other can be accomplished in a few minutes.

The contactor head can be removed and used independently as a hand contactor. A rubber driving tip is provided for this purpose.

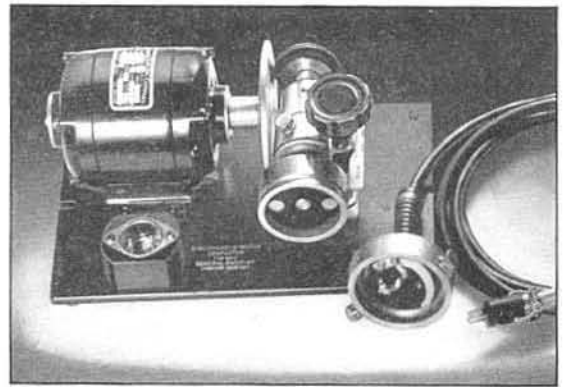

TYPE 549-C Synchronous-Motor-Driven Contactor.

The uncalibrated head, fitted with rubber tip so that it can be driven from a rotating shaft, is available separately as the TYPE 549-P2 Hand Contactor.

FEATURES: Accurately timed flashing rates as low as 150 per minute can be obtained. The phase of the flash, i.e., its time in the flashing cycle, can be adjusted. This makes it possible to arrest the motion of a mechanism at any point in its cycle of operation. In many stroboscopic investigations this feature is valuable.

SPECIFICATIONS

TYPE 549-C

Range of Flashing Speeds: 150 to 3600 flashes per minute in two ranges, 150 to 1300 and 700 to 3600.

Controls: One knob for adjusting speed and the movable contactor head for adjusting phase. Each is provided with

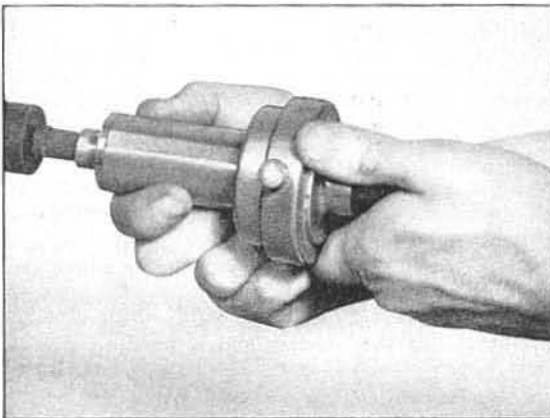

TYPE 549-P2 Hand Contactor.

a locking arrangement for holding it firmly in the desired position.

Accuracy: The accuracy is determined by the frequency stability of the power line and the amount of wear of the rubber rim on the driven wheels. When the wheels and scales are set correctly, the error will increase as either scale end is approached, and may be considered to be not greater than ± 50 rpm on the low, and ± 100 rpm on the high scales.

Power Supply: 105 to 125 volts, 60 cycles.

Power Input: 35 watts.

Accessories Supplied: Power cable; rubber driving tip for use as a hand contactor.

Mounting: Motor and contactor are mounted on an aluminum base. Changing from the high to the low speed range, and vice versa, necessitates changing the size and position of the driven disc. Two sets of mounting holes, two discs, and two scales are provided for this purpose.

Dimensions: (Length) $9\frac{3}{4}$ x (width) $6\frac{3}{4}$ (height) $4\frac{3}{8}$ inches, over-all.

Net Weight: $10\frac{1}{2}$ pounds.

TYPE 549-P2

Dimensions: (Length) 7 x (diameter) $3\frac{1}{4}$ inches, over-all.

Cord: Connecting cord is furnished.

Net Weight: $2\frac{5}{8}$ pounds.

| Type | | Code Word | Price |
|---------|-------------------------------------|-----------|----------|
| 549-C | Synchronous-Motor Contactor..... | MACAW | \$100.00 |
| 549-P2 | Hand Contactor..... | MADAM | 40.00 |
| 549-373 | Replacement Disc (150-1300 rpm).... | HYDRA | 9.00 |
| 549-371 | Replacement Disc (700-3600 rpm).... | HYMEN | 4.50 |

PATENT NOTICE. See Note 15, page vi.

TYPE 651-AG CAMERA

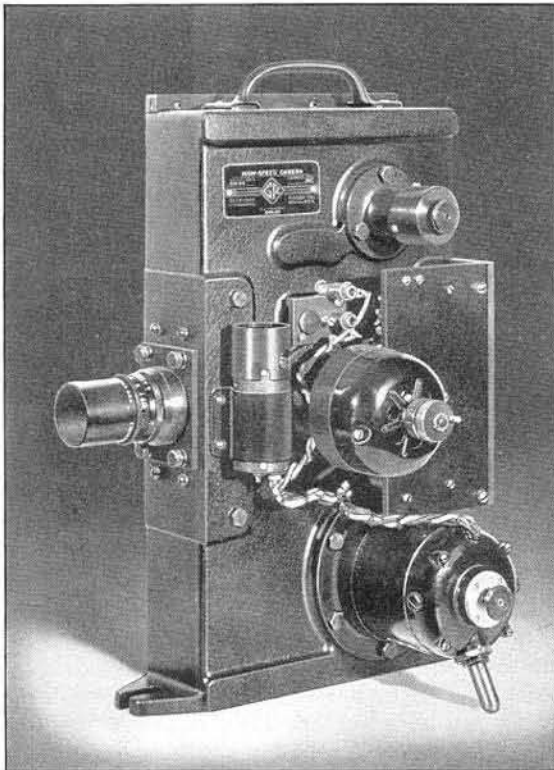

USES: The TYPE 651-AG Camera is intended for use in taking high-speed stroboscopic pictures at rates between about 500 and 1500 frames per second. These pictures are useful

for analyzing the operation of rapidly moving mechanisms, and can also be projected in "slow motion." Since the camera has no shutter, and the film is continuously in motion, the illumination must be provided by a high-speed, high-power stroboscope, such as the TYPE 621-M (see next page), which also includes the necessary switching controls. This camera can also be adapted for taking high-speed oscillograms in conjunction with a cathode-ray oscilloscope. When the camera is used with other light sources, which must also be of the "flashing" type, suitable control equipment must be devised.

DESCRIPTION: The camera is similar in general construction to the TYPE 651-AE Oscillograph Recorder (described on page 136), but only a single motor, which drives the lower or take-up reel, is used. A governor mounted on the sprocket shaft controls the speed of the motor to give a constant film speed. The commutator, which trips the stroboscope at single-frame intervals on the film, is made an integral part of the sprocket. The TYPE 651-P5 Lens which is recommended for use with this camera has an aperture of $f/1.5$, 2-inch focal length, and a focusing range of 8 to 100 inches. A spark coil, which can be excited from an external source such as the TYPE 631-B Strobotac, is provided on the camera to furnish timing marks on the film.

SPECIFICATIONS

Film: Any type of 35-mm film with standard perforations can be used. A high-speed-emulsion type is recommended.

Film-Speed Range: From about 35 to 100 feet per second adjustable by means of the governor. This range corresponds to about 500 to 1500 standard $\frac{3}{4}$ -inch frames per second.

Lens System: Lens must be purchased separately. The TYPE 651-P5, $f/1.5 \times 2''$ is recommended (see price list below). This lens is supplied complete with an iris diaphragm and focusing mount and is installed on the camera with a mounting plate.

Focusing: With TYPE 651-P5 Lens as supplied, the focusing range is 8 to 100 inches. Focusing is accomplished by viewing the image, on a translucent screen placed on the sprocket, through a telescope at the rear of the camera. Windows are provided in the sprocket for this purpose.

Reels: Specially made reels are supplied. It is important that these be used, since ordinary commercial reels do not operate satisfactorily at high film speeds. Capacity of reels, 100 feet.

Drive System: The film is driven by a 115-volt universal motor on the take-up reel. For high speeds, the

motor is driven by higher voltages, and 230 volts can be applied without damage for the short period that the camera operates.

Speed Control: The voltage applied to the motor must be adjustable, and a TYPE V-5H or V-5HMT Variac is recommended for this purpose. This Variac is supplied as part of the TYPE 621-M Power Stroboscope when that equipment is used with the camera. An adjustable electrical governor, which keeps the film at constant speed, is mounted on the sprocket shaft. Speed is changed by adjusting the governor and setting the Variac at approximately the correct voltage for the desired speed.

Starting: Full speed is attained in from 10 to 40 feet of film travel, depending upon the amount of film on the reel and the operating speed.

Commutator: The commutator is integral with the sprocket inside the housing, and is provided with a contact pressure adjustment.

Accessories Supplied: Power cable, cable for connecting to power stroboscope, spare reel, rewind adapters, and light-shield band for film reel.

Dimensions: (Height) $16\frac{1}{2} \times 11\frac{7}{8} \times 8$ inches, over-all.
Net Weight: $30\frac{3}{4}$ pounds.

| Type | | Code Word | Price |
|--------|-----------------------------------|-----------|----------|
| 651-AG | Camera | DIRGE | \$693.00 |
| 651-P5 | Lens $f/1.5 \times 2''$, mounted | DIARY | 165.00 |

PATENT NOTICE. See Note 15, page vi.



TYPE 1533 HIGH-SPEED MOTION-PICTURE ASSEMBLY

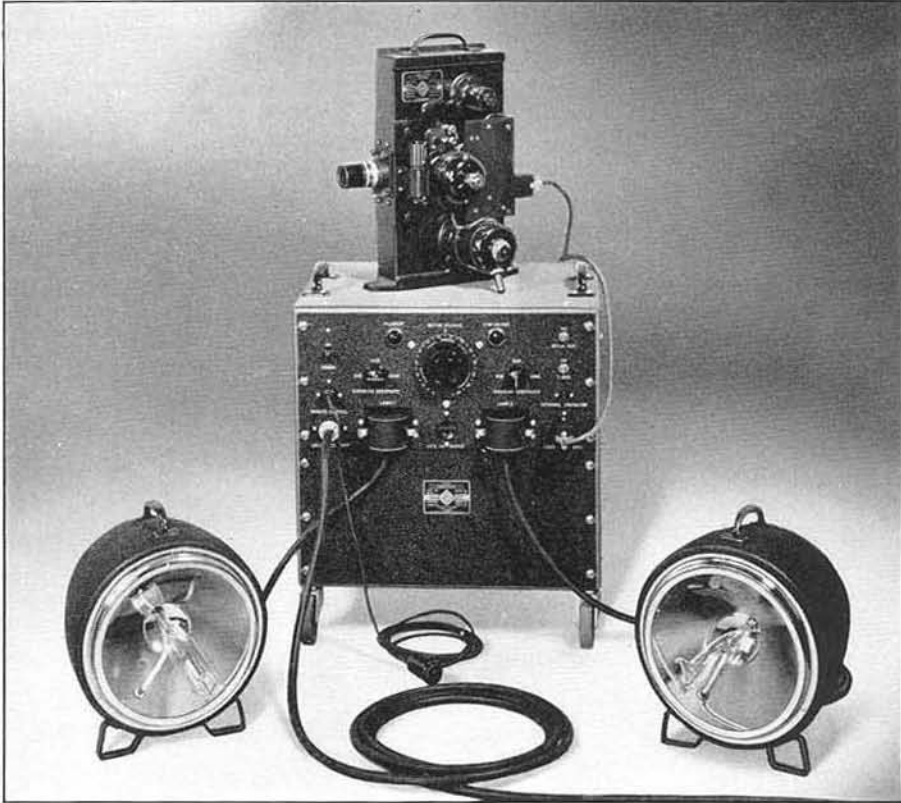

USES: This equipment consists of an ultra-high-speed light source and a continuous-film camera. With this combination, motion pictures of transient and non-repetitive phenomena can be taken at speeds up to 1500 frames per second. The film can be projected at normal speeds, for slow-motion studies, or can be analyzed, frame by frame, and the data plotted to provide the desired information. This high-speed motion-picture assembly has been successfully applied to the solution of a number of industrial and engineering problems, among them transient motions in automatic machinery, the mechanisms of chemical engineering processes, and cavitation of propellers under water. Single- and multiple-flash photographs on a single film are also possible with this equipment.

DESCRIPTION: The TYPE 1533-A High-Speed Motion-Picture Assembly comprises the TYPE 621-M Power Stroboscope and the TYPE 651-AG Camera (see preceding page).

The principal difference between the power stroboscope and smaller models lies mainly in the size of the power supply. Since the power demand of a stroboscope is proportional to light intensity and to flashing speed, the power input to this stroboscope is considerably

greater than that required for smaller instruments, and about 3 kilowatts is required when pictures are being taken.

The camera has no shutter, and the film is in continuous motion. Framing is accomplished by a commutator on the sprocket, which flashes the stroboscope at intervals of one frame. All controls for operating the camera and lamps are on the power supply panel. Two lamps are furnished to provide adequate illumination.

Since the heat dissipated in the lamps is considerable, the power stroboscope is not intended for continuous operation. A little over one second is required to expose a 100-foot roll of 35-mm film.

FEATURES: ▶ Motion pictures at speeds up to 1500 frames per second can be taken with this equipment.

▶ An exposure time per frame of approximately $1/100,000$ of a second is possible at all frame speeds.

▶ Camera film speeds up to 100 feet per second make possible the recording of extremely rapid transients when photographing high-intensity cathode-ray tubes having non-persistent screens.

STROBOSCOPES

SPECIFICATIONS

Flash Duration: About 10 microseconds.

Frame-Speed Range: Approximately 500 to 1500 frames per second, adjustable by means of the governor on the camera. For other camera details see page 6.

Power Input: Approximately 3 kilowatts.

Power Supply: 230 volts, 50 to 60 cycles, single phase.

Tubes: Four 866-A Rectifiers, two TYPE 621-P14 Flash Tubes, two TYPE 621-P15 Mercury Tubes, one 80 Rectifier, one TYPE 631-P1 Strobotron, and one FG-67 (G-E) Thyatron.

Mounting: The power stroboscope is housed in a metal

cabinet, with casters, and operating controls are on the front panel. Lamps and camera connect to the power supply by cables, as shown in the accompanying photograph.

Dimensions: Power Stroboscope, 24 x 20 x 26 inches over-all; Camera, see page 6.

Accessories Supplied: Power cable, all necessary control cables, contactor plug, spare pilot lamps, flash tubes and control tube, and all accessories normally supplied with TYPE 651-AG Camera.

Net Weight: 225 pounds.

| <i>Type</i> | | <i>Code Word</i> | <i>Price</i> |
|---------------|---|------------------|-------------------|
| 1533-A | High-Speed Motion-Picture Assembly | MANGY | \$3,400.00 |

PATENT NOTICE, See Notes 15, 23, page vi.

TYPE 1530-A MICROFLASH

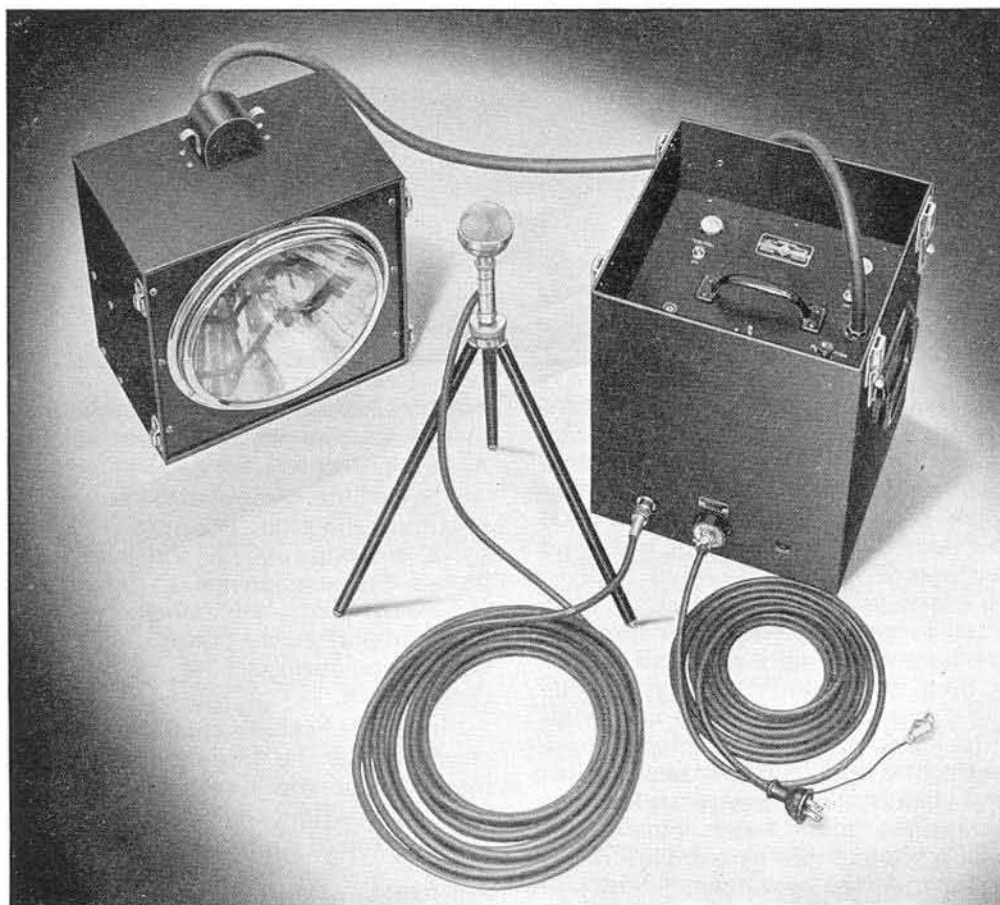

USES: The Microflash is a light source for single-flash, ultra-high-speed photography. It provides a high-intensity light flash whose duration is approximately 2 millionths of a second. Consequently, it is capable of arresting extremely rapid motion. Conventional camera equipment is quite satisfactory for use with the Microflash.

Photographs of objects moving at ex-

remely high speeds are possible with the Microflash, and it finds many applications in engineering and the physical sciences, particularly in such fields as ballistics, hydraulics, kinematics, and industrial chemistry.

Among these are studies of wear or abrasion, of turbulence in liquids, of fractures in solids, of mechanical distortion at high rotational speeds, and of the atomization of liquid fuels.

DESCRIPTION: The elements of the Microflash are a power supply, a gas-filled lamp, and a trigger circuit. A high-voltage transformer and rectifier, operating from the a-c power line, charge a capacitor across the lamp terminals. An electrical impulse, which may be derived in any one of several ways from the phenomenon to be photographed, ionizes the gas in the lamp, and the energy stored in the capacitor is dissipated in a discharge through the lamp, producing a short brilliant flash. A minimum of 10 seconds is required between flashes for the capacitor to become fully charged.

The trigger circuit includes an amplifier, so that the flash can be tripped with a conventional crystal microphone, if desired. The flash can also be triggered by a make or break contact.

FEATURES: The outstanding feature of the Microflash is its high-intensity, very short flash. During the flash, an object moving at 1000 feet per second would be displaced only about two hundredths of an inch. Consequently, sharp records can be obtained of bullets and other projectiles in flight.

(Right) The Microflash was used as the light source in taking this photograph of a 20-mm shell crashing through shatter-proof glass.



SPECIFICATIONS

Duration of Flash: Approximately 2 microseconds.

Guide Number: The so-called guide number (Distance in feet x aperture) for the Microflash is about 45 with moderately fast film, and with the subject several feet from the lamp.

Temperature and Humidity Effects: Temperature and humidity variations (32 to 100° F, 0 to 95% R.H.) have no appreciable effect upon the operation of the instrument.

Power Supply: 105 to 125 (or 210 to 250) volts, 50 to 60 cycles.

Power Input: 70 watts.

Tubes:

- 1 — 5U4-G
- 1 — 2V3-G
- 1 — TYPE 1530-P1 (General Radio)
- 1 — FG-17 (GE)
- 1 — 6AC7 (1852)

Accessories Supplied: Microphone with cable; tripod; all tubes; 2 spare flash lamps TYPE 1530-P1; plug for connection to contactor-trip jack; power cable.

Mounting: the power supply and trigger circuits are assembled in one metal case, the lamp in another. The two cases lock together for transportation, completely protecting the lamp and controls.

Dimensions: 24 1/8 x 13 1/4 x 11 3/4 inches, over-all.

Net Weight: 72 pounds.

(Right) View of the Microflash assembled for transportation

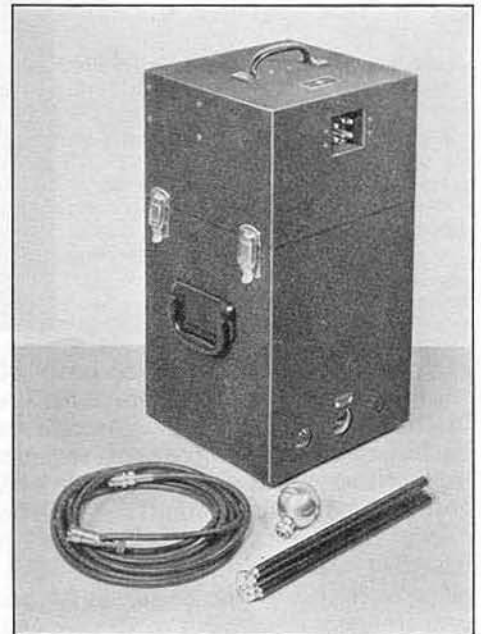

| Type | | Code Word | Price |
|---------|----------------------------------|-----------|-----------|
| 1530-A | Microflash | TAFFY | \$600.00* |
| 1530-P1 | Replacement Flash Lamp | TONIC | 22.00* |

*Plus current Federal tax on photographic equipment.
 PATENT NOTICE. See Notes 15, 23, page vi.

INSTRUMENTS FOR THE MEASUREMENT OF NOISE AND VIBRATION

GENERAL RADIO noise meters and vibration meters provide means of measuring objectively the noise and vibration generated in machines, appliances, and similar equipment. With the sound-level meter, noise levels can be measured, acceptance tests based on objective standards can be set up, and production line testing for noise can be easily and simply carried out. The sound analyzer permits an evaluation of the individual frequency components of the noise, which can be used to identify specific noise sources arising from faulty adjustment or manufacture. These instruments are equally useful in the laboratory and design department as aids to the testing and proving of experimental models.

The vibration meter and vibration analyzer measure solid-borne vibrations in the same way that the sound-measuring instruments measure air-borne vibrations.

Three types of response are provided: displacement; velocity; and acceleration; so that all the significant characteristics of the vibration can be measured. By means of the analyzer, single components can be selected and measured. Thus, vibrations characteristic of critical parts can be conveniently and quickly evaluated.

General Radio sound- and vibration-measuring instruments are more completely described in *The Noise Primer*, a copy of which will be mailed on request.

TYPE 759-B SOUND-LEVEL METER

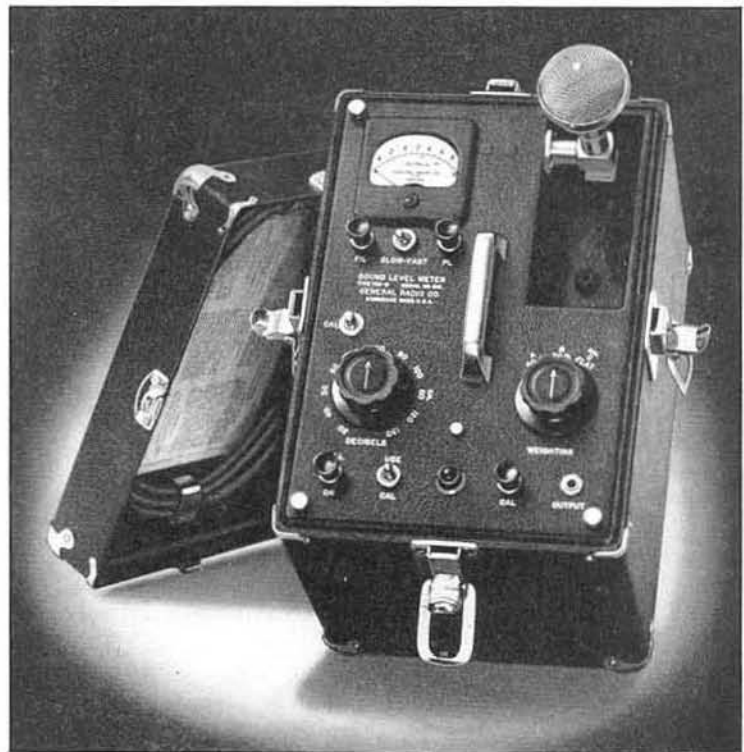

USES: The TYPE 759-B Sound-Level Meter is suitable for all types of commercial and industrial noise measurement. Manufacturers of machinery and appliances use it for measuring product noise both in the research laboratory and in production. Sound transmission and absorption and the acoustical properties of materials can also be measured with it. It meets equally well the requirements for noise measurement in surveys of the psychological and physiological effects of noise.

For the industrial plant, it provides a means of measuring product noise, setting up noise standards, accepting or rejecting products on the basis of noise tests, and, finally, analyzing and correcting trouble in the rejected units.

In this last use, as in many others, a frequency analysis of the noise is usually valuable. For this purpose, the TYPE 760-A Sound Analyzer (see page 13) has been specifically designed.

The usefulness of the sound-level meter may be extended to include vibration measurements by substituting a vibration pickup (see page 12) for the microphone. The low-frequency response of the sound-level meter is sufficiently good to permit vibration measurements at frequencies down to 20 cycles. Such measurements include the fundamental and harmonic frequency vibrations of machines rotating at 1200 rpm or higher, as well as many structural resonances.

For vibration measurements below 20 cycles, however, the TYPE 761-A Vibration Meter is recommended (see page 15).

DESCRIPTION: TYPE 759-B Sound-Level Meter is an accurate, portable, low priced meter for reading, in terms of a standard reference level, the sound level at its microphone.

The sound-level meter consists of a non-directional microphone, an amplifier, a calibrated attenuator, and an indicating meter. A functional diagram of the system is shown on page 12.

The complete instrument, including batteries, is mounted in an airplane-luggage type of case. An a-c power supply unit, TYPE 1261-A, is available and is interchangeable with batteries (see page 102).

FEATURES: ▶ The sound-level meter is designed to be easily portable. It weighs only slightly over 20 pounds and is completely self-contained, including batteries.

▶ It is so simple in operation that non-technical personnel have no difficulty in using it.

▶ This instrument complies with all the standards for sound-level meters specified by the American Standards Association, the American Institute of Electrical Engineers, and the Acoustical Society of America.

▶ All three frequency response characteristics recommended by the A.S.A. are provided.

▶ In addition to the standard meter characteristics, a heavily damped movement for reading the average level of rapidly fluctuating sounds is provided.

SPECIFICATIONS

Sound Level Range: Calibrated in decibels from 24 db to 140 db above the standard reference level of 10^{-16} watts (a pressure of 0.0002 dynes) per square centimeter in a free, progressive wave at 1000 cycles.

Frequency Characteristics: The frequency characteristic of the sound-level meter is adjustable to follow three different curves. The first and second of these are, respectively, the 40 and 70 db equal-loudness contours in accordance with the current standard specified by the American Standards Association. The third frequency response characteristic gives a substantially equal response to all frequencies within the range of the instrument. This characteristic is used when measuring extremely high sound levels or when using the instrument with TYPE 760-A Sound Analyzer.

Microphone: The microphone mounts on a folding bracket on top of the instrument and folds down into a recess in the panel when not in use. It can be removed from its mounting bracket for use with an extension cable and tripod (see price list).

The microphone is of the crystal diaphragm type with an essentially non-directional response characteristic. It is rugged and stable, and its sensitivity is substantially unaffected by ordinary changes in temperature and humidity.

The absolute level of all microphones is checked at several frequencies against a standard microphone, whose calibration is periodically checked by the U. S. Bureau of Standards.

The high input impedance of the meter eliminates errors due to deviations in microphone impedance.

Meter and Attenuator: The sound level is given by the sum of the meter reading and the reading of a stepped attenuator. A single knob controls two attenuators furnishing a total of 100 db attenuation in steps of 10 db. The indicating meter is approximately linear in decibels, and its scale is open and easily read. It covers a 16 db range, thus providing a satisfactory overlap between the steps of the attenuator. A SLOW-FAST switch makes available two meter speeds. With the control switch in the FAST position the ballistic characteristics of the

meter simulate those of the human ear and agree with the current standards of the American Standards Association. In the SLOW position, the meter is heavily damped for observing the average level of rapidly fluctuating sounds.

Calibration: A means is provided for standardizing the sensitivity of the instrument in terms of any a-c power line of approximately 115 volts.

Accuracy: The frequency response curves of the TYPE 759-B Sound-Level Meter fall within the tolerances specified by the current ASA standards. When the amplifier sensitivity is standardized the absolute accuracy of sound-level measurements is within ± 1 decibel for average machinery noises in accordance with the ASA standards.

Temperature and Humidity Effects: Readings are independent (within 1 db) of temperature and humidity over the ranges of room conditions normally encountered.

Extension Cable and Tripod: An extension cable and tripod (TYPE 759-P21) can be supplied for using the microphone at a distance from the sound-level meter. A correction curve is supplied, giving the cable correction as a function of temperature. This temperature correction is usually negligible below 85° Fahrenheit.

Batteries: A single block battery (BA48, Burgess 6TA60) is used and one is supplied with the instrument. The TYPE 1261-A Power Supply is available if a-c operation is desired (see page 102).

Tubes: Three 1N5-GT/G and one 1D8-GT are required. A complete set is supplied with the instrument.

Accessories Supplied: Power cord (for calibration check); telephone plug; spare pilot lamp.

Case: The sound-level meter is mounted in a shielded carrying case of durable airplane-luggage construction.

Dimensions: The over-all dimensions are approximately: (height) 11½ x (length) 13½ x (width) 9½ inches.

Net Weight: 22¼ pounds, with battery; 17¼ pounds, without battery.

| Type | | Code Word | Price |
|---------|--|------------|----------|
| 759-B | Sound-Level Meter..... | NOMAD | \$320.00 |
| | Replacement Battery for above..... | NOMADNUBAT | 5.15 |
| 759-P21 | Extension Cable (25 ft.) and Tripod .. | KIMBO | 25.00 |

PATENT NOTICE. See Notes 1, 2, page vi.



ACCESSORIES

VIBRATION PICKUP AND CONTROL BOX



The vibration pickup and control box plug into the sound-level meter in place of the microphone, as shown here.

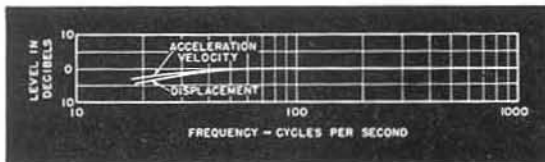

Over-all frequency response characteristic of the vibration pickup, control box, and sound-level meter.

The TYPE 759-P35 Pickup and TYPE 759-P36 Control Box have been designed for use with the TYPE 759-B Sound-Level Meter.

The TYPE 759-P35 Vibration Pickup is an inertia-operated crystal device which generates a voltage proportional to the acceleration of the vibrating body. By means of integrating networks in the control box, voltages proportional to velocity and displacement can also be delivered to the sound-level meter. The desired response is selected by means of a three-point switch on the control box.

SPECIFICATIONS

Calibration: The db readings of the sound-level meter can be converted into absolute values of displacement, velocity, or acceleration by means of calibration data.

Range: The range of measurement of the pickup and control box when used with the TYPE 759-B Sound-Level Meter is approximately as follows:

R-m-s Amplitude — 30 micro-inches (minimum).

R-m-s Velocity — 1000 micro-inches per second (minimum). The upper limit of velocity and displacement measurements is dependent on the frequency and is determined by the maximum acceleration permissible before non-linearity occurs (10 g).

R-m-s Acceleration — 0.3 to 3900 in./sec/sec (10 g).

Frequency Characteristic: A typical response curve is shown. For frequencies below 20 cycles per second the TYPE 761-A Vibration Meter should be used.

Mounting: Both control box and pickup are housed in metal containers, finished in black lacquer.

Net Weight: TYPE 759-P35 Vibration Pickup, 8 ounces (pickup only); pickup plus cable and tips, 1 pound; TYPE 759-P36 Control Box, 1 pound, 6 ounces.

| Type | Code Word | Price |
|---------|-----------------------|---------------|
| 759-P35 | Vibration Pickup | NOSEY \$40.00 |
| 759-P36 | Control Box | NANNY 50.00 |

A-C POWER SUPPLY FOR THE TYPE 759-B SOUND-LEVEL METER

The TYPE 1261-A Power Supply described on page 102 can be used to operate the TYPE 759-B from the a-c supply line.

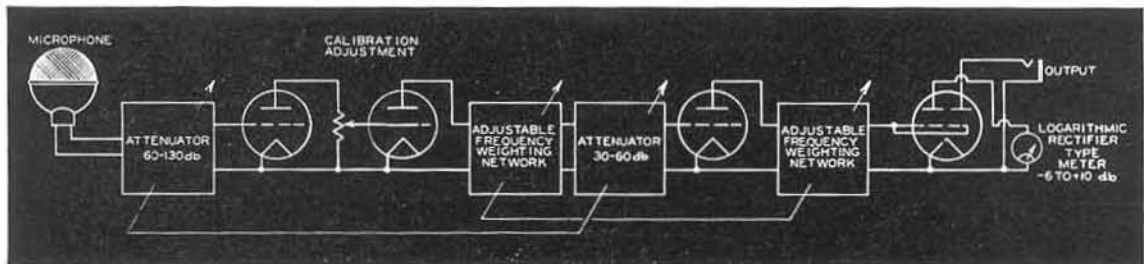

Functional block diagram of the TYPE 759-B Sound-Level Meter.

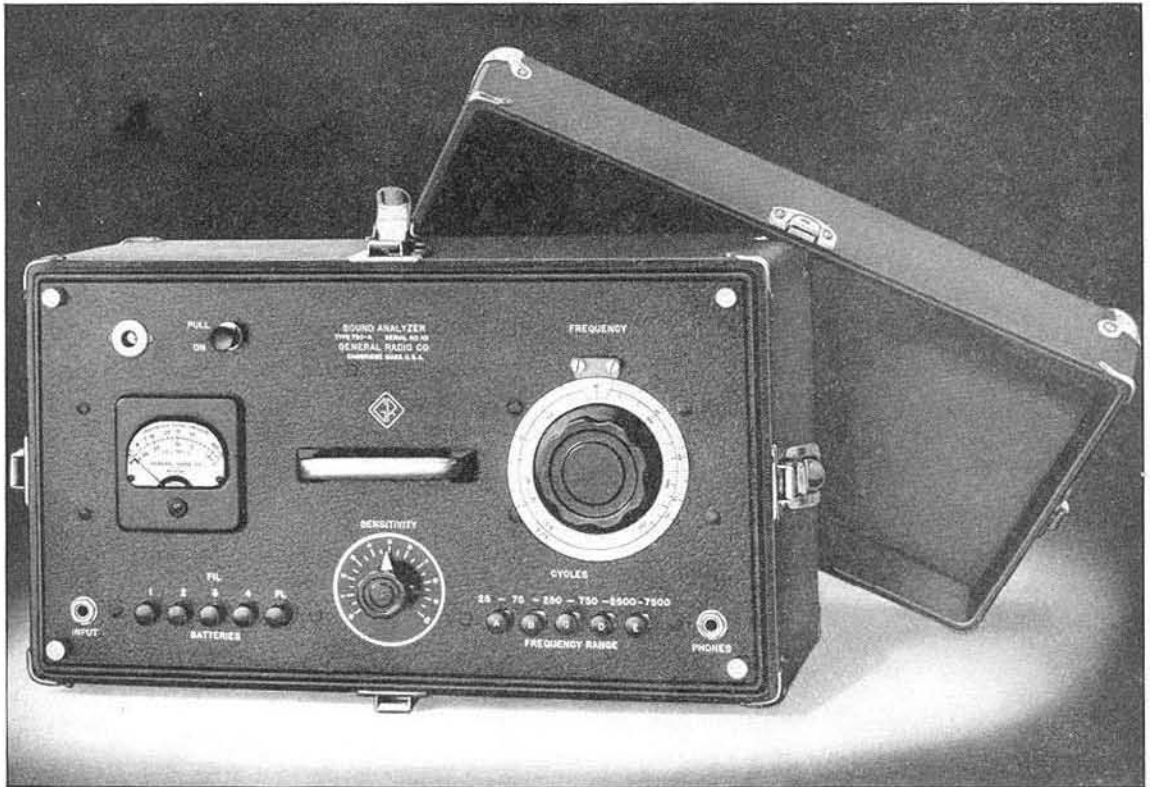

TYPE 760-A SOUND ANALYZER

USES: The TYPE 760-A Sound Analyzer has been designed particularly for analyzing machinery noises or noise levels caused mainly by electrical or mechanical equipment. The instrument is particularly well adapted for analyzing the sound made by automobile and airplane motors and industrial or household equipment. In the communications laboratory, this instrument is useful as a harmonic analyzer and as a selective bridge balance indicator.

DESCRIPTION: The TYPE 760-A Sound Analyzer consists of a three-stage selective amplifier, operating on the degeneration principle and having a constant percentage band width, combined with a vacuum-tube voltmeter having approximately logarithmic characteristics over a wide range.

The principles on which the analyzer operates are shown in the accompanying diagram.

The instrument was designed particularly for use with the TYPE 759 Sound-Level Meter, and this combination provides an accurate and convenient means for measuring not only the actual level of sound, but also the relative amplitudes of the component frequencies.

FEATURES: ▶ Simplicity and convenience of operation were considered to be of primary importance in the design of this instrument.

▶ The entire frequency range of the instrument can be scanned quickly and easily. The frequency is read from a single dial, which can be rotated continuously in either direction, and a set of push-button multipliers.

▶ Stabilized circuit precludes the necessity of battery adjustments and a ballast lamp maintains constant voltmeter accuracy regardless of battery condition.

▶ A single logarithmic meter scale covers the complete amplitude range so that no meter multipliers are needed.

▶ External magnetic fields have no appreciable effect on accuracy because the circuit elements consist only of resistors and capacitors.

▶ The band width is a constant percentage of the frequency to which the analyzer is tuned, which facilitates measurements on machines that do not run at absolutely constant speed.

▶ The case matches that of TYPE 759-B Sound-Level Meter, and the instrument is small, portable, and light in weight.

▶ As a bridge balance indicator, the analyzer has the advantages of a high degree of selectivity and a logarithmic meter scale.

SOUND ANALYZER



The TYPE 759-B Sound-Level Meter and the TYPE 760-A Sound Analyzer are useful for the study and analysis of office machinery noises (shown above is an automatic addressing machine) as well as for measurements on industrial machinery, operating household appliances, and other equipment.

SPECIFICATIONS

Frequency Range: Calibrated directly in cycles per second from 25 to 7500. This total range is covered in five complete turns of the tuning knob, the ranges on the various dial rotations being 25 to 75, 75 to 250, 250 to 750, 750 to 2500, and 2500 to 7500 cycles. A push-button switch allows immediate change of the main control to any one of these ranges.

Frequency Calibration: The accuracy of frequency calibration is $\pm 1\frac{1}{2}\%$ of the frequency to which the dial is set or $\pm 1\frac{1}{2}$ cycles per second, whichever is the larger.

Voltage Range: The analyzer will give usable indications on input voltages ranging from 1 millivolt to 10 volts. The meter scale is calibrated for reading directly component tones down to 1% of the sound pressure (or voltage) of the fundamental or loudest component. Accordingly, to make full use of this feature, the input voltage at the loudest component or fundamental should be 0.1 volt or higher.

Input Impedance: The input impedance is between 20,000 and 30,000 ohms, depending upon the setting of the sensitivity control. A blocking capacitor is in series with the input.

Frequency Response: The response is flat within ± 2 db over the entire range. At points where two ranges overlap, the sensitivity is the same on either range, within ± 1 db.

Band Width: The average selectivity is such that the relative attenuation is 3 db at 1% off the peak to which the analyzer is tuned.

Temperature and Humidity Effects: Under very severe conditions of temperature and humidity only slight, and generally negligible, shifts in calibration, sensitivity, and band width will occur.

Meter: The indicating meter is calibrated down to 1% of the fundamental or loudest component of the sound. A decibel scale is also included, extending to 40 decibels below the fundamental or loudest component.

Telephones: A jack is provided on the panel for plugging in a pair of head telephones, in order to listen to the actual component of the sound to which the instrument is tuned. This is also useful when the analyzer is used as a bridge-balance indicator.

Tubes: Three 11A and one 1S5 tubes are required. A neon regulator tube (TYPE 2LAG-949) is also used. A complete set of tubes is supplied with the instrument.

Batteries: The batteries required are four Burgess No. 2FBP 1.5-volt batteries, or the equivalent, and three Burgess No. Z30NX 45-volt batteries, or the equivalent. A compartment is provided in the case of the analyzer for holding all batteries, and connections are automatically made to the batteries when the cover of this compartment is closed. A set of batteries is included in the price of the instrument.

Accessories Supplied: A shielded cable-and-plug assembly for connecting the analyzer to the sound-level meter; and one spare neon regulator tube.

Case: The analyzer is built into a shielded carrying case of airplane-luggage construction.

Dimensions: (Length) 18 x (width) 10 x (height) 11 $\frac{1}{2}$ inches, over-all.

Net Weight: 36 $\frac{1}{2}$ pounds, with batteries; 29 $\frac{3}{4}$ pounds, without batteries.

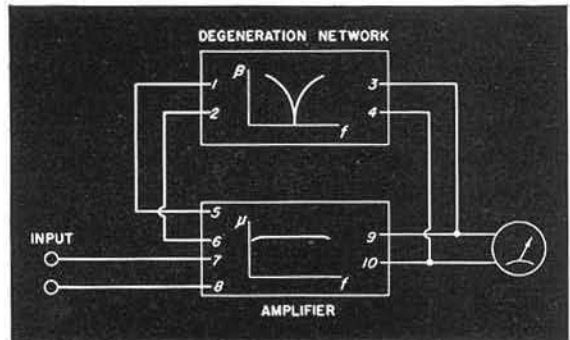

A functional diagram of the general type of circuit used in TYPE 760-A Sound Analyzer. The system consists of an amplifier with a propagation constant μ and a feedback network with a propagation constant β having the frequency characteristics shown above. The degeneration network is highly selective, and at its null point the normal gain of the amplifier is obtained. At lower and higher frequencies degeneration occurs, and the gain of the amplifier is greatly reduced.

| Type | Code Word | Price |
|--|-----------|----------|
| 760-A Sound Analyzer | ATTAR | \$400.00 |
| Set of Replacement Batteries for Above | ATTARDBAT | 10.19 |

PATENT NOTICE: See Notes 1, 24, page vi.



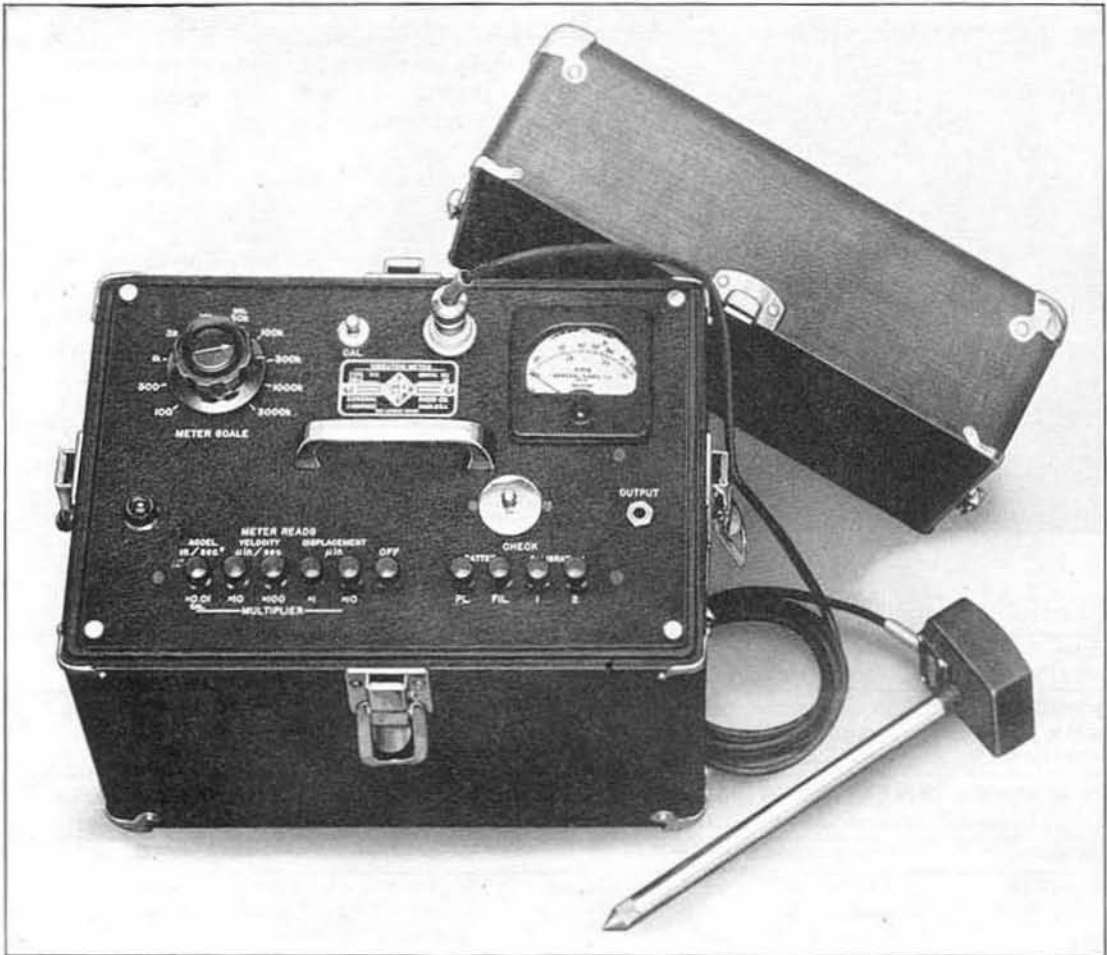

TYPE 761-A VIBRATION METER

USES: With the TYPE 761-A Vibration Meter measurements of the vibratory characteristics of machines and structures can be made quickly and easily. The excellent low-frequency response of this instrument makes possible the measurements of vibrations at frequencies as low as two cycles per second. This permits the study of the operation of belt drives and of the effectiveness of mountings designed to reduce vibrations in adjacent structures.

For the manufacturer of machinery and equipment, the TYPE 761-A Vibration Meter is extremely useful in research, design, and production testing. Maintenance engineers will find the instrument useful for checking the operating condition of bearings, gear trains, and other mechanisms. With this instrument excessive vibrations due to improper adjustment or design and to structural resonances can be located and measured.

DESCRIPTION: The TYPE 761-A Vibration Meter consists essentially of a vibration pick-

up, an adjustable attenuator, an amplifier, and a direct-reading indicating meter. The pickup is of the inertia-operated crystal type which delivers a voltage proportional to the acceleration of the vibratory motion. An integrating network converts this output, when desired, to a voltage proportional to velocity or displacement. The type of response is selected by push-button switches. Thus the acceleration, velocity, and displacement of a vibrating body can be measured independently.

Calibrations are made in terms of r-m-s values. The basic units in which the instrument is calibrated, inches and seconds, are the simplest and least confusing of those commonly used. Acceleration is read directly in terms of inches per second per second, velocity in micro-inches per second, and displacement in micro-inches. Calibrations are made on a motor-driven precision vibrator, which produces essentially sinusoidal vibrations.

VIBRATION METER

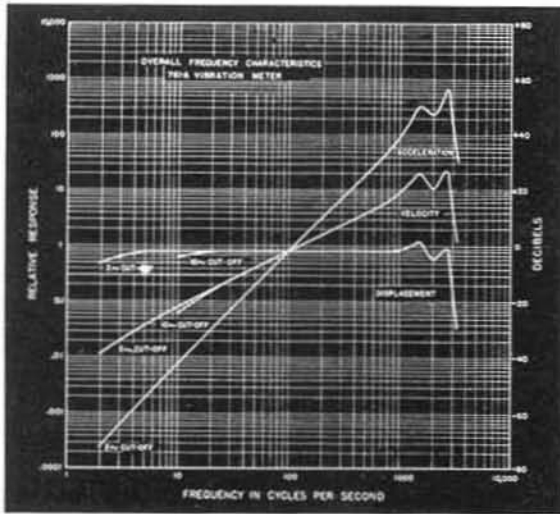

FEATURES: ▶ Portable, self-contained and simple to operate, the vibration meter is similar in design and appearance to the sound-level meter and sound analyzer.

▶ No reference to calibration figures is necessary because the meter indicates directly the quantity under measurement.

▶ Flexibility and completeness in the measurement of vibration are afforded by the three response characteristics — displacement, velocity, and acceleration — and the low-frequency response — 2 cycles per second.

(Left) Over-all frequency characteristics of the vibration meter, including the vibration pickup.

SPECIFICATIONS

RANGES: The vibration meter is direct-reading in the units shown in the range table below.

| Vibration Quantity | Range |
|--------------------|---|
| Displacement | 16 micro-inches to 30 inches, rms. |
| Velocity | 160 micro-inches per second to 300 inches per second, rms. |
| Acceleration | 0.160 inch per second per second to 3900 inches per second per second, rms. |

RESPONSE CHARACTERISTICS: The response follows theoretical curves of the quantity measured, vs. frequency within the following tolerances.

| Quantity | Range | Tolerance | Frequency Range |
|--------------|---------------------------------------|-----------|-------------------------------------|
| Acceleration | 0.160 in./sec/sec to 3900 in./sec/sec | ±10% | 4 to 500 cps Down 25% at 2 cps |
| Velocity | 1600 μin./sec to 300 in./sec | ±10% | 5 to 500 cps Down 40% at 2 cps |
| Velocity | Below 1600 μin./sec | ±15% | 20 to 500 cps Down 25% at 10 cps |
| Displacement | 160 μin. to 30 in. | ±10% | 10 to 500 cps Down 50% at 2 cps |
| Displacement | Below 160 μin. | ±15% | 20 to 500 cps Down 25% at 10 cps |

Above 500 cps the error increases and may reach ±30% at 1000 cps. This is caused by the differences in response of individual pickups near resonance.

Pickup Unit: The vibration pickup is of the inertia-operated crystal type, housed in a cast aluminum container. The maximum vibration acceleration which can be impressed upon the pickup before non-linearity occurs is 10 g or 3900 inches per second per second. Point and ball tips and an 8-inch extension rod are supplied.

Meter: The indicating meter has a scale which reads directly in the quantity being measured — r-m-s micro-inches for displacement, r-m-s micro-inches per second for velocity, and r-m-s inches per second per second for acceleration.

Attenuators: A 10-step attenuator is provided which changes the meter scale calibration over a range of 30,000 to 1. Additional multipliers are provided which indicate the correct units of measurement and multiplying factors for each response characteristic.

Calibration: A calibrating circuit is provided in the instrument which, by connection to any a-c power line, makes it possible to check the over-all calibration of the vibration meter, excluding the vibration pickup.

Telephones: A jack is provided on the panel for plugging in a pair of head telephones in order to listen to the vi-

brations being measured, for connecting the TYPE 762-B Vibration Analyzer, or for connecting a cathode-ray oscillograph. Practically any load impedance can be impressed across this output telephone jack without affecting the reading of the meter.

Tubes: Three 1N5-GT/G tubes and one 1D8-GT tube are required. A complete set of tubes is supplied.

Battery: A single battery unit, BA48, Burgess 6TA60, which supplies the necessary plate and filament voltages, is included.

Accessories Supplied: Power cable for calibration check, spare pilot lamp, and plug for output jack.

Case: The unit is built into a shielded carrying case of airplane-luggage construction, covered with durable black waterproof material, and equipped with chromium-plated corners, clasps, etc.

Dimensions: The over-all dimensions are approximately: (height) 12½ inches x (length) 13½ inches x (width) 9½ inches.

Net Weight: 22¾ pounds with battery; 17¾ pounds without battery.

| Type | Code Word | Price |
|-------------------------------------|------------|----------|
| 761-A Vibration Meter | VIRUS | \$425.00 |
| Replacement Battery for Above | VIRUSADBAT | 5.15 |

PATENT NOTICE. See Note 1, page vi.





TYPE 762-B VIBRATION ANALYZER

USES: The TYPE 762-B Vibration Analyzer makes possible the analysis of vibration phenomena having fundamental frequencies as low as 2.5 cycles per second. It is intended primarily for use with the TYPE 761-A Vibration Meter but can also be used for general harmonic analysis of very-low-frequency voltages in the laboratory.

The frequency range covered (2.5 cycles to 750 cycles) includes practically all frequencies normally encountered in vibration studies, from the fundamental vibrations of ships and other large structures to the unbalance vibrations of high-speed centrifuges.

DESCRIPTION: The analyzer is similar in all essential characteristics of performance, construction, operation, and appearance to the TYPE 760-A Sound Analyzer (page 13) except that the frequency has been lowered by a factor of 10 and provision has been made for operation with broad selectivity if desired. The latter arrangement is particularly useful in identifying components in the two lowest frequency ranges (2.5 to 25 cycles per second) and in making analyses involving components that vary slightly about a mean frequency.

SPECIFICATIONS

Frequency Range: 2.5 to 750 cycles, covered in five ranges as follows: 2.5 to 7.5, 7.5 to 25, 25 to 75, 75 to 250, 250 to 750.

Band Width: For the sharp selectivity position, the relative attenuation is approximately 30% (3 db) at a frequency differing by 1% from that to which the analyzer is tuned. For the broad selectivity position, the attenuation is at least 30% for a frequency difference of 5%. At one octave from the peak, the relative attenuations are at least 98% (35 db) and 90% (20 db), respectively.

Frequency Calibration: The accuracy of frequency calibration of the sharp selectivity network is $\pm 1\frac{1}{2}\%$ or $\pm 1\frac{1}{2}$ cycles, whichever is the larger, over the three

highest ranges (25 to 750 cycles); on the two lower ranges (2.5 to 25 cycles), the accuracy is $\pm 5\%$ or ± 0.2 cycle, whichever is the larger. The frequency as determined with the broad selectivity network deviates on the average by less than $\pm 2\%$ from that determined with the sharp selectivity network.

Frequency Response: The response of the sharp selectivity network is flat within ± 2 db over the entire range. At points where two ranges overlap, the sensitivity is the same on either range within ± 1 db. The sensitivity of the broad selectivity network is the same as that of the sharp selectivity network within ± 2 db.

For other specifications see TYPE 760-A, page 14.

| Type | Code Word | Price |
|----------------------------------|-----------|----------|
| 762-B Vibration Analyzer | AWARD | \$475.00 |

PATENT NOTICE. See Notes 1, 24, page vi.



VARIACS

VARIAC*

USES: The VARIAC is a voltage control that finds applications in shop and laboratory wherever a-c voltage must be adjusted smoothly and continuously. Thousands are in use for motor speed control; for heat control on electric ovens and furnaces; for illumination control in auditoriums, photographic studios, and darkrooms; as voltage controls in laboratory testing and research; and as output voltage controls in transformer-rectifier systems.

Although designed primarily for use at ordinary power frequencies, VARIACS are equally useful as voltage controls in power circuits operating at higher frequencies.

In the testing and calibration of voltmeters, ammeters, wattmeters, and power-factor meters, the VARIAC is a convenient source of adjustable voltage, and, by using combinations of VARIACS, the phase of the test voltage can be varied, as well as the amplitude.

Two and three-gang assemblies of VARIACS are available for use on three-phase systems. With the largest units, volt-ampere loads up to 25 kva can be controlled in this way. Although VARIACS are built for 115 and 230-volt service, they can be used on circuits of higher or lower voltage in conjunction with fixed-ratio auxiliary transformers and auto-transformers.

DESCRIPTION: The VARIAC is a continuously variable autotransformer supplying an output voltage from zero to *above* line voltage. It consists of a single-layer winding on a toroidal iron core. As the dial is rotated a carbon-brush contact traverses the winding, "tapping off" a portion of the total voltage across the winding. The brush is always in contact with the winding, and the voltage between turns is always less than 1 volt, even in the largest models, while in the smallest model it is only about 0.3 volt. The actual increments of voltage obtained as the dial is turned are always less than the voltage between turns, the action of the carbon

brush being such that the change in voltage is practically continuous. The resistance of the brush is so chosen that no excessive heating can occur in the short-circuited turn.

FEATURES: Compared to resistive methods of voltage control, the VARIAC has the advantages of high efficiency, smooth control, good voltage regulation, and comparatively small size. Because the output voltage is essentially independent of load, a linear variation of voltage is obtained. VARIACS also furnish output voltages above line voltage, making it possible to compensate for under-voltage lines.

► Today's VARIACS, the new V-models, are more useful, more reliable, and more efficient than ever before. Among their outstanding features are:

► Greatly increased ratio of output to weight.
► New unit brush — easily changed in a few seconds.

► Unaffected by vibration — constant pressure — brush holder cannot contact winding surface.

► Shaft reversal to convert from panel to table mounting is accomplished by loosening and tightening two screws — does not affect brush adjustment.

► Rubber feet prevent damage.

► Extra terminals for mid-winding taps facilitate the use of auxiliary transformers.

► Case easily and quickly removed — tabs automatically register the model number for all combinations.

► Direct-reading voltage scale has large, easily read numbers.

► Brush travel limited by resilient stop.

► Terminals have both screw and solder connections, easily accessible and logically arranged.

► Heavy duty switch in mounted small models breaks both sides of line.

► Attractive case — rounded contours — no sharp edges.

► Aluminum structural parts mean lighter weight and minimum corrosion.

► Durable black lacquer baked finish — wear and abrasion resistant.

► Uniform windings on newly designed machine.

► "Hyprolapped" commutator surface — plane oriented for uniform brush pressure and contact, with resultant minimum wear.

Functional diagram of the VARIAC.

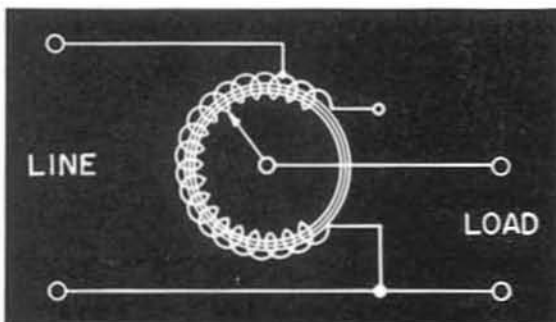

*Trade Mark Registered U. S. Patent Office.

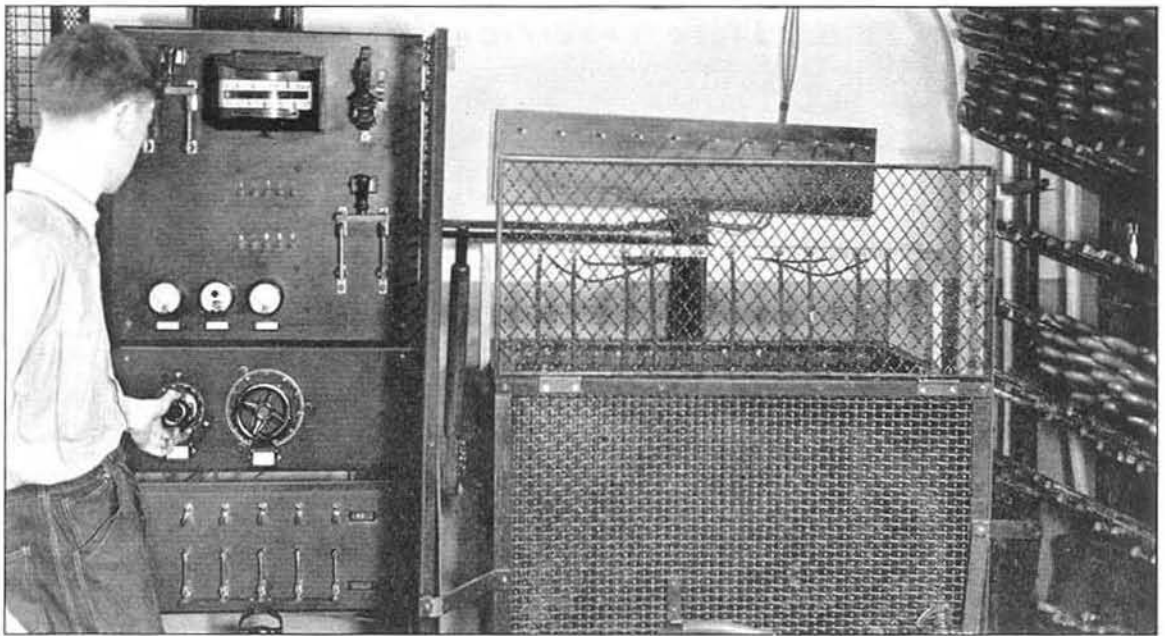

VARIACS used as convenient continuously-adjustable controls in high-voltage equipment designed for testing of linemen's rubber gloves. *Courtesy of Boston Edison Company.*

GENERAL SPECIFICATIONS

Models ranging in capacity from 170 va to 7 kva are listed on the next page. Specifications are for 50 to 60-cycle service.

Rated Current can be drawn from the VARIAC at any dial position. It is limited by heat loss in the winding.

Maximum Current can be drawn at low voltages or at voltages near the input voltage. It is limited by losses in the carbon brush. Currents up to 150% of this value can be drawn for brief periods without damage to the VARIAC.

Input Voltage is the voltage that should be applied to the input terminals to make the dial calibration correct. All 230-volt VARIACS have extra taps for use on 115-volt lines. When so used, the rated current is reduced by a factor of 2, and the regulation is not as good as with a 230-volt input. At 50 cycles the overvoltage connection must not be used if the input voltage is over 115 (or 230) volts.

Output Voltage is the range of voltage available at the output terminals, with rated voltage applied to the input terminals.

Load Rating is the maximum output current multiplied by input voltage. A VARIAC can handle, at any lower setting, a constant impedance load which draws at input voltage a current no greater than the "maximum current."

Temperature Rise: The ratings of VARIACS are based on a temperature rise of 50° Centigrade, or less, at 60 cycles. At 50 cycles, the temperature rise may exceed the above value slightly but the VARIAC can be safely operated at full voltage and current ratings.

Operation at 25 Cycles: On 25-cycle supply, VARIACS should be operated at one-half rated voltage or excessive heating will result. Thus 230-volt models can be used on 115-volt, 25-cycle lines.

Higher Frequencies: At frequencies above 60 cycles all VARIACS can be used at full rated current and voltage. No-load losses will be reduced compared to the 60-cycle values, but regulation will be poorer, owing to increased leakage reactance.

No-Load Loss is measured at 60 cycles with rated input voltage. The values quoted in the table are the guaranteed maxima.

Driving Torque is the torque required to turn the VARIAC shaft.

Terminals: (see also **Mounting** below) Type 200-B is furnished with threaded terminal studs and soldering lugs. Types V-5, V-10, and V-20 have combined soldering and screw-type terminals; Type 50 models have self-locking terminals, and provision for attaching BX cable.

Dial: A reversible dial, reading in output voltage for the overvoltage connection, is provided on all "V" models. One side is used for table mounting with rotating dial, the other for panel mounting, with fixed dial and rotating pointer. Dials can be supplied on special order engraved for maximum voltage equal to line voltage, if the overvoltage connection is not to be used. The total angle of rotation is 320°.

The Types 50-A, 50-B, and 200-B are supplied with reversible dials, one side of which is engraved for the overvoltage connection and one side for maximum voltage equal to line voltage.

Panel Thickness is the maximum thickness of panel on which the VARIAC can be mounted, with the shaft supplied.

Mounting: Type 200-B is supplied without case, for panel mounting. Type V-20 models are always supplied with case. Types V-5 and V-10 can be ordered either with or without case (the "M" models have cases). A terminal box cover, cord, and plug are provided on the "MT" models (see photograph on page 21). On special order, they can also be supplied without case, but with terminal box and line cord.

Dimensions: Over-all height for table mounting and depth behind panel for panel mounting are given in the table on next page. Complete dimensional sketches can be furnished on request.

Net Weight: See table on next page.

VARIACS

DETAILED SPECIFICATIONS

| Type | Load Rating (KVA) | Input Voltage (Volts) | Output Voltage (Volts) (Zero to—) | Rated Current (Amperes) | Maximum Current (Amperes) | 60 ~ No-Load Loss (Watts) | Driving Torque (Inch — Ounces) | Over-all Height for Table Mounting (Inches) | Maximum Panel Thickness (Inches) | Depth behind Panel (Inches) | Diameter of Variac Cylinder (Inches) | Add for Terminals (Inches) | Net Weight (Pounds) | Code Word | Price |
|---------|-------------------|-----------------------|--------------------------------------|-------------------------|---------------------------|------------------------------|-----------------------------------|--|-------------------------------------|-----------------------------|---|----------------------------|---------------------|--------------|---------|
| 200-B | .170 | 115 | 135 115 | 1 | 1.5 | 3 | 20-40 | 4 | 1/4 | 3 1/8 | 3 3/8 | 1/4 | 2 7/8 | BALSA | \$12.50 |
| V-5 | .862 | 115 | 135 115 | 5 | 7.5 | 9 | 20-40 | 5 | 3/8 | 3 21/32 | 4 13/16 | 1 1/32 | 6 3/4 | COBRA | 18.50 |
| V-5M | .862 | 115 | 135 115 | 5 | 7.5 | 9 | 20-40 | 5 | 3/8 | 4 | 4 15/16 | 9/32 | 7 | COPAL | 20.50 |
| V-5MT | .862 | 115 | 135 115 | 5 | 7.5 | 9 | 20-40 | 5 | 3/8 | 4 | 4 15/16 | 12 1/32 | 7 5/8 | CORAL | 25.00 |
| V-5H | .575 | 230 or 115 | 270 230 | 2 1* | 2.5 | 9 | 20-40 | 5 | 3/8 | 3 21/32 | 4 13/16 | 1 1/32 | 6 1/2 | CULPA | 21.00 |
| V-5HM | .575 | 230 or 115 | 270 230 | 2 1* | 2.5 | 9 | 20-40 | 5 | 3/8 | 4 | 4 15/16 | 3/32 | 6 3/4 | CUMIN | 23.00 |
| V-5HMT | .575 | 230 or 115 | 270 230 | 2 1* | 2.5 | 9 | 20-40 | 5 | 3/8 | 4 | 4 15/16 | 12 1/32 | 7 3/8 | CUPID | 27.50 |
| V-10 | 1.725 | 115 | 135 115 | 10 | 15 | 17 | 30-60 | 5 1/8 | 3/8 | 3 13/16 | 6 3/64 | 3/8 | 11 1/4 | HAZEL | 33.00 |
| V-10M | 1.725 | 115 | 135 115 | 10 | 15 | 17 | 30-60 | 5 1/8 | 3/8 | 4 5/32 | 6 17/64 | 5/16 | 11 3/8 | HEAVY | 35.50 |
| V-10MT | 1.725 | 115 | 135 115 | 10 | 15 | 17 | 30-60 | 5 1/8 | 3/8 | 4 5/32 | 6 17/64 | 1 11/16 | 12 1/8 | HELOT | 40.00 |
| V-10H | 1.15 | 230 or 115 | 270 230 | 4 2* | 5 | 17 | 30-60 | 5 1/8 | 3/8 | 3 13/16 | 6 3/64 | 3/8 | 10 5/8 | HINNY | 34.00 |
| V-10HM | 1.15 | 230 or 115 | 270 230 | 4 2* | 5 | 17 | 30-60 | 5 1/8 | 3/8 | 4 5/32 | 6 17/64 | 5/16 | 11 | HOARY | 36.50 |
| V-10HMT | 1.15 | 230 or 115 | 270 230 | 4 2* | 5 | 17 | 30-60 | 5 1/8 | 3/8 | 4 5/32 | 6 17/64 | 1 11/16 | 11 1/2 | HOBBY | 41.00 |
| V-20M | 3.45 | 115 | 135 115 | 20 | 30 | 27 | — | 5 1/2 | 3/8 | 4 1/8 | 7 7/8 | 1 13/16 | 22 3/4 | JEWEL | 55.00 |
| V-20HM | 2.30 | 230 or 115 | 270 230 | 8 4* | 10 | 27 | — | 5 1/2 | 3/8 | 4 1/8 | 7 7/8 | 1 13/16 | 21 1/2 | JIMMY | 55.00 |
| 50-A | 5.00 | 115 | 135 115 | 40 | 45 | 60 | 250-500 | 10 1/8 | 1 1/2 | 7 1/8 | 16 3/16 | — | 85 | TOKEN | 140.00 |
| 50-B | 7.00 | 230 or 115 | 270 230 | 20 10* | 31 | 75 | 250-500 | 10 1/8 | 1 1/2 | 7 1/8 | 16 3/16 | — | 81 | TOPAZ | 140.00 |

*With 115-volt input applied across half the winding.
Load rating is then reduced to one-half the value shown.

PATENT NOTICE. See Note 11, page vi.



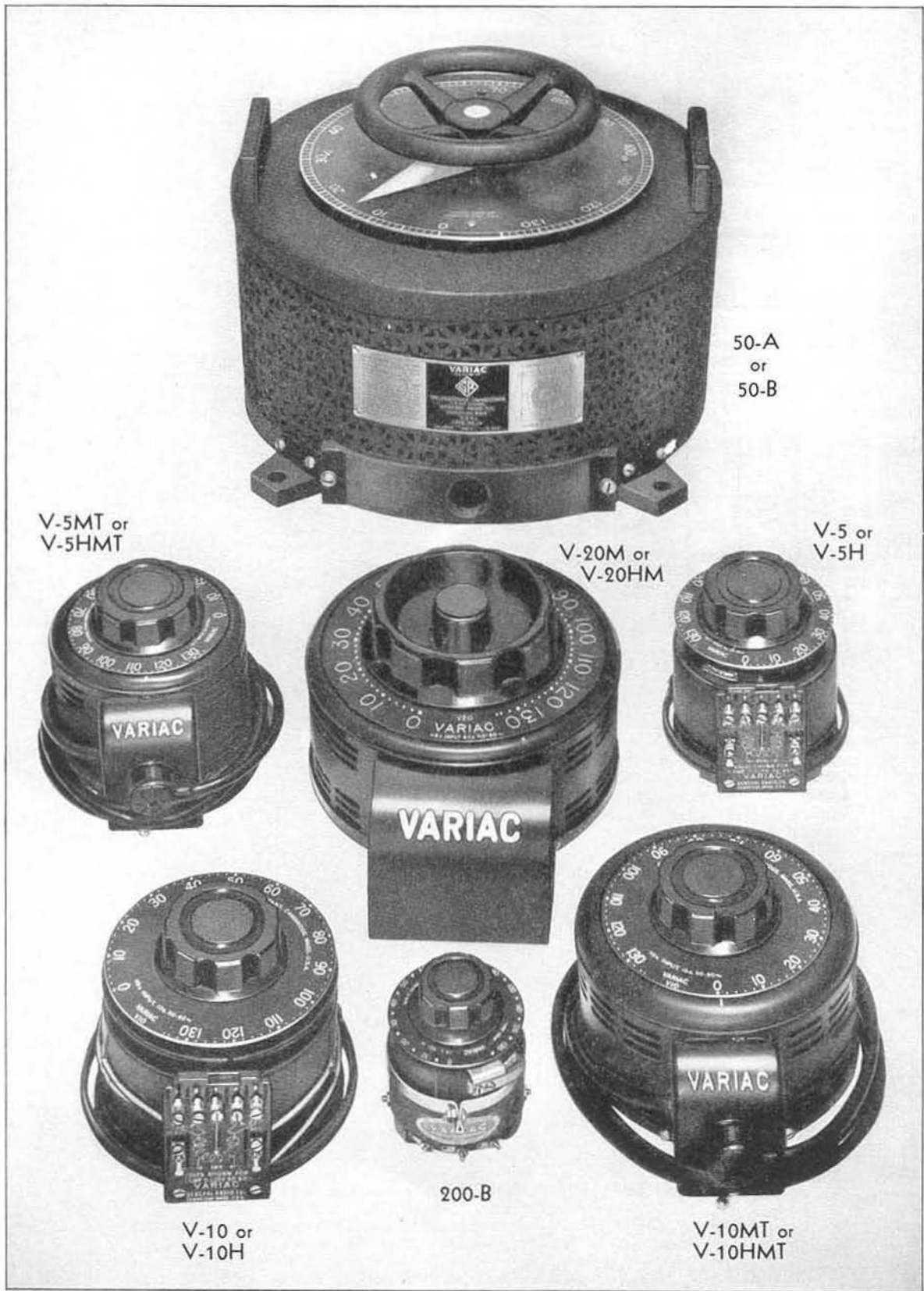

50-A
or
50-B

V-5MT or
V-5HMT

V-20M or
V-20HM

V-5 or
V-5H

V-10 or
V-10H

200-B

V-10MT or
V-10HMT

VARIACS

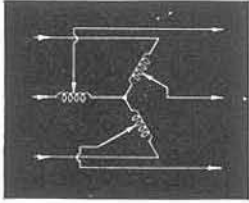

A Wye-connected three-phase arrangement of VARIACS.

MULTIPLE OPERATION OF VARIACS

Two and three-gang VARIAC assemblies are available for controlling several circuits from a single dial, or for controlling 3-phase circuits in the same manner that one VARIAC controls a single-phase circuit.

In polyphase circuits a large variety of input and output voltage combinations is possible. The Wye and open-delta connections listed are most frequently used, although the closed-delta finds occasional application.

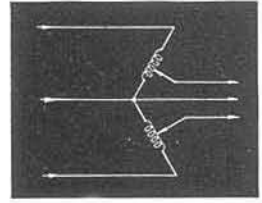

A three-phase arrangement of VARIACS in the open-delta circuit.

| Input Three-Phase Line Voltage | Kva | | Output | | Three-Phase Line Voltage | Type of Assembly | Circuit |
|--------------------------------------|---------------------|-----------------------|----------------------------------|---------|-----------------------------|---------------------|------------|
| | At Input Voltage | At Maximum Voltage | Line Current in Amperes Rated | Maximum | | | |
| 230 | 1.15 | 1.08 | 2.0 | 2.5 | 0-270 | V-5H-G2 | Open-Delta |
| 230 | 2.30 | 2.16 | 4.0 | 5.0 | 0-270 | V-10H-G2 | Open-Delta |
| 230 | 3.00 | 3.00 | 5.0 | 7.5 | 0-230 | V-5-G3 | Wye |
| 230 | 4.60 | 4.32 | 8.0 | 10.0 | 0-270 | V-20H-G2 | Open-Delta |
| 230 | 6.00 | 6.00 | 10.0 | 15.0 | 0-230 | V-10-G3 | Wye |
| 230 | 12.0 | 12.0 | 20.0 | 30.0 | 0-230 | V-20-G3 | Wye |
| 230 | 18.0 | 18.0 | 37.5 | 45.0 | 0-230 | 50-AG3 | Wye |
| 230 | 12.5 | 9.40 | 20.0 | 31.0 | 0-270 | 50-BG2 | Open-Delta |
| 460 | 2.00 | 2.00 | 2.0 | 2.5 | 0-460 | V-5H-G3 | Wye |
| 460 | 4.00 | 4.00 | 4.0 | 5.0 | 0-460 | V-10H-G3 | Wye |
| 460 | 8.00 | 8.00 | 8.0 | 10.0 | 0-460 | V-20HG-3 | Wye |
| 460 | 25.0 | 25.0 | 20.0 | 31.0 | 0-460 | 50-BG3 | Wye |

VARIAC ASSEMBLIES

| Type | Description | Net Weight in Pounds | Code Word | Price |
|----------|--------------------|-------------------------|------------|---------|
| V-5-G2 | 2-Gang V-5 | 16½ | COBRAGANDU | \$49.00 |
| V-5-G3 | 3-Gang V-5 | 23½ | COBRAGANTY | 68.50 |
| V-5H-G2 | 2-Gang V-5H | 16 | CULPAGANDU | 54.00 |
| V-5H-G3 | 3-Gang V-5H | 22¾ | CULPAGANTY | 76.00 |
| V-10-G2 | 2-Gang V-10 | 27 | HAZELGANDU | 79.00 |
| V-10-G3 | 3-Gang V-10 | 38½ | HAZELGANTY | 113.00 |
| V-10H-G2 | 2-Gang V-10H | 25¾ | HINNYGANDU | 81.00 |
| V-10H-G3 | 3-Gang V-10H | 36¾ | HINNYGANTY | 116.00 |
| V-20-G2 | 2-Gang V-20 | 53 | JEWELGANDU | 126.00 |
| V-20-G3 | 3-Gang V-20 | 75¾ | JEWELGANTY | 182.00 |
| V-20H-G2 | 2-Gang V-20H | 50½ | JIMMYGANDU | 126.00 |
| V-20H-G3 | 3-Gang V-20H | 72 | JIMMYGANTY | 182.00 |
| 50-AG2 | 2-Gang 50-A | 180 | TOKENGANDU | 310.00 |
| 50-AG3 | 3-Gang 50-A | 265 | TOKENGANTY | 460.00 |
| 50-BG2 | 2-Gang 50-B | 175 | TOPAZGANDU | 310.00 |
| 50-BG3 | 3-Gang 50-B | 256 | TOPAZGANTY | 460.00 |
| 50-P1 | Choke | 1¼ | PARALLCHOK | 10.00 |

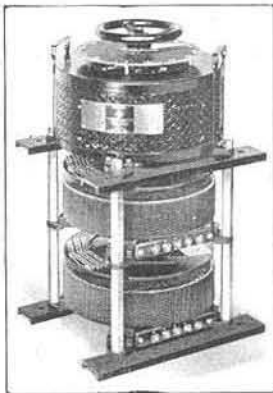

PARALLEL OPERATION

The TYPE 50-P1 Choke is available for parallel operation of two TYPE 50 VARIACS. Connections for this choke are shown in the sketch. The choke serves to equalize the currents from the two VARIACS and also to limit the flow of circulating currents. The use of a choke with smaller sizes of VARIACS is not recommended, because better results can be obtained by using a single larger unit.

(Left) View of TYPE 50-G3 Variac Assembly.

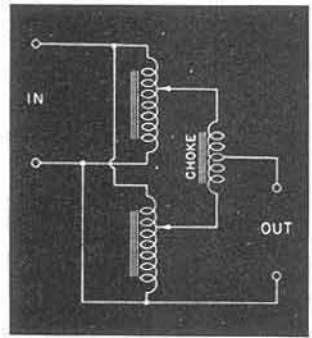

RESISTORS



DECADE RESISTORS

RESISTANCE
STANDARDS

ATTENUATORS

VOLTAGE DIVIDERS

RHEOSTATS

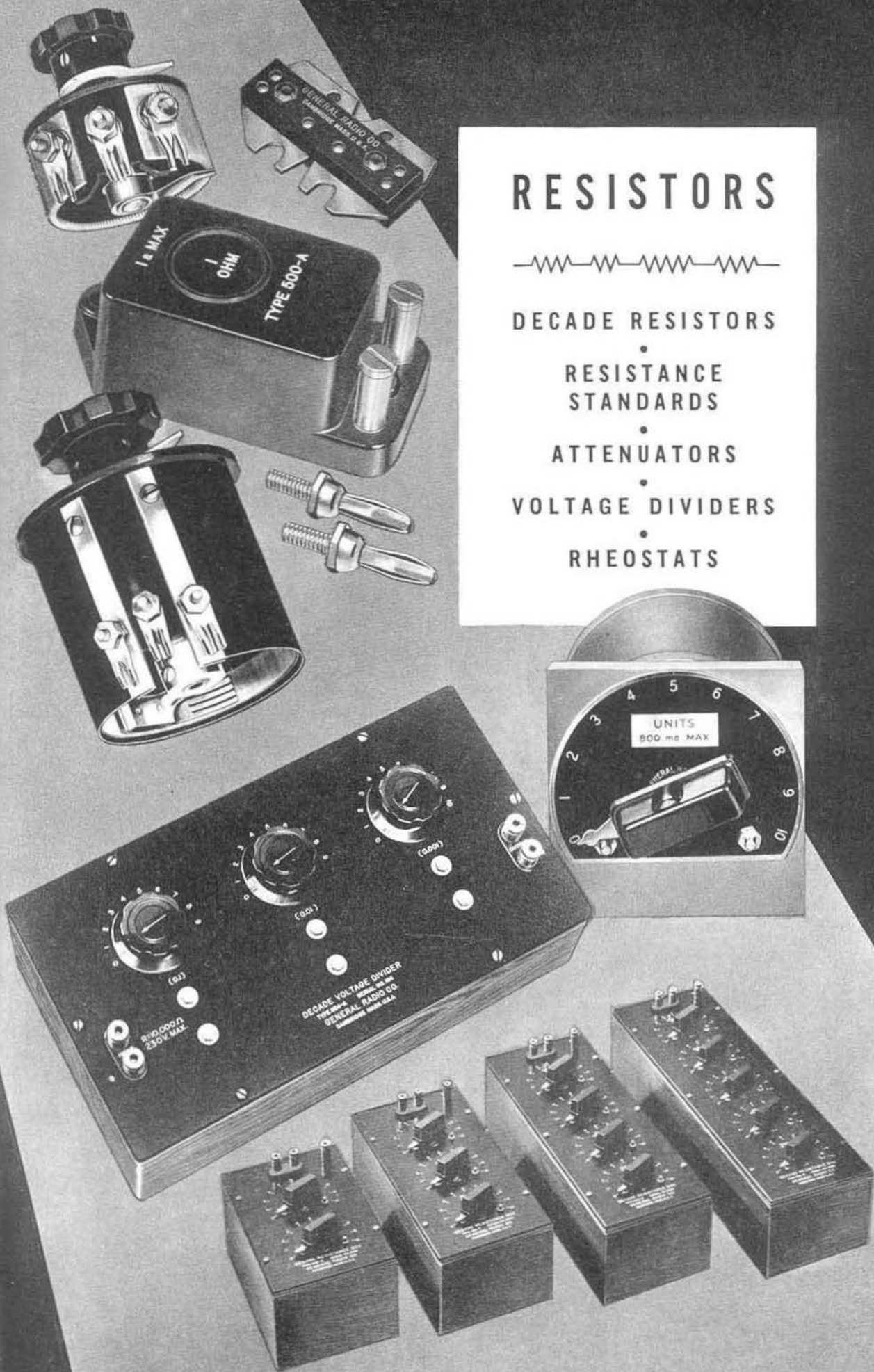

RESISTORS

Resistors designed for use at electrical communication frequencies differ from those intended for use only on direct current in that low reactance and constancy of resistance as the frequency is varied are of considerably more importance than extreme accuracy of adjustment. Inevitably, resistors have capacitance and inductance associated with them, and these residual impedances become increasingly important as the frequency is raised, acting to change the terminal resistance from its low-frequency value.

For frequencies where the resistance and its associated residual impedances behave as lumped parameters the equivalent circuit of a resistor can be represented as shown in Figure 1. The inductance L is the equivalent inductance between the terminals, and is effectively in series with the resistance, while the equivalent capacitance C appears across the terminals of the resistor. The expressions for the effective terminal resistance R_e and reactance X_e of this circuit are:

$$R_e = \frac{R}{(1 - \omega^2 LC)^2 + (\omega CR)^2} \quad (1)$$

$$X_e = \frac{\omega[L(1 - \omega^2 LC) - CR^2]}{(1 - \omega^2 LC)^2 + (\omega CR)^2}$$

At low frequencies where the terms in ω^2 are negligible compared to unity,

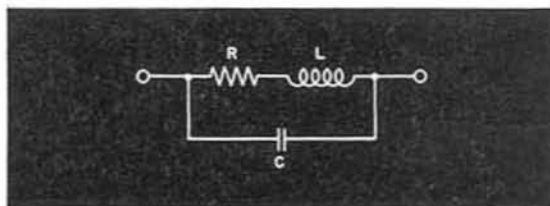

Figure 1. Equivalent circuit of a resistor showing the residual impedances associated with the resistance.

$$R_e = R$$

$$L_e = L - R^2 C$$

$$C_e = C - \frac{L}{R^2} \quad (2)$$

At higher frequencies the way in which R_e and X_e vary with frequency is best shown by expressing all the quantities as ratios.

$$\frac{R_e}{R} = \frac{1}{\left[1 - \left(\frac{f}{f_0}\right)^2\right]^2 + D_0^2 \left(\frac{f}{f_0}\right)^2} \quad (3)$$

$$\frac{X_e}{R} = \frac{f}{f_0 D_0} \frac{1 - \left(\frac{f}{f_0}\right)^2 - D_0^2}{\left[1 - \left(\frac{f}{f_0}\right)^2\right]^2 + D_0^2 \left(\frac{f}{f_0}\right)^2}$$

where f_0 is the resonant frequency determined by L and C and the dissipation factor at resonance is

$$D_0 = \frac{1}{Q_0} = \frac{R}{\sqrt{L/C}} = \frac{R}{2\pi f_0 L} \quad (4)$$

These normalized resistive and reactive components are plotted in terms of the ratio $\frac{f}{f_0}$ and the parameter D_0 in Figures 2 and 3.

For values of D_0^2 less than 2, the resistance increases with frequency to a maximum and then decreases to zero. For values of D_0^2 of 2 or greater, the resistance never rises above unity. The same sort of behavior occurs for reactance, except that the value of D_0^2 is 1 for the monotonic condition.

Dielectric losses in the lumped portion of the shunt capacitance C of Figure 1 are equivalent to a resistance

$$R_0 = \frac{1}{D\omega C} \quad (5)$$

which decreases with increasing frequency and causes even the parallel resistance to decrease rapidly beyond a certain frequency. That portion of the shunt capacitance C which is distributed causes a similar rapid decrease in resistance, even if its dielectric loss is negligible. These effects together are

Figure 2. General normalized curves of resistance as a function of frequency for a fixed resistor.

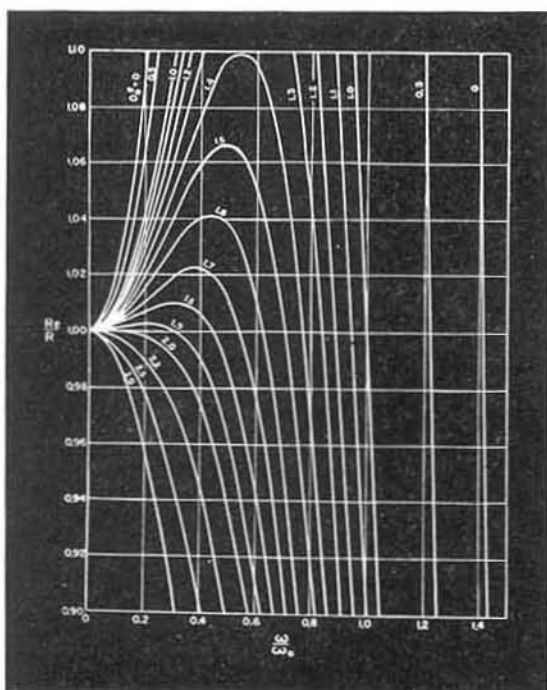

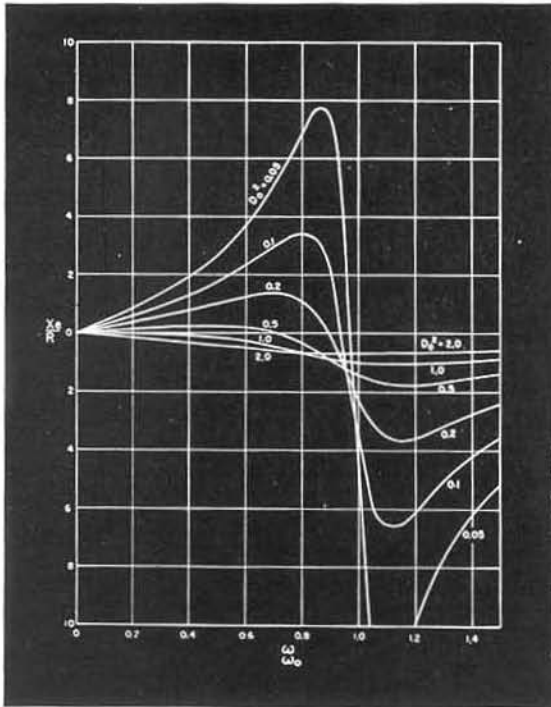

Figure 3. General normalized curves of reactance as a function of frequency for a fixed resistor.

called the Boella effect. Its outstanding characteristic is that, when the ratio of a-c to d-c resistance (normalized parallel resistance) is plotted against the product fR of frequency and d-c resistance, all points for any one type of resistor fall approximately on the same curve, regardless of the resistance value. The decrease in resistance will amount to 1% for wire-wound resistors and the poorer metallized resistors when the product fR is 0.01 (Mc, M Ω) and for the best metallized resistor when fR is 10 (Mc, M Ω).

For any given resistance value there will be a combination of residual parameters that will give best performance over the widest frequency range. Proper proportioning of the residual parameters determined by the mechanical construction will lead to the best compromise design for a line of fixed resistors. An example of this kind of design is the TYPE 663 Resistor, in which a fine, straight wire is used as the resistive element in order to reduce skin effect. The inductance is held at a low value by clamping the wire to flat metal fins, which also aid in power dissipation. This produces a comparatively large shunt capacitance, and the element is so proportioned that $\sqrt{\frac{L}{C}}$ is of the same order of magnitude as the resistance, a condition which minimizes the

changes of both inductance and capacitance with frequency. Resistors of this type exhibit only 1% change in resistance at frequencies as high as 30 megacycles.

Wire-wound resistors of the card type exhibit a negligible frequency error in resistance up to about 500 kc, for values of resistance up to 500 ohms, and only moderate errors at one megacycle.

When assembled into decades, these resistors have added to their own residual impedances those of the switches, wiring, and cabinet. The equivalent circuit is then that of Figure 4, which represents a single decade of the 510 type. For assemblies of such decades in the TYPE 602 Decade Resistance Boxes the same circuit is still valid. The incremental inductances of the several decades in the circuit are additive, but the capacitance is approximately that of highest decade in use. Typical values of the residual impedances for the various types of General Radio resistors are given in the specifications for each type.

It should be noted that the effect of the residual reactance depends greatly upon the way the resistor is connected into a circuit. Reactances can often be tuned out, particularly in parallel circuits. This is a particularly important consideration with the higher valued resistors of 10,000 ohms and above. When the resistor is used as a parallel circuit element, the upper limit of frequency for a given error is some 10 times higher than for the series connection.

All General Radio precision resistors in sizes above 100 ohms are wound with wire of a newly developed alloy which has many desirable characteristics. Chief among these are a smaller temperature coefficient of resistance than is found in older resistance alloys, and a negligible thermal emf. Moisture has no appreciable effect on its resistance, and there is little, if any, drift in resistance as a result of strains put in the wire when it is wound on a card. Its greater tensile strength is an advantage in winding, making it possible to produce better and more uniform resistors than can be made with other alloys.

Figure 4. Equivalent circuit of a resistance decade, showing location and nature of residual impedances.

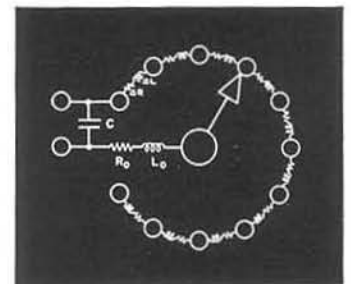

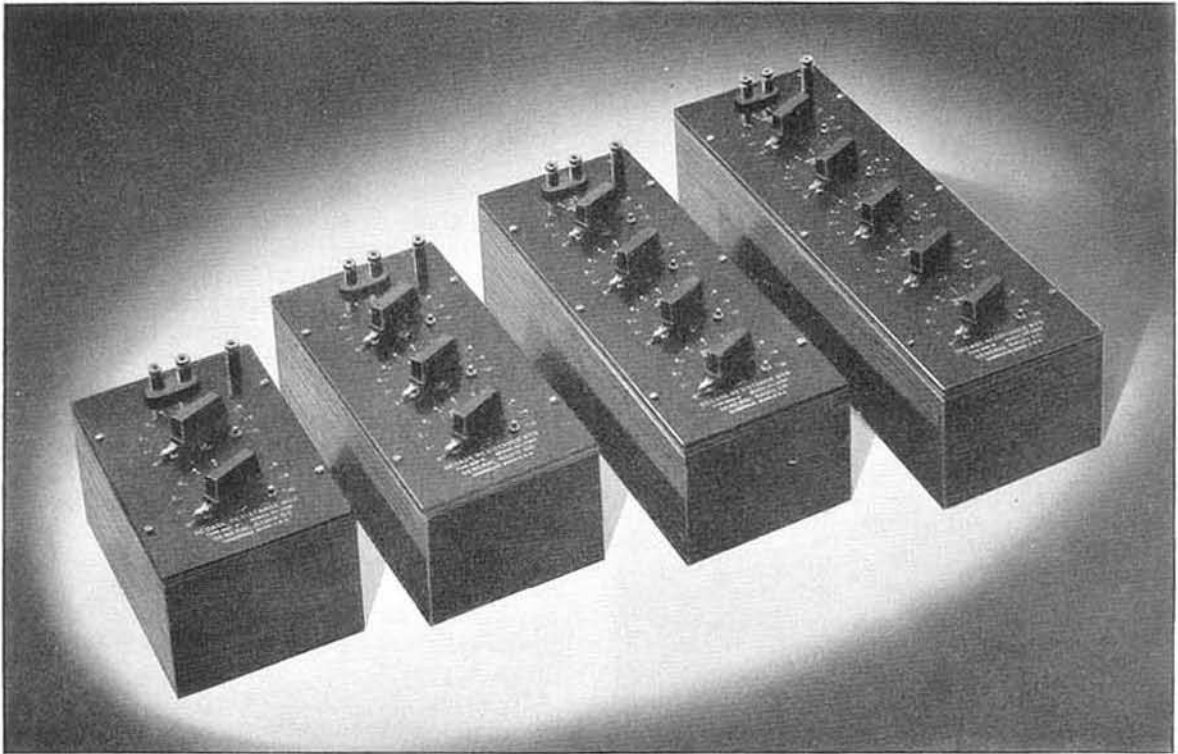

TYPE 602 DECADE-RESISTANCE BOX

USES: Accurate resistance boxes are extremely valuable wherever electrical measurements are made. Such boxes are constantly used in circuits where a wide range of resistance values is required or where variable dummy generator and load resistances are needed. The accuracy of TYPE 602 Decade-Resistance Boxes easily meets the requirements of these uses and also permits them to be used as laboratory standards and as ratio arms for direct- and alternating-current bridges.

Although designed primarily for direct-current and audio-frequency work, they are useful well into the radio-frequency range for many applications.

DESCRIPTION: The TYPE 602 Decade-Resistance Box is an assembly of two or more TYPE 510 Decade-Resistance Units in a single cabinet. Mechanical and electrical protection of the units is provided by the shielded walnut cabinet and aluminum panel, which completely enclose both the resistance units and switch contacts. The resistance elements have no electrical connection to the shield, which is brought out to a separate terminal connected to the panel.

Two-, three-, four-, and five-dial decade assemblies are available. Each decade has eleven contact studs and ten resistance units, so that the dial values overlap. A positive

detent mechanism assists in setting squarely on the contacts and so permits adjustments to be made without looking at the dials.

FEATURES: ▶ Zero resistance of TYPE 602 Decade-Resistance Boxes has been kept less than 0.003 ohm per decade by careful mechanical design.

▶ Individual resistance units are adjusted accurately to have their specified values at their own terminals, rather than at the terminals of the box. This adjustment is necessary for those types of measurement in which the difference between two settings of a resistance box is the significant value.

▶ Low-temperature-coefficient wire is used to wind all resistors. The characteristics of this wire also eliminate all difficulties caused by thermal emf in direct-current measurements.

▶ Residual inductances and capacitances are low and no serious frequency error exists in any box below 50 kc. Furthermore, the lower decades are also useful at higher frequencies, and detailed tabulations of the magnitudes of the residual impedances are given in the specifications.

▶ Engraved on each panel just above each decade switch knob is the maximum allowable current for each decade, based on a 40° Centigrade temperature rise.

SPECIFICATIONS

Frequency Characteristics: A TYPE 602 Decade-Resistance Box can be represented closely by the equivalent circuit below, which represents one decade of a box, with the remaining decades set to zero. R_0 and L_0 are the zero resistance and inductance of the box, due to the wiring and switches. These values are proportional to the number of decades in the box. ΔL is the inductance associated with each increment of resistance, ΔR . The effective capacitance C depends, in general, upon the dial setting, the variation being approximately linear with setting (the higher value is for the lowest setting). The values of the constants are tabulated below:

- L_0 = 0.10 μ h per dial
- R_0 (d-c) = 0.002 to 0.003 ohm per dial
- R_0 (1 Mc) = 0.04 ohm per dial; proportional to the square root of frequency at all frequencies above 100 kc.

| Type of Decade | 0.1-Ohm Step | 1-Ohm Step | 10-Ohm Step | 100-Ohm Step | 1000-Ohm Step | 10,000-Ohm Step |
|-----------------------|--------------|------------|-------------|--------------|---------------|-----------------|
| ΔR in ohms | 0.1 | 1.0 | 10 | 100 | 1000 | 10,000 |
| ΔL (μ h) | 0.014 | 0.05 | 0.11 | 0.29 | 3.3 | 9.5 |
| C† (μ mf) | — | 27 | 26-23 | 21-13 | — | — |

†The value of the capacitance shunting a single decade in a box depends upon the location of the decade in the box, as well as on the resistance of the decade. The values given here are for a TYPE 602-G and may be taken as representative.

If several decades of a box are in circuit at the same time, the incremental inductances of the several decades may be added directly, and the capacitance may be taken to be approximately that of the highest decade in use.

Zero Resistance: The direct-current zero resistance of the various boxes depends on the number of dials, as follows:

| No. of Dials | Zero Resistance |
|--------------|-----------------|
| 2 | 0.004-0.006 ohm |
| 3 | 0.006-0.009 ohm |
| 4 | 0.008-0.012 ohm |
| 5 | 0.010-0.015 ohm |

Temperature Coefficient: Less than $\pm 0.002\%$ per degree Centigrade at room temperatures, except for the 0.1 Ω decade, where the box wiring will affect the over-all temperature coefficient.

Type of Winding: See specifications for TYPE 510 Decade-Resistance Units, next page.

Accuracy of Adjustment: All cards are adjusted within 0.1% of the stated value between card terminals, except the 1-ohm cards which are adjusted within 0.25% and the 0.1-ohm units which are adjusted within 1%.

Maximum Current: See specifications for TYPE 510 Decade-Resistance Units, next page. Values for 40° Centigrade rise are engraved on panels directly above switch knobs.

Switches: Quadruple-leaf, phosphor-bronze brushes bear on contact studs $\frac{3}{8}$ inch in diameter. These brushes are bent so as not to be tangent to the arc of travel, thus avoiding cutting. A cam-type detent is provided. There are eleven contact points (0 to 10 inclusive).

Terminals: Jack-top binding posts set on General Radio standard $\frac{3}{4}$ -inch spacing for resistance connections. There is an extra post at the corner of the panel for connections to the shield.

Mounting: A copper-lined walnut cabinet, with aluminum panel, completely encloses switches and resistance units.

Dimensions: Panel length depends on the number of dials (see price list), being $7\frac{3}{4}$ for 2-dial, $10\frac{3}{8}$ for 3-dial, 13 for 4-dial, and $15\frac{3}{8}$ inches for 5-dial boxes. Panel width, 5 inches. Over-all height, 5 inches.

Net Weight: $3\frac{1}{4}$ for 2-dial, $4\frac{1}{4}$ for 3-dial, 5 for 4-dial, and $6\frac{1}{4}$ pounds for 5-dial boxes.

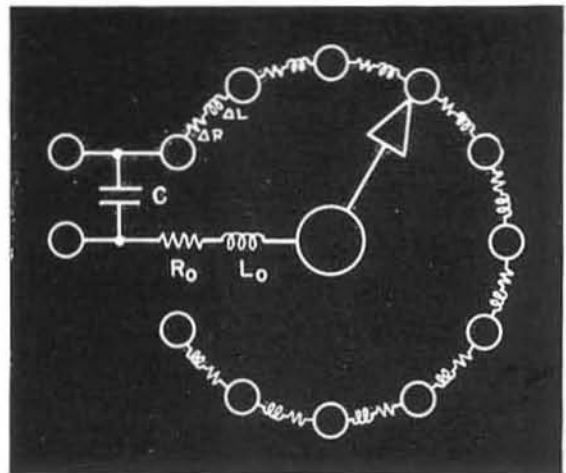

| Type | Resistance | No. of Dials | Type 510 Decades Used | Code Word | Price |
|-------|--|--------------|-----------------------|-----------|---------|
| 602-D | 11 ohms, total, in steps of 0.1 ohm | 2 | A, B | DECOY | \$32.00 |
| 602-F | 111 ohms, total, in steps of 0.1 ohm | 3 | A, B, C | DELTA | 46.00 |
| 602-G | 1,110 ohms, total, in steps of 1 ohm | 3 | B, C, D | DIGIT | 50.00 |
| 602-K | 1,111 ohms, total, in steps of 0.1 ohm | 4 | A, B, C, D | DEFER | 63.00 |
| 602-J | 11,110 ohms, total, in steps of 1 ohm | 4 | B, C, D, E | DEBIT | 68.00 |
| 602-N | 11,111 ohms, total, in steps of 0.1 ohm | 5 | A, B, C, D, E | DEMON | 83.00 |
| 602-L | 111,100 ohms, total, in steps of 10 ohms | 4 | C, D, E, F | DECAY | 73.00 |
| 602-M | 111,110 ohms, total, in steps of 1 ohm | 5 | B, C, D, E, F | DEMIT | 90.00 |

DECADE RESISTORS

TYPE 510 DECADE-RESISTANCE UNIT

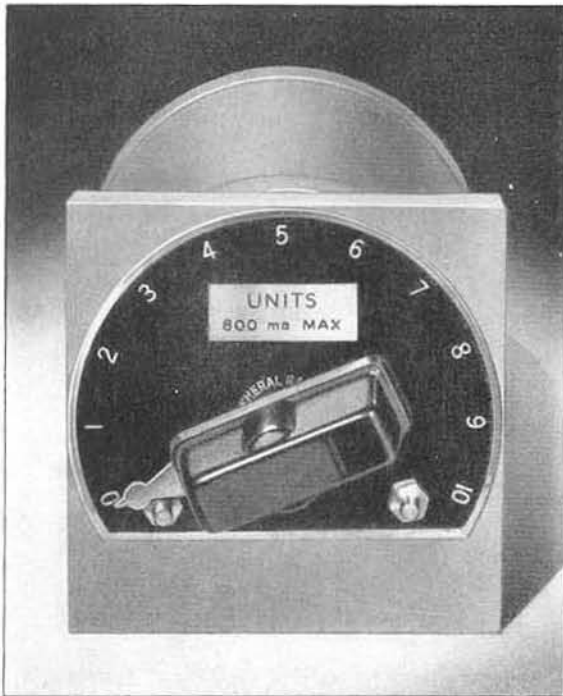

USES: Because of their precision, compactness, and sturdy construction the TYPE 510 Decade-Resistance Units are ideal for assembly into production test instruments, bridges, and other experimental and permanent equipment. They are particularly useful in applications where only a single decade is desired, or where a TYPE 602 Decade Box cannot be mounted conveniently. In many cases the use of these units will make available for general laboratory work relatively more expensive

decade-resistance boxes, otherwise tied up for long periods of time in experimental equipment.

DESCRIPTION: The 1-, 10-, and 100-ohm steps are Ayrton-Perry wound on molded phenolic forms especially shaped and heat treated to minimize ageing effects. The 0.1-ohm steps are bifilar wound with ribbon, while the 1000- and 10,000-ohm steps are unifilar wound on mica cards. The 100,000-ohm steps are wound in pies on ceramic spools.

Each decade is enclosed in an aluminum shield, and a knob and etched-metal dial plate are supplied. The mechanical assembly is also available complete with shield, blank dial plate, switch stops, and knob, but without resistors, as the TYPE 510-P3 Switch.

FEATURES: ▶ Each resistor is aged at a temperature of 135° Centigrade before being assembled into completed units. This ageing reduces to a negligible amount any subsequent drifting of resistance values.

▶ Frequency errors are negligible below 50 kilocycles, and complete information on each unit is tabulated in the specifications.

▶ Low-temperature-coefficient wire is used in all resistors. Difficulties due to thermal emf in direct-current measurements are eliminated in all of the units except the TYPE 510-G 100,000-ohm Decades. These are wound with Advance wire, and care should be taken in low-voltage direct-current work to see that temperature differences are kept at a minimum.

SPECIFICATIONS

Accuracy of Adjustment: Resistors are adjusted to be accurate at card terminals within the tolerances given in Table I on next page.

Maximum Current: See Table I on next page.

Type of Winding: See Table I on next page.

Frequency Characteristics: A TYPE 510 Decade-Resistance Unit can be represented closely by the equivalent circuit shown on page 27. The values of the constants, as determined by high-frequency bridge measurements, are listed in Table III.

In Table II is listed the maximum percentage change in effective series resistance of each decade as a function of frequency. For the TYPES 510-A and 510-B the error is due almost entirely to skin effect and is independent of switch setting. For the TYPE 510-C the error changes slowly with dial setting and is a maximum at maximum resistance setting. For the TYPE 510-D (100-ohm step decade) a broad maximum occurs at the 600-ohm setting, while for all the higher resistance units, the position of maximum frequency error is at the maximum resistance setting. For these latter decades (TYPES 510-E and -F)

the error is due almost entirely to shunt capacitance and is approximately proportional to the square of the resistance setting.

The high-resistance decades (TYPES 510-F and 510-G) are very commonly used as parallel resistance elements in measurement circuits, and so the error due to the shunt capacitance of the decades can frequently be eliminated. The remaining parallel resistance changes by only a fraction of the amount indicated in Table II as the series-resistance change. This fact is particularly important with reference to the TYPE 510-G which has 100,000-ohm steps. At maximum setting this unit has a -1% change in series resistance at 1 kilocycle, but its parallel resistance is changed by only -1% at 10 kilocycles.

Switches: Quadruple-leaf, phosphor-bronze brushes bear on contact studs $\frac{3}{8}$ inch in diameter. These brushes are bent so as not to be tangent to the arc of travel, thus avoiding cutting. A cam-type detent is provided. There are eleven contact points (0 to 10 inclusive). The switch resistance is between 0.002 and 0.003 ohm, and the

DECADE RESISTORS

effective capacitance of the switch is of the order of $5 \mu\text{mf}$, with a dissipation factor of 0.06 at 1 kilocycle. A molded phenolic switch form is used. The form for TYPE 510-G is molded from low-loss phenolic material.

Temperature Coefficient: The temperature coefficient of resistance is less than $\pm 0.002\%$ per degree Centigrade at room temperatures.

Terminals: Soldering lugs are provided.

Mounting: Each decade is complete with dial plate and knob and can be mounted on any panel between $\frac{3}{4}$ inch and $\frac{5}{8}$ inch in thickness. A template is furnished with each unit.

Dimensions: See sketch; shaft diameter is $\frac{3}{16}$ inch.

Net Weight: TYPE 510 Units, 11 ounces; TYPE 510-P3, $9\frac{1}{2}$ ounces.

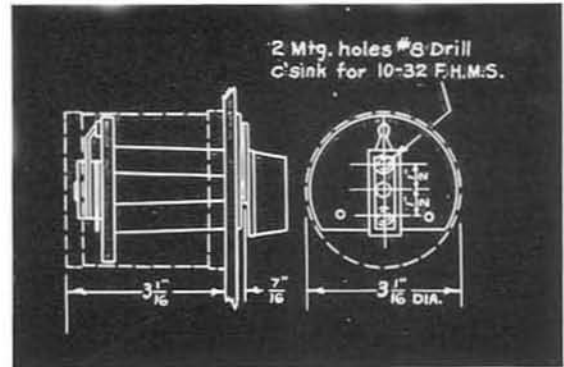

TABLE I

| Type | Resistance per Step | Accuracy | Type of Winding | Maximum Current | | Maximum Power per Step |
|-------|---------------------|--------------|------------------|-----------------|-------------|------------------------|
| | | | | 20° C. Rise | 40° C. Rise | 40° C. Rise |
| 510-A | 0.1 Ω | $\pm 1.0\%$ | Bifilar | 1 a | 1.6 a | 0.25 watt |
| 510-B | 1 Ω | $\pm 0.25\%$ | Ayrton-Perry | 550 ma | 800 ma | 0.6 watt |
| 510-C | 10 Ω | $\pm 0.1\%$ | Ayrton-Perry | 170 ma | 250 ma | 0.6 watt |
| 510-D | 100 Ω | $\pm 0.1\%$ | Ayrton-Perry | 55 ma | 80 ma | 0.6 watt |
| 510-E | 1000 Ω | $\pm 0.1\%$ | Unifilar on Mica | 16 ma | 23 ma | 0.5 watt |
| 510-F | 10,000 Ω | $\pm 0.1\%$ | Unifilar on Mica | 5 ma | 7 ma | 0.5 watt |
| 510-G | 100,000 Ω | $\pm 0.1\%$ | Pies | 1.5 ma | 2.5 ma | 0.6 watt |

TABLE II

Maximum Percentage Change in Series Resistance as a Function of Frequency
Frequency in kc

| Decade | 50 kc | 100 kc | 200 kc | 500 kc | 1000 kc | 2000 kc | 5000 kc |
|------------------|-------|--------|--------|--------|---------|---------|---------|
| 0.1-ohm steps | — | — | — | — | 0.1% | 0.8% | 5% |
| 1.0-ohm steps | — | — | — | 0.1% | 0.5% | 1.5% | 9% |
| 10-ohm steps | — | — | — | — | 0.1% | 0.2% | 1.5% |
| 100-ohm steps | — | — | — | — | 0.1% | 0.2% | 0.9% |
| 1000-ohm steps | — | -0.1% | -0.3% | -1.5% | -6.5% | — | — |
| 10,000-ohm steps | -2% | -8% | — | — | — | — | — |

TABLE III

Value of Constants for the Equivalent Circuit of a TYPE 510 Decade-Resistance Unit
(See diagram on page 27)

| Type of Decade | ΔR Ohms | ΔL μh | L_0 μh | C^* μmf |
|----------------|--------------------|-----------------------------|------------------------|-------------------------|
| 510-A | 0.1 | 0.014 | 0.023 | 7.7-4.5 |
| 510-B | 1.0 | 0.056 | 0.023 | 7.7-4.5 |
| 510-C | 10.0 | 0.11 | 0.023 | 7.7-4.5 |
| 510-D | 100 | 0.29 | 0.023 | 7.7-4.5 |
| 510-E | 1000 | 3.3 | 0.023 | 7.7-4.5 |
| 510-F | 10,000 | 9.5 | 0.023 | 7.7-4.5 |
| 510-G | 100,000 | — | 0.023 | 7.7-4.5 |

*The larger capacitance occurs at the lowest setting of the decade. The values given are for units without the shield cans in place. With the shield cans in place, the shunt capacitance is from 10 to 20 μmf greater than indicated here, depending on whether the shield is tied to the switch or to the zero end of the decade.

| Type | Resistance | | Code Word | Price |
|---------------|----------------|--------------|-----------|---------|
| | Total | Per Step | | |
| 510-A | 1 ohm | 0.1 ohm | ELATE | \$10.00 |
| 510-B | 10 ohms | 1 ohm | ELDER | 12.00 |
| 510-C | 100 ohms | 10 ohms | ELEGY | 12.00 |
| 510-D | 1,000 ohms | 100 ohms | ELBOW | 14.00 |
| 510-E | 10,000 ohms | 1,000 ohms | ELECT | 15.00 |
| 510-F | 100,000 ohms | 10,000 ohms | ELVAN | 17.50 |
| 510-G | 1,000,000 ohms | 100,000 ohms | ENTER | 44.00 |
| 510-P3 Switch | — | — | ENVOY | 6.50 |



TYPE 670-F COMPENSATED DECADE RESISTOR

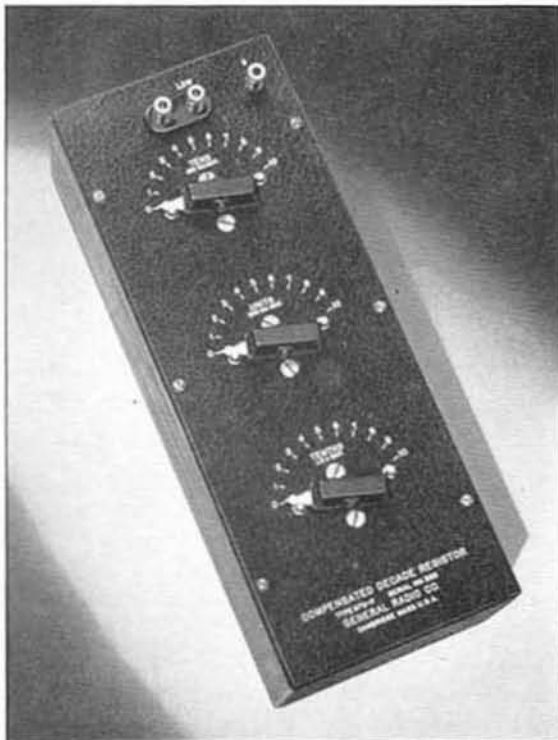

USES: The TYPE 670-F Compensated Decade Resistor is intended for use in a-c impedance measurements where non-reactive increments of resistance are desired. This type of decade resistor made possible the development of the first precision radio-frequency bridge. It is also used in the TYPE 667-A Inductance Bridge and is an important factor in determining the accuracy and convenience of operation of that bridge. Compensated decade resistors are useful in tuned-circuit substitution measurements,

as variable resistance elements in antenna measuring circuits, and, in general, for bridge measurements wherever the variation in inductance of the conventional type of decade resistor cannot be tolerated.

DESCRIPTION: The TYPE 670-F Compensated Decade Resistor is an assembly of TYPE 668 Compensated Decade-Resistance Units.

The decade-resistance units use a double card system, as shown on page 32, and the switch is so arranged that a copper coil is substituted when a resistance coil is switched out of circuit. The inductance of the copper coil is equal to the inductance of the resistance coil, but its resistance is very small. Consequently, as the position of the switch is changed, the inductance of the decade is kept constant, and only the resistance is varied.

The decade units are mounted on a black crackle-finished aluminum panel and encased in a walnut cabinet, lined with sheet copper. The copper lining, together with the aluminum panel, forms a complete shield for the resistors. A separate terminal is provided so that independent connection to this shield may be made.

FEATURES: ▶ Inductance remains constant within 0.1 microhenry regardless of resistance setting of the TYPE 670-F Compensated Decade Resistor.

▶ Total inductance is only about one microhenry and can usually be balanced out in preliminary adjustment.

▶ The high accuracy and low temperature coefficient of resistance of the TYPE 602 Boxes are also maintained in the TYPE 670-F Resistor.

▶ Maximum current values, based on a 40° Centigrade temperature rise, are engraved on the panel.

SPECIFICATIONS

Type of Winding: The 10-ohm and 1-ohm steps are Ayrton-Perry resistance cards, while the 0.1-ohm steps are bifilar ribbon units.

All decades are compensated by copper coils as shown in the diagram on page 32.

Accuracy of Adjustment: Resistance increments are correct within $\pm 0.1\%$ for the 10-ohm steps, $\pm 0.25\%$ for the 1-ohm steps, and $\pm 1\%$ for the 0.1-ohm steps.

Zero Resistance: The direct-current zero resistance is about 0.04 ohm. The zero resistance at 1 Mc is about 0.3 ohm and at frequencies above 100 kc is proportional to the square root of the frequency.

Inductance: The zero inductance is 1.05 microhenry. This value remains constant within 0.1 microhenry regardless of resistance setting.

Switches: Double-leaf, phosphor-bronze brushes bear on contact studs $\frac{1}{4}$ inch in diameter. These brushes are bent so as not to be tangent to the arc of travel, thus avoid-

ing cutting. A cam-type detent is provided, and there are eleven contact points (0 to 10 inclusive).

Terminals: Standard $\frac{3}{4}$ -inch spacing is used on the terminals. A ground post connected to shield and panel is also provided.

Maximum Current: See specifications for TYPE 668 Compensated Decade-Resistance Unit on page 32. Values for 40° Centigrade rise are engraved on the panel directly above the switch knobs.

Frequency Characteristics: The frequency characteristics of the TYPE 670 Compensated Decade Resistor are similar to those of the TYPE 668 Units which are used in the boxes. However, the box wiring and cabinet shield affect these characteristics by adding series inductance and shunt capacitance.

Temperature Coefficient: Less than $\pm 0.002\%$ per degree Centigrade at room temperatures, except at the lower settings where the temperature coefficient of the

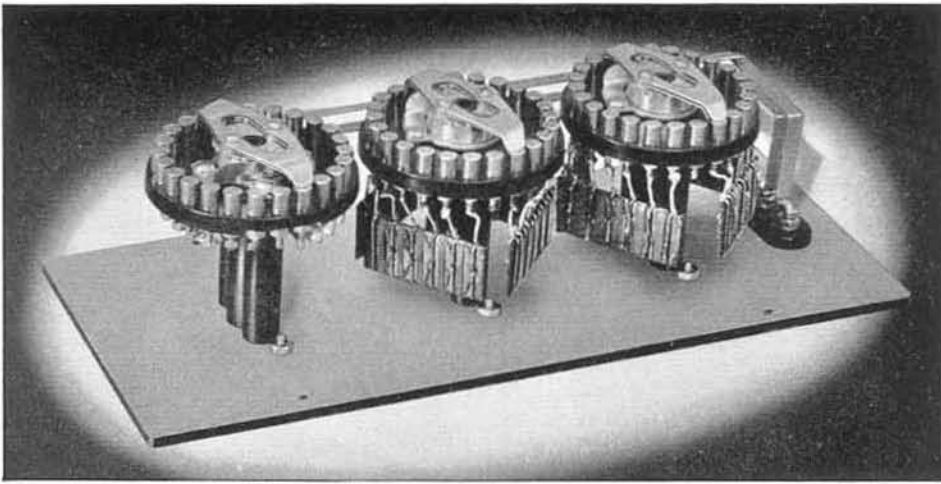

Interior of TYPE 670-F Compensated Decade Resistor.

copper compensating windings may affect the over-all temperature coefficient.

Mounting: The dials are mounted on aluminum panels in copper-lined walnut cabinets.

Dimensions: Panel, (length) 13 x (width) 5 inches. Cabinet, (height) 5 inches, over-all.

Net Weight: 5½ pounds.

| Type | Resistance | Type Units Used | Code Word | Price |
|-------|---|-----------------|-----------|---------|
| 670-F | 0 to 111 ohms, total, in steps of 0.1 ohm | 668-A, -B, -C | ABYSS | \$60.00 |

TYPE 668 COMPENSATED DECADE-RESISTANCE UNIT

USES: The TYPE 668 Compensated Decade-Resistance Unit is the basic unit for the TYPE 670-F Compensated Decade Resistor. In addition, it has found wide application as a component part for building into experimental or permanent measuring equipment for use at radio frequencies. It has been built into antenna measuring equipment as well as into general r-f impedance-measuring circuits. It is useful for any measurements where constancy of inductance is desired as resistance is varied.

DESCRIPTION: The TYPE 668 Compensated Decade-Resistance Unit is made with a double set of switch contacts, by means of which a copper winding is exchanged, step by step, for the resistance cards, thus keeping the total inductance constant regardless of resistance setting. This arrangement is shown in the diagram on the next page.

The units are mounted with an etched-metal dial plate, knob, and stops, but with no shield.

FEATURES: ▶ Total inductance of the TYPE 668 Compensated Decade-Resistance Unit has been kept to a few tenths of a microhenry. This value remains constant within 0.05 microhenry, regardless of resistance setting.

▶ Frequency errors have been kept small by careful construction, and so all models are useful up to several megacycles.

▶ The TYPE 668 Units are accurately adjusted resistors with a low temperature coefficient of resistance.

▶ Since it is difficult to construct a decade assembly of resistors with no net inductive reactance, the next best condition is a unit with a low but constant inductance.

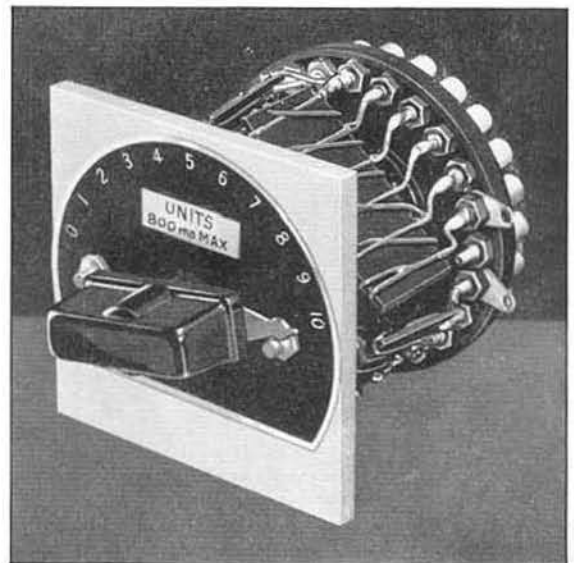

DECADE RESISTORS

SPECIFICATIONS

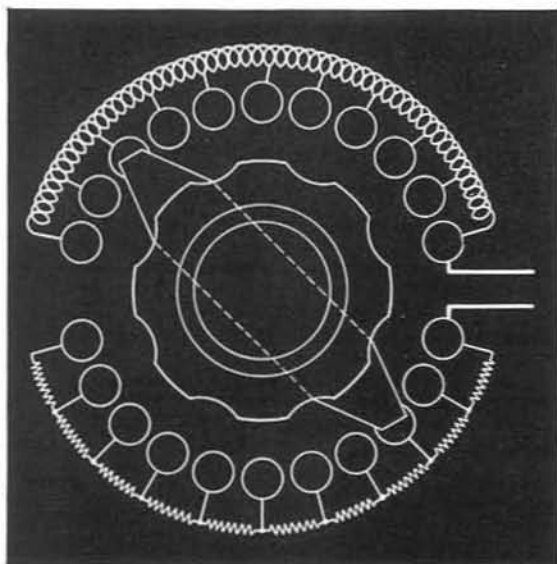

The construction of the compensated decade resistance is shown above. Opposite ends of the switch blade make contact with resistance or inductance windings, respectively. As a resistance step is added to the circuit, a compensating inductance step is removed, and vice versa.

Accuracy of Adjustment: Resistance increments are correct within $\pm 1\%$ for the 0.1-ohm steps, $\pm 0.25\%$ for the 1-ohm steps, and $\pm 0.1\%$ for the 10-ohm steps.

Zero Resistance: The direct-current zero resistance of the different units is given in Table I. The zero resistance at 1 Mc is about 8 times that at dc and at frequencies above 100 kc is proportional to the square root of the frequency.

TABLE I

| Type | Zero Resistance | Inductance |
|-------|-----------------|-----------------|
| 668-A | 0.001-0.010 ohm | 0.15 microhenry |
| 668-B | 0.015-0.025 ohm | 0.30 microhenry |
| 668-C | 0.010-0.020 ohm | 0.50 microhenry |

Inductance: The inductance of the different units is given in the table above. The inductance remains constant regardless of resistance setting within 0.05 microhenry.

Temperature Coefficient: The temperature coefficient of resistance is less than $\pm 0.002\%$ per degree Cen-

tigrade at room temperatures, except for the lower settings of Types 668-A and 668-B, where the temperature coefficient of the compensating windings may affect the over-all temperature coefficient.

Frequency Characteristics: The frequency characteristics of Type 668 Compensated Decade-Resistance Units are similar to those of Type 510 Decade-Resistance Units, page 28. Because 10-ohm cards are the largest used, the effects of shunt capacitance are entirely negligible, and the change in resistance with frequency results almost entirely from skin effect.

Although skin effect produces a positive change in resistance, the skin effect in the compensating winding is greater than that in the resistance cards. Accordingly there is a net negative change in resistance increments from this effect. That is, the increment in resistance between one switch point and the next higher one will be less at high frequencies than at low. This "negative skin effect," at one megacycle, is about -0.8% for the units decade and about -0.6% for the tens decade.

Maximum Current: The following table gives the allowable current for the different units. The values of current for a 40° Centigrade temperature rise, based on one-quarter watt dissipation per resistor, are engraved on the dial plate.

TABLE II

| Type | Current for 20° C. Rise | Current for 40° C. Rise |
|-------|--------------------------------|--------------------------------|
| 668-A | 1.0 a | 1.6 a |
| 668-B | 300 ma | 500 ma |
| 668-C | 100 ma | 160 ma |

Type of Winding: The 10-ohm and 1-ohm cards are Ayrton-Perry wound, while the 0.1-ohm steps are bifilar ribbon. Compensating windings are used on all decades to maintain constant inductance. (See diagram above.)

Switch: Double-leaf, phosphor-bronze brushes bear on contact studs $\frac{1}{4}$ inch in diameter. These brushes are bent so as not to be tangent to the arc of travel, thus avoiding cutting. A cam-type detent is provided and there are eleven contact points (0 to 10 inclusive).

Terminals: Soldering lugs are provided.

Mounting: Interchangeable (except for switch stops) with Type 510 (see page 29). A combination dial plate and drilling template is furnished. Machine screws for attaching the decades to a panel are supplied.

Dimensions: Diameter, $3\frac{1}{8}$ inches; depth behind panel, 3 inches, over-all; shaft diameter, $\frac{3}{8}$ inch.

Net Weight: 7 ounces.

| Type | Resistance | | Code Word | Price |
|-------|------------|----------|-----------|---------|
| | Total | Per Step | | |
| 668-A | 1 ohm | 0.1 ohm | GABLE | \$13.50 |
| 668-B | 10 ohms | 1 ohm | GAILY | 16.00 |
| 668-C | 100 ohms | 10 ohms | GALOP | 16.00 |



TYPE 654-A DECADE VOLTAGE DIVIDER



USES: The TYPE 654-A Decade Voltage Divider will supply exact voltage ratios between 0.001 and 1.000 in steps of 0.001, and so is useful on the input of amplifiers and similar high-impedance circuits for reducing the input voltage by a definitely known ratio which can be varied in very small steps.

DESCRIPTION: This instrument is equivalent to a pair of TYPE 602 Decade-Resistance Boxes connected in series and so manipulated that as resistance is taken out of one box it is added to the other to maintain the total resistance constant at 10,000 ohms. This action is accomplished by using five TYPE 510 Decade-

Resistance Units, two of which are connected back-to-back to two similar units by means of a chain drive.

FEATURES: The TYPE 654-A Decade Voltage Divider covers a very wide range of voltage ratios. It is possible to obtain 1000 different ratios from 0.001 to 1.000, and each one is known within $\pm 0.2\%$. The input resistance remains constant regardless of dial settings, and so reaction on the input voltage is eliminated. All resistors are wound with an alloy wire of such characteristics that no difficulty due to thermal emf will be encountered in direct-current measurements.

SPECIFICATIONS

Range: Voltage ratios from 0.001 to 1.000 in steps of 0.001 can be obtained by setting up the desired value on the three switches.

Accuracy: Each individual resistor is adjusted within $\pm 0.1\%$, so the error in voltage ratio is never greater than $\pm 0.2\%$.

Frequency Characteristics: If the external capacitance which is placed across the output terminals is less than 20 μmf , the frequency error is less than 0.1% for all frequencies below 10,000 cycles.

Input Impedance: The input impedance is a constant resistance of 10,000 ohms, regardless of the ratio setting. This value is engraved on the panel.

Output Impedance: The output impedance of the voltage divider varies from 10 ohms to 10,000 ohms, depending upon the settings. The divider is accurate only when the impedance connected to it is at least 1000 times the internal output impedance.

Maximum Voltage: The maximum allowable input voltage for a 40° Centigrade temperature rise is 230 volts. This value is engraved on the panel.

Temperature Coefficient: The temperature coefficient of the resistors is less than $\pm 0.002\%$ per degree Centigrade at normal room temperatures.

Terminals: Jack-clip binding posts are provided and standard $\frac{3}{4}$ -inch spacing is used. The shield is connected to one terminal of both input and output which is marked G.

Mounting: The decades are mounted on an aluminum panel which is enclosed in a shielded walnut cabinet.

Dimensions: Panel, (length) 13 x (width) 7 inches. Cabinet, (depth) $5\frac{1}{4}$ inches, over-all.

Net Weight: 8 pounds.

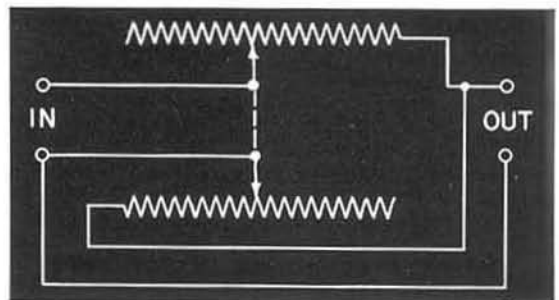

| Type | Code Word | Price |
|--------------------------------------|-----------|----------|
| 654-A Decade Voltage Divider | ABACK | \$100.00 |

ATTENUATORS

TYPE 1450 DECADE ATTENUATOR



USES: The TYPE 1450 Decade Attenuator is useful in power-level measurements, transmission-efficiency tests, and in gain or loss measurements on transformers, filters, amplifiers and similar equipment. It can also be used as a power-level control in circuits not equipped with other volume controls.

DESCRIPTION: The TYPE 1450 Decade Attenuator is an assembly of two or three TYPE 829 Decade Attenuator Units mounted on a single panel and housed in a metal cabinet. Each decade has eleven positions, 0 to 10 inclusive, so the decades overlap.

FEATURES: ▶ A wide range of attenuation values is possible in small steps.

▶ The accuracy of the boxes is maintained even at low radio frequencies.

▶ Decade-type switches make the boxes convenient to use. There are no stops on the 0.1- and 1-db-per-step decades, facilitating quick return from full to zero attenuation when making adjustments.

▶ Both T-type sections and balanced-H sections are available.

▶ An etched plate is provided, indicating mismatch loss when used with impedances other than 600 ohms.

SPECIFICATIONS

Attenuation Range: 110 or 111 decibels in steps of 1 or 0.1 decibel, respectively.

Terminal Impedance: 600 ohms in either direction.

Accuracy: Each individual resistor is adjusted within $\pm 0.25\%$ of its correct value. The error in attenuation is less than $\pm 1\%$ of the indicated value, provided the attenuator is terminated by a pure resistance.

Frequency Error: At frequencies below 200 kc the total error in attenuation will not be greater than $\pm 1\%$ of the indicated value.

Type of Section: T or balanced-H. Properly terminated, both types present a constant impedance in both directions, but the balanced-H should be used where both sides of the circuit must be balanced to ground.

Type of Winding: See TYPE 829 on next page.

Maximum Input Power: 1 watt.

Switches: See TYPE 829 on next page. Stops are provided on the highest decade only (10 db per step).

Mounting: The decade units are mounted on an aluminum panel in a metal cabinet. Each decade is individually shielded, and all shields are connected to the panel and the "G" terminal. Relay-rack mounting is available at an additional charge on special order.

Terminals: Jack-top binding posts with $\frac{3}{4}$ -inch spacing; common terminal of T units grounded to chassis; common terminal of H units not grounded.

Dimensions: 1450-HA and 1450-TA, 10 x $5\frac{3}{4}$ x 12 $\frac{1}{4}$ inches over-all. 1450-HB and 1450-TB, 12 x $5\frac{3}{4}$ x 12 $\frac{1}{4}$ inches over-all.

Net Weight: 1450-HA and 1450-TA, 10 $\frac{3}{4}$ pounds; 1450-HB and 1450-TB, 15 $\frac{1}{2}$ pounds.

| Type | Range | Impedance | Type of Section | Code Word | Price |
|---------|-------------------------------|-----------|-----------------|------------|------------------------|
| 1450-HA | 110 db in steps of 1 db . . . | 600 ohms | Balanced-H | NETWORKHAT | Price on Request |
| 1450-TA | 110 db in steps of 1 db . . . | 600 ohms | T | NETWORKTAM | |
| 1450-HB | 111 db in steps of 0.1 db | 600 ohms | Balanced-H | NETWORKHUB | |
| 1450-TB | 111 db in steps of 0.1 db | 600 ohms | T | NETWORKTUB | |

TYPE 829 DECADE ATTENUATOR UNITS

USES: These decade units have been designed as convenient attenuators which can be built into speech circuits, recording channels or other equipment where definitely known amounts of attenuation are required. They provide, for attenuation, the analogue of decade resistors for resistance. The tapered units are useful for changing impedance levels either up or down.

DESCRIPTION: The resistors used in each decade are mounted in compartments in a cast aluminum housing, which is completely shielded by the addition of aluminum covers. Each decade consists of four pads series-connected by cam-operated switches, arranged with positive detents. All cams are mounted on a control shaft which is provided with ball bearings. Each pad is completely



shielded, and a shield is interposed between the input and output elements of each pad.

FEATURES: ▶ Accurately known attenuation over a wide frequency range is possible because of careful shielding, the construction of the resistance cards, and the use of capacitance compensation.

▶ Decade-type switches which can be arranged for continuous rotation make the TYPE S29 Decade Attenuator Unit very convenient to use.

▶ Tapered units for changing impedance levels are also available in both T and balanced-H sections.

SPECIFICATIONS

Attenuation Range: Three decade ranges are listed in the price table below. The two tapered units, TYPES S29-HT and S29-TT, identical in appearance, have a five point switch and introduce an exact insertion loss, depending upon the matching ratio (either end can be used as input), as follows:

| | | | | | |
|----------------|--------------|--------------|-------------|-------------|-------------|
| Matching Ratio | 600Ω to 600Ω | 150Ω to 600Ω | 75Ω to 600Ω | 50Ω to 600Ω | 30Ω to 600Ω |
| Attenuation... | 0db | 12db | 15db | 17db | 20db |

Characteristic Impedance: 600 ohms both directions except for the tapered units which are 600 ohms in one direction and either 30, 50, 75, 150, or 600 ohms in the other direction to accommodate microphones, coaxial lines, high-fidelity telephone lines, etc. Either end can be used as input.

Accuracy: Each individual resistor is adjusted within ±0.25% of its correct value. The error in attenuation is less than ±1% of the indicated value, provided the attenuator is terminated by a pure resistance.

Frequency Error: At frequencies below 1 Mc the total error in attenuation will not be greater than ±1% of the indicated value.

Type of Section: Both balanced-H and T-type sections are available.

Type of Winding: All resistance elements use Ayrton-Perry windings except the shunt elements of S29-HA and S29-TA which are unifilar cylindrical windings. Where necessary resistors are capacitance-compensated.

Maximum Input Power: 1 watt.

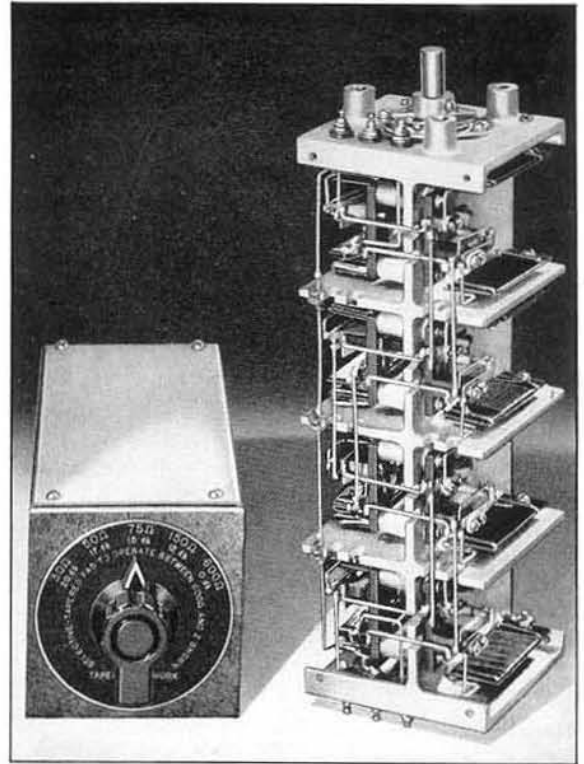

(Left) TYPE S29-HT Decade Attenuator Unit (tapered model), and (Right) typical internal construction of the TYPE S29 Decade Attenuator Units.

Switches: Cam-type switches are used with twelve positions covering 360°. The dials are numbered from "0" to "10" inclusive (except on tapered models) and the twelfth point is also connected to "0." No stops are provided in the switch mechanism to prevent complete rotation, but spacers, which are provided, can be used under the mounting screws to act as stops for the knob.

Terminals: External input and output soldering terminals on opposite ends; common terminal of T units grounded to chassis; common terminal of H units not grounded.

Mounting: The resistors and switches are housed in compartments of an aluminum casting, which is enclosed by aluminum covers. A dial and knob are furnished, and decades may be panel mounted from one end by three mounting screws which are provided.

Dimensions: 3 1/8 x 3 1/8 inches, extending 9 1/2 inches back of panel.

Net Weight: 3 1/4 pounds.

| Type | Range | Type of Section | Code Word | Price |
|--------|------------------------------------|-----------------|------------|------------------------|
| 829-HA | 1db in steps of 0.1 db | Balanced-H | TENUTORHAG | Price on Request |
| 829-HB | 10 db in steps of 1 db | Balanced-H | TENUTORHUB | |
| 829-HC | 100 db in steps of 10 db | Balanced-H | TENUTORHIC | |
| 829-HT | (See Specifications above) | Balanced-H | TENUTORHUT | |
| 829-TA | 1 db in steps of 0.1 db | T | TENUTORTAD | |
| 829-TB | 10 db in steps of 1 db | T | TENUTORTUB | |
| 829-TC | 100 db in steps of 10 db | T | TENUTORTIC | |
| 829-TT | (See Specifications above) | T | TENUTORTOT | |

FIXED RESISTORS

TYPE 663 RESISTOR

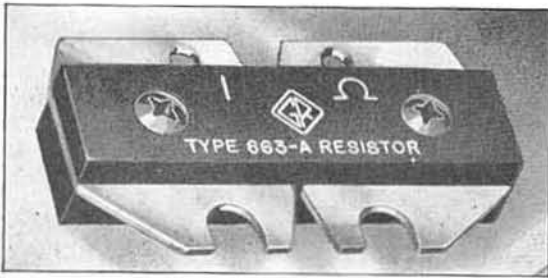

USES: The TYPE 663 is designed to have an accurately known impedance at high frequencies. It is particularly useful as a standard resistor for the resistance-variation method of impedance measurement at radio frequencies and as a circuit element in bridges and similar equipment. It is also useful as a terminating resistor for matching radio-frequency transmission lines and, generally, as a

low-resistance standard in high-frequency applications.

DESCRIPTION: A straight piece of resistance wire is soldered to two flat metal plates, which are mounted close together on a strip of insulating material. A thin piece of mica insulates the wire from the plates, except at the soldered ends. This assembly is rigidly clamped together with a top piece of insulating material.

FEATURES: ▶ Very small residual inductance as a result of the shielding effect of the current flow in the flat metal plates upon which the resistance wire is clamped.

▶ Skin effect is kept at a minimum and $\sqrt{L/C}$ is maintained at a value that minimizes the residual reactance as well as resistance change with frequency.

▶ Power dissipation is greatly increased by the terminal fins.

SPECIFICATIONS

Resistance Values: Standard units are available in the following resistances: 1, 2, 5, 10, 20, 50, and 100 ohms.

Accuracy: All units are adjusted within $\pm 1\%$.

Residual Parameters: The table below gives approximate values for L for the different units.

Skin Effect: For all units the skin effect is less than 1% for frequencies below 50 megacycles.

Temperature Coefficient: At normal room temperature the temperature coefficient is less than $\pm 0.002\%$ per degree Centigrade.

Maximum Power and Current: The allowable power

dissipation for a 40° Centigrade temperature rise varies with resistance, being 2 watts for the 1-ohm unit and 0.4 watt for the 100-ohm unit. The rated current for this temperature rise for the different units is given in the table.

Terminals: The flat metal plates to which the resistance wire is attached are used as terminals, and are both slotted and drilled for convenience in mounting.

Dimensions: (Length) $2\frac{1}{4}$ x (width) $1\frac{1}{4}$ inches. Over-all height $\frac{5}{8}$ inch.

Net Weight: 2 ounces.

| Type | Resistance | L | Current for 40°C. Rise | Code Word | Price |
|-------|------------|----------------|------------------------|-----------|--------|
| 663-A | 1 ohm | 0.0065 μ h | 1.4 a | PANIC | \$7.50 |
| 663-B | 2 ohms | 0.013 μ h | 1.0 a | PARTY | 7.50 |
| 663-C | 5 ohms | 0.015 μ h | 0.5 a | PATTY | 7.50 |
| 663-D | 10 ohms | 0.029 μ h | 0.35 a | PEDAL | 7.50 |
| 663-E | 20 ohms | 0.032 μ h | 0.2 a | PENAL | 7.50 |
| 663-F | 50 ohms | 0.034 μ h | 0.1 a | PENNY | 7.50 |
| 663-G | 100 ohms | 0.039 μ h | 0.06 a | PETTY | 7.50 |

Ratio of effective resistance, and equivalent series reactance, to d-c resistance versus frequency, for the TYPE 663 Resistors mounted on TYPE 138-VD Binding Posts and TYPE 274-Y Panel Terminal Insulators $\frac{3}{8}$ inch above a $\frac{1}{4}$ -inch metal panel. One end was grounded to the panel and the total capacitance approximated the rather high value of 6.5 μ mf, which could have been reduced if a low-capacitance mounting were used.

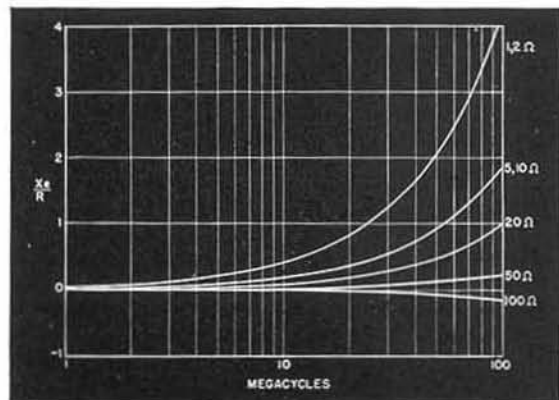
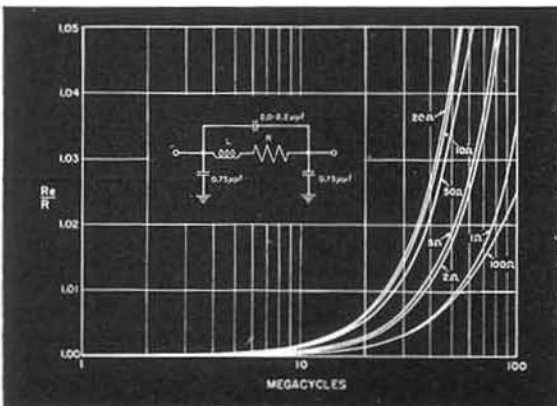

TYPE 500 RESISTOR

USES: The TYPE 500 Resistors are particularly recommended as resistance standards for use in impedance bridges. They are also valuable as secondary standards for laboratory use. The plug-type terminals make them convenient as terminating impedances for attenuation boxes, lines, and similar circuits and as circuit elements in either experimental or permanent equipment.

DESCRIPTION: This resistor is an accurately adjusted resistance card, sealed in a phenolic case. Both screw-type and plug-type terminals are provided.

FEATURES: ▶ Convenience and accuracy are combined in the TYPE 500 Resistors.

▶ All resistors are wound with an alloy wire chosen so that no difficulty due to thermal emf will be encountered in direct-current work.

▶ Low temperature coefficient of resistance and excellent high-frequency characteristics

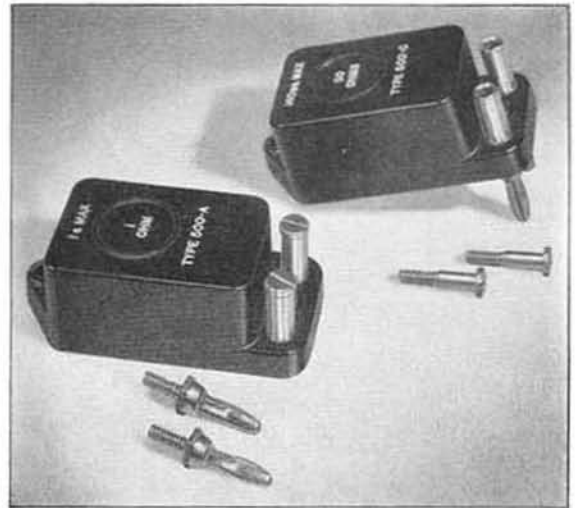

make these resistors suitable for a wide variety of applications.

SPECIFICATIONS

Resistance: Twelve standard values are tabulated below. Other values can be built to special order.

Accuracy of Adjustment: Each resistor is adjusted within $\pm 0.1\%$ of its stated value at the terminals of the unit, except the 1-ohm unit which is adjusted within $\pm 0.25\%$.

Frequency Characteristics: The table given on page 29 for the TYPE 510 Decade-Resistance Unit represents the behavior of the TYPE 500 Resistors rather accurately, particularly for the lower resistance units (up to 600 ohms). For the higher-resistance units the errors are less than those tabulated for the TYPE 510, because of the relatively small shunt capacitance of an isolated resistor.

Maximum Power and Current: All units will dissipate one watt for a temperature rise of 40° Centigrade. The value of current for this rise is given in the table below and is engraved on each unit.

Temperature Coefficient: At normal room temperature, the temperature coefficient of resistance is less than $\pm 0.002\%$ per degree Centigrade.

Type of Winding: For resistance of less than 200 ohms Ayrton-Perry windings are used; for 200 ohms and higher values of resistance the winding is unifilar on mica cards.

Terminals: Both terminal screws and plugs are supplied, and both can be used. Each terminal stud is recessed as a jack to accommodate a plug. Standard $\frac{3}{4}$ -inch spacing is used.

Mounting: Each resistor is sealed in a case of black molded phenolic with an impregnating wax. Two mounting holes are provided.

Dimensions: (Length) $2\frac{3}{4}$ x (width) $1\frac{5}{16}$ inches. Overall height, exclusive of plugs, 1 inch.

Net Weight: 2 ounces.

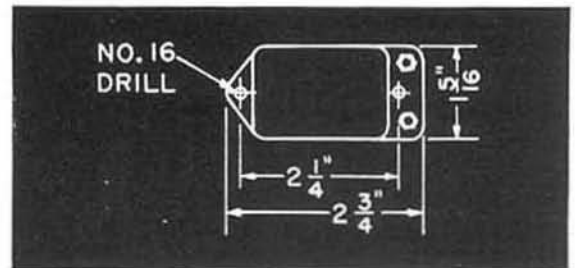

| Type | Resistance | Maximum Current | Code Word | Price |
|-------|-------------|-----------------|------------|--------|
| 500-A | 1 ohm | 1.0 a | RESISTBIRD | \$3.00 |
| 500-B | 10 ohms | 310 ma | RESISTDESK | 3.00 |
| 500-K | 20 ohms | 220 ma | RESISTFILM | 3.00 |
| 500-C | 50 ohms | 140 ma | RESISTFORD | 3.00 |
| 500-D | 100 ohms | 100 ma | RESISTFROG | 3.00 |
| 500-E | 200 ohms | 70 ma | RESISTGIRL | 3.00 |
| 500-F | 500 ohms | 45 ma | RESISTGOAT | 3.00 |
| 500-G | 600 ohms | 40 ma | RESISTGOOD | 3.00 |
| 500-H | 1000 ohms | 30 ma | RESISTHYMN | 3.00 |
| 500-L | 2000 ohms | 22 ma | RESISTBELL | 3.00 |
| 500-M | 5000 ohms | 14 ma | RESISTPIPE | 3.00 |
| 500-J | 10,000 ohms | 10 ma | RESISTMILK | 3.00 |

RHEOSTATS AND VOLTAGE DIVIDERS

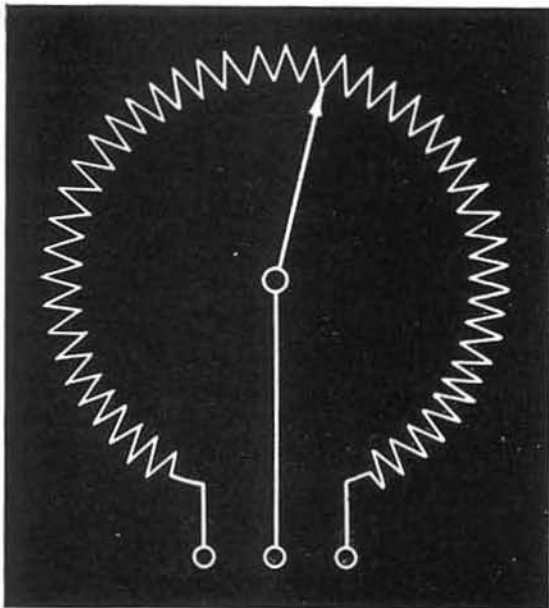

USES: Variable resistors and voltage dividers are useful in assembling experimental equipment where tube voltages and circuit elements are to be varied until the final design is obtained. In standard equipment, such as oscillators, bridges, test equipment, and industrial instruments, many manufacturers find General Radio rheostats extremely useful as filament- and plate-supply controls, output controls, bridge arms, and as parts of almost any instrument where variable resistances are needed. Ganged units can be used where simultaneous control is desired. Units with special resistance values or tolerances can be made to order. In addition to the ordinary linear models, tapered units of both the straight and logarithmic type can be made to satisfy particular requirements.

GENERAL DESCRIPTION: The resistance wire is wound on a strip of phenolic insulating material which is then bent around and fastened to the molded supporting form. Construction is so arranged that the shaft may extend through either or both ends of the rheostat.

All models are provided with mounting holes and with terminals which connect to both ends of the winding and to the contact arm. This arm is in continuous contact with the winding and there is no "off" position.

FEATURES: General Radio rheostats and voltage dividers are manufactured in five basic models under several different types of construction. The essential features of each type of design are outlined below. The shafts turn in accurately machined brass bushing inserts which are molded into the phenolic form.

Type 371-A. The resistance wire is wound on a linen phenolic strip, which is securely clamped to the supporting form. The contact arm is a specially formed single phosphor-bronze blade that provides smooth and firm contact with the edge of the winding.

Type 371-T. In this unit the resistance form is tapered linearly, so that the variation of resistance with angle of rotation follows a square law (increasing with clockwise rotation of the knob in a panel-mounted unit). In all other respects it is similar to the TYPE 371-A.

Type 214. This is similar to the TYPE 371-A in every respect except that the winding form is narrower.

Type 301. This type is a small, compact unit similar in construction to the TYPE 214.

Type 471. This is a high grade unit suitable for use in high-impedance circuits where low noise level is desired.

The high resistance windings are protected from mechanical damage or disturbance by an external protecting strip of linen phenolic.

An inside contact arm, bearing four separate wiping fingers, insures low noise level and extremely smooth operation.

Type 314. The design features of this unit are those of the TYPE 471; in physical dimensions it is similar to the TYPE 214.

SPECIFICATIONS

Accuracy: All types are wound to an accuracy of $\pm 5\%$ of the nominal values listed.

Maximum Current: The maximum current is the current which will produce the rated power dissipation when flowing through the entire winding. This current should not be exceeded in any portion of the winding.

Terminals: Screw terminals with 3-fingered tinned soldering lugs are provided on all models.

Accessories: All models are provided with the necessary screws and nuts for mounting, as well as a template for laying out the mounting holes. All units are supplied with knob and pointer.

RHEOSTATS

Mounting: All models can be arranged for either table or panel mounting.

Dimensions: Over-all size and mounting dimensions are shown on the sketches below.

Power Rating: In the table below are given the approximate power ratings of the various models. These ratings are for a temperature rise of from 50 to 60 degrees Centigrade for open shelf or panel mountings. When mounted in enclosed spaces slightly higher temperature rises or somewhat reduced ratings are to be expected.

| Type | Power Rating |
|-----------------------------|--------------|
| 214 | 10 watts |
| 301 | 4 watts |
| 301 (with protecting strip) | 3 watts |
| 314 | 8 watts |
| 371 | 15 watts |
| 471 | 12 watts |

MECHANICAL SPECIFICATIONS

| Type | Type of Shaft | Approximate Number of Total Turns | Useful Angle of Rotation | Net Weight in Ounces |
|------|------------------|-----------------------------------|--------------------------|----------------------|
| 214 | 1/4-in. Steel | 200† to 1250‡ | 303° | 6 |
| 301 | 1/4-in. Steel | 95† to 860‡ | 251° | 3 |
| 314 | 3/8-in. Phenolic | 675† to 1950‡ | 294° | 6 |
| 371 | 1/4-in. Steel | 615† to 1800‡ | 303° | 8 |
| 471 | 3/8-in. Phenolic | 900† to 1900‡ | 294° | 8 |

†For lowest resistance unit. ‡For highest resistance unit.
(intermediate values are proportional)

| Type | Maximum Resistance | Maximum Current | Code Word | Price |
|--------|--------------------|-----------------|-----------|--------|
| *314-A | 1000 Ω | 90 ma | DIVAN | \$5.00 |
| *314-A | 2000 Ω | 65 ma | ENEMY | 5.00 |
| *314-A | 5000 Ω | 40 ma | ENJOY | 5.00 |
| *314-A | 10,000 Ω | 28 ma | DIVER | 5.00 |
| *314-A | 20,000 Ω | 20 ma | ENROL | 5.00 |
| *314-A | 50,000 Ω | 13 ma | DONAX | 5.00 |
| *314-A | 100,000 Ω | 9 ma | DONGA | 5.00 |

TYPES 314, 471

| Type | A (Inches) | B (Inches) |
|-------|------------|------------|
| 314-A | 3 3/16 | 1 3/8 |
| 471-A | 3 3/16 | 2 5/8 |

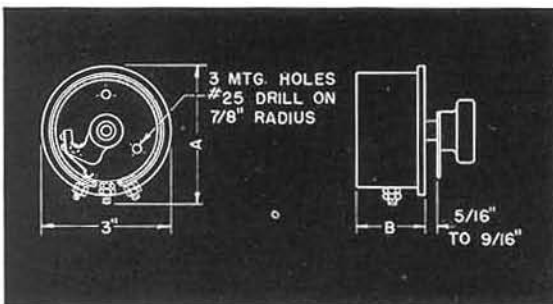

| Type | Maximum Resistance | Maximum Current | Code Word | Price |
|--------|--------------------|-----------------|-----------|--------|
| *471-A | 10,000 Ω | 35 ma | ERECT | \$7.00 |
| *471-A | 20,000 Ω | 25 ma | HUMAN | 7.00 |
| *471-A | 50,000 Ω | 15 ma | ERODE | 7.00 |
| *471-A | 100,000 Ω | 10 ma | ERUPT | 7.00 |
| *471-A | 200,000 Ω | 8 ma | ESKER | 7.00 |

*Supplied with linen-phenolic protecting strip.

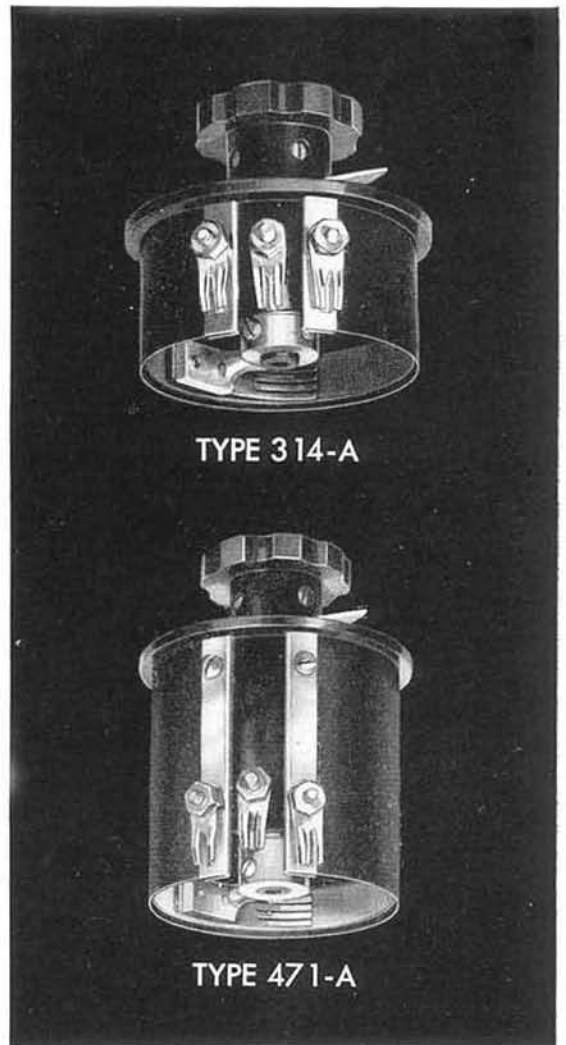

RHEOSTATS

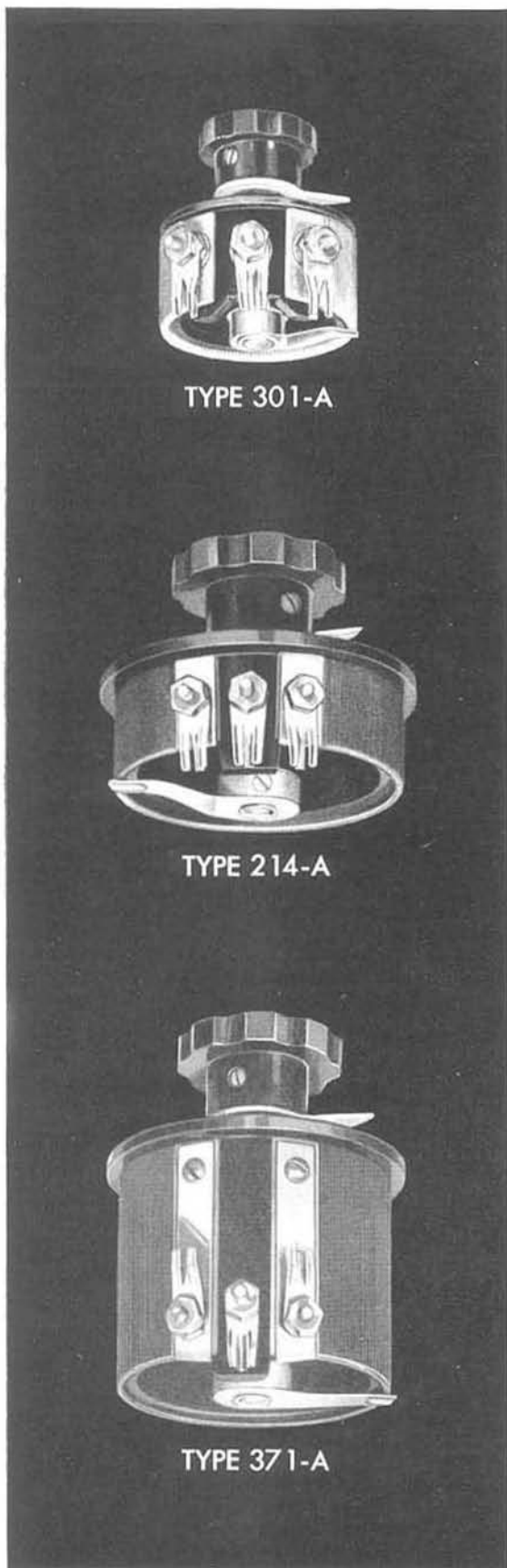

TYPE 301-A

TYPE 214-A

TYPE 371-A

TYPE 301

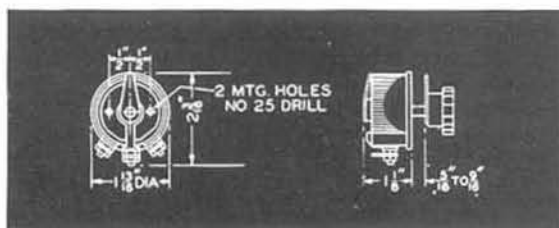

| Type | Maximum Resistance | Maximum Current | Code Word | Price |
|-------|--------------------|-----------------|-----------|--------|
| 301-A | 5 Ω | 0.9 a | PALSY | \$2.25 |
| 301-A | 10 Ω | 0.65a | HEMIT | 2.25 |
| 301-A | 20 Ω | 450 ma | RENEW | 2.25 |
| 301-A | 50 Ω | 280 ma | RIFLE | 2.25 |
| 301-A | 100 Ω | 200 ma | RIGID | 2.25 |
| 301-A | 200 Ω | 140 ma | REBUS | 2.25 |
| 301-A | 500 Ω | 90 ma | RIVAL | 2.25 |
| 301-A | 1000 Ω | 65 ma | RAVEL | 2.50 |
| 301-A | 2000 Ω | 45 ma | READY | 2.50 |
| 301-A | 5000 Ω | 28 ma | ROMAN | 2.75 |
| 301-A | 10,000 Ω | 17 ma | CURRY | 2.75 |
| 301-A | 20,000 Ω | 12 ma | CRUMB | 2.75 |

*Supplied with linen-phenolic protecting strip.

| Type | Maximum Resistance | Maximum Current | Code Word | Price |
|-------|--------------------|-----------------|-----------|--------|
| 214-A | 10 Ω | 1.0 a | RURAL | \$2.75 |
| 214-A | 20 Ω | 0.7 a | RAZOR | 2.75 |
| 214-A | 50 Ω | 450 ma | RAPID | 2.75 |
| 214-A | 100 Ω | 320 ma | RIVET | 2.75 |
| 214-A | 200 Ω | 220 ma | EMPTY | 2.75 |
| 214-A | 500 Ω | 140 ma | ROBIN | 2.75 |
| 214-A | 1000 Ω | 100 ma | ENACT | 2.75 |
| 214-A | 2000 Ω | 70 ma | SYRUP | 2.75 |
| 214-A | 5000 Ω | 45 ma | ROWEL | 2.75 |
| 214-A | 10,000 Ω | 32 ma | RUMOR | 2.75 |

TYPES 214, 371

| Type | A (Inches) | B (Inches) |
|-------|------------|------------|
| 214-A | 3 3/16 | 1 1/4 |
| 371-A | 3 3/16 | 2 1/2 |

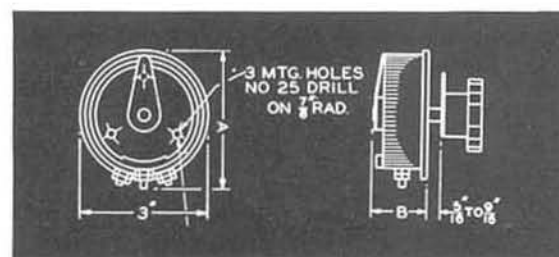

| Type | Maximum Resistance | Maximum Current | Code Word | Price |
|-------|--------------------|-----------------|-----------|--------|
| 371-A | 1000 Ω | 120 ma | REDAN | \$5.00 |
| 371-A | 2000 Ω | 90 ma | REFF | 5.00 |
| 371-A | 5000 Ω | 55 ma | ROTOR | 5.00 |
| 371-A | 10,000 Ω | 38 ma | HOWDY | 5.00 |
| 371-A | 20,000 Ω | 28 ma | RULER | 5.00 |
| 371-A | 50,000 Ω | 16 ma | SATYR | 5.00 |
| 371-A | 100,000 Ω | 11 ma | SEPOY | 5.00 |
| 371-T | 10,000 Ω | 28 ma | SULLY | 5.00 |





CAPACITORS and INDUCTORS

||-||-||-||-||-||

AIR AND MICA
STANDARDS

•
VARIABLE AIR
CAPACITORS

•
DECADE CAPACITORS
•
FIXED AND VARIABLE
INDUCTORS

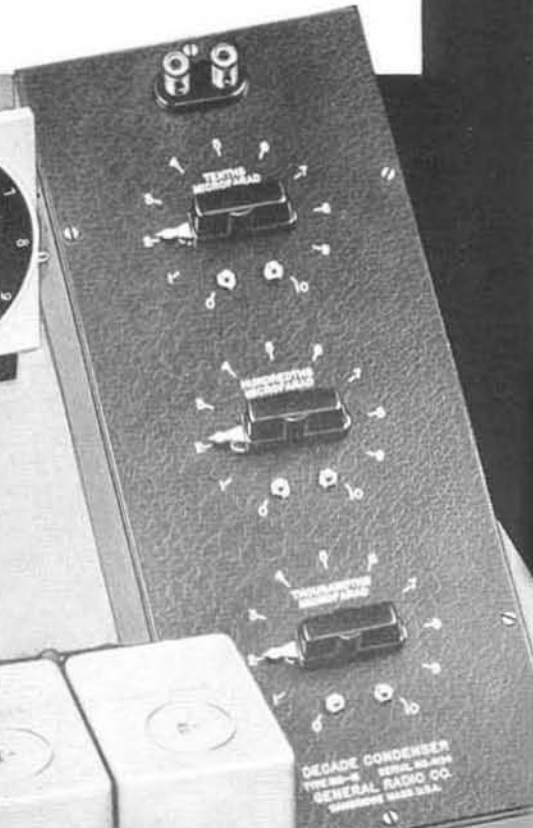

RESIDUAL IMPEDANCES IN CAPACITORS AND INDUCTORS

1. VARIABLE AIR CAPACITORS

As a continuously adjustable standard of impedance the variable air capacitor approaches very closely the ideal circuit element. At audio and low radio frequencies the residual components are usually negligible, and it is permissible to consider the capacitor as having a pure, constant capacitance. However, for use in precise measurements of impedance, especially at high radio frequencies, it is necessary to take account of the small residual parameters. Figure 1 is an equivalent circuit showing these residual impedances.

The parameters R , L , and G are all essentially constant as a function of dial setting for TYPE 722 Precision Condensers. The dielectric conductance G may be considered as the sum of two components, one, the d-c leakage conductance, which is constant with frequency and negligible at frequencies above about 5 cycles per second, and the other a conductance corresponding to polarization loss in the supports, which increases approximately as the first power of the frequency.

At low frequencies, the metallic resistance R is constant; at high frequencies (above 100 kc), where skin effect is essentially complete, it increases as the square root of the frequency. The inductance L remains very closely constant as a function of frequency, and causes the effective terminal capacitance C_e to depart from the static capacitance C according to the law

$$C_e = \frac{1}{1 - \omega^2 LC} \quad (1)$$

The metallic resistance R and the dielectric conductance G combine to cause a dissipative component of impedance, which can be expressed either as a series resistance or a parallel conductance:

$$R_e = R + \frac{G}{(\omega C)^2} \quad (2)$$

$$G_e = G + R(\omega C)^2 \quad (3)$$

The corresponding over-all dissipation factor is approximately

$$D = D_G + D_R = \frac{G}{\omega C} + R\omega C \quad (4)$$

A precision capacitor is used normally under such conditions that the dissipation factor components, D_G and D_R , and the inductive error are small. The expressions for the effective terminal impedance and admittance of the capacitor under these conditions are

$$Z_e = R_e - j \frac{1}{\omega C_e} \quad (5)$$

$$Y_e = G_e + j\omega C_e \quad (6)$$

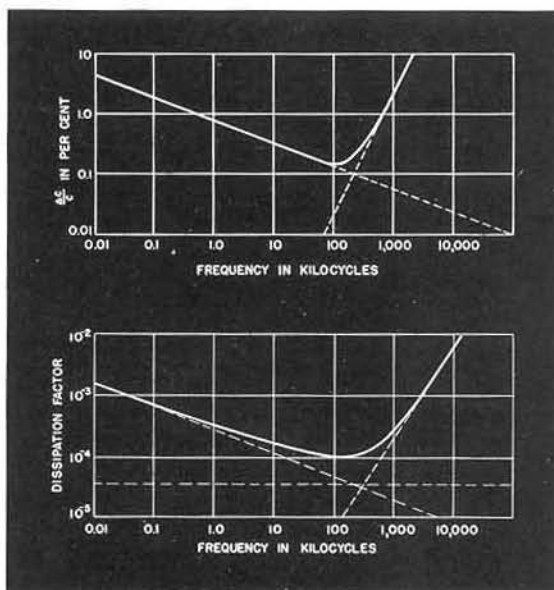
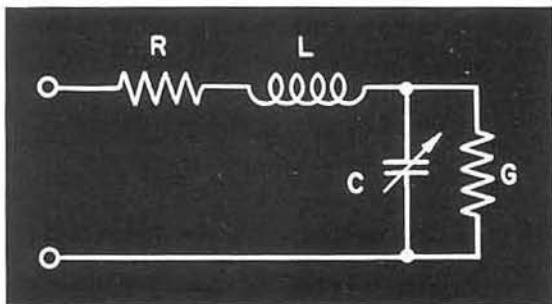

FIGURE 2. The variation, with frequency, of capacitance, *a* (top), and dissipation factor, *b* (bottom) of a fixed solid-dielectric capacitor.

At low frequencies, the effects of the residual parameters R and L are negligible and the capacitor acts like a pure capacitance C in parallel with a conductance G or in series with a resistance

$$R_G = \frac{G}{(\omega C)^2} \quad (7)$$

Under this condition

$$D_G C = R_G \omega C^2 = \frac{G}{\omega} \quad (8)$$

is a constant, where D_G is the dissipation factor corresponding to the dielectric loss. The numerical value of this constant is a convenient figure of merit to define the magnitude of the losses at low frequencies.

At high frequencies the other residual parameters become important. The losses in the metal parts of the capacitor increase with frequency until they are first comparable to and finally in excess of, the losses in the solid dielectric. At high frequencies it is, therefore, necessary to consider both components of loss.

2. FIXED SOLID-DIELECTRIC CAPACITORS

The same residual impedances shown in Figure 1 for air capacitors are present in solid-dielectric capacitors, but, because of a different mechanical structure and because the capacitance is concentrated in the solid dielectric, their relative magnitudes are different.

The effects of interfacial polarization in the dielectric are shown by the low-frequency portions of Figure 2, *a* and *b*. On these log-log plots the slope of

FIGURE 1. The equivalent circuit of a variable air capacitor C . R represents the series metallic resistance, L the inductance, and G the dielectric conductance.

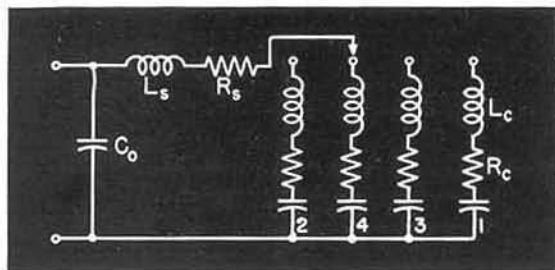

FIGURE 3. Equivalent circuit of a TYPE 380 Decade-Capacitor Unit showing the additional residual impedances produced by the switches and wiring.

the lines is characteristic of the dielectric material. At very low frequencies, the d-c leakage conductance adds a component to the dissipation factor, but does not affect capacitance. It is normally negligible, even at 10 cycles per second.

At high frequencies, the series residuals cause dissipation factor to increase as the 3/2 power of frequency, while the fractional change in capacitance increases as the square of frequency (See Equation 1).

Fractional change in capacitance and dissipation factor each have a minimum value, which occurs at a frequency that varies inversely with capacitance and that can be as low as 1 ke and as high as 10 Mc. For small capacitances, where the effect of series

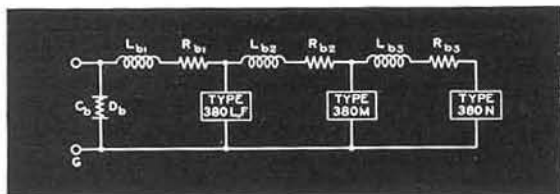

FIGURE 4. Equivalent circuit of a TYPE 219 Decade Condenser.

resistance appears only at very high frequencies, a residual polarization, having a dissipation factor constant with frequency, sets a minimum value for dissipation factor. It is also in this frequency range around 1 Mc that the effect of dipole polarization occurs. Dielectrics ordinarily used for capacitors rarely show the effects of this polarization.

When capacitors are assembled into decades, as in the TYPE 380 Decade-Capacitor Units, the series residuals are increased by the switch as shown in Figure 3. There is also a terminal capacitance with dielectric loss. The assembling of several decades into a TYPE 219 Decade Condenser adds more series residuals and more terminal capacitance, as shown in Figure 4. The solution of these more complicated networks is discussed in the *General Radio Experimenter*, Vol. XVII, No. 5, October, 1942.

Because there is no frequency at which capacitance has reached a constant value, each General Radio capacitor is adjusted to have its nominal value of capacitance at 1 ke.

3. AIR-CORED INDUCTORS

The residual impedances in air-cored inductors are

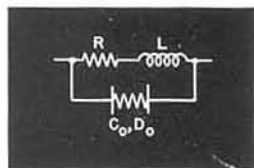

FIGURE 5. Equivalent circuit of an air-cored inductor L .

a series resistance R of the copper winding and a distributed capacitance represented in Figure 5 by a lumped capacitance C_0 having a dissipation factor D_0 . The inductor has a natural frequency f_0 determined by the expression

$$f_0 = \frac{1}{2\pi\sqrt{LC_0}} \quad (9)$$

This causes the series inductance to increase as the natural frequency is approached according to the law

$$L_c = \frac{L_s}{1 - f_0^2} \quad (10)$$

The parallel inductance is unaffected, except for the slight decrease in the inductance brought about by skin effect. This effect is only noticeable in single-layer coils and is minimized by the use of insulated stranded wire (Litzendraht).

The effects of the various loss components are most easily represented by the plot of dissipation factor against frequency, Figure 6. In this plot, D_c is the component of dissipation factor caused by the d-c resistance, D_e is caused by eddy currents in the wire, and D_f is the dielectric loss in the distributed capacitance. The total dissipation factor D is the sum of these components and has a minimum value at a frequency well below f_0 the natural frequency.

4. IRON-CORED INDUCTORS

Since fewer turns are necessary for a given inductance because of the high permeability of the core, D_c and D_e are less for an iron-cored coil than for one with an air core. The distributed capacitance C_0 and hence D_f are greater owing to the conductivity of the iron core. Two additional loss components are present however, that are caused by hysteresis and eddy currents in the core. The eddy current component D_i increases with frequency, while the hysteresis component D_h is constant with frequency. The component D_i is independent of flux density and is lower for thinner laminations and for dust cores. D_h depends upon flux density and is negligible only at flux densities at least as low as those corresponding to initial permeability. See *General Radio Experimenter*, Vol. XVI, No. 10, March, 1942.

Each General Radio inductor, whether air- or iron-cored is adjusted to have its nominal value at a sufficiently low frequency so that it is the same as its d-c value.

It is perhaps more usual to express the losses in terms of the storage factor Q which is the reciprocal of dissipation factor D . Dissipation factor D has been used here because, where there are several kinds of losses, dissipation factors add directly.

FIGURE 6. The variation with frequency of the dissipation factor of an air-cored inductor showing the relative contributions of the several loss components.

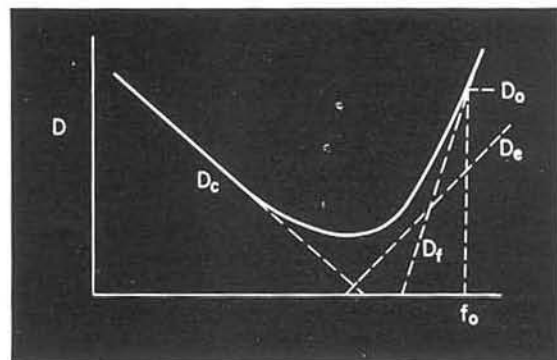

TYPE 722 PRECISION CONDENSER

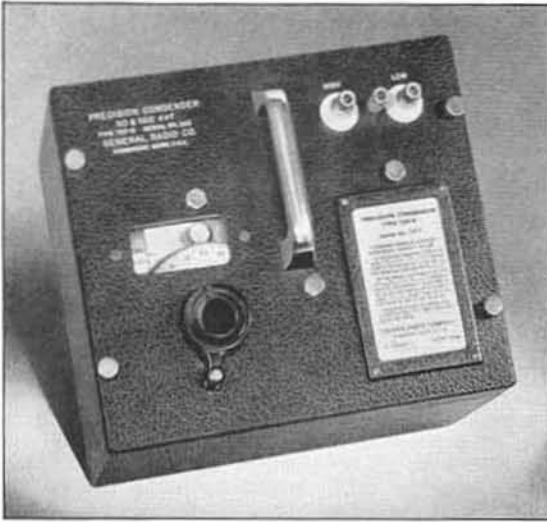

Panel view of the TYPE 722-D Precision Condenser.

USES: The TYPE 722 Precision Condenser is a variable air capacitor intended for use as a standard of capacitance.

It is widely used in a-c bridges both as a built-in standard and as an external standard for substitution measurements. It is also used as a tuning capacitor in oscillators, frequency meters, and other instruments where accuracy and stability are important.

DESCRIPTION: The whole capacitor assembly is mounted in a cast frame, which is used to give the unit rigidity. This frame, the stator rods and spacers, and the rotor shaft are made of alloys of aluminum which combine the mechanical strength of brass with the weight and temperature coefficient of aluminum. The plates are of aluminum, so that all parts have the same temperature coefficient of linear expansion.

A worm drive is used in this capacitor to obtain the desired precision of setting. In order to avoid the slight eccentricity which is almost inevitable when a worm gear is mounted on a shaft, the worm in the TYPE 722 Precision Condenser is cut directly on the shaft. The dial end of this worm shaft runs in ball bearings, while the other end is supported by an adjustable spring mounting. Ball bearings are used at both ends of the rotor shaft. Electrical connection to the rotor is made, not through the bearing, but by means of a phosphor-bronze brush running on a brass drum. This method assures a positive electrical contact.

A preliminary assembly of the frame, shaft, and gears is driven by a motor to grind in the gears before final assembly.

FEATURES: ▶ A high degree of stability, under constant laboratory use, has been obtained by carefully selecting both materials and the mechanical arrangement used in the TYPE 722 Precision Condenser.

▶ The precision of setting of all models is one part in 25,000 of full scale, more than adequate for most measurement uses.

▶ Direct-reading accuracy is within $\pm 0.1\%$ of full scale, and correction data are supplied so that accuracies of $\pm 0.1\%$ can be obtained at lower scale settings. A more precise calibration with a worm correction can be supplied, giving corrections which permit an internal consistency of $0.1 \mu\text{mf}$. The usable accuracy at the terminals may still be limited to approximately $1 \mu\text{mf}$ by the lack of a standard technique for connecting the capacitor into a measuring circuit. (See *General Radio Experimenter*, Vol. XXI, No. 12, May, 1947, for a complete discussion of connection errors.)

▶ Backlash has been reduced to less than one-half a worm division by careful arrangement of the bearings and drive mechanism.

▶ The temperature coefficient of capacitance has been kept to about 20 parts per million per degree Centigrade by using metal parts which all have the same temperature coefficient of linear expansion.

▶ Low dielectric losses are assured by using a low-loss ceramic for the solid dielectric and by keeping the capacitance associated with it very small. When it is desired to reduce the dielectric losses still further, quartz insulation coated with a silicone resin can be used instead of the ceramic. The coating prevents the formation of a continuous water film at 100% relative humidity or even under dew-point condensation.

Interior view of the TYPE 722-D Precision Condenser.

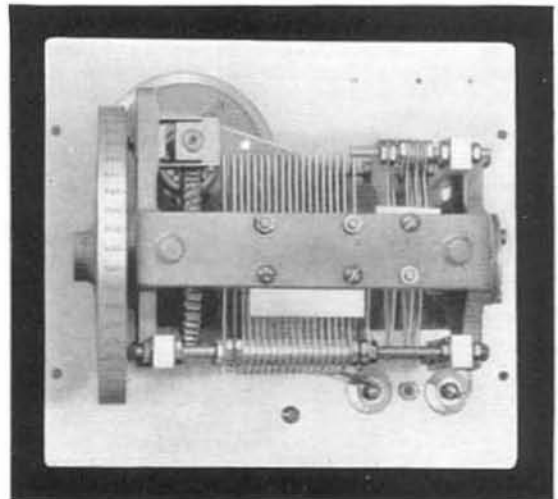

SPECIFICATIONS

Capacitance Range: Two stock models are available: TYPE 722-D, direct reading in capacitance over two ranges, 25 to 110 μf , and 100 to 1100 μf ; TYPE 722-M, intended for bridge-substitution measurements and direct reading in capacitance removed from the capacitor over a range of 1000 μf .

Rotor Plate Shape: Semicircular for all models, to give a linear capacitance characteristic.

Standard Calibration Accuracy: TYPE 722-D: The capacitance of the HIGH section, 100 to 1100 μf , is indicated directly in micromicrofarads by the dial and drum readings within $\pm 1 \mu\text{f}$. The capacitance of the LOW section, 25 to 110 μf , is indicated directly in micromicrofarads by one-tenth of the dial and drum readings within $\pm 0.2 \mu\text{f}$.

TYPE 722-M: The capacitance at a reading of zero for the dial and drum is indicated on a small card mounted on the panel. This capacitance, about 1150 μf in magnitude, is given to 0.1 μf and is accurate within $\pm 1 \mu\text{f}$. The capacitor is adjusted to indicate directly in micromicrofarads the capacitance removed from the circuit to an accuracy of $\pm 1 \mu\text{f}$.

In addition, a correction chart is supplied giving corrections to 0.1 μf , at multiples of 100 μf . By using these data the direct-reading accuracy which can be obtained for the HIGH section of the TYPE 722-D is $\pm 0.1\%$ or $\pm 0.4 \mu\text{f}$, whichever is the greater, and capacitance differences can be measured to $\pm 0.1\%$ or $\pm 0.5 \mu\text{f}$, whichever is the greater. For the LOW section an accuracy of $\pm 0.1 \mu\text{f}$ can be obtained for both direct capacitance and capacitance differences. Capacitance differences on the TYPE 722-M can also be obtained to $\pm 0.1\%$ or $\pm 0.5 \mu\text{f}$, whichever is the greater, by using the correction data.

Worm Correction Calibration: Worm corrections can be supplied for both models at an extra charge indicated in the price list. Mounted charts are supplied, which give the corrections to at least one more figure than the guaranteed accuracies, which are stated below.

TYPE 722-D: When the worm correction is used, the capacitance of either section can be determined within $\pm 0.1 \mu\text{f}$ or $\pm 0.1\%$, whichever is the greater, and capacitance differences can be measured to an accuracy of $\pm 0.2 \mu\text{f}$ or $\pm 0.1\%$, whichever is the greater, with the HIGH section; and $\pm 0.04 \mu\text{f}$ or $\pm 0.1\%$, whichever is the greater, with the LOW section.

TYPE 722-M: Capacitance differences, in capacitance removed, can be measured within $\pm 0.2 \mu\text{f}$ or $\pm 0.1\%$, whichever is the greater.

Maximum Voltage: All models, 1000 volts, peak.

Dielectric Supports: Two bars of steatite support the stator assembly, and conical bushings insulate the terminals from the panel. Quartz insulation can be supplied on special order. (See price list.)

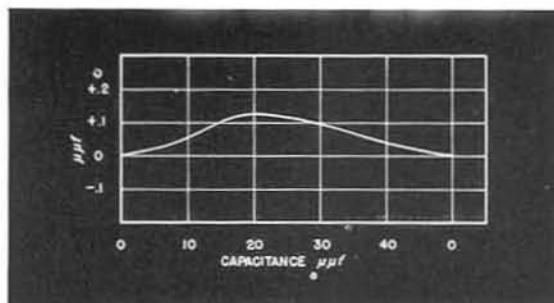

Plot of a typical worm correction for a TYPE 722 Precision Condenser.

Dielectric Losses: The figure of merit, DC (dissipation factor times capacitance), when measured at 1 kc is approximately 0.04 μf for steatite insulation and 0.003 μf for quartz.

Residual Parameters: The series inductance and the series metallic resistance are given in the following table:

| Type | L | R at 1 Mc |
|--------------|---------------------|---------------|
| 722-D | | |
| high section | 0.065 μh | 0.02 Ω |
| low section | 0.11 μh | 0.03 Ω |
| 722-M | 0.060 μh | 0.02 Ω |

The series resistance varies as the square root of the frequency for frequencies above 100 kc.

Temperature Coefficient: The temperature coefficient of capacitance is approximately $+0.002\%$ per degree Centigrade, for small temperature changes.

Drive: A worm-and-gear drive is used. To reduce irregularities and backlash the worm is cut integral with the shaft. The backlash is less than one-half worm division (there are 250 divisions per worm turn for the TYPE 722-D and the TYPE 722-M). If the desired setting is always approached in the direction of increasing scale reading, no calibration error from this cause will result.

Terminals: Jack-top binding posts are provided. Standard $\frac{3}{4}$ -inch spacing is used. The rotor terminal is connected to the panel and shield.

Mounting: The capacitor is mounted on an aluminum panel finished in black crackle lacquer and enclosed in a shielded walnut cabinet. A wooden storage case with lock and carrying handle is included.

Dimensions: Panel, 8 x 9 $\frac{1}{8}$ inches; depth, 8 $\frac{1}{8}$ inches.

Weight: 10 $\frac{1}{2}$ pounds; 19 $\frac{3}{4}$ pounds with carrying case.

| Type | Capacitance Range | Code Word | Price |
|--|--|-----------|----------|
| 722-D | 25 to 110 μf and 100 to 1100 μf , direct reading | CRUEL | \$175.00 |
| 722-M | 0 to 1000 μf , direct reading in capacitance removed from circuit | COMIC | 140.00 |
| Worm-Correction Calibration for Type 722-M | | WORMY | 50.00 |
| Worm-Correction Calibration for Type 722-D | | WORMY | 70.00 |

When ordering, use compound code word, CRUELWORMY, etc.

QUARTZ INSULATION

Any TYPE 722 Precision Condenser can be obtained with quartz insulation.

| | Code Word | Additional Price |
|--|-----------|------------------|
| Quartz Insulators for Type 722-M | QUATZ | \$65.00 |
| Quartz Insulators for Types 722-D or 722-N | QUATZ | 85.00 |

When ordering, use compound code word, CRUELQUATZ, etc.



CAPACITORS

TYPE 722-N PRECISION CONDENSER FOR USE AT RADIO FREQUENCIES

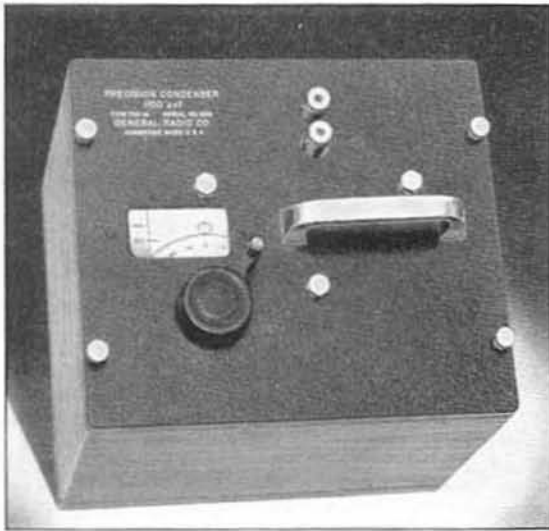

USES: This capacitor has been designed particularly for use as a standard at radio fre-

quencies in series- or parallel-resonance methods of impedance measurement. It is also useful as a variable capacitor in radio-frequency bridges.

DESCRIPTION: The frame, bearing, and drive mechanism of this capacitor are identical with those used on the other TYPE 722 Precision Condensers. The rotor and stator leads, however, are not brought out in the conventional manner. In the TYPE 722-N Precision Condenser connection is made at the center of both plate stacks.

The rotor connection is made by spring-temper silver alloy brushes bearing on a silver-overlay brass disc.

FEATURES: The important features of this capacitor are its low metallic resistance and low inductance. Both of these quantities are about one-third the magnitude of those in the TYPE 722-D. The accuracy of calibration is as good and the dielectric losses nearly as low as in the other TYPE 722 Condensers.

SPECIFICATIONS

Capacitance Range: 100 to 1100 μf , direct reading.

Rotor Plate Shape: Semicircular to give a linear capacitance characteristic.

Standard Calibration Accuracy: The capacitance, measured at 1 kc, is indicated directly in micromicrofarads by the dial and drum readings to $\pm 1 \mu\text{f}$.

A correction chart is supplied giving corrections to 0.1 μf at multiples of 100 μf . By using these data the direct-reading accuracy is $\pm 0.1\%$ or $\pm 0.4 \mu\text{f}$, whichever is the greater, and the accuracy for capacitance differences is $\pm 0.1\%$ or $\pm 0.5 \mu\text{f}$, whichever is the greater.

Worm Correction Calibration: A worm correction can be supplied on special order. (See price list.) A mounted chart is supplied giving the corrections to at least one more figure than the guaranteed accuracy stated below.

When the worm correction is used, the capacitance can be determined within $\pm 0.1 \mu\text{f}$ or $\pm 0.1\%$, whichever is the greater, and capacitance differences can be measured to an accuracy of $\pm 0.2 \mu\text{f}$ or $\pm 0.1\%$, whichever is the greater.

Dielectric Supports: Two bars of steatite support the stator assembly, and a third bar insulates the high terminal from the panel. Quartz insulation can be supplied on a special order. See price list on preceding page.

Dielectric Losses: The figure of merit, DC (dissipation factor times capacitance), when measured at 1 kc, is approximately 0.05 μf . (See discussion on page 42.)

Other Residual Parameters: The series metallic resistance is about 0.008 ohm at 1 megacycle and increases directly as the square root of the frequency. The dielectric and metallic losses are approximately equal at a setting of 1000 μf and a frequency of 1 Mc.

The series inductance is approximately 0.024 μh . The increase in capacitance caused by this inductance reaches 10% at a setting of 1000 μf and a frequency of 10 Mc.

At smaller capacitance settings the effects of residual

parameters are less. The equal division of losses occurs at 20 Mc for a setting of 100 μf and the 10% capacitance rise occurs at 30 Mc for the same setting.

Maximum Voltage: 1000 volts, peak.

Temperature Coefficient: Approximately $\pm 0.002\%$ per degree Centigrade, for small temperature changes.

Mounting: The capacitor is mounted on an aluminum panel finished in black crackle lacquer and enclosed in a shielded walnut cabinet. A wooden storage case with lock and carrying handle is included.

Dimensions: Panel, 8 x 9 $\frac{1}{4}$ inches; depth, 8 $\frac{1}{4}$ inches.
Net Weight: 11 $\frac{1}{4}$ pounds; 20 $\frac{1}{2}$ pounds with carrying case.

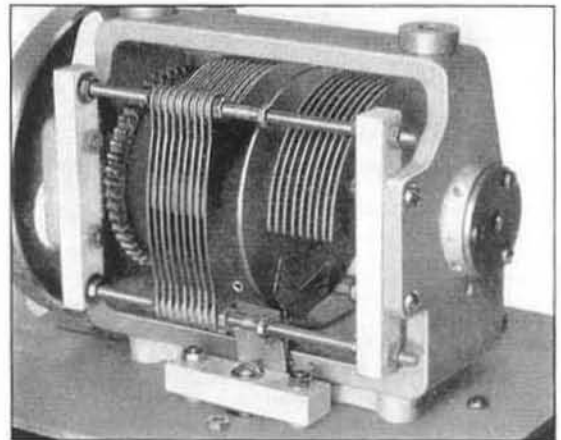

Interior photograph of a Type 722-N Precision Condenser with half the stator removed, showing the leads and the method of connection to the rotor.

| Type | Code Word | Price |
|-----------------------------|-----------|----------|
| 722-N | BOXER | \$160.00 |
| Worm-Correction Calibration | WORMY | 50.00 |

When ordering, use compound code word, BOXERWORMY.

TYPE 848 VARIABLE AIR CAPACITOR

USES: The TYPE 848 Variable Air Capacitor is designed for use in radio-frequency equipment. The linear models, for instance, can be used as impedance-bridge elements, and the logarithmic model, TYPE 848-L, as a tuning element for radio-frequency oscillators. The mounted model, TYPE 848-BM, is direct-reading in capacitance, and finds many uses where the high accuracy of the TYPE 722 Precision Condenser is not needed.

DESCRIPTION: Both the rotor and the stator are insulated from the frame, and contact to the rotor is made by a slip ring and a 4-fingered brush. The rotor and stator stacks are made up of brass plates soldered into single units, which are then nickel plated. The rotor is mounted in spherical oil-impregnated bearings, which are mounted on metal endplates, rigidly supported by four metal corner rods. Stator supports are small ceramic cones.

FEATURES: ▶ Rigid construction and self-aligning spherical bearings assure mechanical stability.

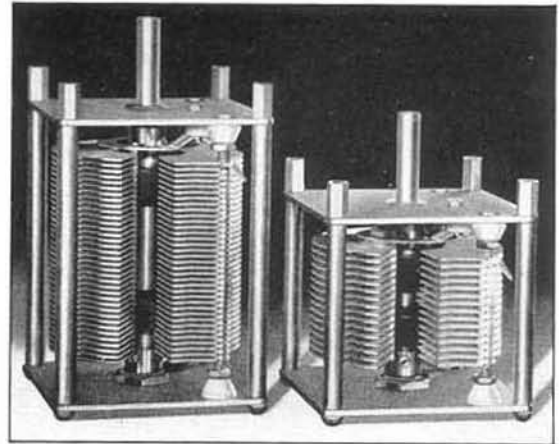

- ▶ Soldered plate construction keeps ohmic resistance low.
- ▶ Insulated rotor and stator make the capacitor usable as either a 3-terminal or a 2-terminal element.
- ▶ Capacitance from stator to frame and from rotor to frame has been kept low.

SPECIFICATIONS

Capacitance Range: Four unmounted models and one mounted model are listed below.

Calibration: The TYPE 848-BM has a dial direct-reading in capacitance.

Plate Shape: Semicircular straight-line capacitance plates on all models except the TYPE 848-L, which is designed to give a logarithmic frequency variation in a tuned-circuit r-f oscillator over a frequency range of $\sqrt{10}:1$.

Dielectric Losses: The figure of merit DC (dissipation factor times capacitance) is approximately 0.02 μmf for all types.

Supports: All models have metal endplates with small ceramic cones supporting the stator. The rotor is insulated from the shaft by two polystyrene collars.

Maximum Voltage: 1100 volts peak for TYPE 848-A, and 700 volts peak for all others.

Shaft: $\frac{3}{8}$ -inch solid steel shaft on all models.

Drive: No knobs or drives are supplied except on the TYPE 848-BM which has a direct-reading dial.

Terminals: Soldering lugs on unmounted models; standard jack-top binding posts on mounted model.

Mounting: TYPE 848-BM is mounted on an aluminum panel in a shielded cabinet. All other models are unmounted.

Dimensions: TYPE 848-BM mounted model, $5\frac{1}{2} \times 5\frac{1}{2}$ inches, x (height) 7 inches, over-all. Unmounted models, see accompanying sketch.

Net Weight: TYPES 848-A, -B, and -L, $2\frac{3}{8}$ pounds; TYPE 848-C, $3\frac{1}{2}$ pounds; TYPE 848-BM, $8\frac{1}{2}$ pounds.

| Type | Nominal Capacitance—Rotor Grounded | | Nominal Maximum Capacitance to Frame | | Code Word | Price |
|---------|------------------------------------|-------------------|--------------------------------------|-------------------|-----------|---------|
| | Maximum | Minimum | Rotor | Stator | | |
| 848-A | 550 μmf | 20 μmf | 15 μmf | 12 μmf | CAMEL | \$17.00 |
| 848-B | 1100 μmf | 20 μmf | 15 μmf | 12 μmf | CALIF | 19.00 |
| *848-BM | 1100 μmf | 22 μmf | | | CRISP | 47.00 |
| 848-C | 2100 μmf | 29 μmf | 18 μmf | 16 μmf | CREST | 24.00 |
| 848-L | 820 μmf | 21 μmf | 13 μmf | 12 μmf | COLIC | 23.00 |

*Cabinet-mounted model with dial direct-reading in capacitance.

Dimensional sketches for (left) TYPE 847, and (right) TYPE 848 Variable Air Capacitors.

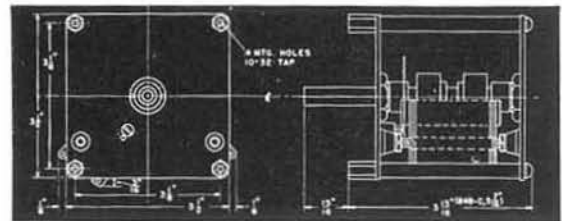
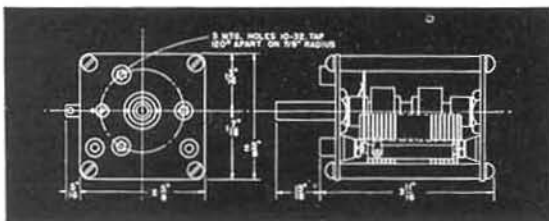

CAPACITORS

TYPE 847 VARIABLE AIR CAPACITOR

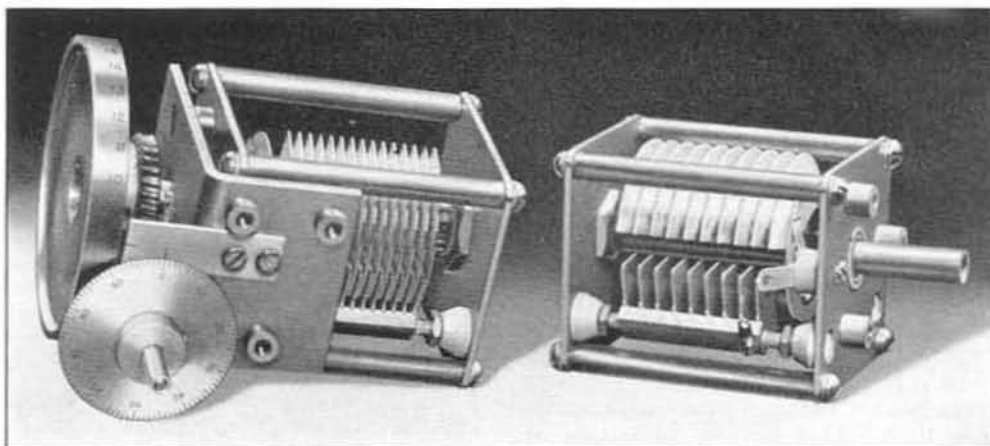

TYPE 847-C with TYPE 847-P1 Drive, and TYPE 847-A.

USES: The TYPE 847 Variable Air Capacitor is a smaller unit than the TYPE 848, but is similar in construction. It has the same general applications as the larger capacitor, but is available only in lower capacitance models.

DESCRIPTION: General design and construction are similar to those of the TYPE 848.

FEATURES: ▶ Rotor and stator are both insulated from the frame in all models.

▶ Soldered plate construction keeps resistance low.

▶ Spherical oil-impregnated bearings are self-aligning, and assure mechanical stability.

▶ Worm-drive dial and drum assembly is available for all models.

SPECIFICATIONS

Capacitance Range: Three models are listed below.

Plate Shape: Semicircular straight-line capacitance on all models.

Dielectric Losses: The figure of merit DC (dissipation factor times capacitance) is approximately 0.02 μf for all types.

Supports: All models have metal endplates with small ceramic cones supporting the stator. All rotors are insulated from the shafts by polystyrene collars. Maximum nominal capacitance of rotor to frame is 13 μf , and stator to frame 11 μf .

Maximum Voltage: 1500, 1400, and 1100 volts peak, for the TYPES 847-A, -B, and -C, respectively.

Shaft: $\frac{3}{8}$ -inch solid steel shaft on all models.

Drive: No knobs or drives are supplied, but the TYPE 847-P1 Worm Drive Assembly is available separately (see below).

Terminals: Tinned copper soldering lugs are provided.

Mounting: See sketch on preceding page. Three mounting screws are furnished.

Dimensions: See sketch on preceding page.

Net Weight: All models, 1 $\frac{3}{8}$ pounds. TYPE 847-P1, 1 pound.

| Type | Nominal Capacitance—Rotor Grounded | | Code Word | Price |
|--------|------------------------------------|------------------|-----------|---------|
| | Maximum | Minimum | | |
| 847-A | 75 μf | 15 μf | CAPER | \$13.00 |
| 847-B | 110 μf | 16 μf | CAPON | 14.00 |
| 847-C | 220 μf | 16 μf | CARAT | 16.00 |
| 847-P1 | Worm Drive Assembly, 30:1 | | DRYAD | 15.00 |

TYPE 846 VARIABLE AIR CAPACITOR

USES: The TYPE 846 Variable Air Capacitor is designed primarily for use as a trimmer capacitance in oscillators, bridges, and other audio-frequency and radio-frequency equipment. At high frequencies, because of its low residual impedances, it is usable as a tuning capacitance in receivers and oscillators.

DESCRIPTION: Soldered brass plates, nickel plated, are used in this capacitor. The stator is mounted on a single low-loss thermoplastic end plate, which serves as an insulating mounting plate and as a bearing. Two shaft styles are listed, one for use with a knob, and one for screwdriver adjustment.



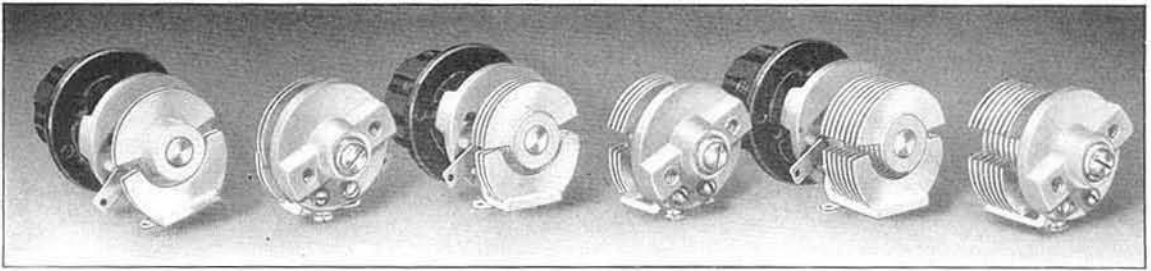

FEATURES: ▶ The TYPE 846 Variable Air Capacitors are small and easy to mount.
▶ Dielectric losses are extremely low.

▶ Ohmic resistance is kept low through the use of soldered plates.
▶ Long sleeve bearing aids stability.

SPECIFICATIONS

Capacitance Range: Three ranges are available as listed below.
Plate Shape: All models have semicircular rotor plates giving approximately linear capacitance variation with angular setting.
Dielectric Losses: The figure of merit DC (dissipation factor times capacitance) is less than 0.004 μf for all types.
Support: A single low-loss thermoplastic endplate supports the entire assembly.
Maximum Voltage: 500 volts peak.
Drive: All "K" models have extended shafts for knob drive and are supplied with a TYPE KNSP-6 knob. All "T" models have flush shafts with a slot for screwdriver drive.

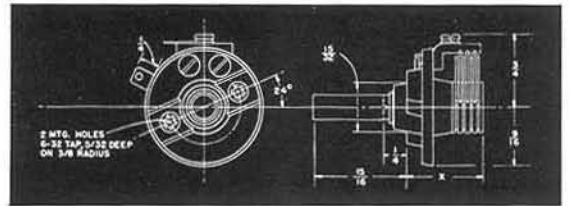

Terminals: Tinned copper soldering lugs are provided.
Mounting: See accompanying sketch.
Dimensions: See accompanying sketch. Depth (dimension X) is given in table below.
Net Weight: "T" models about 1 1/2 ounces; "K" models about 2 1/2 ounces.

| Type | Capacitance | | Drive | Depth (X) | Code Word | Price |
|--------|------------------|-------------------|-------------|-----------|-----------|--------|
| | Maximum | Minimum | | | | |
| 846-AK | 11 μf | 2 μf | Knob | 7/8" | CABAL | \$2.35 |
| 846-AT | 11 μf | 2 μf | Screwdriver | 7/8" | CABIN | 2.00 |
| 846-BK | 20 μf | 2.5 μf | Knob | 7/8" | CABOB | 2.50 |
| 846-BT | 20 μf | 2.5 μf | Screwdriver | 7/8" | CADDY | 2.15 |
| 846-CK | 45 μf | 3.5 μf | Knob | 1 1/8" | CADET | 2.75 |
| 846-CT | 45 μf | 3.5 μf | Screwdriver | 1 1/8" | CANTO | 2.40 |

TYPE 509 STANDARD CONDENSER

USES: These capacitors are fixed standards for laboratory use. When they are used in conjunction with a TYPE 722-D or a TYPE 722-M Precision Condenser in a parallel substitution method of measurement, precise measurements of capacitance up to several microfarads can be made. For capacitor manufacturers who maintain a capacitance standardization laboratory, a set of TYPE 509 Standard Condensers, used with a TYPE 716-C Capacitance Bridge, is recommended.

DESCRIPTION: Each TYPE 509 Standard Condenser consists of two TYPE 505 Capacitor units which have been put through an additional ageing process. The final accuracy and stability are thus increased markedly. The units are mounted in cast aluminum cases and are furnished with jack-top binding posts.

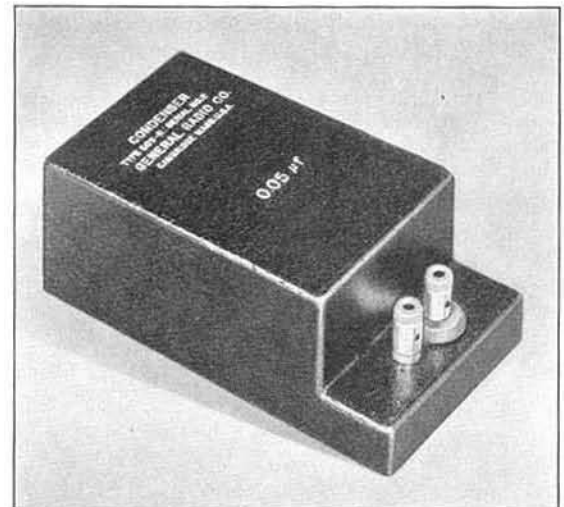

CAPACITORS

- FEATURES:** ▶ Stability within $\pm 0.1\%$ is obtained by carefully controlled ageing.
 ▶ An accurate calibration, within $\pm 0.1\%$ is furnished with each unit.
 ▶ Plug-in terminals are arranged for convenience in using the capacitors. Several

units can be stacked one upon the other without the use of leads. There is no cumulative error when the capacitors are so stacked, so that these units can be used in parallel in much the same way that precision gauges are added in mechanical measurements.

SPECIFICATIONS

Capacitance: Ten sizes are listed below.

Accuracy of Adjustment: Each capacitor is carefully adjusted within $\pm 0.25\%$ of the nominal capacitance value engraved on the case.

Accuracy of Calibration: After each capacitor has been aged, adjusted, and mounted, its capacitance is measured as carefully as possible, and the value of capacitance at 1 ke, accurate within $\pm 0.1\%$, is entered on a certificate of calibration which is packed with each unit.

Stability: Over reasonable periods of time (at least one year) each capacitor will maintain its calibrated value within $\pm 0.1\%$.

Temperature Coefficient: Less than $+0.01\%$ per degree Centigrade between 10° and 50° Centigrade.

Dissipation Factor: The dissipation factor of all units, when measured at 1 ke and 25° Centigrade, is less than 0.0005.

Frequency Characteristics: The variation of capacitance and dissipation factor with frequency is shown in the plots below. The rise in capacitance at low frequencies is caused by interfacial polarization in the dielectric, that at high frequencies by series inductance. (See table below.) The dissipation factor rises at low frequencies because of losses in the dielectric, and at high frequencies because of series metallic resistance.

This resistance at 1 Me is given in the table below and varies as the square root of the frequency for frequencies above 100 ke.

Leakage Resistance: The leakage resistance, when measured at 500 volts, is greater than 100,000 megohms except for the Types 509-U, 509-X, and 509-Y. In these units the resistance is greater than 50,000, 20,000, and 10,000 megohms, respectively.

Maximum Voltage and Frequency: The maximum peak voltage is 500 volts, at frequencies below the limiting frequencies tabulated below. At higher frequencies the allowable voltage decreases and is inversely proportional to the square root of the frequency. These limits correspond to a temperature rise of 40° Centigrade for a power dissipation of 3 watts for the small case and 5 watts for the large.

Mounting: Cast aluminum cases are used, small size for Types 509-F, -G, -K, -L, and -M, and large size for all others.

Terminals: Two jack-top binding posts spaced $\frac{3}{4}$ of an inch apart are mounted on the case. One terminal is grounded, and the other one is insulated by means of a low-loss phenolic bushing.

Dimensions: Small case, (length) $4\frac{1}{2}$ inches x (width) $2\frac{1}{2}$ inches x (height) $1\frac{3}{8}$ inches, over-all. Large case, (length) 6 inches x (width) $3\frac{3}{8}$ inches x (height) $2\frac{3}{8}$ inches, over-all.

Net Weight: Types 509-F, -G, $1\frac{1}{4}$ pounds; Types 509-K, -L, -M, $1\frac{3}{8}$ pounds; Types 509-R, -T, $2\frac{3}{8}$ pounds; Type 509-U, $2\frac{3}{4}$ pounds; Type 509-X, $3\frac{1}{4}$ pounds; Type 509-Y, $3\frac{3}{8}$ pounds.

| Type | Capacitance | Peak Volts | Frequency | L | R at 1 Mc | Case | Code Word | Price |
|-------|---------------|------------|-----------|---------------|----------------|-------|------------|---------|
| 509-F | 0.001 μ f | 500 | 2500 ke | 0.065 μ h | 0.040 Ω | Small | GOODCONBOY | \$22.00 |
| 509-G | 0.002 μ f | 500 | 1250 ke | 0.065 μ h | 0.040 Ω | Small | GOODCONBUG | 22.00 |
| 509-K | 0.005 μ f | 500 | 500 ke | 0.035 μ h | 0.020 Ω | Small | GOODCONCAT | 22.00 |
| 509-L | 0.01 μ f | 500 | 250 ke | 0.035 μ h | 0.020 Ω | Small | GOODCONDOG | 22.00 |
| 509-M | 0.02 μ f | 500 | 125 ke | 0.035 μ h | 0.020 Ω | Small | GOODCONEYE | 24.00 |
| 509-R | 0.05 μ f | 500 | 80 ke | 0.040 μ h | 0.025 Ω | Large | GOODCONPIG | 26.00 |
| 509-T | 0.1 μ f | 500 | 40 ke | 0.040 μ h | 0.025 Ω | Large | GOODCONROD | 28.00 |
| 509-U | 0.2 μ f | 500 | 20 ke | 0.040 μ h | 0.025 Ω | Large | GOODCONSIN | 35.00 |
| 509-X | 0.5 μ f | 500 | 8 ke | 0.040 μ h | 0.025 Ω | Large | GOODCONSUM | 42.00 |
| 509-Y | 1.0 μ f | 500 | 4 ke | 0.050 μ h | 0.030 Ω | Large | GOODCONTOP | 70.00 |

(Left) Change in capacitance as a function of frequency. These changes are referred to the values the capacitors would have if there were no interfacial polarization and no series inductance. Since the capacitors are adjusted to their nominal values at 1 ke, the 1-ke values on the plot should be used as a basis of reference in estimating the frequency error.

(Right) Dissipation factor as a function of frequency.

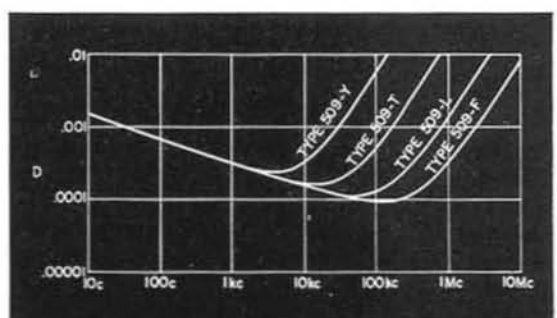
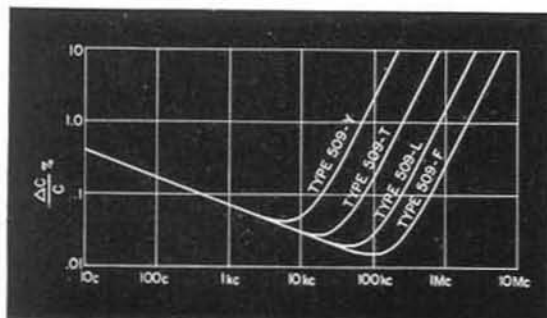

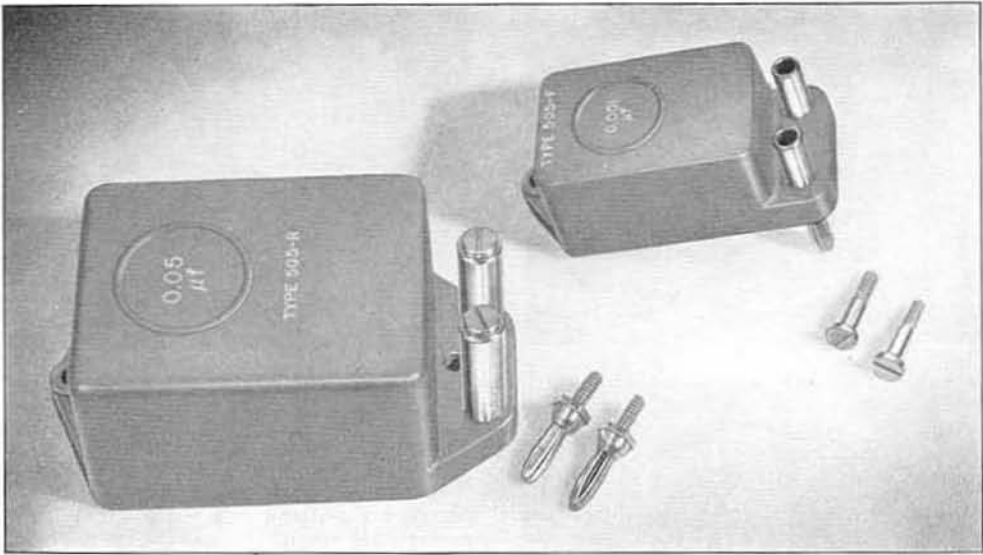

TYPE 505 CAPACITOR

USES: The TYPE 505 Capacitors are convenient and accurate plug-in units, which can be used as secondary laboratory standards and circuit elements in all types of equipment. An assortment of various sizes is indispensable to any communications laboratory.

DESCRIPTION: The capacitor unit consists of a mica and foil pile, which is held by a heavy metal clamp. This clamp is not connected to either capacitor terminal but is left floating. After aging, the capacitor unit is placed in the low-loss phenolic case, surrounded by silica gel and ground cork, and then covered with paper and sealed with wax.

FEATURES: ▶ The TYPE 505 Capacitors are small, accurate, and convenient to use. Both screw and plug-type terminals are furnished.

With the plug terminals different units can be stacked in parallel without cumulative connection errors.

- ▶ India mica with excellent electrical characteristics is used, and each piece is inspected for mechanical defects and imperfections which might cause large dielectric losses.
- ▶ The mounting method used reduces the temperature coefficient of capacitance to a low value and makes the dissipation factor independent of humidity.
- ▶ Moisture is eliminated by heating each unit before sealing. Any moisture that may collect after the capacitor is in use for some time is absorbed by silica gel in the case.
- ▶ Low-loss (yellow) phenolic cases are used to insure low dissipation factor and low leakage conductance.

SPECIFICATIONS

Capacitance: Twelve sizes are listed in the price table.

Accuracy of Adjustment: All units are adjusted within 1% or 10 μf , whichever is the larger.

Temperature Coefficient: The temperature coefficient of capacitance is less than +0.01% per degree Centigrade between 10° and 50° Centigrade.

Dissipation Factor: The dissipation factor of all units, except the three smallest sizes, measured at 1 kc and at 25° Centigrade, is less than 0.0005. Because of the increasing effect of dielectric losses in the phenolic case on the dissipation factor as the capacitance decreases, the dissipation factor, at 1 kc and 25° Centigrade, of the TYPES 505-A, 505-B, and 505-E is less than 0.0010, 0.0008, and 0.0006, respectively. A change of about

+5% of its value occurs in the dissipation factor for a temperature rise of 1° Centigrade.

Frequency Characteristics: The effective terminal capacitance is essentially constant over a wide frequency range. At low frequencies there is an increase in capacitance because of interfacial polarization (dielectric absorption) in the mica. At high frequencies there is also an increase because of residual inductance in the leads and terminals, amounting on the average to 0.055 μh for the capacitors mounted in the small cases and 0.085 μh for capacitors mounted in the large cases. The percentage change in capacitance with frequency for representative sizes of TYPE 505 Capacitors is shown in the accompanying plot.

CAPACITORS

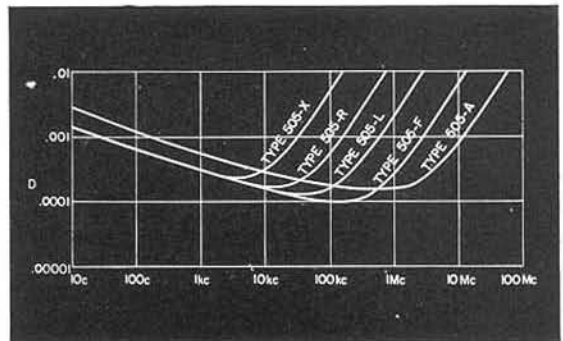
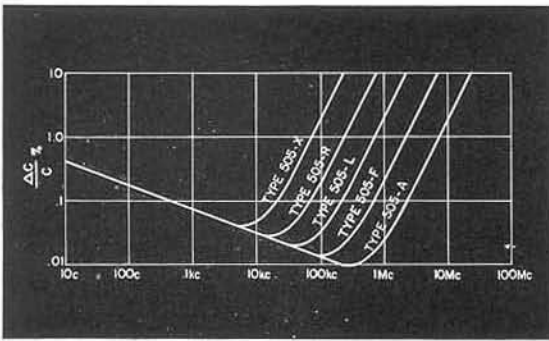

(Left) Change in capacitance as a function of frequency. These changes are referred to the values which the capacitors would have if there were neither interfacial polarization nor series inductance. Since the capacitors are adjusted to their nominal values at 1 kc, the 1-ke value on the plot should be used as a basis of reference in estimating frequency errors.
(Right) Dissipation factor as a function of frequency.

The change in dissipation factor with frequency is also shown in one of the accompanying plots. At low frequencies there is an increase in dissipation factor because of interfacial polarization in the mica. At high frequencies there is also an increase caused by series resistance in the leads and terminals. This resistance varies with the square root of the frequency for frequencies above 100 kc and has at 1 Mc an average value of 0.03 ohm for capacitors mounted in the small cases and 0.05 ohm for capacitors mounted in the large cases.

Leakage Resistance: The leakage resistance, when measured at 500 volts, is greater than 100,000 megohms, except for the TYPES 505-U and 505-X. In these units, the resistance is greater than 50,000 and 20,000 megohms, respectively.

Maximum Voltage and Frequency: The maximum peak voltage which the capacitors will safely withstand is 500 volts for all but the two smallest units, which will withstand 700 volts peak. These ratings hold up to the limiting frequencies tabulated below. At higher frequencies the allowable voltage decreases and is inversely proportional to the square root of the frequency. These limits correspond to a temperature rise of 40° Centigrade for a power dissipation of 1 watt for the small case and 2.5 watts for the large case.

| Type | Frequency |
|-------|-----------|
| 505-A | 2000 kc |
| 505-B | 1000 kc |
| 505-E | 1000 kc |
| 505-F | 800 kc |
| 505-G | 400 kc |
| 505-K | 160 kc |
| 505-L | 80 kc |
| 505-M | 40 kc |
| 505-R | 40 kc |
| 505-T | 20 kc |
| 505-U | 10 kc |
| 505-X | 4 kc |

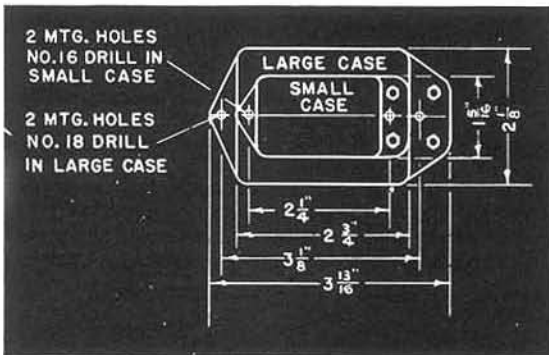

Terminals: Screw terminals spaced 3/4 inch apart. Two TYPE 274-P Plugs are supplied with each capacitor so that it may be converted to a plug-terminal model.

Mounting: Low-loss (yellow) phenolic cases.

Dimensions: See sketch. Over-all height, 1 5/8 inches for large case, 1 inch for small case, exclusive of plugs.

Net Weight: 4 ounces.

| Type | Capacitance | Code Word | Price |
|--------|-------------|------------|---------|
| 505-A | 100 μμf | CONDENALLY | \$ 5.00 |
| 505-B | 200 μμf | CONDENBELL | 5.00 |
| 505-E | 500 μμf | CONDENCOAT | 5.50 |
| 505-F | 0.001 μf | CONDENDRAM | 5.50 |
| 505-G | 0.002 μf | CONDENEYRE | 5.50 |
| 505-K | 0.005 μf | CONDENFACT | 6.50 |
| 505-L | 0.01 μf | CONDENGIRL | 6.50 |
| 505-M | 0.02 μf | CONDENHEAD | 8.50 |
| *505-R | 0.05 μf | CONDENCALM | 10.00 |
| *505-T | 0.1 μf | CONDENCROW | 14.00 |
| *505-U | 0.2 μf | CONDENWIPE | 20.00 |
| *505-X | 0.5 μf | CONDENWILT | 32.00 |

*Mounted in large case.



TYPE 219 DECADE CONDENSER

USES: The TYPE 219 Decade Condensers find uses in every laboratory as tuned circuit elements, bridge impedances, filter elements, or as components of any circuit where a wide-range variable capacitor is necessary.

DESCRIPTION: The TYPE 219 Decade Condensers are assemblies of three TYPE 380 Decade-Capacitor Units mounted in a shielded cabinet. Each decade has eleven positions, 0 to 10 inclusive, so that the decades overlap. A positive detent mechanism allows the switch to be set accurately.

FEATURES: ▶ A wide range of direct-reading capacitance values is covered by the TYPE 219 Decade Condensers.

▶ Accuracy is sufficient for most laboratory work, although the boxes have not been designed as standards.

▶ The zero capacitance has been kept at a minimum and its value is marked on each box for ready reference.

▶ Dissipation factor has been held low by employing mica-dielectric capacitors on all decades except the 0.1-microfarad decade of the TYPE 219-M.

▶ Mica dielectric is used throughout the TYPE 219-K, which can therefore be used where the comparatively high losses of paper capacitors cannot be tolerated.

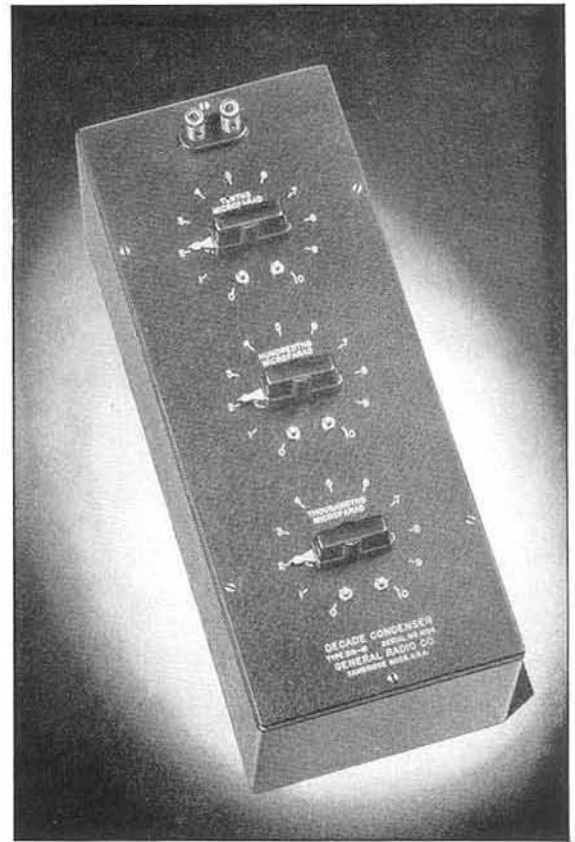

SPECIFICATIONS

Accuracy: All units are accurate at the decade terminals within $\pm 1\%$, except the 0.1-microfarad decade of the TYPE 219-M which is within $\pm 2\%$. To obtain these accuracies at the box terminals, account must be taken of the effective zero capacitance of the box, which is made up of the true zero capacitance and the mutual capacitance between units. The values for the different boxes follow:

| Type | Effective Zero Capacitance |
|-------|----------------------------|
| 219-K | 35 μf |
| 219-M | 30 μf |

These values are engraved on the Instruction Plate on every box.

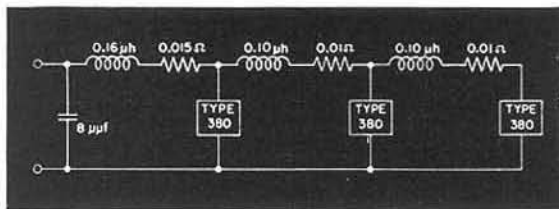

Residual impedances in the TYPE 219 Decade Condenser.

Dissipation Factor: The dissipation factor for the individual decades is given in the specifications for the TYPE 380 Decade-Capacitor Units. For the three lowest steps of the thousandths-microfarad decades, the tabulated values will be exceeded because of losses in the zero capacitance.

Maximum Voltage and Frequency: These values for the different decades are given in the specifications for the TYPE 380 Decade-Capacitor Units. The limiting values for the different TYPE 219 Decade Condensers are engraved on the Instruction Plate for each box.

Frequency Characteristics: The variation of capacitance and dissipation factor with frequency is similar to that shown on page 55 for TYPE 380 Decade-Capacitor Units, modified by the additional residual impedances shown in the accompanying sketch. Detailed descriptions of these frequency characteristics are given in the *General Radio Experimenter*, Vol. XVII, No. 5, October, 1942.

Terminals: Standard jack-top binding posts with a $\frac{3}{4}$ -inch spacing are used. The shield is connected to the "G" terminal.

Mounting: The decades are assembled on an aluminum panel and mounted in a shielded walnut cabinet.

Dimensions: TYPES 219-K and 219-M, (length) $13\frac{3}{4}$ x (width) $5\frac{1}{2}$ x (height) $5\frac{3}{8}$ inches.

Net Weight: TYPE 219-K, $10\frac{3}{4}$ pounds; TYPE 219-M, $8\frac{5}{8}$ pounds.

| Type | Capacitance | No. of Dials | Type 380 Decades Used | Code Word | Price |
|-------|--|--------------|-----------------------|-----------|----------|
| 219-K | 1.110 μf in 0.001 μf steps | 3 | F, M, N | CROSS | \$135.00 |
| 219-M | 1.110 μf in 0.001 μf steps | 3 | L, M, N | BRIER | 70.00 |

CAPACITORS

TYPE 380 DECADE-CAPACITOR UNIT



TYPE 380-M.

TYPE 380-F.

USES: The TYPE 380 Decade-Capacitor Units are extremely useful as elements in tuned circuits, wave filters, and other experimental or permanent equipment where a rather large variable capacitance is desired. They are also useful in oscillators, analyzers, amplifiers, and similar apparatus, especially during the preliminary design period when capacitance values are to be determined by experiment.

DESCRIPTION: Each decade is an assembly of four individual mica or paper capacitors. A selector switch is arranged to make parallel combinations of the units so that any one of ten values may be obtained.

The switch is of rigid construction and carries a detent mechanism for positive location of the switch positions. A phenolic shaft is used and contact is made by means of cams bearing on phosphor-bronze springs. A brass shaft bushing is molded in. This switch together with dial plate and knob is available separately as the TYPE 380-P3. (See price list.)

All standard units are furnished complete with knob, photo-etched dial plate, and stops.

FEATURES: ▶ Stability of the TYPE 380 Decade-Capacitor Units is obtained by careful selection and ageing of the component capacitors.

▶ Molded mica capacitors are used on the smaller decades while the TYPE 380-F employs TYPE 505 Capacitors.

▶ Thorough impregnation during winding, with molten ceresin, is given the paper capacitors used in the TYPE 380-L. A non-inductive type of winding is used, with the foil projecting at each end of the roll, thus avoiding the large increases in dissipation factor and capacitance that occur at high frequencies when only the one end of each foil is connected.

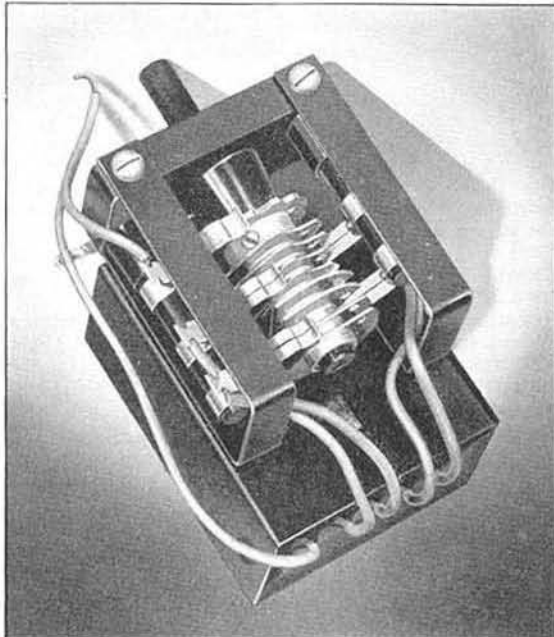

(Left) Rear View of TYPE 380-M.

SPECIFICATIONS

Accuracy: All units are within $\pm 1\%$ when measured at 1 kc except the TYPE 380-L, which is accurate within $\pm 2\%$. The units are checked with the switch mechanism high, electrically, and the common lead and case grounded.

Dielectric: The TYPE 380-F is made up of TYPE 505 Capacitors which have mica as the dielectric. The TYPE 380-L uses ceresin-impregnated linen-paper capacitor units while the TYPE 380-M and TYPE 380-N use mica capacitors molded in phenolic cases.

Dissipation Factor: The dissipation factor of the different units, when measured at 1 kc and 25° Centigrade, will be less than the values in the following table, with the exception of the three lowest settings of the TYPE 380-N. Here, because of the losses in the switch and mounting, the tabulated dissipation factor may be exceeded by a slight amount.

| Type | Dissipation Factor |
|-------|--------------------|
| 380-F | 0.0005 |
| 380-L | 0.010 |
| 380-M | 0.0010 |
| 380-N | 0.0025 |

Frequency Characteristics: The variation of capacitance and dissipation factor with frequency is shown in the accompanying plots. The rise in capacitance at low frequencies is caused by interfacial polarization in the dielectric, that at high frequencies by series inductance. The dissipation factor also rises at low frequencies because of interfacial polarization and at high frequencies because of series resistance in the leads. Values for the residual parameters are given in the *General Radio Experimenter*, Vol. XVII, No. 5, October, 1942.

Maximum Voltage and Frequency: The maximum peak voltage which the units will safely withstand is 300 volts, with the exception of the TYPE 380-F which will withstand 500 volts. These voltages hold up to the limiting frequencies tabulated below. At higher frequencies the allowable voltage decreases and is inversely proportional

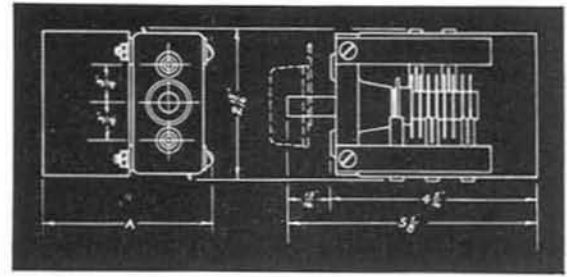

Over-all dimensions of TYPES 380-L, -M, and -N Decade-Capacitor Units; dimension A is $3\frac{5}{16}$ inches. While TYPE 380-F uses the same switch mechanism, capacitors are mounted on both sides of the switch and the panel space required is $4\frac{3}{4} \times 4\frac{3}{4}$ inches.

to the square root of the frequency. These limits correspond to a temperature rise of 40° Centigrade for a power dissipation of 2.5 watts for the TYPE 380-F and 3.5 watts for the other units.

| Type | Frequency |
|-------|-----------|
| 380-F | 5 kc |
| 380-L | 1 kc |
| 380-M | 100 kc |
| 380-N | 1000 kc |

Terminals: Flexible, rubber-insulated leads are provided. **Mounting:** Machine screws for attaching the decade to a panel are supplied.

Dimensions: TYPE 380-F, panel space, $4\frac{3}{4} \times 4\frac{3}{4}$ inches; behind panel, 4 inches. TYPES 380-L, 380-M, and 380-N, see accompanying sketch.

Net Weight: TYPE 380-F, 3 pounds, 12 ounces; TYPES 380-L and 380-M, $1\frac{1}{2}$ pounds; TYPE 380-N, 1 pound, 6 ounces.

| Type | Capacitance | Code Word | Price |
|--------|--|------------|---------|
| 380-F | 1.0 μf in 0.1 μf steps..... | ACUTE | \$80.00 |
| 380-L | 1.0 μf in 0.1 μf steps..... | ADAGE | 15.00 |
| 380-M | 0.1 μf in 0.01 μf steps..... | ADDER | 22.00 |
| 380-N | 0.01 μf in 0.001 μf steps..... | ADDLE | 15.00 |
| 380-P3 | Switch Only..... | SWITCHFORD | 8.25 |

(Left) Change in capacitance at maximum setting of each decade as a function of frequency. The capacitance curves are referred to the value the capacitor would have if there were no interfacial polarization and no series inductance. Since the capacitors are adjusted to their rated accuracy at 1 kc, the 1 kc value on the plots should be used as a basis of reference in estimating the frequency error.

(Right) Dissipation factor as a function of frequency.

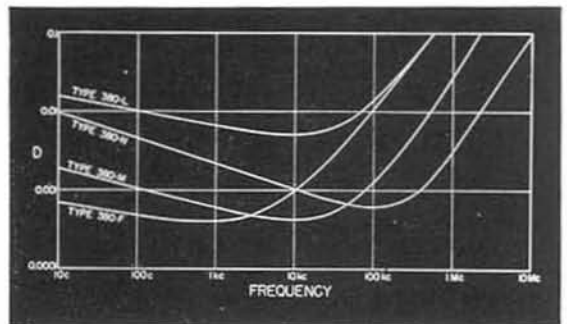
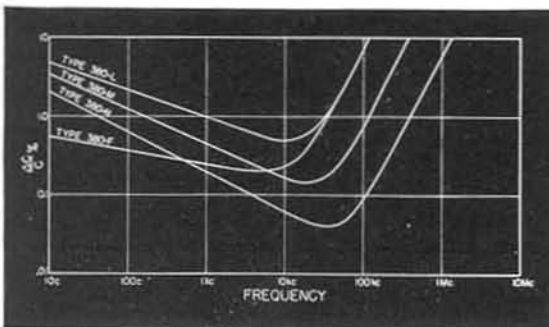

INDUCTORS

TYPE 940 DECADE-INDUCTOR UNIT

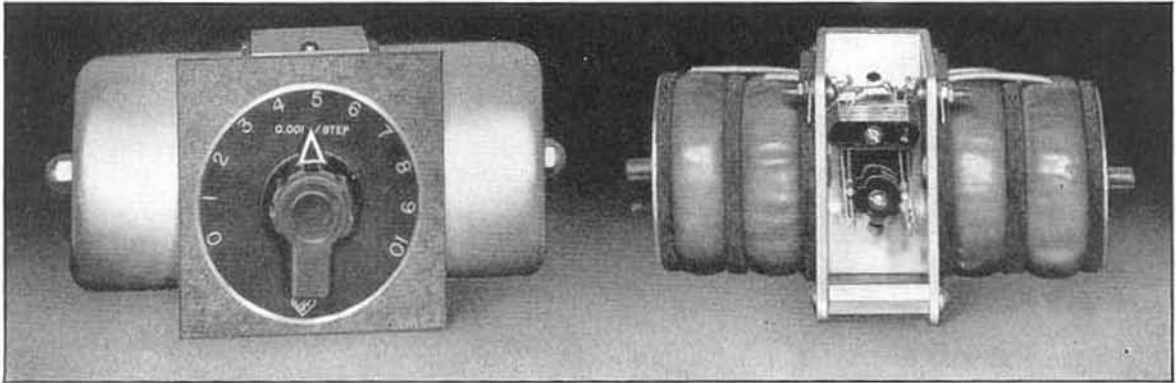

USES: The TYPE 940 Decade-Inductor Units are convenient elements for use in wave filters and tuned circuits throughout the audio and low radio-frequency range. As components in oscillators, analyzers, and similar equipment, they are especially useful during the preliminary design period when the ability to vary circuit elements over relatively wide ranges is necessary to determine optimum operating values. As moderately precise standards of inductance they have storage factor Q values which are much larger than can be obtained with air-cored coils.

DESCRIPTION: Each unit is an assembly of four toroids wound on molybdenum-permalloy dust cores. All four coils (relative values 1, 2, 2, 5) are connected in series, and the switch, a modified TYPE 920, short-circuits

combinations of the coils to give the eleven successive values from 0 to 10. The switch blades are phosphor bronze with silver overlay to decrease both contact and volume resistance.

FEATURES: ▶ High values of storage factor Q are obtained in all models, with maximum values over 200.

▶ Toroidal construction practically eliminates any external magnetic field, and makes it possible to stack the coils closely without trouble from mutual inductances. The toroids are nearly astatic to external magnetic fields.

▶ Electrostatic shielding and mechanical protection are furnished by the aluminum frame and covers.

▶ Moisture is kept from the windings by wax impregnation.

SPECIFICATIONS

Accuracy: Each unit is adjusted so that its inductance at zero frequency and initial permeability will be the nominal value within the accuracy tolerance given in the following table:

| Inductance per step | 1 mh | 10 mh | 100 mh | 1 h |
|---------------------|------|-------|--------|--------|
| Accuracy | ±2% | ±1% | ±0.5% | ±0.25% |

Frequency Characteristics: The equivalent inductance of these units in terms of the nominal inductance L is given by the following equation:

$$L \text{ (equivalent)} = \frac{L}{1 - \omega^2 C_0 L}$$

Typical values for the distributed capacitance C_0 of the TYPE 940-A Decade-Inductor Unit are as follows:

| Step | 1 | 2 | 3 | 4 | 5 | 6 | 7 | 8 | 9 | 10 |
|--|----|----|----|----|----|----|----|----|----|----|
| C_0 (μmf); Chassis tied to Low Terminal | 90 | 60 | 50 | 50 | 50 | 45 | 40 | 37 | 35 | 35 |
| C_0 (μmf); Chassis Floating | 45 | 45 | 35 | 35 | 50 | 40 | 35 | 32 | 30 | 25 |

For the TYPES 940-B, -C, and -D the above values should be multiplied by the factors 1.1, 1.25, and 1.5 respectively.

Current Characteristics and Maximum Current Ratings: The core permeability and the inductance value of each toroid are raised 0.1% by the application

of 1.20 ampere turns. The corresponding r-m-s current values I_1 for each of the toroids are listed below, together with the r-m-s current values I_2 corresponding to a safe heat dissipation of two watts per toroid.

| Inductor | Toroid | I_1 (ma) for 0.1% increase | I_2 (amp) |
|----------|--------|------------------------------|-------------|
| 940-A | 1 mh | 15.1 | 7.2 |
| 940-A | 2 mh | 10.7 | 5.2 |
| 940-A | 5 mh | 6.8 | 3.0 |
| 940-B | 10 mh | 4.8 | 2.3 |
| 940-B | 20 mh | 3.4 | 1.7 |
| 940-B | 50 mh | 2.1 | 1.0 |
| 940-C | 100 mh | 1.51 | 0.72 |
| 940-C | 200 mh | 1.07 | 0.52 |
| 940-C | 500 mh | 0.68 | 0.30 |
| 940-D | 1 h | 0.48 | 0.23 |
| 940-D | 2 h | 0.34 | 0.17 |
| 940-D | 5 h | 0.21 | 0.10 |

Currents of about $6 I_1$ will produce 0.5% increase in inductance; $25 I_1$ gives 1% increase; about $45 I_1$ gives a maximum increase of 2%, while still larger currents



produce a drop in inductance, the error being zero at about 100 I_1 . The I_2 values may reduce L to about 70% of its initial value.

Dissipation Factor: The accompanying plot shows the variation of the dissipation factor $D = 1/Q$ with frequency for the full value of each inductor (see page 43). It will be seen that maximum storage factor Q values between 200 and 330 are obtained at frequencies between 2 and 5 kc.

Temperature Coefficient: The temperature coefficient of inductance is about +50 parts per million per degree Centigrade.

Maximum Voltage: The maximum r-m-s voltage for which the units are insulated is 500 volts. The switch will break the circuit at 500 volts if turned rapidly to the new setting, but voltages above 150 may cause destructive arcing if the switch is set between detent positions.

Terminals: Soldering lugs are provided.

Mounting: Each decade is complete with dial plate, knob, and mounting screws.

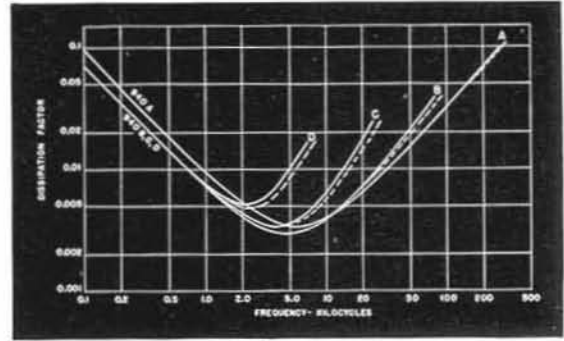

Variation of dissipation factor for the full value of each inductor. Dashed curves correspond to use with chassis floating.

Dimensions: (Width) $7\frac{1}{4}$ x (height) $3\frac{1}{2}$ x (depth behind panel) $3\frac{1}{4}$ inches, over-all.

Net Weight: $3\frac{1}{2}$ pounds.

| Type | Inductance | Code Word | Price |
|-------|-------------------------|------------|------------------|
| 940-A | 0.01 h in 0.001 h steps | INDUCTOANT | Price on Request |
| 940-B | 0.1 h in 0.01 h steps | INDUCTOBOY | |
| 940-C | 1 h in 0.1 h steps | INDUCTOCAT | |
| 940-D | 10 h in 1 h steps | INDUCTODOG | |

TYPE 1490 DECADE INDUCTOR

USES: Where an adjustable inductance covering a very wide range is required these boxes will be extremely useful.

DESCRIPTION: The TYPE 1490 Decade Inductor is an assembly of three or four TYPE 940 Decade-Inductor Units in a single metal cabinet. The units have no electrical connection to the panel but a separate ground terminal is provided which may be connected to the "low" terminal of the smallest unit.

SPECIFICATIONS

Frequency Characteristics: In determining the correction factor $\omega^2 C_0 L$ use the C_0 value corresponding to the largest decade unit actually in circuit. For each larger decade unit not in circuit add $100 \mu\text{f}$ if the inductor is grounded to the panel or add $20 \mu\text{f}$ if the inductor is not grounded to the panel.

Terminals: Jack-top binding posts.

Mounting: The decades are mounted on an aluminum panel in a metal cabinet.

Dimensions: 1490-A $12\frac{3}{4}$ x $7\frac{3}{4}$ x $5\frac{1}{2}$ inches over-all height. 1490-B $16\frac{1}{2}$ x $7\frac{3}{4}$ x $5\frac{1}{2}$ inches over-all height.

Net Weight: TYPE 1490-A, 15 pounds; TYPE 1490-B, 19 pounds.

Other specifications are identical with those for the TYPE 940-Decade-Inductor Units.

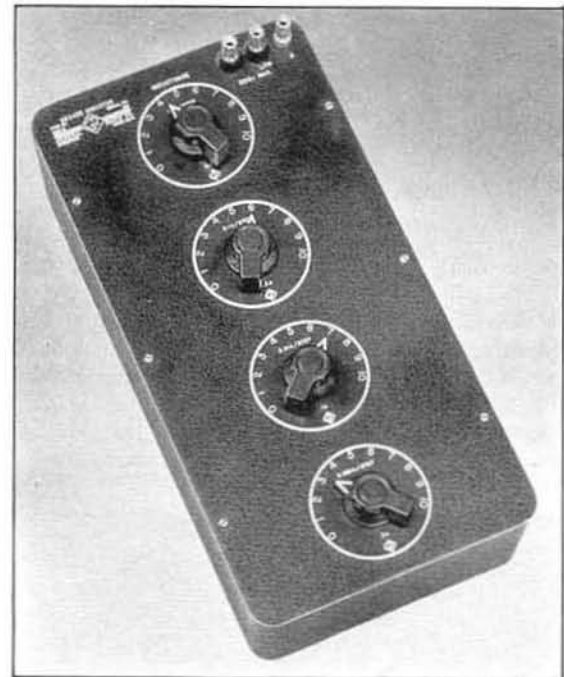

| Type | Inductance | Code Word | Price |
|--------|----------------------------------|-----------|------------------|
| 1490-A | 1 h, total, in steps of 0.001 h | CLUMP | Price on Request |
| 1490-B | 10 h, total, in steps of 0.001 h | COACH | |



TYPE 107 VARIABLE INDUCTOR

USES: The TYPE 107 Variable Inductors find their greatest uses in the laboratory as standards of moderate accuracy for measurements of self- and mutual inductance, and as components of bridges, oscillators, and similar equipment where a variable inductor is needed as a circuit element.

DESCRIPTION: Two coils, a rotor and a stator, are mounted concentrically. As the position of the rotor is changed the coupling between the two coils changes, and the inductance is varied.

In most models stranded wire is used, in which the separate strands are insulated from one another. The coils are impregnated and baked in a high-melting-point material before being securely mounted to the phenolic panel.

FEATURES: ▶ Direct reading in inductance for both series and parallel connections of the

coils, each TYPE 107 Variable Inductor covers a total inductance range of over 25:1.

▶ Rotor and stator inductances have been carefully equalized, and the coils are so mounted that the inductance for the parallel connection is exactly one-fourth the value shown by the dial for the series connection. This equalization of the two coils also eliminates losses from circulating currents when the parallel connection is used.

▶ Separate terminals are brought out for both rotor and stator so that they may be quickly connected in either series or parallel as a self-inductor, or used separately as a mutual inductor. The formula for the mutual inductance is given on the nameplate, together with the value of d-c resistance and maximum current.

SPECIFICATIONS

Self-Inductance Range: Five sizes are listed covering a total range of approximately 2 microhenrys to 500 millihenrys by the use of both the series and parallel connections. Maximum and minimum values for both connections are shown in the price list.

Mutual Inductance: Either positive or negative values of mutual inductance can be obtained. The exact formula for the mutual inductance is engraved on each individual instrument. The approximate ranges are given in the table below.

Calibration: The inductance for the series connection, measured at 1 ke and accurate within $\pm 1\%$ of full-scale reading, is engraved on the dial. The inductance for the parallel connection is within $\pm 0.1\%$ of one-fourth of the series inductance.

The mutual inductance accuracy is $\pm 2.5\%$ of the maximum mutual inductance value.

Frequency Error: Disregarding errors due to skin effect, the fractional change in inductance with frequency will be f^2/f_0^2 where f is the operating frequency and f_0 the natural frequency. Accordingly, at one-tenth the natural frequency, the frequency error is but 1%. At higher frequencies skin effect errors, which are different for the different units, may become appreciable. The table below gives the natural frequencies for the different standard units, for full setting with series connection.

Losses: The maximum value of the storage factor $Q = \frac{X}{R}$ for full-scale setting with the series connection is given in the table for each inductor together with the frequency at which this value of Q is obtained. The change of dissipation factor $D = \frac{1}{Q}$ with frequency is shown in the plot below.

Maximum Power and Current: The total amount of power which each inductor is capable of dissipating is 15 watts. This amount causes a temperature rise of 40° Centigrade.

The maximum allowable current for the series connection, is given below in the table and is engraved on each nameplate.

Direct-Current Resistance: The approximate values of d-c resistance for the different units are given in the table and are also engraved on the nameplates of the instruments.

Terminals: Standard 3/4-inch spacing, jack-top binding posts are provided which allow separate connections to rotor and stator. Connecting links are supplied so that either a series or parallel connection of the rotor and stator can be made available at a third pair of binding posts.

Mounting: All units are mounted on phenolic panels and enclosed in walnut cabinets.

Dimensions: 6 1/2 x 6 1/2 x 8 3/4 inches, over-all.

Net Weight: 5 pounds, all ranges.

| Type | Mutual Inductance | D-C Resistance | Maximum Current | Maximum Q* | Frequency for Maximum Q* | Natural Frequency* |
|-------|-------------------|----------------|-----------------|------------|--------------------------|--------------------|
| 107-J | 0-10.8 μ h | 0.05 Ω | 16. a | 140 | 270 ke | 3700 ke |
| 107-K | 0-110 μ h | 0.38 Ω | 6. a | 140 | 130 ke | 1100 ke |
| 107-L | 0-1.1 mh | 4.6 Ω | 1.7 a | 140 | 60 ke | 360 ke |
| 107-M | 0-11 mh | 32 Ω | 0.65 a | 100 | 25 ke | 130 ke |
| 107-N | 0-110 mh | 410 Ω | 0.18 a | 60 | 15 ke | 35 ke |

*For full-scale setting, series connection.

| Type | Self-Inductance | | Code Word | Price |
|-------|-----------------|----------------|-----------|---------|
| | Series | Parallel | | |
| 107-J | 8- 50 μ h | 2-12.5 μ h | HAREM | \$50.00 |
| 107-K | 80-500 μ h | 20-125 μ h | HARPY | 50.00 |
| 107-L | 0.8- 5 mh | 0.2-1.25 mh | HARRY | 50.00 |
| 107-M | 8- 50 mh | 2-12.5 mh | HOTEL | 55.00 |
| 107-N | 80-500 mh | 20-125 mh | HOVER | 55.00 |

Dissipation factor ($D = 1/Q$) versus frequency for (left) TYPE 106 Standard Inductances, and (right) TYPE 107 Variable Inductors for the full-scale series connection.

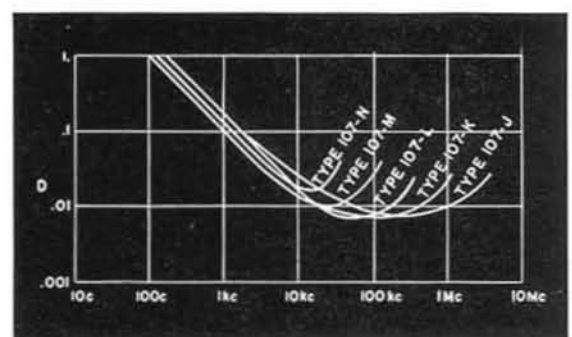
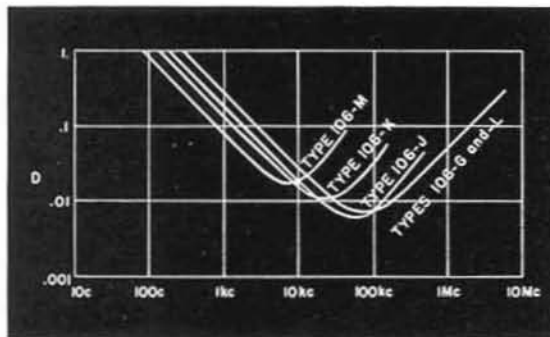

INDUCTORS

TYPE 106 STANDARD INDUCTANCE



USES: The Type 106 Standard Inductance is an accurate standard of self-inductance for

use in bridge and other measurements at audio frequencies.

DESCRIPTION: An astatic form of mounting is used wherein two D-shaped coils are mounted parallel to each other. The coils are form wound, bound with tape, and impregnated with wax before being mounted. A minimum of metal is used in the mounting, thus minimizing variations in inductance with frequency.

FEATURES: ▶ Low and nearly constant resistance at audio frequencies is insured by the use, wherever practicable, of stranded wire in which the separate strands are insulated from one another.

▶ The inductance has been made independent of surroundings by using an astatic form of mounting in which the fields of the two coil sections neutralize each other in regions external to the case. Thus, interaction between external fields and the field of the inductor is reduced to a minimum.

SPECIFICATIONS

| Type | Nominal D-C Resistance | Maximum Power | Maximum Current | Maximum Q | Frequency for Maximum Q | Natural Frequency |
|-------|------------------------|---------------|-----------------|-----------|-------------------------|-------------------|
| 106-L | 0.18 Ω | 5 w | 5.0 a | 210 | 300 ke | 6000 ke |
| 106-G | 1.80 Ω | 4 w | 1.4 a | 190 | 150 ke | 2000 ke |
| 106-J | 12.2 Ω | 6 w | .65 a | 170 | 60 ke | 500 ke |
| 106-K | 85.3 Ω | 6 w | .25 a | 80 | 20 ke | 150 ke |
| 106-M | 545 Ω | 14 w | .15 a | 40 | 7 ke | 35 ke |

Accuracy: All units are adjusted within $\pm 0.1\%$ at 1 ke.

Resistance: The resistance at 1 ke is the same as the d-c resistance. This resistance, together with the temperature, is entered on a certificate mounted on the bottom of the cabinet when the inductor is measured in the Standardizing Laboratory. The nominal values are given in the table above.

Temperature Coefficient: The temperature coefficient of inductance is less than $\pm 0.004\%$ per degree Centigrade.

Maximum Power and Current: See table.

Losses: The maximum value of the storage factor $Q = \frac{X}{R}$ and the frequency for which it occurs for each size are given in the table. The change of dissipation factor $D = \frac{1}{Q}$ with frequency is shown in the plot on page 59.

Frequency Error: Disregarding skin effect the fractional change in inductance with frequency is f^2/f_0^2 where f is operating frequency and f_0 the natural frequency. At one-tenth the natural frequency, therefore, the error is 1%.

Terminals: Binding posts are provided.

Mounting: All units are assembled in walnut cabinets with phenolic panels.

Dimensions: Panel, $5\frac{3}{8} \times 5\frac{3}{8}$ inches. Cabinet, (height) $3\frac{1}{2}$ inches, over-all, except Type 106-M which is $5\frac{3}{8}$ inches, over-all.

Net Weight: Approximately $2\frac{3}{8}$ pounds, except Type 106-M which is 5 pounds.

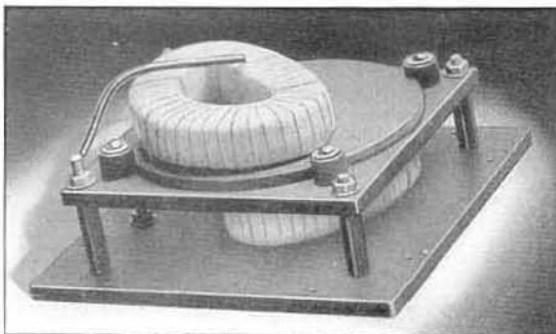

| Type | Inductance | Code Word | Price |
|-------|------------|-----------|---------|
| 106-L | 0.1 mh | INNER | \$33.00 |
| 106-G | 1 mh | INERT | 33.00 |
| 106-J | 10 mh | IRATE | 33.00 |
| 106-K | 100 mh | ISLET | 33.00 |
| 106-M | 1 henry | ISSUE | 45.00 |

BRIDGES



for measuring
CAPACITANCE
•
DISSIPATION FACTOR
•
INDUCTANCE
•
RESISTANCE
•
VACUUM-TUBE
CHARACTERISTICS

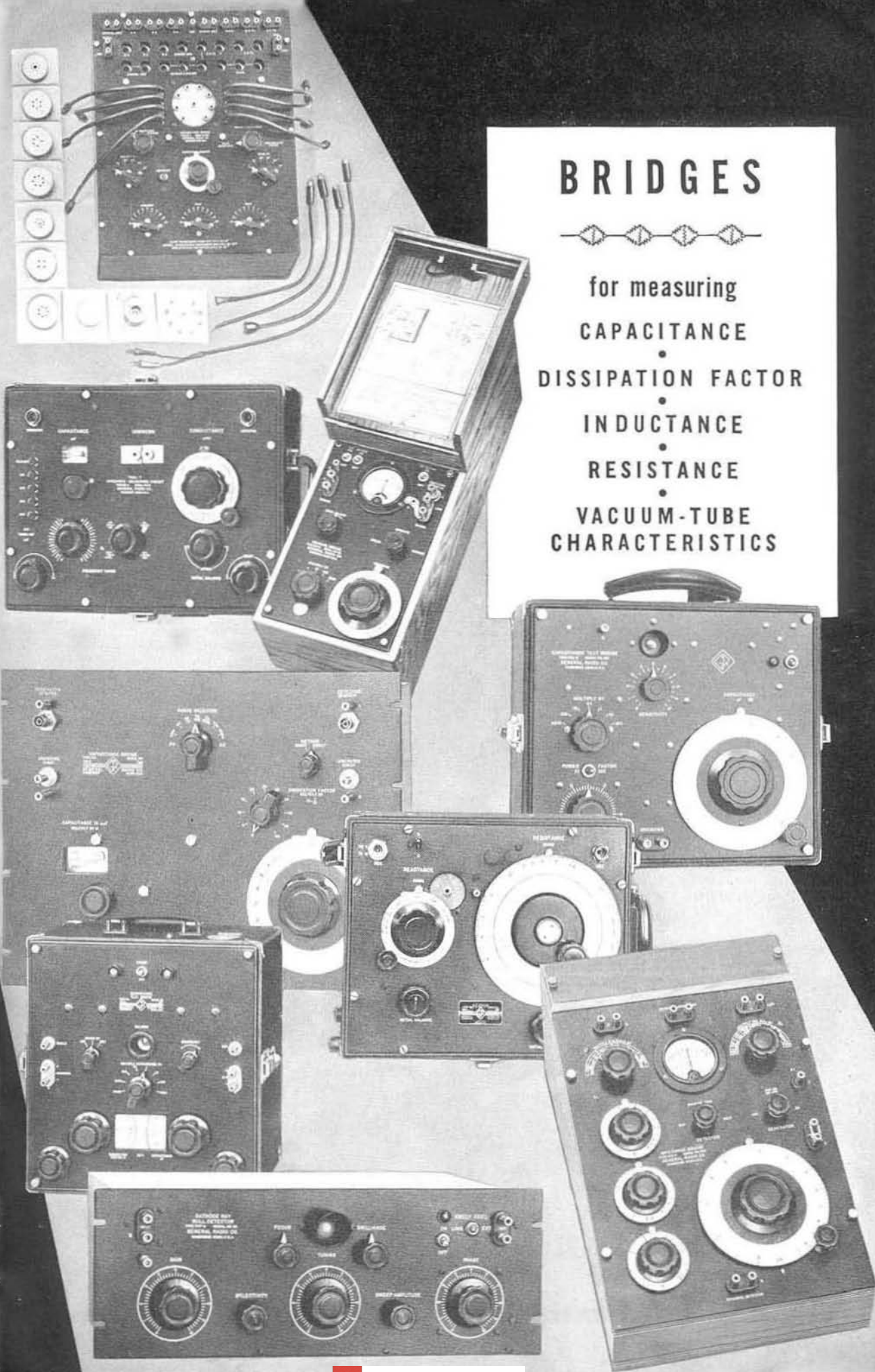

IMPEDANCE BRIDGES

For the measurement of all types of impedances, resistive or reactive, inductive or capacitive, the Wheatstone bridge circuit in its many modifications has proved best fitted on grounds of both accuracy and convenience.

The balance of the bridge is attained by a null method, that is, by reducing to zero the voltage between two opposite corners of the bridge. The precision of balance is not limited by the scale length of a deflecting instrument, but only by the voltage which can be applied to the bridge and by the sensitivity of the null detector. It is, therefore, possible to utilize completely the accuracy of the standards.

Because of the variety of possible bridge circuits, a bridge can usually be devised with controls that are made direct reading in any particular impedance or circuit characteristic. The direct-reading feature adds greatly to convenience in measurement, since it obviates laborious calculations which are always a bar to rapid work.

The fundamental bridge network is shown in Figure 1. The condition of balance is that the voltage across the detector be zero. This will occur when

$$\frac{A}{B} = \frac{N}{P} \text{ or } AP = BN \quad (1)$$

The four arms of the bridge are not necessarily simple impedances, but are frequently series and parallel combinations of resistance, inductance, and capacitance. Hence the bridge arms represented by the symbols used in Equation (1) are, in general, complex impedances, and there are two balance conditions, one for the resistive component and the other for the reactive component. The principal balance component of bridges designed specifically to measure inductance or capacitance should preferably be independent of frequency.

Usually, at least one of these balance con-

ditions varies with frequency, but no frequency limitation on the use of the bridge is inherent in the variation. Alternating-current bridges can be used at frequencies extending to tens of megacycles. The upper frequency limit for any particular design is set by the increasing effect of residual impedances in the various impedance standards and in the wiring.

BRIDGE CIRCUITS: Impedance bridges can be divided into two classes, the one in which like reactances are compared, and the other in which unlike reactances are compared. Both classes are illustrated in Figure 1. In bridges of the first class, referred to as inductance or capacitance bridges, arms *A* and *B* are resistance arms, while arms *N* and *P* are either both inductive or both capacitive, one arm containing the known standard, the other the unknown reactance. Of the bridges described in this section, TYPES 667, 716, 740, and 1611 are of this kind, the first being an inductance bridge, and the last three capacitance bridges. The TYPE 650 also falls in this class for the measurement of capacitance.

Bridges in the second class carry the names of their discoverers, Maxwell, Hay, Owen, and others. The inductance and capacitance arms are opposite one another. These circuits derive their greatest importance from the fact that they permit the measurement of inductance in terms of capacitance standards, which are generally superior to, and more convenient than, inductance standards. The TYPE 650 Impedance Bridge utilizes both the Maxwell and Hay circuits for the measurement of inductance.

The TYPE 544-B Megohm Bridge is a d-c Wheatstone bridge for high resistance measurements in which the detector is a vacuum-tube voltmeter, which has an extremely high input resistance.

FIGURE 1. Left, the general Wheatstone bridge circuit; center, circuit for a capacitance bridge in which like reactances, *N* and *P*, are compared; and, right, a circuit in which unlike reactances, *A* and *P*, are compared.

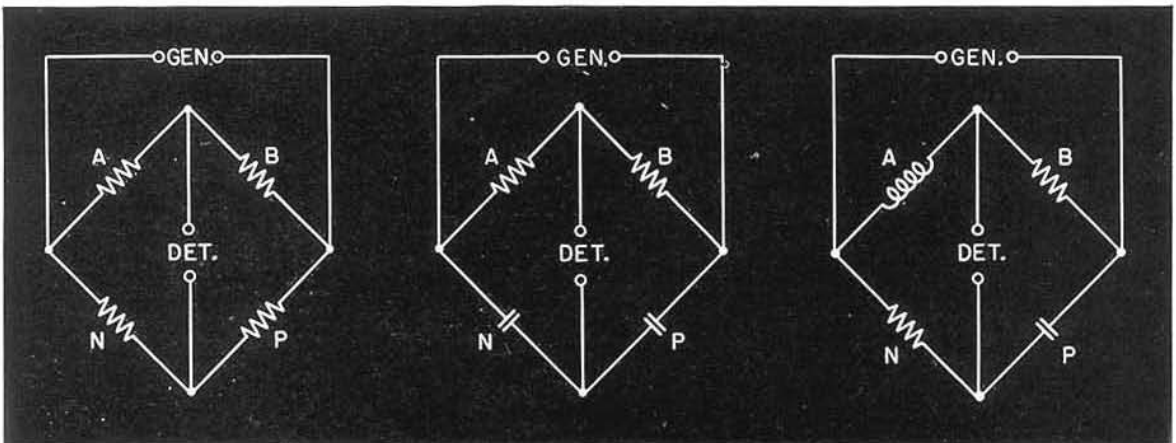

T-Networks: In addition to the bridge circuits described above there are a number of other networks which can be adjusted to give zero transmission for a particular configuration of circuit elements. One of these, the Twin-T or Parallel-T illustrated in Figure 2, has proved to be of great value for impedance measurements at high radio frequencies. This circuit is used in the TYPE S21 for impedance measurements from 0.5 to 40 megacycles.

Resistive Balance: All impedances have resistive components, and the bridges used for impedance measurement must be capable of measuring this resistance in some manner. Three methods are in general use: (1) series resistance, in which the balancing resistor is placed in series with the standard reactance; (2) parallel resistance, in which the balancing resistor is placed in parallel with the standard reactance; and (3) the Schering bridge in which a balancing capacitor is placed in parallel with the ratio arm opposite the unknown capacitor. The series resistance method is used in the TYPES 650, 740, 1611, and 667, while the TYPE 716 uses the Schering circuit for balancing the resistive component of impedance in terms of the dissipation factor. The TYPE 916 uses a new circuit in a series-substitution method with a fixed capacitor in the *N*-arm for reactance measurement. This arrangement makes possible the calibration of the capacitor across the *A*-arm in terms of the series resistance of the unknown, independent of frequency. The TYPES 716 and 650 are so constructed that the parallel resistance method can also be used.

In the Twin-T type of null-balance circuit that is used in the TYPE S21, the conductive component of the unknown is measured in terms of a fixed resistance and a variable capacitance, thus avoiding the errors inherent in variable resistors at high frequencies.

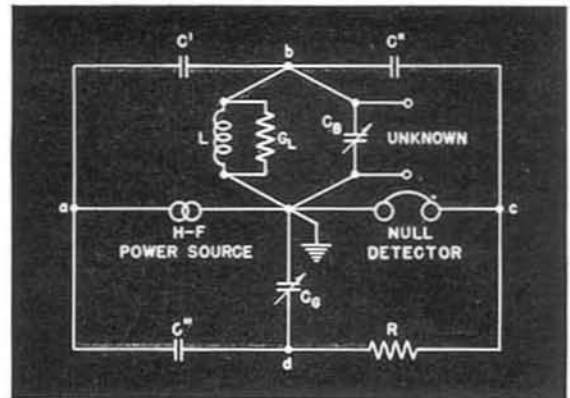

FIGURE 2. Parallel-T circuit for measuring impedance at radio frequencies.

Dissipation Factor and Storage Factor: Important characteristics of an inductor or a capacitor are the ratio of resistance to reactance and the ratio of conductance to susceptance. These ratios are termed dissipation factor, *D*, and storage factor, *Q*. They are reciprocal ratios defined as follows.

$$D = \frac{1}{Q} = \frac{R}{X} = \frac{G}{B} \quad Q = \frac{1}{D} = \frac{X}{R} = \frac{B}{G}$$

where *R* and *X* are the series resistance and reactance and *G* and *B* are the parallel conductance and susceptance of the impedance or admittance involved. Dissipation factor is directly proportional to the power dissipated and storage factor to the power stored. The relation of these factors to phase angle and loss angle is shown in Figure 4.

$$D = \frac{1}{Q} = \cot \theta = \tan \delta$$

Power factor is defined as

$$\text{P.F.} = \cos \theta = \sin \delta$$

and differs from dissipation factor by less than 1% when their values are less than 0.15.

FIGURE 3. Left, series resistance bridge; center, parallel resistance bridge; and, right, Schering bridge.

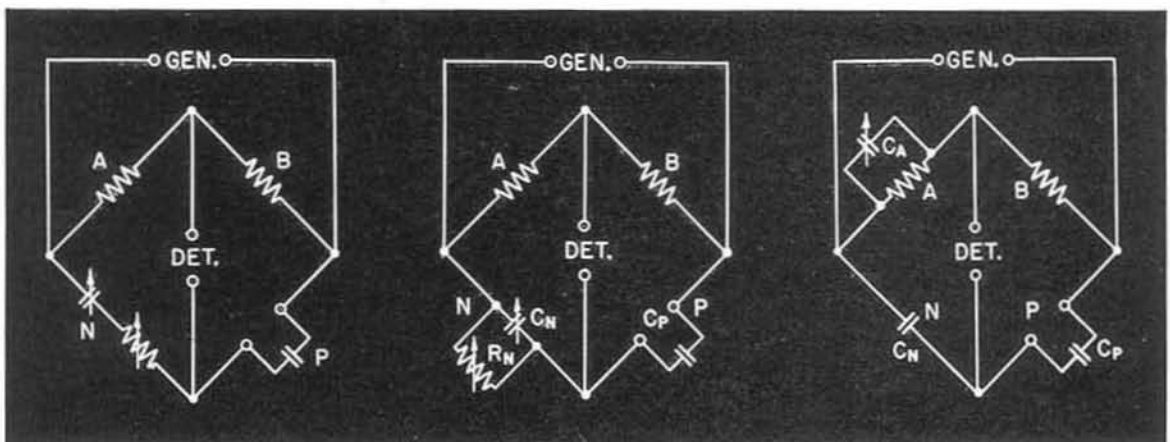

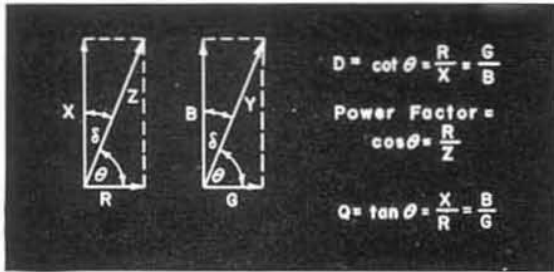

FIGURE 4. Vector diagram showing the relations between factors D and Q , and angles θ and δ .

Dissipation factor is commonly used for capacitors and, to a lesser extent, for inductors because it varies directly with the loss. Storage factor is often used for inductors because it measures the voltage step-up in a tuned circuit.

Where the Schering or series resistance method of resistive balance is used, the bridge can be calibrated in dissipation factor or in storage factor, for a given frequency. The TYPES 740 and 1611 have dials calibrated in dissipation factor at 60 cycles, and the TYPE 716 is direct reading at 100 cycles, 1, 10 and 100 kilocycles. The TYPE 650 reads directly the dissipation factor of capacitors and the storage factor of inductors, at 1000 cycles.

The TYPE 916 reads directly the series resistance of the unknown, independent of frequency, while the TYPE 821 is calibrated in parallel conductance for 1, 3, 10, and 30 megacycles.

ERRORS: A bridge circuit provides a means of comparing two impedances, an unknown and a standard. It does not provide an absolute measurement. The possible error in the measurement is always greater than the error in the standard itself by the errors in the other bridge arms entering into the comparison. If, for instance, the error in the standard and in each of the two ratio arms is $\pm 0.1\%$, there can then occur in the most unfavorable case an error of $\pm 0.3\%$ in the measurement. This accuracy limitation is common to all direct-reading bridges in which a result is obtained from a single balance of the bridge.

Substitution Method: The errors in three of the bridge arms can be eliminated from the measurement through the use of a substitution method in which the unknown impedance is connected in the standard arm. Two readings of the standard are required, one with the unknown disconnected and another with it connected. With an error in the standard of $\pm 0.1\%$, the maximum error of measurement is $\pm 0.2\%$. If auxiliary balances are provided so that the standard can always be

set initially at the same point, the error can be reduced almost to $\pm 0.1\%$.

Residual Impedances: The bridge equations derived from Equation (1) presuppose an accurate knowledge of the behavior of the impedances in each arm. No impedance element, however carefully constructed, is free from residual impedances. Resistors have series inductance and shunt capacitance. Inductors have relatively large series resistance and shunt capacitance. Even air capacitors, while more nearly perfect than other impedance standards, have resistive and inductive residual impedances. All of these extra impedances must be included in the values used for calculation in order to avoid error. The over-all residuals are greatly increased by the various connections forming the bridge circuit.

Shunt capacitance across the various arms is an important source of error even at audio frequencies. When capacitance occurs across a resistive arm, its effect on the resistive component of balance varies directly as the magnitude of the capacitance and directly as the operating frequency. Errors arising from this source account for the large differences between the listed errors in dissipation factor given for TYPE 650 and TYPES 740 and 1611 Bridges. TYPE 650 not only operates at a

FIGURE 5. The substitution method (shown for a capacitance measurement with a Schering bridge) reduces the error to essentially the accuracy with which the capacitance difference between two settings of the standard capacitor is known.

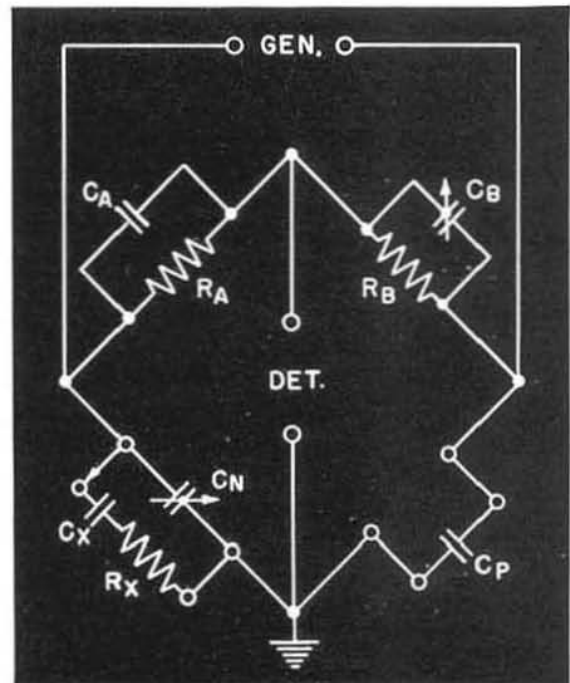

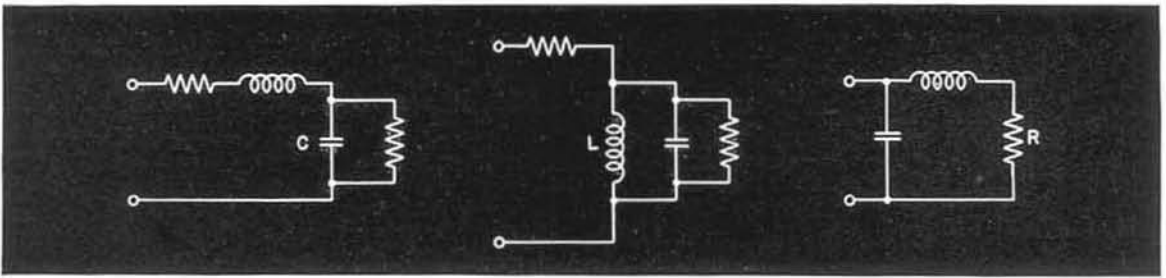

FIGURE 6. Schematic representation of capacitance, inductance, and resistance standards, showing the most important residual impedances. The ohmic resistance and inductance of the stacks and leads of the capacitor (left) are represented by series resistance and inductance, while the dielectric losses are represented by a shunt conductance. For an inductor (center), the copper losses consisting of both ohmic resistance and eddy currents, and the distributed capacitance with dielectric losses are the important residuals. A resistor (right), to a first approximation, is represented by an inductance in series, and a capacitance in shunt.

higher frequency but has unavoidable switching capacitances because it is designed for such a great variety of measurements.

Shunt capacitance across a reactive arm is also serious. In the TYPE 667-A Inductance Bridge the capacitance across the unknown terminals increases the error in the measured inductance from $\pm 0.2\%$ to $\pm 0.4\%$ on the highest multiplier. In the TYPE 716-C Capacitance Bridge complete shielding of the ratio arms reduces the capacitance across the unknown to less than $1 \mu\mu\text{f}$ (see Figure 9). The capacitance across the unknown terminals of the TYPES 650-A and 740-B are about $10 \mu\mu\text{f}$ and $3 \mu\mu\text{f}$ respectively. In the TYPE 1611-A the effect of the zero capacitance and its dissipation factor is eliminated by introducing across the detector terminals a voltage whose magnitude and phase is equal to the bridge unbalance voltage caused by this zero capacitance. Thus the bridge is made direct reading in capacitance and dissipation factor down to zero.

In the TYPE 916-A Radio-Frequency Bridge the equivalent shunt capacitance across the resistance arm has been reduced to less than $0.4 \mu\mu\text{f}$. This residual capacitance does not affect the resistive balance, and affects the reactance balance only slightly at 60 Mc; all other stray capacitances are either incorporated into the bridge arms or, by means of shielding, placed across the generator or detector terminals where they become harmless.

At high radio frequencies the limiting residual impedance has been found to be the residual inductance of variable air capacitors. Thus, in the TYPE 916-A Radio-Frequency Bridge, the residual inductance of the resistance balancing capacitor is the limiting factor on the upper frequency range of the bridge, in so far as the bridge elements themselves are concerned. In the TYPE 821, on the other hand, the residual inductance of the susceptance balancing capacitor is the factor which determines the upper frequency limit at which accurate measurements can be made.

Residual series inductance in bridge arms is ordinarily negligible at audio frequencies, except in measurements of very small inductors. The TYPE 667-A Inductance Bridge uses TYPE 668 Compensated Decade Resistors in order to avoid change in residual inductance as the resistance is varied. At radio frequencies the effect of inductance is much more serious, and variable resistors are not suitable for use above a few megacycles.

SHIELDING AND GROUNDING: The readings of any bridge should be sensibly independent of its surroundings and the position of the operator. To satisfy these conditions, bridges are completely surrounded by a grounded shield, and care is taken to use either grounded or insulated shafts on all controls. It is also common practice to ground the junction of the unknown and standard arms to this shield. Residual capacitances of the bridge

FIGURE 7. In the TYPE 916-A Radio-Frequency Bridge a series-substitution method of measurement is used. In this type of measurement stray capacitance to ground in the unknown arm can be particularly troublesome. Triple shielding is used in this arm to control the stray capacitances, as illustrated in Figure 8.

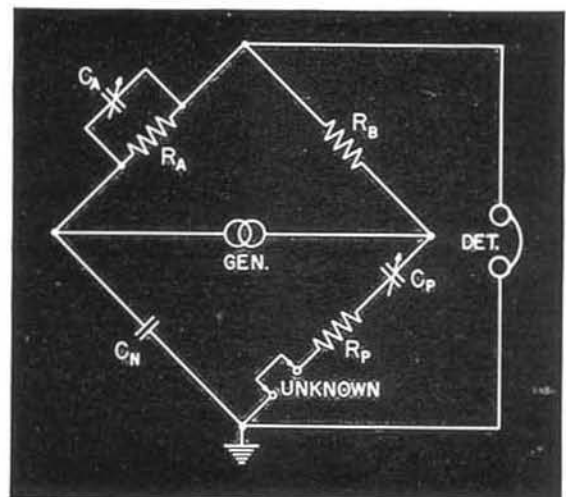

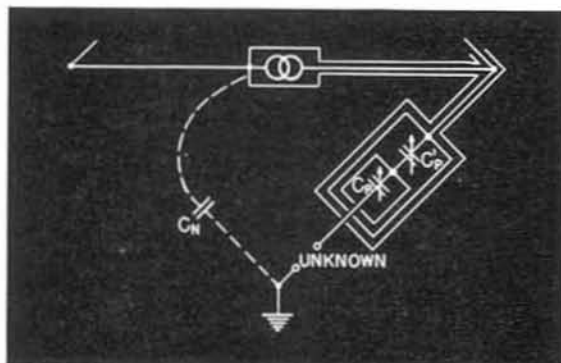
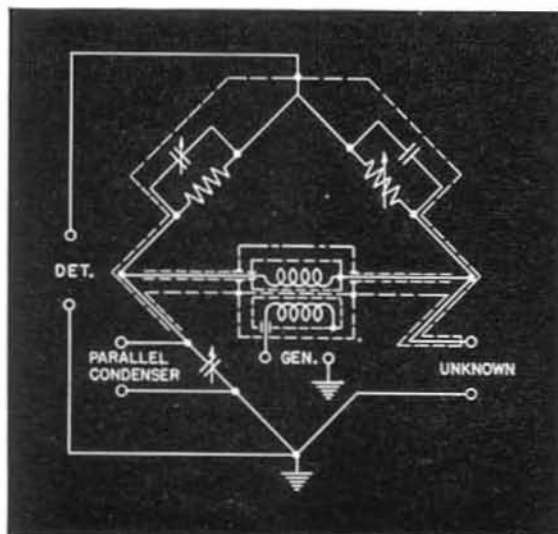

FIGURE 8. Showing the shielding of the unknown arm in the TYPE 916-A Radio-Frequency Bridge. In this assembly the innermost shield localizes the variable stray capacitance of the rotor of C_2 and prevents it from falling across C_3 , where it would cause interlocking of the settings of the two capacitors. The middle shield throws the stray capacitances of the two capacitors to the right-hand corner of the bridge, while the outermost shield places the capacitance of the right-hand corner across the generator, where it is harmless.

This puts the capacitance from the outer shield to ground across the N arm of the bridge. Actually, the physical arrangement of the bridge is such that this capacitance constitutes the bridge arm, with only a trimmer capacitor connected across it to correct for small variations between instruments.

arms to the shield are placed across the two arms thus grounded. Although a relatively large error may be introduced by these capacitances, it can often be eliminated by an initial zero reading or by making the residual capacitance part of the capacitance standard. A bridge with one unknown terminal grounded in this manner will measure the "total impedance" of the unknown, which includes its terminal impedance to ground. The TYPES 716, 1611, 916, and 667 are of this type, placing one terminal of the unknown at ground potential. If, on the other hand,



neither of the unknown terminals is grounded, the bridge will measure the direct impedance across these terminals, provided that the terminal impedances to ground are large compared to the bridge arms. TYPES 650 and 740-B have neither unknown terminal grounded and hence measure direct impedance. Under certain conditions, however, the TYPE 650 can be adapted for measuring grounded impedances, and the TYPE 1611 for measuring direct impedance. The TYPE 544-B Megohm Bridge can be connected either way and can, therefore, measure either total or direct resistance.

SHIELDED TRANSFORMER: The bridge balance should be independent of the type of generator and detector used. This condition is met by the use of a TYPE 578 Shielded Transformer. One transformer winding is connected between two opposite corners of the bridge, neither of which is grounded. It is immaterial which side of the transformer is connected to generator or detector, except as the sensitivity of the bridge is affected by the transformer ratio. For bridge balances, the small, constant, and known terminal capacitances of the transformer are then substituted for the large, variable, and unknown capacitances of the generator or detector.

DETECTORS: To obtain the maximum precision of balance with any bridge or null-balance circuit it is necessary to obtain a virtually complete null balance. With modern vacuum-tube circuits, however, sufficient sensitivity can be obtained to utilize all the potential precision of any null-balance network.

FIGURE 9. Illustrating the shielding arrangement of the TYPE 716-C Capacitance Bridge. The ratio arms with their compensating capacitor, the dissipation factor capacitor, and the input transformer are all mounted on insulated subpanels and completely shielded. The shield is connected to the junction of the ratio arms, thereby placing its capacitance to ground across the detector terminals.

The shield around each transformer winding is connected to the winding, eliminating the terminal capacitances. A third shield, between the winding shields, is connected to the junction of the ratio arms. The capacitance between the third shield and the secondary winding shield is thus placed across the right-hand ratio arm, and its effect can be eliminated in the initial balance. Similarly, the capacitance between the primary shield and the interwinding shield goes across the detector terminals and does not affect the balance.

No capacitances are placed across the standard and unknown arms other than that of the leads and of the panel binding posts. The small amount placed across the standard capacitor is taken into account in the calibration, while that across the unknown terminals is less than one micromicrofarad.



In some bridge circuits the balance is dependent upon frequency, and the value of the unknown impedance usually varies with frequency. Consequently, the presence of harmonics in the input to the bridge or their production in a non-linear impedance within the bridge may obscure the fundamental balance. A null balance may also be masked by the residual noise level of the oscillator and amplifier used. For these reasons it is usually advisable to employ a selective detector, tuned to the frequency at which it is desired to balance the bridge.

Audio and Sub-Audio Frequencies: At audio frequencies, the conventional detector is a vacuum-tube amplifier such as the TYPE 1231-B Amplifier and Null Detector and a pair of head telephones. Where a visual indication of balance is desired, as is necessary at frequencies below about 300 cycles, a rectifier-type voltmeter or a vacuum-tube voltmeter can be substituted for the head telephones.

The TYPE 1231-B Amplifier and Null Detector has a panel meter which can be used as a self-contained null indicator. This instrument can also be made selective (20 db to the second harmonic) by the addition of the TYPE 1231-P Tuned Circuits.

The TYPE 736-A Wave Analyzer and the TYPE 760-A Sound Analyzer, in conjunction with an amplifier, are also very satisfactory selective bridge detectors. The wave analyzer is particularly useful when extreme selectivity at the higher audio frequencies is required, while the sound analyzer provides exceptionally good selectivity at low audio frequencies. For measurements over a wide range of frequencies, these instruments have the advantage of being continuously variable in frequency.

For some measurements it may be desirable to have separate indications of balance for the resistive and reactive balances, and for this purpose the TYPE 707-A Cathode-Ray Null Detector is recommended.

Radio Frequencies: At radio frequencies, any well-designed commercial radio receiver can be used. Head telephones, a loudspeaker, or a meter can be used as the actual balance indicator. Since tuned radio-frequency devices are inherently selective, the problem of radio-frequency harmonics is not significant. The receiver should preferably have an r-f sensitivity control and provision for disconnecting the a-v-c circuit, in order to facilitate the approach to balance.

SENSITIVITY: The precision to which a bridge can be balanced depends primarily upon the voltage applied to the bridge and the sensitiv-

ity of the detector. It also depends upon the ratio of impedances of the two arms across which the generator is placed and the ratio of the impedance of the detector to the bridge impedance.

If the generator is connected across two similar bridge arms, the ratio of output voltage to input voltage is

$$\frac{E_o}{E_i} = \frac{\frac{A}{B}}{\left(1 + \frac{A}{B}\right)^2} d \quad (2)$$

where A and B are the arms across which the generator is connected, and d is the fractional precision desired in balancing the reactive component, or the minimum value of dissipation factor to be detected.

If the two bridge arms across which the generator is connected are not alike, but one is resistive and one reactive, the equation becomes

$$\frac{E_o}{E_i} = \frac{\frac{A}{B}}{1 + \left(\frac{A}{B}\right)^2} d \quad (3)$$

Both expressions are developed on the assumption that the impedance of the detector is high compared to that of the bridge arms. This condition is met by the use of a vacuum-tube amplifier.

From the above equations and the known input voltage, the output voltage corresponding to a given value of d can be calculated. The ratio of this voltage to the minimum voltage which will actuate the detector is the amplification required.

As an example, consider the TYPE 716 Capacitance Bridge. For equal ratio arms 100 volts can be applied to the bridge from a 0.5 watt generator. To make a capacitance balance to $\pm 0.1\%$ demands the detection of 25 mv. To make a dissipation factor balance to ± 0.00001 requires a sensitivity of 250 μ v. The first voltage is easily within the range of head telephones without an amplifier, while the second is not. A typical bridge amplifier has a gain of 77 db or 7000 when working with head telephones or a rectifier voltmeter such as the TYPE 483-F Output Meter. With the telephones the gain is more than sufficient. With the rectifier meter (minimum deflection = 0.02 volt), the gain is also sufficient, since even for the dissipation factor balance a gain of only 80 is needed. The TYPE 1231-B Amplifier and Null Detector has a built-in vacuum-tube voltmeter which provides essentially the same sensitivity as with TYPE 483-F. Now suppose these same measurements to be made on a 1 μ f capacitor for



BRIDGES

which the ratio arms must be 1000 to 1. Using the full gain of the amplifier, the rectifier meter can only balance for dissipation factor to ± 0.00003 , so that telephones must be used to obtain the required sensitivity.

POWER SOURCE: The main considerations in the selection of a power source for a-c bridge measurements are frequency stability, power output, and harmonic content.

The TYPES 740-B and 1611-A are designed for 60-cycle measurements and operate directly from the a-c power line. The TYPE 650-A has a self-contained 1000-cycle microphone hummer, or the TYPE 650-P1 Amplifier-Oscillator, and no external oscillator is required unless it is desired to make measurements at frequencies other than 1000 cycles. All the other bridges described in this section require some type of external oscillator.

For single-frequency measurements at 1000 cycles, the TYPE 572-B Microphone Hummer, the TYPE 813-A Audio Oscillator, and the TYPE 723 Vacuum-Tube Fork are satisfactory provided the power requirements are low. All these operate from batteries, although the TYPE 723 can also be obtained in a-c operated models. A 400-cycle model of the TYPE 723 is also available.

When a highly precise balance is desired, more power is required than can be furnished by small battery-operated oscillators of the type mentioned above. For measurements at 1000 cycles or at a number of fixed frequencies, the TYPE 1301-A Oscillator is recommended. This oscillator is a-c operated and delivers at least $\frac{1}{2}$ watt with extremely good waveform. When a continuously variable frequency is needed the TYPE 913-C Beat-Frequency Oscillator or the TYPE 1302-A Oscillator is recommended.

For measurements at radio frequencies with the TYPE 916-A Radio-Frequency Bridge, or the TYPE 821-A Twin-T Impedance-Measuring Circuit, a radio-frequency oscillator is required. The TYPE 1001-A and TYPE 805-C Standard-Signal Generators are suitable.

MODULATION: For radio-frequency measurements, it is preferable that the power source

FIGURE 10. Showing how series inductance in the generator and detector leads can cause errors in measurement at radio frequencies.

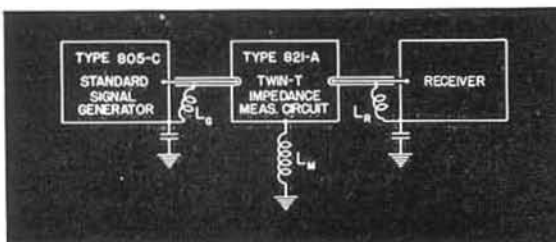

be unmodulated. Distortion in the modulating system, frequency modulation, and asymmetrical side-band cutting in the receiver can produce appreciable errors in the balance point. In addition, maximum sensitivity is obtained with an unmodulated signal and an oscillating detector.

CONNECTIONS: To achieve maximum freedom from electrostatic pickup and body effects, it is desirable to use shielded leads between generator and bridge and between bridge and detector. At audio and low radio frequencies the reactance of the leads and terminals is unimportant, and it is merely necessary to prevent the introduction of extraneous voltages into the detector or the unknown impedance. At frequencies above a few megacycles, not only does the problem of shielding assume greater importance, but also the reactance of the interconnecting leads becomes a potential source of error. This is illustrated by the block diagram of Figure 10.

A small amount of series inductance in the ground side of the generator cable is designated as L_G ; similar inductances in the receiver cable and the common ground lead as L_R and L_M . The voltage drop in L_G produces a flow of current around the loop consisting of the cable sheath, the ground lead, L_M , and the ground capacitance of the oscillator. Similarly, current flows in the right-hand loop that includes L_R .

The voltage applied to the receiver has, therefore, two components, one from the Twin-T, the other from the drop across L_R . When a null point is reached, therefore, the Twin-T is out of balance by an amount necessary to cancel the effect of the extraneous voltage from L_R , that is, to make the vector sum of the Twin-T output voltage and the extraneous voltage equal to zero.

The error in measurement caused by this series inductance is one of the most serious encountered in null measurements at radio frequencies, and, in order to avoid it, coaxial terminals should be used on both generator and receiver.

The TYPES 916-A and 821-A are equipped with coaxial terminals, and coaxial leads are supplied with these instruments to plug into the oscillator and detector.

CLASSIFICATION: The table on the opposite page briefly summarizes the operating ranges, accuracy, and other pertinent data regarding the bridges listed in this section. From this table the most suitable instrument for any given measurement can be determined at a glance, while detailed specifications for each bridge are given on the following pages.

| Type No. | Measures | Range of Measurement | Accuracy* | Frequency | Circuit | Method | Power Source | Detector |
|----------|----------|---|---------------------------|----------------------------|-------------------|-----------------------|---------------------|--------------------|
| 650-A | R | .001 Ω to 1 M Ω | $\pm 1\%$ | dc | Wheatstone | Direct | Int. Batteries | Int. Galvanometer |
| | L | 1 μ h to 100 h | $\pm 2\%$ | 1 kc | Maxwell and Hay | Direct | Internal Oscillator | Head Telephones |
| | C | 1 μ mf to 100 μ f | $\pm 1\%$ | 1 kc | Series R | Direct | Internal Oscillator | Head Telephones |
| | D | .002 to 1 | $\pm 20\%$ | 1 kc | | Direct | | |
| | Q | .03 to 1000 | $\pm 20\%$ | 1 kc | | Direct | | |
| 716-C | C | 100 μ mf to 1 μ f at 1 kc \S | $\pm 0.2\%$ | 100 c, 1 kc, 10 kc, 100 kc | Schering | Direct | External Oscillator | Amp. and Head Tel. |
| | D | .00002 to .56 | $\pm 2\%$ | 100 c, 1 kc, 10 kc, 100 kc | | Direct | | or Output Meter |
| | C | 0.1 μ mf to 1000 μ mf | $\pm 0.2\%$ | 100 c, 1 kc, 10 kc, 100 kc | Schering | Parallel Substitution | External Oscillator | Amp. and Head Tel. |
| | D | Depends on Cx | $\pm 2\%$ | 100 c, 1 kc, 10 kc, 100 kc | | Parallel Substitution | | or Output Meter |
| 916-A | X | -5000 Ω to +5000 Ω \ddagger | $\pm 2\%$ | 400 kc to 60 Mc | Modified Schering | Series Substitution | External Oscillator | Radio Receiver |
| | R | 0 to 1000 Ω | $\pm 1\%$ | 400 kc to 60 Mc | | Series Substitution | | |
| 821-A | C | 0 to 1000 μ mf | $\pm 0.2\%$ | 460 kc to 40 Mc | Parallel-T | Parallel Substitution | External Oscillator | Radio Receiver |
| | B | -6000 to +6000 μ mho \ddagger | $\pm 2\%$ | 460 kc to 40 Mc | | Parallel Substitution | | |
| | G | 0 to 100 μ mho \ddagger | $\pm 2\%$ | 460 kc to 40 Mc | | Parallel Substitution | | |
| 667-A | L | 0.1 μ h to 1 h | $\pm 0.2\%$ | 1 kc | Series R | Direct | External Oscillator | Amp. and Head Tel. |
| 740-B | C | 5 μ mf to 1100 μ f | $\pm 1\%$ | 60 cycles | Series R | Direct | A-C Line | Self-Contained |
| | D | 0 to 50% | $\pm 1.5\%$ of full scale | 60 cycles | | Direct | | Electron-Ray Tube |
| 1611-A | C | 0 to 1100 μ f | $\pm 1\%$ | 60 cycles | Series R | Direct | A-C Line | Self-Contained |
| | D | 0 to 30% | $\pm 2\%$ | 60 cycles | | Direct | | Electron-Ray Tube |
| 544-B | R | 100 k Ω to 10,000 M Ω | $\pm 5\%$ | dc | Wheatstone | Direct | A-C Line | Int. Galvanometer |
| 561-D | μ | .001 to 10,000 | | 1 kc | | Direct | External Oscillator | Amp. and Head Tel. |
| | r_p | 50 Ω to 20 M Ω | | | | Direct | | |
| | S_m | .02 to 20,000 μ mho | | | | Direct | | |
| 1614-A | C | 10 μ mf to 100 μ f | $\pm 2\%$ | 1 kc | Series R | Direct | Int. Oscillator | Head Tel. |
| | D | 0 to 45% | $\pm 10\%$ | 1 kc | | Direct | | |
| 1631-A | L | 10 μ h to 100 h | $\pm 2.5\%$ | 1 kc | Maxwell | Direct | Int. Oscillator | Head Tel. |
| | Q | 1 to 45 | $\pm 10\%$ | 1 kc | | Direct | | |

*Approximate. For detailed accuracy statement, see specifications for each bridge.

\ddagger At 1 Mc; Range varies inversely as the frequency.

\S 100 μ mf to 1000 μ mf at other frequencies.

\dagger At 1 Mc; Range varies directly as the frequency.



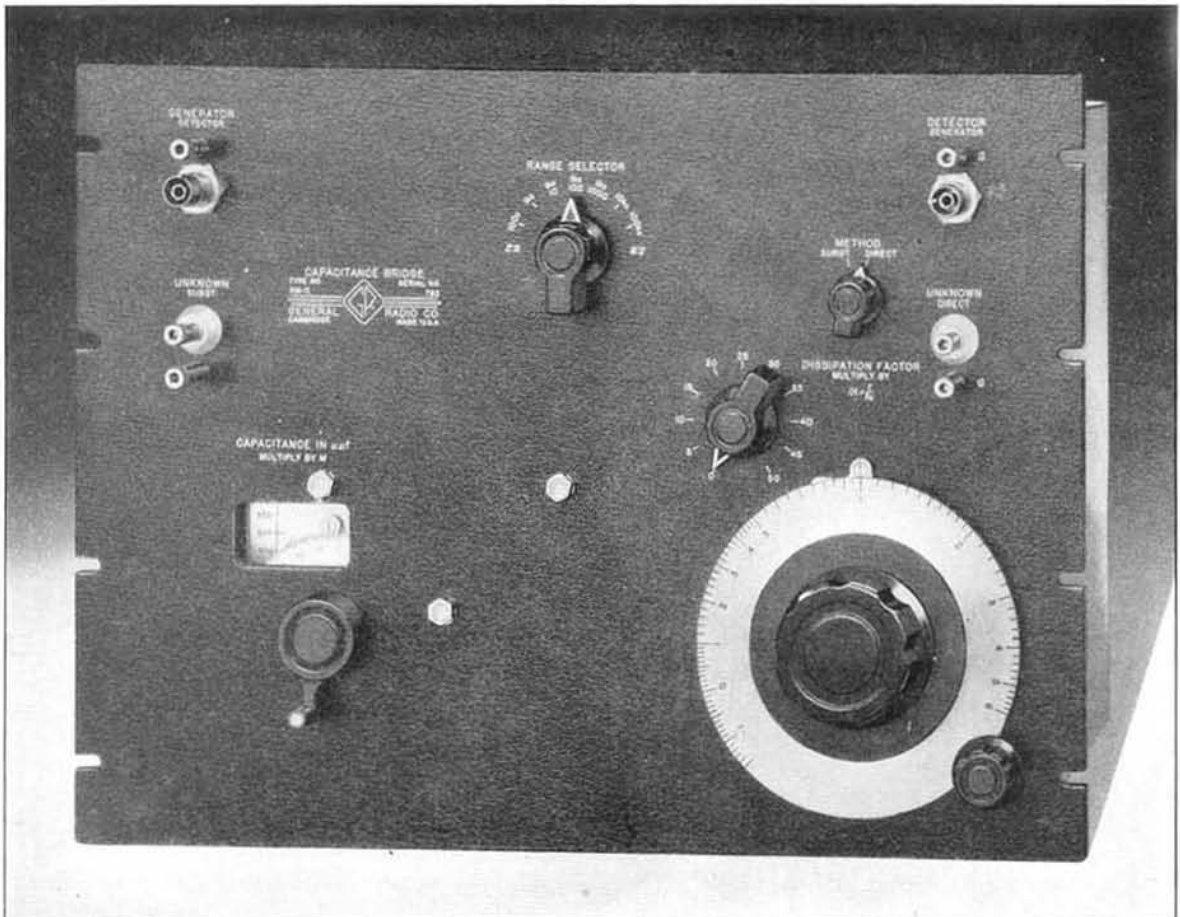

TYPE 716-C CAPACITANCE BRIDGE

USES: This direct-reading capacitance bridge can be used for a wide variety of capacitance and dissipation-factor measurements. Within its scope are the determination of dielectric constant, loss factor, dissipation factor, phase angle, and other dielectric properties of insulating materials, as well as their change with such factors as frequency, temperature, and humidity.

In the General Radio laboratories the TYPE 716 Capacitance Bridge is used for all capacitance standardization measurements. In production it is used for the testing and adjustment of TYPE 505 Capacitors and TYPE 380 Decade-Capacitor Units.

By adding an external decade resistance box, the bridge can be converted to a series- or parallel-resistance bridge. The latter is especially useful in measuring the resistance of electrolytes.

DESCRIPTION: The TYPE 716-C Capacitance Bridge is a modified Schering bridge, direct reading in capacitance and in dissipation factor at 100 cycles, and 1, 10, and 100 kilocycles.

A wide capacitance range at 1 kilocycle is obtained by four ratio arms giving multiplying factors from 1 to 1000 in decade steps. The standard capacitor is a TYPE 722 Precision Condenser, calibrated to read directly in total capacitance. The zero capacitance across the unknown terminals is not greater than $1 \mu\text{f}$. All capacitances to ground of the input transformer and ratio arms are removed from the capacitance arms by placing them in a shielded compartment insulated from the grounded panel and connected to the junction of the ratio arms.

Dissipation factor is read directly from the dial setting of an air capacitor and from a decade step capacitor connected across the fixed ratio arm. The 12-inch scale of the air capacitor is approximately logarithmic, so that, while having a maximum reading of 0.06, its smallest division near zero is 0.0001, thus allowing the estimation of 0.00002. The accuracy of the dissipation factor reading over the wide capacitance range is made possible by adding capacitance across the lower-valued ratio arms, so that the product RC of all the ratio arms is the same.



FEATURES: ▶ Wide capacitance and frequency ranges, high accuracy, and direct-reading dials are three very desirable features found in this bridge.

- ▶ Operation is simple, and both terminals and controls are arranged for convenience and flexibility of operation.
- ▶ The DISSIPATION FACTOR dial is direct

reading for either direct or substitution measurements, because the setting of the METHOD switch determines the ratio arm across which the dissipation-factor capacitor is connected.

- ▶ A new shielded transformer having smaller leakage impedances and lower dielectric losses than those used in earlier instruments makes operation possible up to 300 kilocycles.

SPECIFICATIONS

Ranges: Direct reading—capacitance, 100 μf to 1 μf at 1 ke; 100 μf to 1000 μf at 100 c, 10 ke, and 100 ke; dissipation factor, 0.00002 to 0.56.

Substitution Method—capacitance, 0.1 μf to 1000 μf with internal standard; to 1 μf with external standards; dissipation factor, $0.56 \times \frac{C'}{C_x}$ where C' is the capacitance of the standard capacitor and C_x that of the unknown.

Accuracy: Direct Reading—capacitance, $\pm 2\mu\text{f} \times$ capacitance multiplier reading ($\pm 0.2\%$ of full scale for each range) when the dissipation factor of the unknown is less than 0.01; dissipation factor, ± 0.0005 or $\pm 2\%$ of dial reading, whichever is the larger, for values of D below 0.1.

Substitution Method—capacitance, $\pm 0.2\%$ or $\pm 2 \mu\text{f}$, whichever is the larger; dissipation factor, ± 0.00005 or $\pm 2\%$ for change in dissipation factor observed, when the change is less than 0.06.

A correction chart for the precision capacitor is supplied, giving scale corrections to 0.1 μf at multiples of 100 μf . By using these data substitution measurements can be made to $\pm 0.1\%$ or $\pm 0.5 \mu\text{f}$, whichever is the larger. It is also possible to obtain, at an extra charge, a worm-correction calibration with which substitution measurements can be made to an accuracy of $\pm 0.1\%$ or $\pm 0.2 \mu\text{f}$, whichever is the larger.

When the dissipation factor of the unknown exceeds the limits given above, additional errors occur in both capacitance and dissipation-factor readings. Corrections are supplied, by means of which the accuracy given above can be maintained over all ranges of the bridge.

Ratio Arms: The arm across which the dissipation factor capacitor is normally connected at 1 ke has a resistance of 20,000 ohms. The other arm has four values, 20,000 ohms, 2000 ohms, 200 ohms, 20 ohms, providing the four multiplying factors 1, 10, 100, 1000. Suitable capacitors are placed across these arms so that the product RC is constant. At 100 c, 10 ke, and 100 ke the ratio arms are equal and have resistances of 200,000 ohms, 2000 ohms, and 200 ohms, respectively.

Shielding: Ratio arms, dissipation-factor capacitors, and shielded transformer are enclosed in an insulated shield. The unknown terminals are shielded so that the zero capacitance across them is not greater than 1 μf . A metal dust cover and the aluminum panel form a complete external shield.

Frequency Range: The accuracies given above hold for operating frequencies from 30 c to 300 ke, provided the operating frequency does not differ from the range selector frequency by more than a factor of three. Dissipation-factor readings must be corrected by multiplying the dial reading by the ratio of operating frequency to the range selector frequency.

Voltage: Voltage applied at the GENERATOR terminals is fed to the bridge through a 1-to-1 shielded transformer. A maximum of 1 watt can be applied, allowing a maximum of 300 volts at 1 ke, but only 50 volts at 60 c.

Mounting: The bridge is supplied for mounting on a 19-inch relay rack or for cabinet mounting.

Accessories Required: Oscillator and detector. The TYPE 1302-A Oscillator (page 120) or, for audio frequencies, the TYPE 913-C Beat-Frequency Oscillator or TYPE 1301-A Low-Distortion Oscillator (pages 114 and 118) are satisfactory power sources. TYPE 1231-B Amplifier and Null Detector (page 100) is recommended for use as the detector. For aural null indications, Western Electric 1002-C Telephones can be used with the amplifier. The TYPE 707-A Cathode-Ray Null Detector (page 95) can also be used as a detector for frequencies up to 2 ke.

For substitution measurements, a balancing capacitor is needed. This may be either an air-dielectric model, TYPE 848, or a fixed mica capacitor, TYPE 505.

Accessories Supplied: Two TYPE 274-NE Shielded Connectors.

Dimensions: (Length) 19 x (height) 14 x (depth) 9 inches, over-all.

Net Weight: 42 $\frac{1}{2}$ pounds, relay-rack model; 54 $\frac{1}{2}$ pounds, cabinet model.

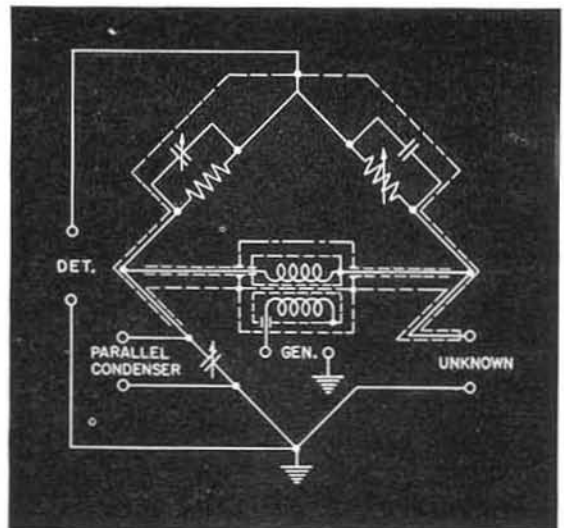

| Type | Code Word | Price |
|---|-----------|----------|
| 716-CR | BONUS | \$450.00 |
| 716-CM | BOSOM | 495.00 |
| Worm-Correction Calibration for Precision Capacitor | WORMY | 50.00 |



TYPE 821-A TWIN-T IMPEDANCE MEASURING CIRCUIT

USES: This instrument is used for impedance measurements at radio frequencies between 0.46 Mc and 40 Mc. It is calibrated in capacitance and conductance and can be used to measure the capacitance and dissipation factor of capacitors, the inductance and *Q* of coils, the resonant impedance of parallel tuned circuits, and the magnitudes and phase angles of high resistances. Through the use of an external fixed capacitor, low resistances, grounded antennas, coaxial transmission lines, and impedance-matching networks can be measured. It is particularly useful for measuring impedances having small phase differences from zero or 90°, such as dielectric samples, low-loss capacitors, high-*Q* coils, and r-f resistors.

DESCRIPTION: The instrument uses a Parallel-T null circuit, as shown in simplified form in the schematic diagram. Measurements are made by a parallel-substitution method. An initial balance of the circuit is obtained with the unknown disconnected; the unknown impedance is then connected and the circuit re-balanced for a null. The components of the unknown impedance are determined from the changes in setting of capacitors *C_B* and *C_G*. The measurement is made in terms of the admittance components of the unknown, susceptance and conductance.

The value of conductance is given by:

$$G_x = \omega^2 C' C'' R \frac{\Delta C_G}{C_G^{(0)}} = k \omega^2 \Delta C_G,$$

and the dial of *C_G* is calibrated to be direct reading at 1, 3, 10, and 30 Mc. For other frequencies, the dial reading is multiplied by the ratio of the squares of the working and direct-reading frequencies. For the initial balance, the conductance dial is set at zero.

The setting of the capacitor *C_B* determines the susceptive balance. The calibrated capacitor dial is direct reading in micromicrofarads. Capacitance can therefore be measured directly. For other types of unknown, it is

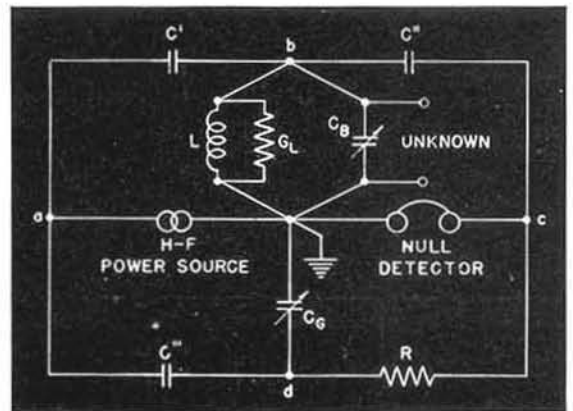

generally more convenient to use the susceptance,

$$B_x = \omega \Delta C_H.$$

Impedance components, reactance and resistance, can, of course, be calculated from the admittance components.

The Twin-T is mounted in a shielded, airplane-luggage type case and is completely portable. TYPE 774 Coaxial Plugs and Jacks are used for the generator and detector terminals. The unknown connects directly to terminals on the panel.

FEATURES: ▶ The accuracy of measurement at high frequencies is achieved by eliminating the effects of some of the residual capacitances which normally limit the performance of bridge circuits.

▶ Highly precise balances are made possible by the type of null method used with the Twin-T.

▶ No transformer is needed because the generator, the detector, the unknown, and the two standard capacitors are brought to a common ground point.

▶ The mechanical arrangement keeps leads short and direct, thus minimizing lead impedances.

SPECIFICATIONS

Frequency Range: 460 kc to 40 Mc.

Capacitance Range: The dial of the standard capacitor is calibrated from 100 to 1100 $\mu\mu\text{f}$, and the range of capacitance measurement by the parallel-substitution method is therefore 0 to 1000 $\mu\mu\text{f}$.

Susceptance Range: -6000 μmho to +6000 μmho at 1 Mc. The range varies directly as the frequency, and at other frequencies the dial reading must be multiplied by the frequency in megacycles.

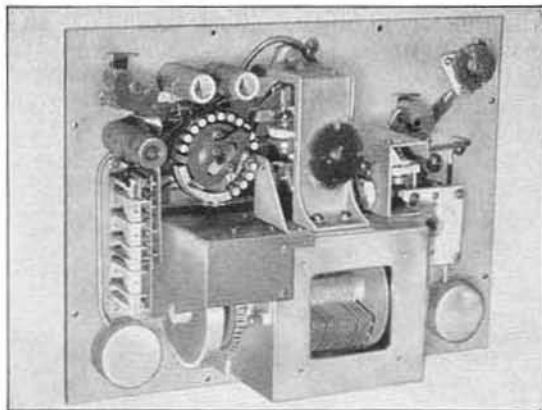

Interior view of the Twin-T, with cover plate removed for adjustments on the standard capacitor.

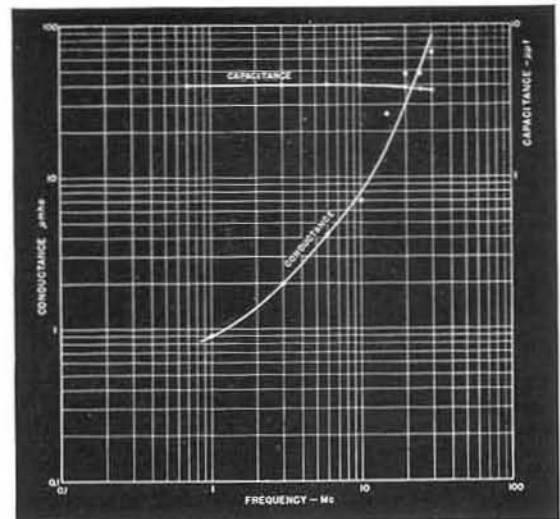

Capacitance and conductance of a TYPE 119-A R-F Choke as measured on the Twin-T.

▶ The circuit elements themselves are designed to have low residual impedances.

▶ Errors inherent in variable resistors at high frequencies are avoided by measuring susceptance in terms of an especially designed variable air capacitor, and conductance in terms of a variable air capacitor and a fixed resistor of the 663 type.

Conductance Range: Direct Reading:

0-100 μmho at 1 Mc 0-1000 μmho at 10 Mc

0-300 μmho at 3 Mc 0-3000 μmho at 30 Mc

Between these direct-reading ranges the range of the conductance dial varies as the square of the frequency.

Accuracy: $\pm(0.1\% + 2\mu\mu\text{f})$ for capacitance. For conductance, $\pm(2\%$ of actual dial reading $+0.1\%$ of full scale). At the higher frequencies, corrections for residual parameters must be applied, and the correction data are included in the instruction book.

A correction chart for the precision capacitor is supplied, giving scale corrections to 0.1 $\mu\mu\text{f}$ at multiples of 100 $\mu\mu\text{f}$. By using these data, capacitance measurements can be made to $\pm 0.1\%$ or $\pm 0.5\mu\mu\text{f}$, whichever is the larger.

Accessories Supplied: Two TYPE 774 coaxial cables for connections to generator and detector.

Accessories Required: A suitable radio-frequency generator and a detector are required. The TYPE 805-C Standard-Signal Generator is a satisfactory generator, as are the older TYPE 605-B and the TYPE 684-A Modulated Oscillator. A well shielded radio receiver covering the desired frequency range is recommended for the detector. The coaxial cable supplied for connection to the receiver is fitted with spade terminals at one end for connecting to the receiver input terminals. For best results, however, it is recommended that the receiver be fitted with a TYPE 774-G Panel Plug and the cable with a TYPE 774-M Cable Jack. These coaxial terminals are described on page 204.

Mounting: The instrument is mounted in a shielded, airplane-luggage type of case with carrying handle.

Dimensions: $17\frac{3}{4} \times 12 \times 9\frac{1}{2}$ inches, over-all.

Net Weight: 29 pounds.

| Type | Code Word | Price |
|-----------------------|-----------|----------|
| 821-A Twin-T | LAGER | \$460.00 |

PATENT NOTICE. See Note 3, page vi.

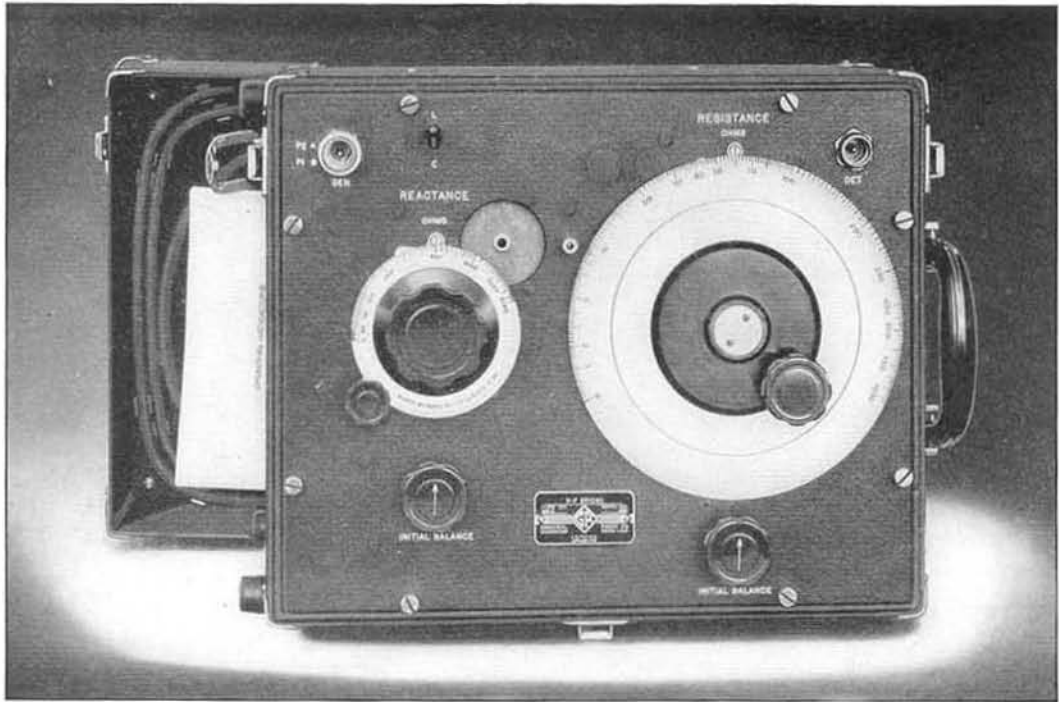

TYPE 916-A RADIO-FREQUENCY BRIDGE

USES: The TYPE 916-A Radio-Frequency Bridge is designed for impedance measurements at frequencies between 400 kc and 60 Mc. It can be used to measure directly the reactance and resistance of antennas, transmission lines, and circuit elements. Through the use of an external parallel capacitor, parallel tuned circuits, high resistances, and other high impedances can be measured.

This instrument is intended for measuring low impedances and complements the TYPE 821-A Twin-T, which is best suited for measuring high impedances.

DESCRIPTION: A new type of bridge circuit is used, which is shown schematically in the diagram below. Measurements are made by a series-substitution method. The components of the unknown impedance are determined from the change in settings of capacitors C_A and C_P . The unknown reactance at 1 Mc is read directly in ohms from the dial of C_P , and the unknown resistance in ohms from the dial of C_A .

Schematic circuit diagram of the Type 916-A Radio-Frequency Bridge.

In making measurements the bridge is first balanced by means of capacitors C_P and C_A with a short-circuit across the unknown terminals. The short is then removed, the unknown impedance connected, and the bridge re-balanced. The resistance is then given by

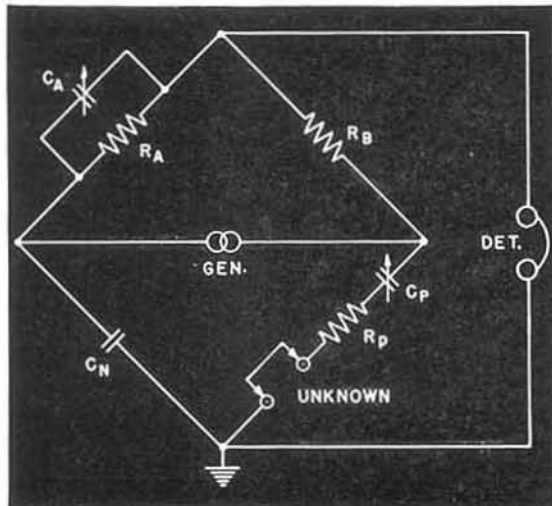

$$R_z = R_B \frac{(C_{A2} - C_{A1})}{C_N}$$

and the reactance by

$$X_z = \frac{1}{\omega} \left(\frac{1}{C_{P2}} - \frac{1}{C_{P1}} \right)$$

where the subscripts 1 and 2 denote the dial readings for the initial and final balances, respectively.

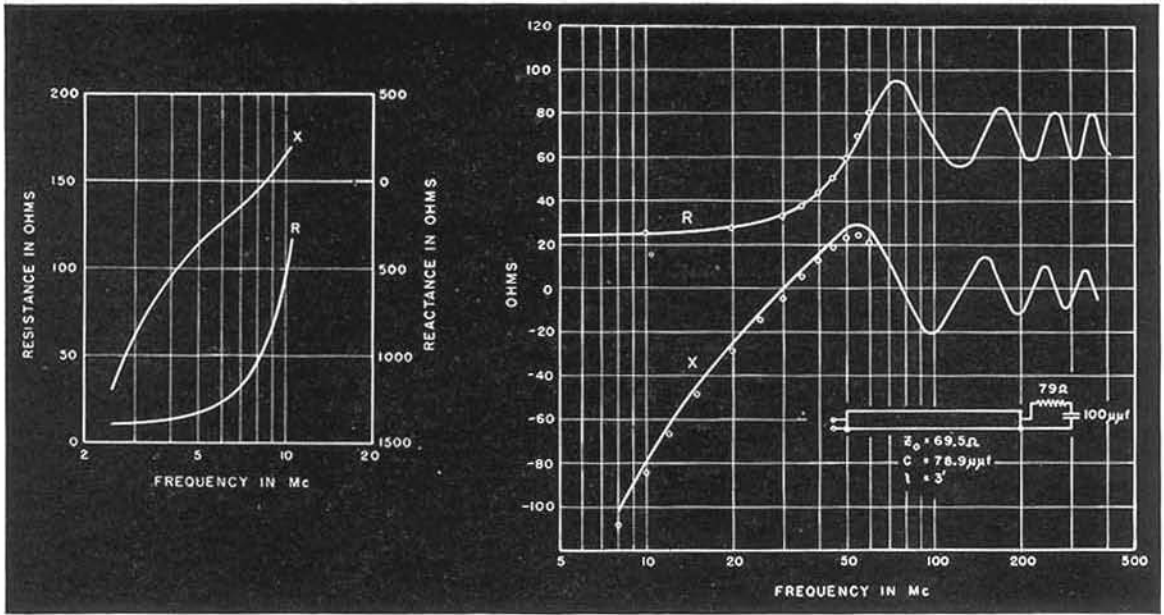

Typical measurements made with the TYPE 916-A Radio-Frequency Bridge. *Left*, reactance and resistance of an antenna system. *Right*, input reactance and resistance of a transmission line. The solid lines show calculated values; the circles, measured values.

- FEATURES:**
- ▶ Resistance is read in ohms, independent of frequency, directly from the scale of an air capacitor. This feature is made possible by the use of a substitution method of measurement in this bridge circuit.
 - ▶ Antenna measurements are particularly easy to make because of the direct-reading resistance feature and also because the dial of C_P is calibrated in ohms reactance at 1 megacycle.
 - ▶ The resistive component is measured in

- terms of a *fixed* resistor (R_B), a fixed capacitor (C_Y), and a variable capacitor (C_A). This feature is an important factor in the high-frequency performance of the bridge because residual parameters can be made much smaller in a fixed resistor and a variable capacitor than in a variable resistor.
- ▶ Convenience and protection in transporting the bridge for field work is provided by using a rugged luggage-type carrying case and cover.

SPECIFICATIONS

Frequency Range: 400 ke to 60 Mc.
Reactance Range: 5000 Ω at 1 Mc. This range varies inversely as the frequency, and at other frequencies the dial reading must be divided by the frequency in megacycles.
Resistance Range: 0 to 1000 Ω.
Accuracy: For reactance, at frequencies up to 50 Mc, $\pm (2\% + 1 \Omega + 0.0008 \times R \times f)$, where R is the measured resistance in ohms and f is the frequency in Mc.
 For resistance, at frequencies up to 50 Mc, $\pm (1\% + 0.1 \Omega)$, subject to correction for residual parameters. At high frequencies the correction depends upon the frequency and upon the magnitude of the unknown resistance component. At low frequencies the correction depends upon the frequency and upon the magnitude of the unknown reactance component. Plots of both these corrections are given in the instruction book that is supplied with the bridge.
 Satisfactory operation can be obtained at frequencies up to 60 Mc with somewhat poorer accuracy above 50 Mc than at lower frequencies.
Accessories Supplied: Two input transformers, one covering the range from 400 ke to 3 Mc, the other from

3 Mc to 60 Mc; two leads of different lengths (for connecting the unknown impedance); two TYPE 774 coaxial cables for connecting generator and detector.
Accessories Required: A radio-frequency generator and a detector are required. The TYPE 805-C Standard-Signal Generator is a satisfactory generator, as are the older TYPE 605-B and the TYPE 684-A Modulated Oscillator. A well-shielded radio receiver covering the desired frequency range is recommended as the detector. The coaxial cable supplied for connection to the receiver is fitted with spade terminals at one end for connection to the receiver input terminals. For best results, however, it is recommended that the receiver be fitted with a TYPE 774-G Panel Plug and the cable with a TYPE 774-M Cable Jack. These coaxial terminals are described on page 204.
Mounting: Airplane-luggage type case with carrying handles. Both input transformers are mounted inside the case. Coaxial cables, leads, and instruction book are stored in the cover of the instrument when not in use.
Dimensions: 17 x 13½ x 11½ inches over-all.
Net Weight: 34¼ pounds.

| Type | Code Word | Price |
|------------------------------|-----------|----------|
| 916-A Radio-Frequency Bridge | CIVIC | \$450.00 |

PATENT NOTICE. See Note 16, page vi.



TYPE 650-A IMPEDANCE BRIDGE

USES: The TYPE 650-A Impedance Bridge will measure the inductance and storage factor, Q , of coils, the capacitance and dissipation factor, D , of capacitors, and the a-c and d-c resistance of all types of resistors.

In the laboratory it is extremely useful for measuring the circuit constants in experimental equipment, testing preliminary samples, and identifying unlabeled parts. In the shop and on the test bench it has many applications in routine testing and fault location. Thousands of these bridges are in use all over the world, in government and industrial laboratories, educational institutions, electric generating stations, and radio broadcasting stations.

DESCRIPTION: TYPE 650-A Impedance Bridge is a conventional 4-arm impedance bridge. It is entirely self-contained, including standards, batteries, and tone source, and is direct reading over wide ranges of d-c resistance, a-c resistance at 1000 cycles, capacitance and dissipation factor $D = \frac{R}{X}$ at 1000 cycles, and inductance and storage factor $Q = \frac{X}{R}$ at 1000 cycles.

Results are read directly from dials having approximately logarithmic scales. The position of the decimal point and the electrical unit in terms of which the measurement is made are indicated by the positions of two selector switches.

Resistance is measured in terms of a standard resistance arm; inductance and capacitance are measured in terms of mica capacitance standards, similar in construction to the TYPE 505 Capacitors.

A built-in galvanometer is used as the detector for d-c work, and head telephones, usually preceded by an amplifier, are used for 1000-cycle measurements.

FEATURES: ▶ Complete availability, because of the self-contained standards and power supply, is an outstanding feature of this

bridge. The only accessory needed is a pair of head telephones.

▶ Wide ranges of all kinds of impedances can be measured simply and with rapidity.

▶ Convenience combined with sufficient accuracy for all but very precise work make the TYPE 650-A invaluable in every electrical laboratory.

▶ Direct-reading dials eliminate additional time and trouble with calculations. The panel photograph shows the simplicity of the controls.

SPECIFICATIONS

Range: The ranges of the instrument are given in the following table. The numerical values are the readings of the calibrated dials multiplied by the settings of the decade selector switches.

| | Minimum | Maximum |
|---|-------------------|-----------------|
| Resistance | 1 milliohm | 1 megohm |
| Capacitance | 1 micromicrofarad | 100 microfarads |
| Inductance | 1 microhenry | 100 henrys |
| Dissipation Factor $\left(\frac{R}{X}\right)$ | .002 | 1 |
| Storage Factor $\left(\frac{X}{R} \text{ or } Q\right)$ | .02 | 1000 |

Accuracy: The large direct-reading dial covers two decades, the main decade being spread out over 12 inches (three-quarters of the dial). It may be set to 0.2%.

Accuracy of readings for capacitance and d-c resistance is 1% for the intermediate multiplier decades; for inductance, 2%. The accuracy falls off in the lower ranges because of the extremely small values to be measured. The error increases to 2% for very large values of capacitance and d-c resistance, and to 10% for large values of inductance.

Accuracy of reading for dissipation factor or for storage factor in terms of its reciprocal is either 20% or 0.005, whichever is the larger. For dissipation factors larger than 0.05 and for corresponding storage factors, the accuracy is 10%. For capacitances of less than 500 μmf when measured on the lowest capacitance multiplier the error in dissipation factor increases as capacitance decreases, reaching about 100% for 100 μmf.

The frequency of the microphone hummer is 1000 cycles within ±5%.

Power Supply: Four No. 6 dry cells for the d-c measurements and for driving the microphone hummer are supplied and space for them is provided at the top of the cabinet.

The TYPE 650-P1 Oscillator-Amplifier described on the next page is also designed to fit into the battery compartment and provide increased a-c and d-c output for the bridge. In addition it has an amplifier for use in the detector circuit and a number of other operating features.

External Generator: Provision has been made for using an external generator, although its capacitance to ground may introduce some error. Subject to this limitation, the frequency may be varied over a wide range from a few cycles to 10 kc. The effect of generator ground capacitance can be reduced by using a TYPE 578 Transformer between generator and bridge. (See page 80.) The reading of the main dial is independent of frequency, while the reading of the storage factor dial must be multiplied by, and that of the dissipation factor dial divided by, the generator frequency in kilocycles to give the correct values. Provision is made for adding external resistance if it is necessary to increase the ranges of these dials.

Accessories Required: Head telephones; Western Electric No. 1002-C are recommended. To increase the sensitivity, an amplifier is recommended. (See TYPE 650-P1 Oscillator-Amplifier, next page.)

Mounting: Black crackle-finish aluminum panel mounted in a shielded walnut cabinet.

Dimensions: (Width) 12 x (depth) 20 x (height) 8½ inches, over-all.

Net Weight: 31¼ pounds including batteries.

| Type | Code Word | Price |
|--------------------------------|-----------|-----------|
| 650-A Impedance Bridge | BEAST | \$240.00* |

*Without telephones, but including batteries.

Schematic diagrams of the circuits used in TYPE 650-A Impedance Bridge.

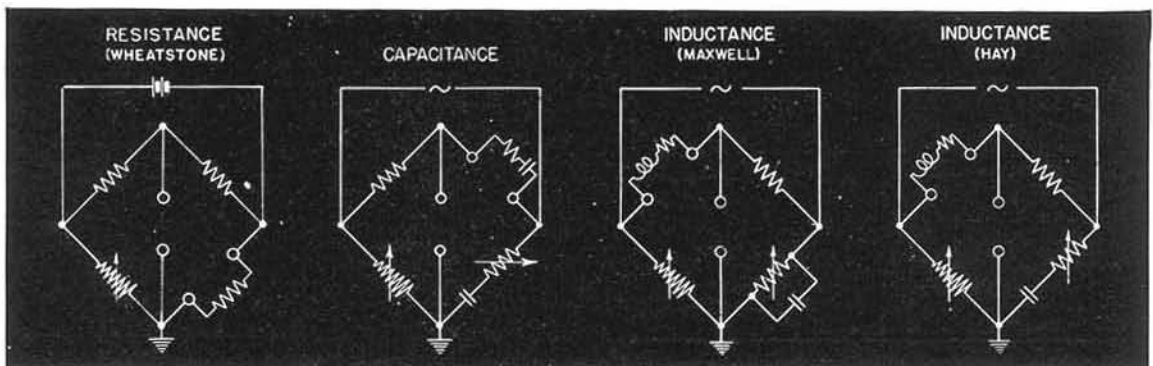

TYPE 650-P1 OSCILLATOR-AMPLIFIER

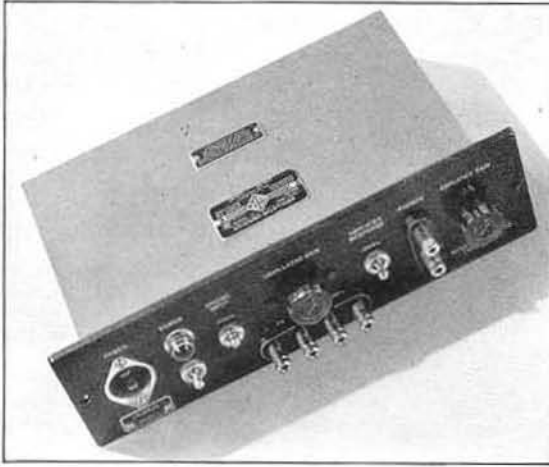

USES: The TYPE 650-P1 Oscillator-Amplifier is a useful combination unit designed to fit into the TYPE 650-A cabinet in the compartment formerly housing the batteries. The TYPE 650-P1 operates from the a-c power line and provides a vacuum-tube oscillator operating at one kilocycle, a source of dc for resistance measurements, and an amplifier to be used with headphones or an a-c galvanometer as the bridge detector.

The TYPE 650-P1 is not limited to operation with the TYPE 650-A Bridge and can be used as a compact oscillator-amplifier combination with other bridge systems.

DESCRIPTION: The vacuum-tube oscillator, amplifier, and rectifier for providing the dc are all mounted in a compact metal cabinet with a top control panel which replaces the wooden cover normally used on the battery

compartment of the TYPE 650-A. The control panel has a switch for selecting either the d-c or the one-kilocycle output, and a switch to select a flat amplifier characteristic or a response tuned to one kilocycle. Both the oscillator output and the amplifier gain can be varied by panel controls.

FEATURES: ▶ A-C operation of TYPE 650-P1 completely dispenses with need for batteries for all laboratory measurements on TYPE 650-A Bridge.

▶ D-C output is considerably higher than the 6 volts normally provided from batteries. Thus, when the self-contained galvanometer is used, the sensitivity of the bridge for higher resistance values is greatly increased.

▶ Oscillator frequency is within 1% of nominal frequency after warm-up periods, thus minimizing errors in *D* and *Q* measurements caused by dependence of dial calibrations on frequency.

▶ Output of oscillator is greater and distinctly purer than the output of the bridge hummer which it replaces.

▶ Oscillator output is adjustable. This feature is especially valuable when measuring iron-cored inductors at low flux densities approaching initial permeability.

▶ Shielded transformer between oscillator and bridge reduces stray capacitance errors normally encountered with external oscillators to values comparable with those from internal hummer.

▶ TYPE 650-P1 can be used separately as oscillator and amplifier or source of dc for other applications.

SPECIFICATIONS

Oscillator:

Frequency — 1 kc \pm 1%.
 Harmonics — less than 2% at full output.
 Open-circuit Voltage — continuously adjustable up to maximum of 12 to 15 volts.
 Internal Impedance — 2000 ohms.
 Hum Level — 15 mv.

Amplifier:

Voltage Gain — continuously adjustable up to about 45 db (with average headphones).
 Selectivity — approximately 15 db attenuation to second harmonic when tuned to 1 kc.
 Hum Level — inaudible.

D-C Output:

Open-circuit Voltage — 190 volts, approximately.
 Internal Resistance — 23,000 ohms.
 Maximum Current — 8 ma, no adjustment provided.
 Can be short-circuited without damage.

Hum Level — less than 100 mv no load.

Power Supply: 105 to 125 (or 210 to 250) volts, 50 to 60 cycles.

Power Input: 10 watts.

Vacuum Tubes: (all supplied).

1 — 6H6 2 — 6SL7-GT

Accessories Supplied: Connector for use between oscillator-amplifier and bridge, and line cord.

Accessories Recommended: Headphones or a-c output meter (such as TYPE 483-F) for use with amplifier on a-c measurements.

Dimensions: Cabinet — 10½ x 2½ x 6¾ inches.
 Panel — 12 x 3¾ inches.

Net Weight: 9 pounds.

| Type | Code Word | Price |
|-------------------------------------|-----------|----------|
| 650-P1 Oscillator-Amplifier | BOGUS | \$150.00 |

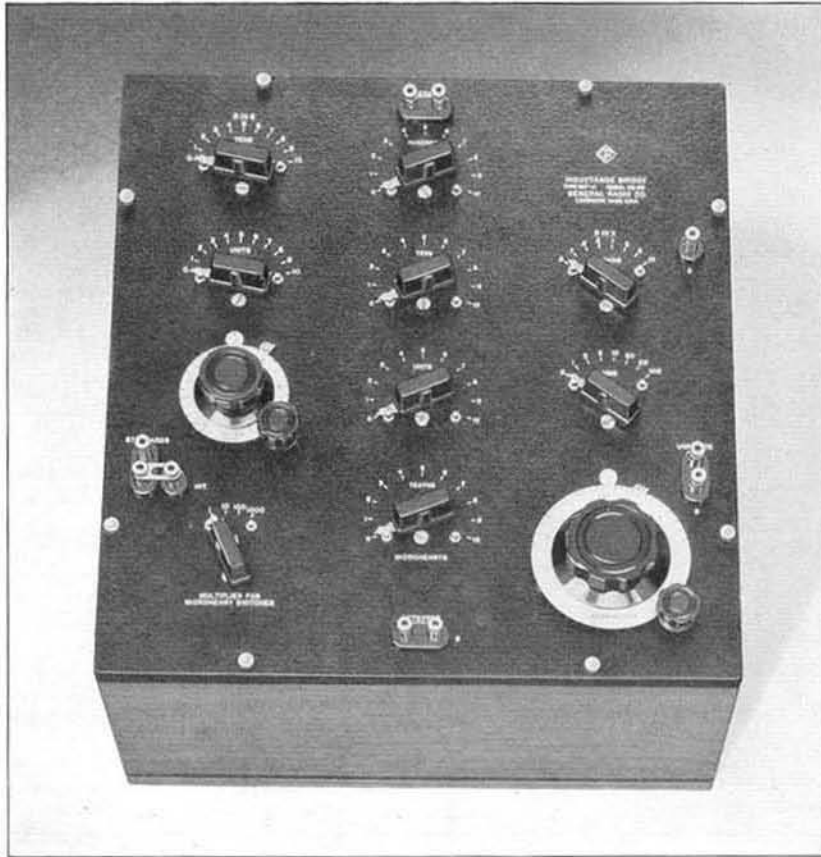

TYPE 667-A INDUCTANCE BRIDGE

USES: This bridge is designed for accurately measuring the audio-frequency inductance of small coils, which have a low value of storage factor, Q , at audio-frequencies. It is used by many coil and receiver manufacturers for all audio-frequency measurements on the tuning coils for radio receivers. It is also capable of measuring higher values of inductance (up to 1 henry) and hence can be used as a general-purpose inductance bridge. When connected as a Campbell mutual inductance bridge, it can be used to measure mutual inductance in terms of the internal standard. Terminals are provided so that the bridge can be connected as a resonance bridge for such measurements as the ratio of a-c to d-c resistance. The d-c resistance can be determined by using a battery and galvanometer in place of the usual a-c generator and detector.

DESCRIPTION: The schematic diagram of the Type 667-A Inductance Bridge shown on the next page indicates that it differs little from the usual inductance bridge. Certain design features, however, have been introduced to eliminate residual sources of error and to make the bridge direct reading. The variable

resistors in both the standard and the unknown arms are inductance compensated, identical in construction with Type 668 Compensated Decade-Resistance Units.

The variable inductor, L_p , in series with the unknown makes it possible to obtain a final inductance balance independent of the resistive balance of the bridge. The standard inductor is wound on a ceramic toroidal form in order to minimize magnetic coupling with the variable inductor. The switch, K , is used when the bridge is connected as a resonance bridge.

FEATURES: ▶ High accuracy (within $0.1 \mu\text{h}$) for the measurement of small inductances is one of the outstanding features of this bridge. ▶ Errors introduced by a sliding-zero balance and the variation of inductance with setting of the decade resistors have been eliminated. Thus, inductances of a few microhenrys can be measured easily and accurately. ▶ An internal standard is provided for convenience, but terminals are available for external standards when necessary to extend the range of the bridge.

BRIDGES

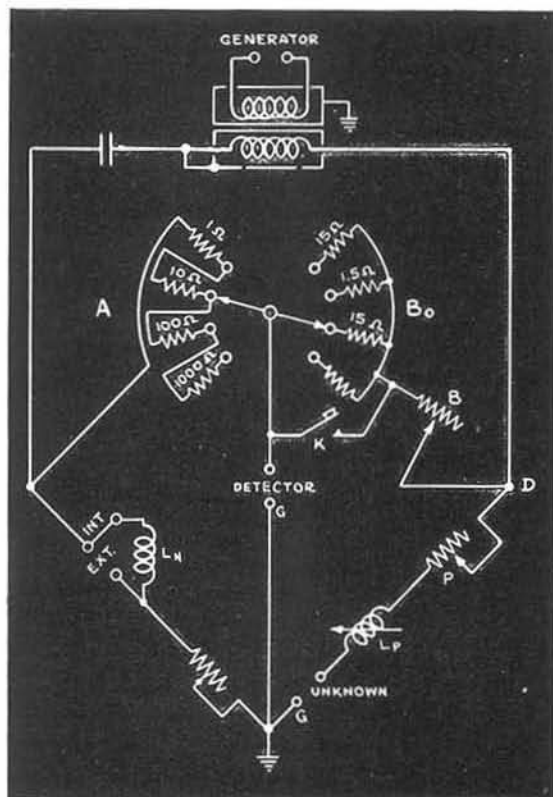

SPECIFICATIONS

Range: Inductance, 0.1 microhenry to 1 henry. The range can be extended by using TYPE 106 Standard Inductors as external standards. When the internal standard is used, the bridge will balance for storage factors between 0.06 and infinity at 1 ke.

Accuracy: Inductance, $\pm(0.2\% + 0.1 \mu\text{h})$. The capacitance across the UNKNOWN terminals is about $90 \mu\text{f}$. This capacitance will increase the value of large inductors fractionally by the amount $\omega^2 LC$. At 1 ke and 1 h the increase is 0.36%.

Frequency Range: All calibration adjustments are made at a frequency of 1 ke. The bridge can be used at any frequency between 60 cycles and 10 kilocycles, but errors resulting from stray capacitance increase with frequency. When large values of inductance are measured with external standards, the frequency should be lowered to avoid resonance effects.

Standards: The standard inductor is a 1-millihenry toroid wound on a ceramic form. Resistance balance of the bridge is made by means of an inductance-compensated resistor.

Mounting: The bridge is supplied mounted in a cabinet.

Accessories Required: Oscillator, amplifier, and head telephones. TYPE 1301-A Oscillator (see page 118) and TYPE 1231-B Amplifier and Null Detector (see page 100) are recommended.

Accessories Supplied: Two TYPE 274-NC Shielded Connectors.

Dimensions: (Length) $17\frac{1}{2}$ x (width) 16 x (height) $9\frac{1}{2}$ inches, over-all.

Net Weight: 33 pounds.

Type

Code Word

Price

667-A

Inductance Bridge

AERIE

\$400.00

TYPE 578 SHIELDED TRANSFORMER

USES: These transformers have been designed for use in direct-reading a-c bridges to isolate the bridge from changes of electrostatic potential in the external circuit and to reduce the effect of the capacitance of this external circuit to ground. Obviously, the transformer can be used to isolate the bridge from either generator or detector. They are also useful in other applications to isolate measuring circuits from the generator and to produce a balanced output from a grounded generator.

DESCRIPTION: The TYPE 578 Shielded Transformer is provided with two shields, one around each winding. A third shield effectively grounds the core laminations. The accompanying diagram shows the arrangement of shields and the capacitances between elements.

FEATURES: ▶ The intershield capacitance is only $30 \mu\text{f}$ so the total added capacitance placed across the bridge arms is only $80 \mu\text{f}$ in place of the usually large and unknown generator-to-ground capacitance which exists when no transformer is used.

▶ Wide ranges of frequency and load impedance are covered by each model.

▶ All models can be used to step up or step

down from generator to bridge and two of the transformers can be connected directly to the 60-cycle line.



SPECIFICATIONS

Turns Ratio: All models have a turns ratio of 4 to 1 and may be used equally well in either direction. The actual number of turns for each winding is given in the table below.

Frequency and Impedance Range: See table below.

Capacitance: The direct capacitance between primary and secondary windings is less than $0.3 \mu\mu\text{f}$; that between the primary and secondary shields is less than $30 \mu\mu\text{f}$. Average values for the capacitances in the diagram are:

- C_1, C_2, C_3, C_4 each $200 \mu\mu\text{f}$
- C_5 $0.3 \mu\mu\text{f}$
- C_7, C_8 each $70 \mu\mu\text{f}$
- C_6 $30 \mu\mu\text{f}$

Winding Inductance: The approximate inductance of any winding is equal to the square of the number of turns multiplied by 3.5×10^{-6} henrys.

Winding Resistance: The d-c resistance of any winding (in ohms) is approximately 30 times the inductance in henrys.

Applied Voltage: The high-impedance winding of Types 578-A or -B may be connected directly across a 115-volt 50 to 60-cycle line if the impedance connected to the other winding equals or exceeds the lowest value given under "primary impedance" in the table below. The Type 578-B may be used at 25 cycles under the same conditions.

For Types 578-A or -B, the low-impedance winding may be connected directly to a 115-volt, 50 to 60-cycle line provided that the resistance across the high-impedance winding exceeds 10,000 ohms. The Type 578-B may be used at 25 cycles under the same conditions.

Insulation: The insulation from winding to winding and from windings to case will withstand 1000 volts, peak.

Mounting and Dimensions: These transformers are mounted in Model B cases (see page 140 for dimensions).

Net Weight: $2\frac{1}{2}$ pounds.

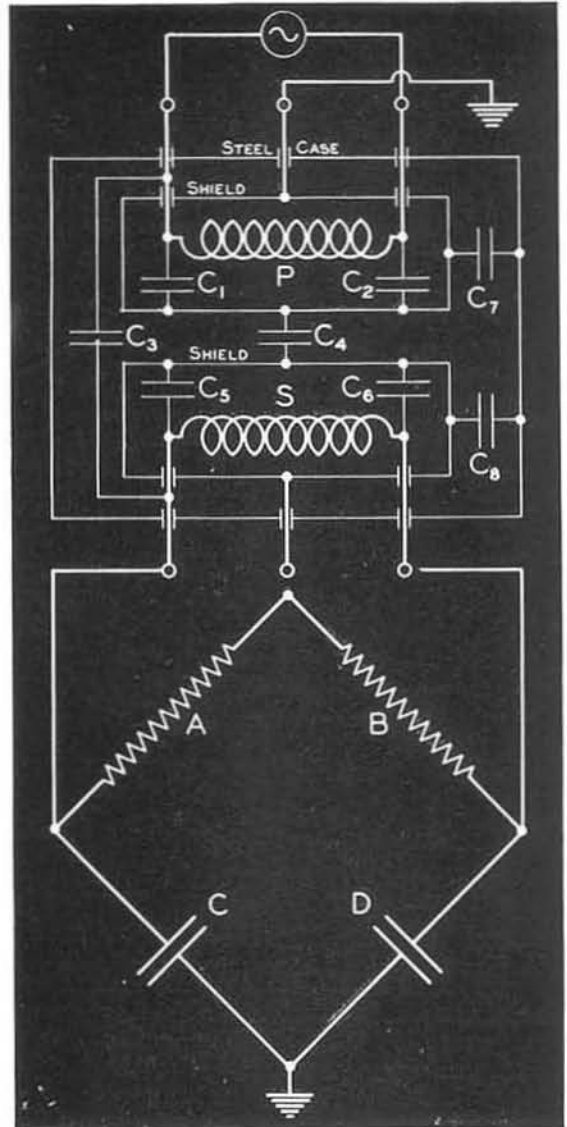

(Above) This diagram shows a grounded bridge supplied through a double-shielded transformer. When the case is grounded, the capacitance placed across each capacitance arm is $40 \mu\mu\text{f}$. This value is known and is considerably smaller than the unknown generator-to-ground capacitance which usually exists when a transformer is not used.

(Left) This shows the winding used in Type 578 Shielded Transformer. The capacitance between shields is kept at a low value by spacing the windings as shown.

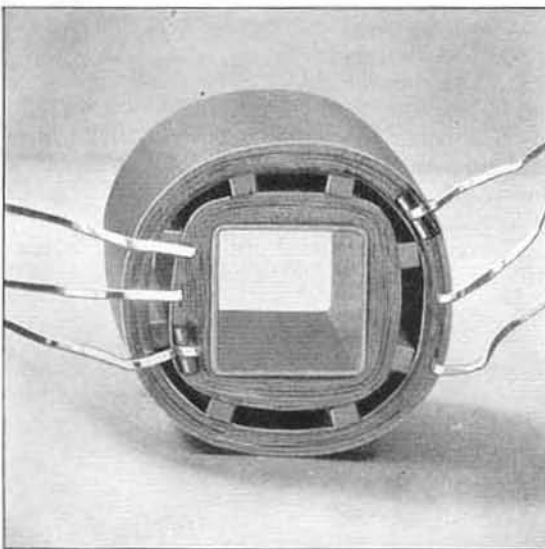

| Type | Turns | Frequency Range* | Impedance Range* | | Code Word | Price |
|-------|--------------|--------------------|-----------------------------|----------------------------------|-----------|---------|
| | | | Primary | Secondary | | |
| 578-A | 600 to 2400 | 50 cycles to 10 ke | 50 Ω to 5 k Ω | 1 k Ω to 100 k Ω | TABLE | \$20.00 |
| 578-B | 1000 to 4000 | 20 cycles to 5 ke | 60 Ω to 6 k Ω | 1.2 k Ω to 120 k Ω | TENOR | 20.00 |
| 578-C | 60 to 240 | 2 ke to 500 ke | 20 Ω to 2 k Ω | 0.4 k Ω to 40 k Ω | TEPID | 20.00 |

*These ranges are for transmission within 6 db. At extremes of both impedance and frequency ranges, the transmission may be down by 12 db.

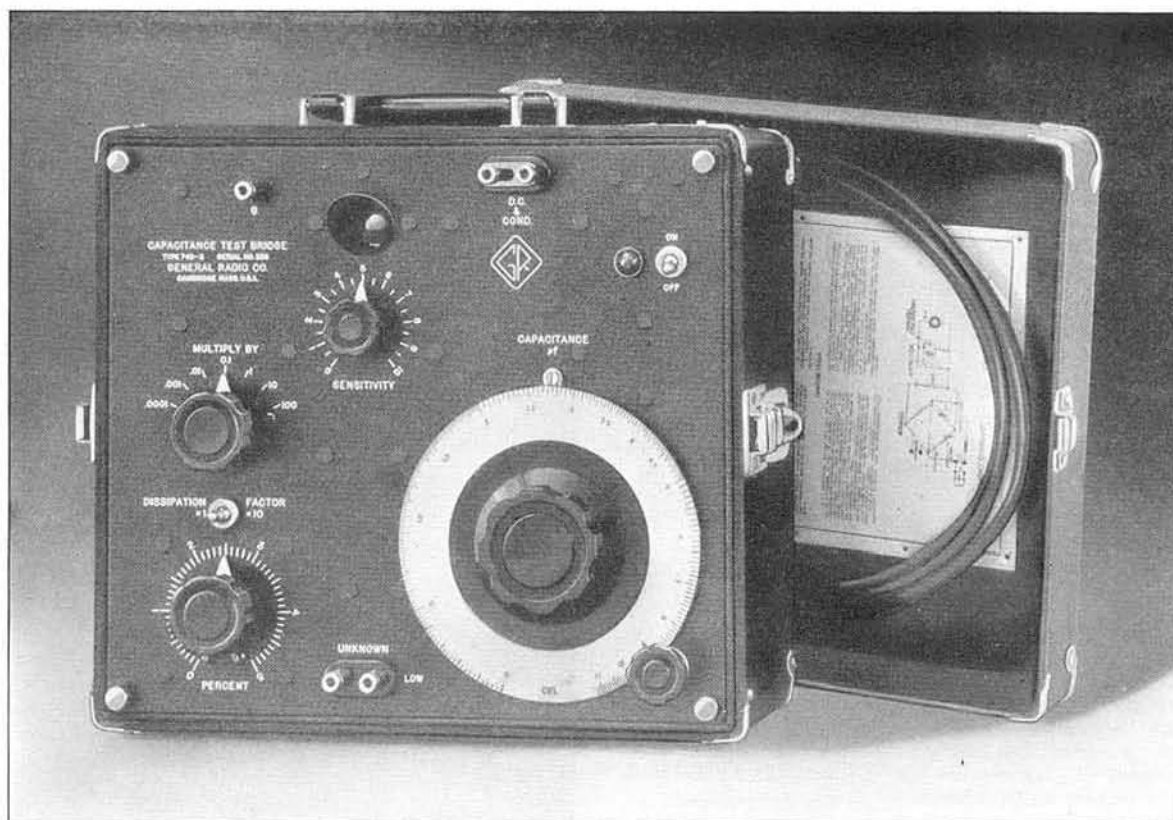

TYPE 740-B CAPACITANCE TEST BRIDGE

USES: The TYPE 740-B Capacitance Test Bridge is a 60-cycle capacitance and dissipation factor bridge for use in both laboratory and production testing of paper, mica, and electrolytic capacitors. The capacitor manufacturer can use it for production tests, the capacitor user for acceptance tests. It is particularly useful in testing electrolytic capacitors because the test conditions approximate the normal operating conditions of use.

DESCRIPTION: The circuit used in this instrument is that of a series-resistance capacitance bridge. It is similar to the capacitance portion of the TYPE 650-A Impedance Bridge, but adapted for 60-cycle use. One ratio arm is variable in decade steps, and the other is continuously variable and calibrated directly in capacitance.

Dissipation factor is measured by means of a dual-range variable resistor in series with the standard capacitor. The dial is direct reading in dissipation factor ($R\omega C$). Because the switching capacitances of the TYPE 650-A Impedance Bridge are eliminated in this instrument, a considerably higher accuracy of dissipation-factor measurement is obtained.

Provision is made for introducing a d-c

polarizing voltage in series with the capacitor under test.

A visual null indicator is used, consisting of tuned amplifier and an electron-ray tube (the so-called magic eye). A sensitivity control is provided. With this type of null indicator, it is possible to use the bridge as a limit bridge in production testing.

Power is obtained from the 60-cycle line through a shielded isolating transformer.

The complete bridge assembly is mounted in an airplane-luggage type of carrying case. Operating instructions are conveniently mounted in the cover of the instrument, and a complete circuit diagram is attached to the base of the cabinet.

FEATURES: ▶ The direct capacitance of ungrounded capacitors is measured by this bridge.

▶ Power-line operation and the visual indicator make the instrument desirable for production testing, especially in noisy locations where headphones would be useless.

▶ The ranges of measurement are wide and the operation is simple.

▶ A minimum of capacitance between generator terminals and ground is insured by

careful shielding in the power-supply transformer.

► An accuracy of 1% for capacitance, and 1.5% of full scale for dissipation factor, has been obtained over most of the range of the instrument.

► Normal operating conditions can be reproduced when testing electrolytic capacitors by using a d-c polarizing voltage. The a-c voltage impressed by the bridge itself is small and simulates the ripple usually encountered in power-supply filters.

► Adequate protection is afforded by the covered case, and small size and light weight make it possible to move the instrument easily and set it up wherever necessary.



Production testing of electrolytic capacitors with the capacitance test bridge.

SPECIFICATIONS

Capacitance Range: 5 μf to 1100 μf in seven ranges. Capacitance values are read directly from a logarithmic dial and multiplier switch.

Capacitance Accuracy: Within $\pm 1\%$ over the main decade (1 to 11) of the CAPACITANCE dial for all multiplier settings except .0001. Within $\pm 1.5\%$ or $\pm 3 \mu\text{f}$, whichever is the larger, on the .0001 multiplier on the main decade of the CAPACITANCE dial. Below 100 μf the error gradually increases to $\pm 5 \mu\text{f}$ as zero is approached.

Dissipation Factor Range: 0 to 50% in two ranges. Dissipation factor values are read directly from an engraved scale and multiplier switch.

Dissipation Factor Accuracy: Within $\pm 1.5\%$ of full-scale reading for all capacitance multipliers except .0001.

On the .0001 capacitance multiplier a correction of 0.3% should be subtracted from the dial reading. When this correction is made the calibration is within ± 2 divisions on the x1 multiplier and within ± 1 division on the x10 multiplier (see photograph).

Temperature and Humidity Effects: For measurements above 100 μf the accuracy of measurement is completely independent of temperature and humidity conditions over the range 65° Fahrenheit to 95° Fahrenheit,

0 to 95% relative humidity. For very small capacitances the reading of the dissipation factor dial will be affected by severe humidity conditions.

Voltage Applied to Unknown: The voltage impressed across the unknown terminals varies continuously with the bridge setting. For very small capacitances in the lowest range, this voltage is approximately 35 volts, and it decreases with increasing capacitance, so that at 100 μf it is approximately one volt.

Polarizing Voltage: Terminals for connecting a d-c polarizing voltage are provided on the panel.

Power Supply: 105 to 125 volts, 60 cycles. The power input is 15 watts.

Controls: Capacitance dial and multiplier, dissipation factor control and multiplier, sensitivity control.

Accessories Supplied: A line connector cord.

Vacuum Tubes: One each 6X5GT/G, 6J7, 6E5; all are supplied with the bridge.

Mounting: Portable carrying case, of airplane-luggage construction.

Dimensions: (Length) 14 $\frac{1}{2}$ x (width) 15 x (height) 9 $\frac{1}{4}$ inches, over-all, including cover and handles.

Net Weight: 19 pounds.

| Type | Code Word | Price |
|-------|-----------|----------|
| 740-B | BABEL | \$192.50 |

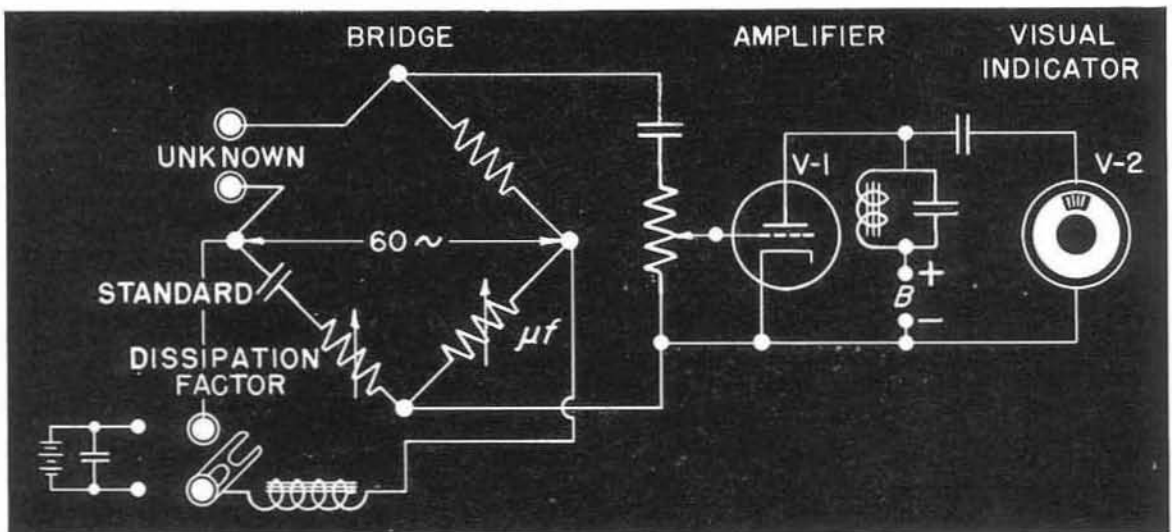

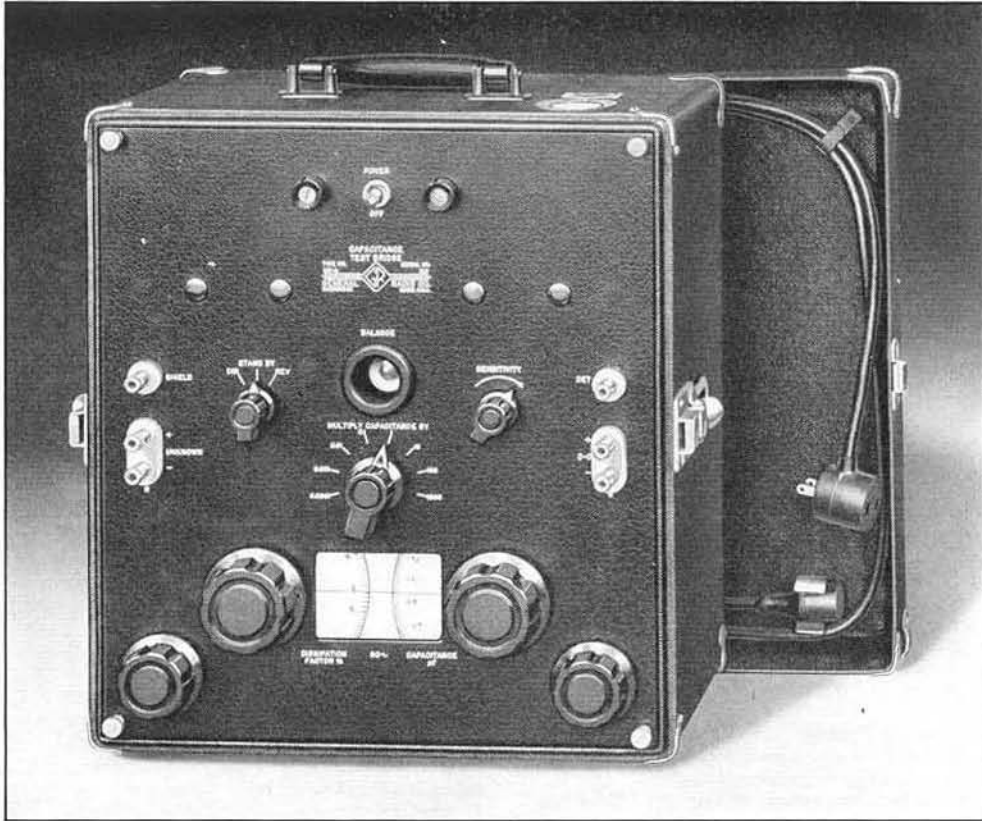

TYPE 1611-A CAPACITANCE TEST BRIDGE

USES: The TYPE 1611-A Capacitance Test Bridge is designed for 60-cycle capacitance and dissipation factor measurements over very wide ranges. It is suitable for laboratory or shop testing of all kinds of paper, mica, and electrolytic capacitors. It also meets the requirements of the electric power industry for shop testing of insulators, particularly for measurement of dissipation factor of bushings, insulators, the insulation of transformers, rotating machinery and cables. It can be used in such measurements even where there are adjacent bus potentials of several thousand volts.

For the wire and cable manufacturer, this bridge offers a convenient and rapid means for locating breaks in cable, and for laboratory and production tests of dissipation factor and capacitance on all kinds of cable.

The communications industry will find it useful not only for routine capacitance and dissipation factor tests on component capacitors but also for checking capacitance to ground of transformer windings, shields, and circuit elements.

DESCRIPTION: The circuit used is the series-resistance capacitance bridge. One ratio arm is continuously variable and calibrated to read directly in capacitance. The other ratio arm is variable in decade steps and serves as a multiplier for the direct-reading dial. The variable resistors in series with the standard capacitors are calibrated directly in dissipation factor.

Provision is made for conveniently applying an external d-c polarizing voltage to the capacitor under test.

A visual null indicator is used, consisting of a tuned amplifier and an electron-ray tube. The circuit is so designed that maximum sensitivity is obtained at balance, with reduced sensitivity off balance. This arrangement greatly facilitates the finding of the balance point. The detector system can be made linear and more suitable for limit testing by changing one tube.

A portable luggage-type carrying case houses the complete instrument.

FEATURES: ▶ Nine decades of capacitance values are covered by the TYPE 1611-A Ca-

capacitance Test Bridge so that the value of every capacitor under 11,000 μf falls within its range.

- ▶ No accessories are required and the bridge is ready for operation as soon as it is connected to the power line.
- ▶ The visual indicator allows the bridge to be used in noisy locations where head telephones would be useless.
- ▶ The detector system is very sensitive when the bridge is near balance, but relatively insensitive when out of balance. This characteristic greatly simplifies the process of locating the balance point.
- ▶ The low test voltage used by the bridge

makes it possible to save considerably in size and cost over high-voltage equipment. Comparative dissipation-factor measurements on bushings have shown that the magnitude of the test voltage has practically no effect on the results when the test voltage is only a fraction of the operating voltage.

- ▶ Moderate electrostatic fields such as might be encountered in laboratories with overhead voltages of several thousand volts do not destroy the usefulness of the instrument. In cases where the overhead voltages are greater than several thousand volts, the bridge cannot be used satisfactorily unless sufficient external shielding of the bushings is provided.

SPECIFICATIONS

Capacitance Range: 0 to 11,000 μf , covered by eight multiplier steps and an approximately logarithmic, direct-reading dial.

Dissipation-Factor Range: 0 to 30% (at 60 cycles), covered by one dial having an approximately logarithmic scale.

Capacitance Accuracy: $\pm(1\% + 1 \mu\text{f})$ over the entire range of the bridge.

Dissipation Factor Accuracy: $\pm(2\%$ of dial reading $+ 0.05\%$ dissipation factor). Power Factor = $\frac{D}{\sqrt{1 + D^2}}$, where D = dissipation factor.

Sensitivity: The sensitivity is such that any capacitance in the range 100 μf to 10,000 μf can be balanced to a precision of at least 0.1%.

Temperature and Humidity Effects: The readings of the bridge are unaffected by temperature and humidity variations over the range of room conditions normally encountered (65° F to 95° F, 0 to 90% RH).

A-C Voltage Applied to Capacitance under Test: The voltage impressed on the unknown capacitance varies from a maximum of approximately 125 volts at

100 μf to less than 3 volts at 10,000 μf . The circuit is so arranged that a maximum of one volt-ampere of reactive power is delivered to the sample.

Polarizing Voltage: Terminals are provided for connecting an external d-c polarizing voltage. The maximum voltage that should be impressed is 500 volts.

One of the terminals is grounded so that any a-c operated power supply with grounded output can be used. The terminal capacitances of the power supply do not affect the bridge circuit.

Power Supply Voltage: 105 to 125 (or 210 to 250) volts, 60 cycles.

Power Input: 15 watts.

Accessories Supplied: Line connector cord.

Mounting: Portable carrying case of luggage-type construction. Case is completely shielded to insure freedom from electrostatic pickup.

Vacuum Tubes: One each 6X5-GT, 6SJ7, and 6U5. All are supplied.

Net Weight: 30 $\frac{1}{2}$ pounds.

Dimensions: (Width) 14 $\frac{1}{2}$ x (depth) 16 x (height) 10 inches, overall, including cover and handles.

| Type | | Code Word | Price |
|--------|-----------------------------------|-----------|----------|
| 1611-A | Capacitance Test Bridge | FORUM | \$375.00 |

Schematic diagram of the TYPE 1611-A Capacitance Test Bridge. Generator and detector connections are interchanged by the switching when the bridge is used to measure capacitances greater than 1 μf .

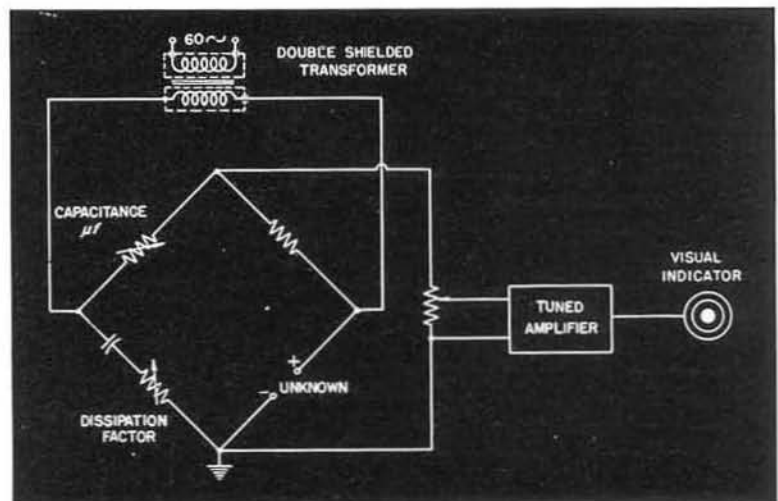

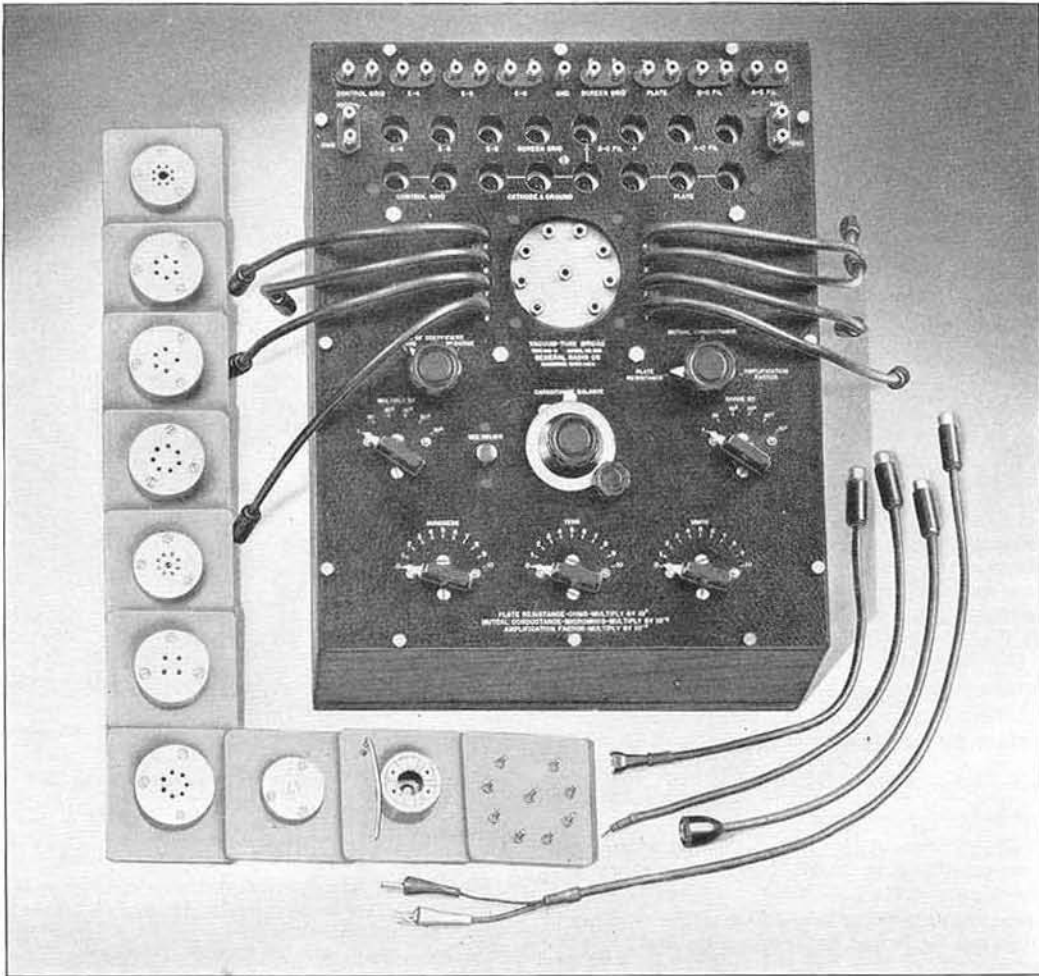

TYPE 561-D VACUUM-TUBE BRIDGE

USES: This instrument makes possible accurate measurements of the three fundamental vacuum-tube parameters: amplification factor, transconductance, and plate resistance, over wide ranges of values. The accuracy is sufficient so that the bridge has found acceptance among tube manufacturers as a standard of reference for tube measurements, particularly where extreme values of the parameters are encountered and where ordinary measuring circuits become untrustworthy.

In the field of development and research the instrument, in addition to providing accurate measurements of the usual tube parameters, affords a means of studying the behavior of tubes used in unconventional and special circuits, when any one of the electrodes may be used as the operating electrode and where the parameters may have negative values.

The tube circuits have large enough current-carrying capacity and sufficient insula-

tion so that low-power transmitting tubes may be tested in addition to receiving tubes.

DESCRIPTION: The bridge makes use of alternating-current null methods of measurement, in which phase shift and capacitance errors have been given special consideration in order that the operating range of the bridge may be as wide as possible. Each of the three coefficients is obtained in terms of the ratio of two alternating test voltages. A third voltage is employed in the capacitance balancing circuit, but its value does not enter into the results.

An extremely flexible arrangement of the tube control circuits makes it possible to measure the tube parameters referred to any pair of electrodes. Connections from the tube under test to the measuring circuit are made by means of concentric cables and jacks, connected to an eight-terminal jack plate, mounted on the panel. Sixteen concentric

plugs are mounted on the panel, permitting a wide variety of interconnections between the jack plate, the measuring circuit, and external batteries.

Ten adapter plug plates are provided. Nine of these carry different standard tube sockets, and one is a "universal" adapter furnished with soldering lugs.

FEATURES: ▶ A simple and straightforward measurement procedure is used and is exactly the same for all three coefficients. A three-position switch is turned to the desired quantity, multiplier switches are set at the appropriate value for the tube being tested, and a null balance is obtained by adjusting a three-decade attenuator and a variable capacitor. At balance, the decades read the quantity being measured directly to three significant figures.

▶ Independent measurements of the three main tube parameters are possible, i.e., none of the balances depends in any way on any other. Therefore independent cross checks can be obtained from the known relationship involving the three coefficients.

▶ Negative values of the tube coefficients can be measured as readily as positive values.

▶ Interelectrode capacitance effects are balanced out by a method which makes possible the independent measurement of all three parameters over very wide ranges. Errors have thus been reduced, and it is possible to measure the transconductance of a tube having a high value of grid to plate capacitance without any error from this capacitance.

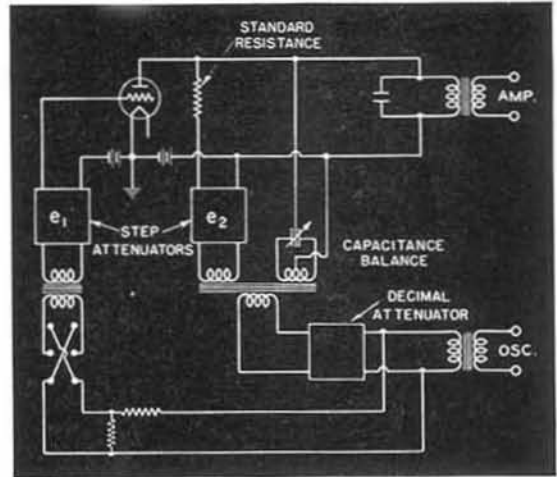

Simplified diagram of the circuit employed for the measurement of transconductance with the TYPE 561-D Vacuum-Tube Bridge. The a-c plate current resulting from the application of e_1 to the grid is balanced by an equal and opposite current applied to the plate from the source e_2 , through the standard resistance. The setting of the decimal attenuator at the bottom of the panel gives the significant figures in the result, and the settings of the step attenuators (e_1 and e_2) indicate multiplying factors (MULTIPLY BY and DIVIDE BY on the panel switches).

Any quadrature component through the output transformer resulting from the tube interelectrode capacitances can be balanced out by the voltage of the extra split secondary, acting through the double-stator capacitor. This balance does not affect the balance conditions for the in-phase components and consequently has no effect on the measurement.

The points of introduction of the test voltages e_1 and e_2 are changed by a switch when the other constants are measured. Another switch reverses the polarity of e_1 when negative values of the coefficients are to be measured.

SPECIFICATIONS

Range: Amplification factor (μ); 0.001 to 10,000.
Dynamic internal plate resistance (r_p); 50 ohms to 20 megohms.

Transconductance (s_m); 0.02 to 50,000 micromhos.

Under proper conditions, the above ranges can be exceeded. The various parameters can also be measured with respect to various elements, such as screen grids, etc. Negative, as well as positive, values can be measured.

Accuracy: Within $\pm 2\%$ for resistances (r_p switch position) from 1000 to 1,000,000 ohms. At lower and higher values the error increases slightly.

The expression $\mu = r_p s_m$ will check to $\pm 2\%$ when the quantities are all measured by the bridge, and when r_p is between 1000 and 1,000,000 ohms.

Tube Mounting: Socket adapters are provided, as follows: 4-prong, 5-prong, 6-prong, small 7-prong, medium 7-prong, octal, loctal, miniature 7-prong, and acorn (5- and 7-prong). Thus all standard commercial receiving tubes can be measured. In addition, a "universal" adapter, with eight soldering lugs, is provided so that unmounted tubes, or tubes with non-standard bases, can be measured conveniently. The panel jack plate and the adapters are made of low-loss yellow phenolic, reducing to a minimum the shunting effect of dielectric losses on the dynamic resistance being measured.

Accessories Supplied: Two TYPE 274-NE Shielded Connectors for connecting bridge to oscillator and detector, two grid-lead connectors and one special connector.

Current and Voltage Ratings: The tube circuits have large enough current-carrying capacity and sufficient insulation so that low-power transmitting tubes may be tested in addition to receiving tubes. Maximum allowable plate current is 150 ma and maximum plate voltage is 1500 volts.

Electrode Voltage Supply: Batteries or suitable power supplies are necessary for providing the various voltages required by the tube under test.

Bridge Source: A source of 1000 cycles is required. The TYPE 813-A Audio Oscillator or the TYPE 723-A Vacuum-Tube Fork is suitable for this purpose.

Null Indicator: An amplifier in conjunction with a sensitive pair of head telephones is recommended.

Mounting: The instrument is mounted in a walnut cabinet. A wooden storage case is provided for the plug plates and leads.

Dimensions: (Length) $18\frac{3}{4}$ x (width) $15\frac{3}{4}$ x (height) 11 inches.

Net Weight: 51 pounds.

| Type | Code Word | Price |
|-------------------------------|-----------|----------|
| 561-D Vacuum-Tube Bridge..... | BEIGE | \$550.00 |

TYPE 544-B MEGOHM BRIDGE



USES: The megohm bridge is very useful for measuring all types of resistances in the megohm ranges. These uses include not only the resistance of cartridge-type resistors used as grid leaks and coupling resistors in vacuum-tube circuits, but also the insulation resistance of electrical machinery such as generators, motors, and transformers; of electrical equipment such as rheostats and household appliances; of single conductors, cables, and capacitors; of sufficiently long sections of high-voltage cables; of paper capacitors; and of slabs of insulating materials. Volume resistivity and its change with temperature and humidity can be determined. Guard connections are provided for the measurement of three-terminal resistors such as multi-wire cables, three-terminal capacitors, networks, and guarded specimens of insulating materials.

This bridge has been widely used for measuring the dielectric absorption effects in the insulation of electrical machinery, trans-

formers, and cables. Charging-current curves can be easily obtained, over time intervals from one second to many hours.

DESCRIPTION: The TYPE 544-B Megohm Bridge is a combination of Wheatstone bridge and vacuum-tube voltmeter.

The bridge is composed of the four arms, A , B , N , P , as shown for the OPERATE position in the diagram at the bottom of the next page, with the power applied across the arms, A and B , and the vacuum-tube voltmeter connected across the conjugate pairs, $A-N$ and $B-P$. For checking the galvanometer zero, the tube is isolated from the bridge voltage as shown in the CHECK position, with the high resistors, N and P , connected to the grid exactly as in the OPERATE position. The effects of any voltages, alternating or direct, in the unknown resistor, P , and of any grid current of the tube will not appear in the bridge balance because they are balanced out in the zero adjustment. There is also a CHARGE position, in which the unknown resistor, P , is placed across the arm, B . This is valuable in measuring the resistance of large capacitors because full voltage is applied directly to the capacitor which can then charge at a maximum rate. The zero of the galvanometer can also be checked at any time without being affected by the residual charge in the capacitor.

FEATURES: ▶ The direct measurement of resistances up to 1,000,000 megohms is made possible by the use of a vacuum-tube detector, which absorbs a negligible amount of power.

▶ Constant fractional accuracy, regardless of setting, is obtained by using a resistance scale that is approximately logarithmic over

Schematic circuit diagram of the Megohm Bridge.

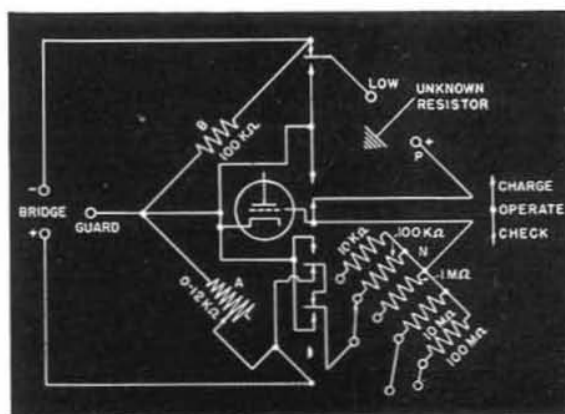

one decade. The effective scale length for the range from 100,000 ohms to 10,000 megohms is 35 inches.

► The voltage applied to the unknown resistance is held approximately constant, regardless of the value of the unknown resistance. This condition is necessary to measure insulation resistance properly.

► Voltage stabilization is used in the a-c power supply to prevent surges in charging current when the leakage resistance of capacitors is measured.

SPECIFICATIONS

Range: 0.1 megohm to 1,000,000 megohms, covered by a dial and a 5-position multiplier switch. A resistance of 1,000,000 megohms can be distinguished from infinity.

| Accuracy: | Resistance | Accuracy |
|-----------|---------------------|----------|
| | .1 MΩ — 100 MΩ | ± 3% |
| | 100 MΩ — 1000 MΩ | ± 6% |
| | 1000 MΩ — 10,000 MΩ | ± 10% |

Above 10,000 megohms, the accuracy is essentially that with which the scale on the MEGOHMS dial can be read.

Terminals: All high-voltage terminals are insulated as a protection to the operator. A maximum of 12 ma can be drawn on short circuit.

Power Supply: Two types of power supply are available: (1) an a-c unit delivering d-c test voltages of 500 volts and 100 volts to the bridge, and (2) a battery power supply of 90 volts. The a-c unit operates from a 105- to 125-volt (or 210- to 250-volt), 40- to 60-cycle line. The battery power supply consists of 2 No. 6 Dry Cells and 3 Burgess No. 5308 45-volt batteries.

Operating Voltage: Terminals are provided so that the bridge voltage can be obtained from an external source if desired. Up to 500 volts can be applied.

Vacuum Tubes: With battery power supply, a 1D5-GP detector tube is used; the 500-volt power supply uses a



The MEGOHMS dial of TYPE 544-B Megohm Bridge. The scale is approximately logarithmic over the main decade from 1 to 10.

6K7-G detector, a 6X5-GT/G rectifier, a 5U4-G rectifier, and, in the voltage regulators, a 6J5-GT/G, a 6K6-GT/G, a 4A1 Ballast Tube, and two TYPE 2LAG-949 neon lamps. All tubes are supplied.

Accessories Supplied: With a-c power supply, a seven-foot line-connector cord and spare fuses. Batteries are supplied with the battery-operated model.

Mounting: Shielded oak cabinet.

Dimensions: Cabinet with cover closed, (width) 8 1/2 x (length) 22 1/2 x (height) 8 inches, over-all.

Net Weight: With battery power supply, 29 1/2 pounds; with a-c power supply, 26 3/8 pounds; Type 544-P10, 14 1/4 pounds; Type 544-P3, 11 1/8 pounds.

| Type | Description | Code Word | Price |
|---------|---|------------|----------|
| 544-B | Megohm Bridge, with A-C Power Supply | AGREE | \$295.00 |
| 544-B | Megohm Bridge, Battery Operated (Incl. Batteries) | ALOOF | 215.00 |
| 544-P3 | A-C Power Supply Unit Only | AGREEAPACK | 105.00 |
| 544-P10 | Battery Power Supply Unit Only | ALOOFAPACK | 22.00 |

TYPE 729-A and TYPE 1861-A Megohmmeters, direct-reading instruments operating on the ohmmeter principle, are described on pages 151 and 152.

These diagrams show the bridge connections for the three positions of the CHECK-OPERATE-CHARGE switch.

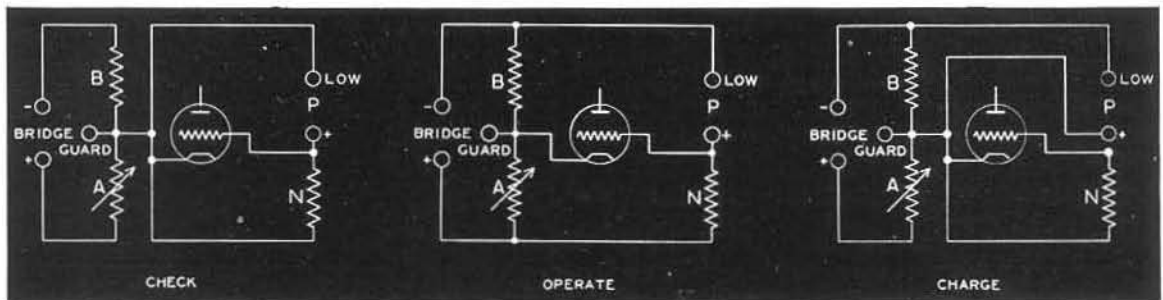

TYPE 1614-A CAPACITANCE BRIDGE

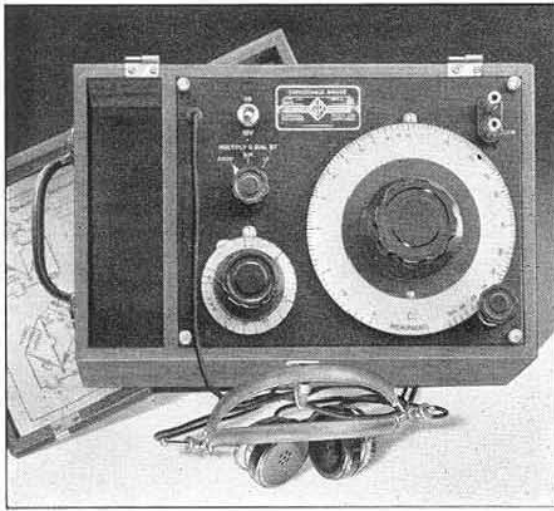

USES: Designed for the rapid measurement of capacitors in industrial plants, the TYPE 1614-A Capacitance Bridge finds applications in both production testing and in the laboratory. It is suitable for acceptance tests by both the manufacturer and the user of the many types of paper, mica, and electrolytic capacitors used in electrical equipment, and in the laboratory it is a handy means of making rapid checks on the condition of capacitors used in experimental circuits.

DESCRIPTION: This bridge is portable and operates from self-contained batteries. The measuring frequency is 1000 cycles, supplied by an internal electro-mechanical oscillator. A pair of head telephones, internally attached, are used in indicating balance. When not in use, the phones are stored in a compartment in the walnut cabinet. A removable hinged cover affords protection for the instrument, and a carrying handle is provided. Operating instructions are attached to the inside of the cover.

The circuit is that of a conventional 4-arm bridge, in which the loss component of the unknown is balanced by means of a variable resistor in series with the standard capacitor. Provision is made for introducing a polarizing voltage, from an external source, in measuring electrolytic capacitors.

The capacitance of the unknown is indicated directly by the setting, at balance, of a 6-inch dial with slow-motion drive. A separate 3-position switch provides multiplying factors in steps of 100:1. The second balance control is a $2\frac{3}{4}$ -inch dial that reads directly in dissipation factor.

FEATURES: Portability, ease of operation, and simplicity, combined with wide range and good accuracy are some of the principle features of this bridge.

SPECIFICATIONS

Capacitance Range: 10 μf to 100 μf in three steps: 10 μf to 10,000 μf ; 0.01 μf to 1.0 μf ; and 1.0 μf to 100 μf .
Accuracy: $\pm 2\%$, except on the lowest range, where, after the zero capacitance is subtracted, the accuracy is $\pm (2\%$ of the dial reading $+ 2\mu\text{f})$.

Dial Calibration: Approximately logarithmic (uniform fractional accuracy) over two main decades, with a compressed lower decade which is used only for measurements below 100 μf .

Dissipation Factor: Range, 0 to 45%. Accuracy: On the lowest capacitance range, the error, expressed in percent dissipation factor, is $\pm (0.1 \times \text{dial reading} + 2)\%$; on the other two ranges, $\pm (0.1 \times \text{dial reading} + 0.2)\%$.

Frequency: The internal oscillator furnishes the necessary bridge power at a frequency of 1000 cycles $\pm 5\%$.

Power Supply: 6-volt dry battery. Two Burgess F2BP units connected in series are recommended, and are supplied with the instrument, but space for these is provided in the cabinet.

Accessories Supplied: Head telephones and batteries.

Accessories Required: When a d-c polarizing voltage is used, a 2 μf by-pass capacitor is required. This capacitor is not supplied with the instrument, but space for a General Electric 55X-629 is provided in the cabinet.

Mounting: Walnut cabinet with removable hinged cover.

Dimensions: 13 $\frac{1}{2}$ x 8 $\frac{1}{2}$ x 7 inches, over-all.

Net Weight: 13 $\frac{1}{4}$ pounds.

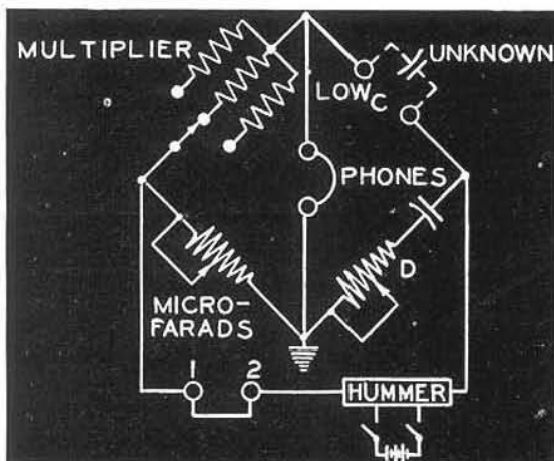

| Type | Code Word | Price |
|--------|-------------------------|----------|
| 1614-A | Capacitance Bridge..... | LAPEL |
| | | \$140.00 |

TYPE 1631-A INDUCTANCE BRIDGE

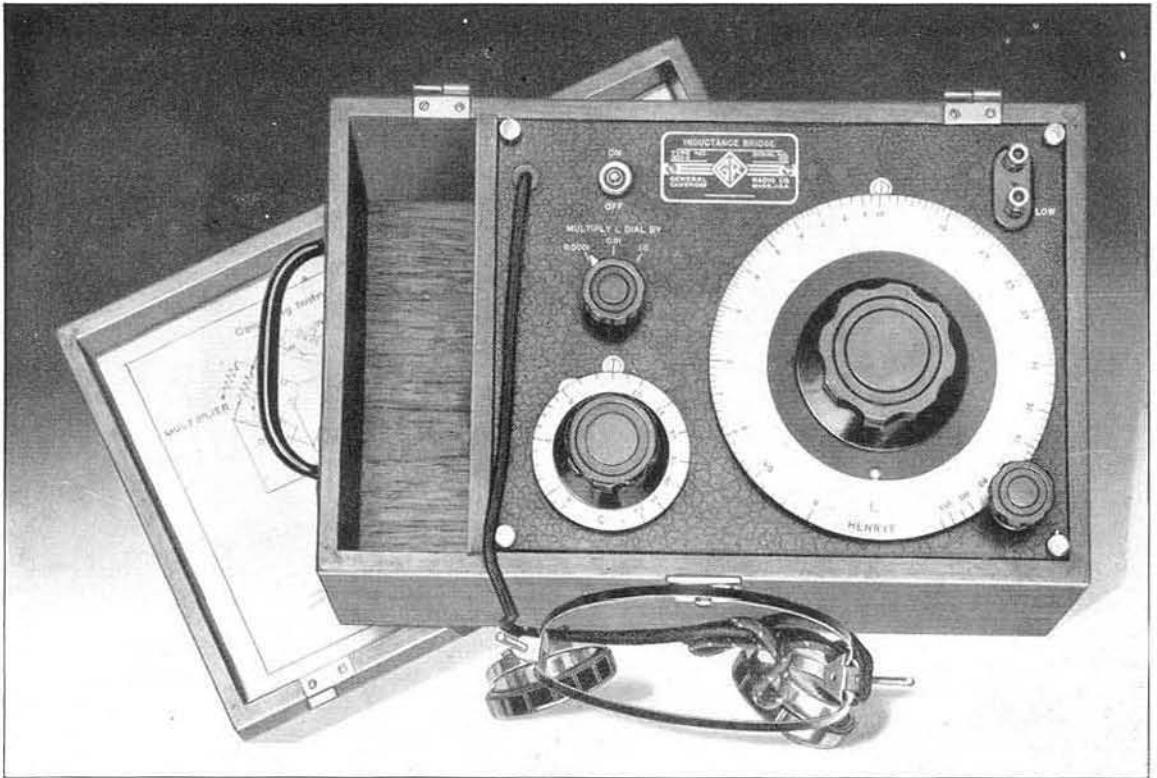

USES: This bridge, a companion instrument to the TYPE 1614-A Capacitance Bridge, is designed for the rapid measurement of the inductance and storage factor (Q) of inductors over a range of $100\ \mu\text{h}$ to $100\ \text{h}$. Less accurate measurements can be made of inductors between $10\ \mu\text{h}$ and $100\ \mu\text{h}$. It is suitable for production testing or for routine laboratory use. Iron-cored inductors can be measured at an arbitrary value of impressed a-c voltage which is substantially in excess of the value corresponding to initial permeability.

DESCRIPTION: Like the TYPE 1614-A Capacitance Bridge, this bridge is portable and operates from self-contained batteries. The

same type of oscillator and head telephones are used, and the bridge is housed in a similar cabinet. The circuit is that of the Maxwell bridge, in which a fixed capacitor is used as the standard, and the loss component is balanced by a variable resistor shunting the standard.

The inductance of the unknown is indicated directly by the setting, at balance, of a 6-inch dial with slow-motion drive. A 3-position switch provides multiplying factors in steps of 100:1. The second balance control is a $2\frac{3}{4}$ -inch dial calibrated directly in storage factor Q .

FEATURES: See TYPE 1614-A Capacitance Bridge on preceding page.

SPECIFICATIONS

Inductance Range: $10\ \mu\text{h}$ to $100\ \text{h}$ in 3 steps: $10\ \mu\text{h}$ to $10,000\ \mu\text{h}$; $0.01\ \text{h}$ to $1\ \text{h}$; and $1\ \text{h}$ to $100\ \text{h}$.

Accuracy: $\pm 2.5\%$ of dial reading between $100\ \mu\text{h}$ and $10\ \text{h}$. Below $100\ \mu\text{h}$ the error varies inversely as the magnitude of the unknown. Above $10\ \text{h}$ the error increases to $\pm 10\%$ of dial reading at $100\ \text{h}$.

Dial Calibration: Approximately logarithmic (uniform fractional accuracy) over two main decades, with a com-

pressed lower decade which is used only for measurements below $100\ \mu\text{h}$.

Q: Range, 1 to 45. Accuracy, $\pm 10\%$ of dial reading for values of Q between 2 and 10. For higher values the error increases progressively to $\pm 15\%$ at a Q of 45. For lower values, the error increases to $\pm 20\%$ at a Q of 1.

Other specifications are identical with those for TYPE 1614-A Capacitance Bridge, preceding page.

| Type | | Code Word | Price |
|--------|------------------------|-----------|----------|
| 1631-A | Inductance Bridge..... | LARVA | \$150.00 |



TYPE 1612-A R-F CAPACITANCE METER

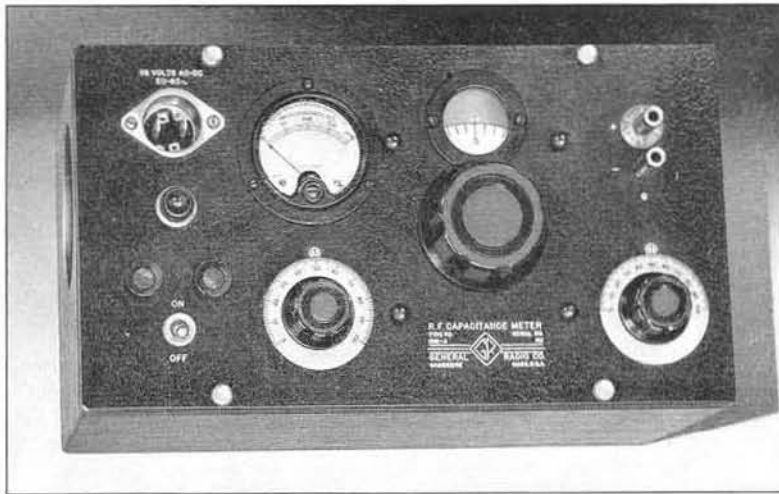

USES: The TYPE 1612-A R-F Capacitance Meter is a device for conveniently measuring capacitances up to 1200 μf . It can also be used for comparing the losses in dielectric samples.

DESCRIPTION: The principle of operation is illustrated by the functional circuit diagram below. The main elements are a one-megacycle oscillator and a measuring circuit.

The oscillator is loosely coupled to the measuring circuit, which incorporates a calibrated capacitor, an inductor, and a crystal rectifier and microammeter. Manual control of the oscillator output is provided.

Measurement is made by a substitution method in which the capacitance of the cali-

brated capacitor is reduced to re-establish resonance after the unknown capacitance is connected to the X terminals.

The instrument operates directly from a 115-volt, a-c or d-c line.

FEATURES: ▶ Ease and speed of measurement are outstanding characteristics.

▶ The range of the instrument covers capacitors commonly used in r-f circuits.

▶ Comparative measurements of dielectric losses are readily made.

▶ The meter is simple and accurate and has no complicated circuits.

▶ Ac or dc can be used to furnish the necessary power.

SPECIFICATIONS

Capacitance Range: 0 to 1200 μf in two ranges—0 to 80 μf and 0 to 1200 μf . Ranges are switched automatically as capacitance dial is rotated.

Capacitance Accuracy: Low Range: From 0 to 50 μf , $\pm(3\% + 0.3 \mu\text{f})$. Between 50 and 80 μf , $\pm 6\%$. High Range: From 0 to 1200 μf , $\pm(3\% + 5 \mu\text{f})$.

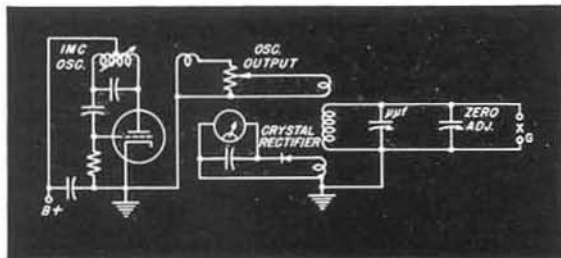

Dielectric Losses: Relative meter indications with different dielectric samples give a comparative measure of dielectric loss.

Oscillator Frequency: 1 megacycle $\pm 1\%$ adjusted at factory. Frequency can be readjusted if necessary by means of a movable dust core.

Resonance Indicator: A 1N34 crystal rectifier is used with a microammeter to indicate resonance.

Tube: A 117N7-GT tube is used in the oscillator circuit, and is supplied.

Power Supply: 115 volts, 50 to 60 cycles ac, or dc.

Power Input: 12 watts at 115 volts, ac. 11 watts at 115 volts, dc.

Dimensions: (Length) 12 x (height) 6 $\frac{5}{8}$ x (depth) 7 $\frac{1}{2}$ inches, over-all.

Net Weight: 11 pounds, 10 ounces.

| Type | Code Word | Price |
|-------------------------------------|-----------|----------|
| 1612-A R-F Capacitance Meter..... | AFTER | \$155.00 |



TYPE 1670-A MAGNETIC TEST SET

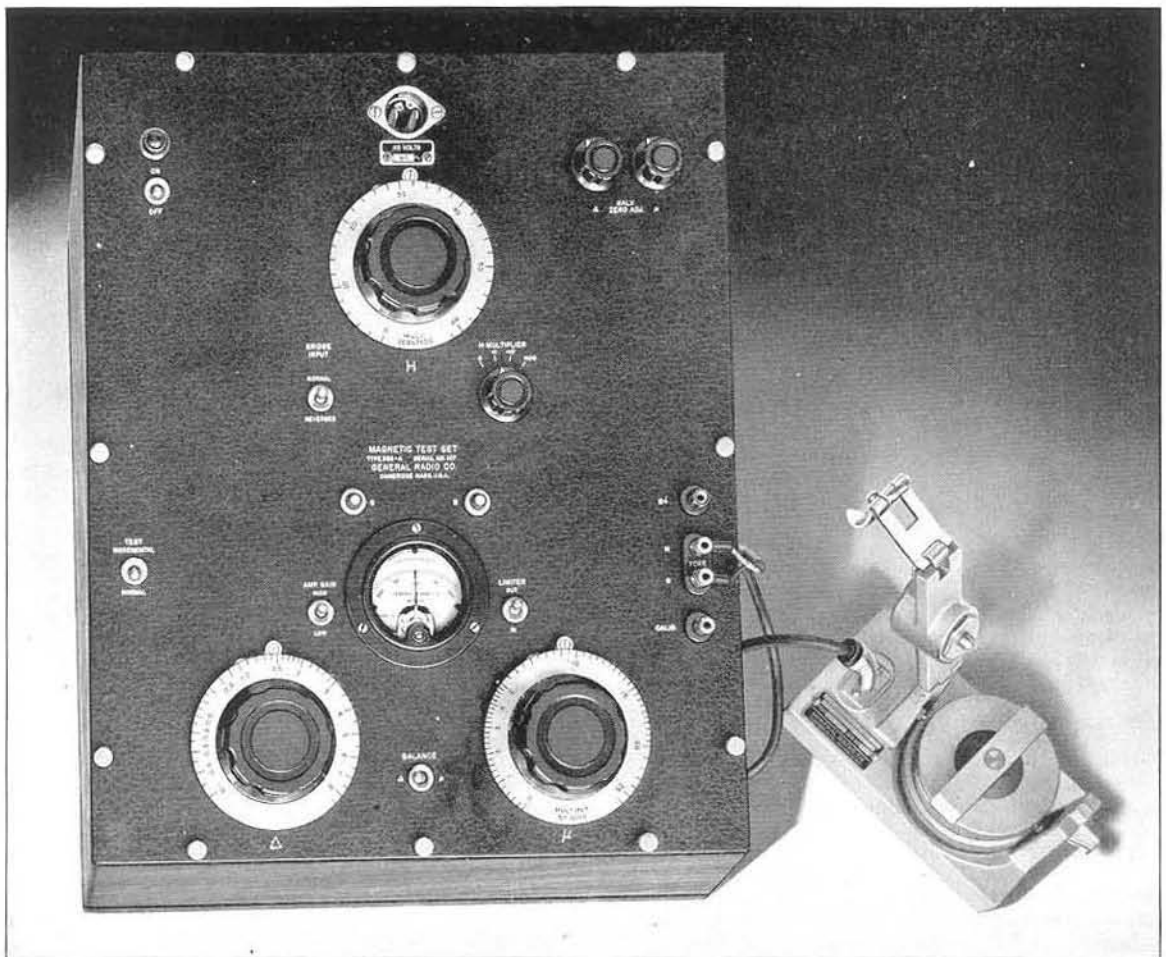

USES: This equipment is designed to furnish convenient and rapid 60-cycle measurements of the permeability and core loss of small samples of laminated ferromagnetic material, such as might be cut from transformer laminations. Such samples may have a width up to $\frac{3}{8}$ inch and any length in excess of $2\frac{1}{4}$ inches, and may be measured individually or in parallel combinations. They can be cut in any desired direction.

DESCRIPTION: The method of measurement uses a Maxwell bridge in conjunction with a phase-sensitive null detector. The measurement consists essentially of the determination of the inductance and the loss component of a solenoid built into the test yoke in which the sample is clamped. These parameters are interpreted as the permeability and core loss of the specimen material. Values of normal induction, B , (flux density) are directly calculable from these data. The test yoke is designed to have sufficient permeability and cross section so that its reluctance

is negligible compared to that of the specimen, up to medium permeabilities. Corrections can be made when measuring high-permeability materials.

The measurement is made under known conditions of 60-cycle normal magnetizing force, H , with provision for adjusting this parameter over a wide range. The magnetizing *current* is sinusoidal. Measurements close to initial permeability ($H =$ one millioersted) can be made, and a steady biasing magnetizing force (dc) can be superimposed, if desired, for incremental measurements.

The detector system consists of (1) a degenerative selective amplifier, (2) a phase-shifting network, which permits either of two phases, 90 degrees apart, to be selected, (3) a modulation bridge in which the zero-center galvanometer is connected, and (4) an amplitude-limiting network, which gives maximum sensitivity at balance, but prevents the galvanometer from going off scale.

A complete theoretical treatment of the method of measurement will be found in a

BRIDGES

paper by H. W. Lamson, entitled "A Method of Measuring the Magnetic Properties of Small Samples of Transformer Laminations," published in the *Proceedings of the Institute of Radio Engineers*, December, 1940.

FEATURES: ▶ Small rectangular strip samples are used for measurements with the TYPE 1670-A Magnetic Test Set. Thus it is not necessary to prepare special ring-shaped samples or to use the amount of material required to construct the standard Epstein test core.

▶ Independent indications of balance for the two main bridge controls are provided by means of the phase-shifting network. This feature eliminates the inconvenience of the sliding balance that is characteristic of the bridge when a conventional null detector is used.

▶ Direct comparison of the permeability of

various samples can generally be made from the bridge dial readings without the necessity of calculating absolute values.

▶ The direction of off-balance is indicated by means of the modulation bridge.

▶ Measurements analagous to Epstein values for power purposes can be made on 72-grade silicon steel or higher-permeability materials at B_{max} equal to 10,000 gauss.

▶ The high gain necessary for measurements at low values of magnetizing force is furnished by the degenerative selective amplifier, which also eliminates the effect of harmonic response at high values of magnetizing force.

▶ The limiting circuit prevents off-scale deflections of the meter, which is made to respond exponentially to the amount of off-balance. This arrangement eliminates the need of a gain control or adjustable galvanometer shunt.

SPECIFICATIONS

Range of Magnetizing Force: The 60-cycle normal magnetizing force is adjustable from one millioersted to 6 oersteds (gilberts per centimeter) for a line voltage of 115 volts. A biasing magnetizing force (dc) up to 2 oersteds can also be applied. The necessary d-c power, up to 1.5 oersteds, can be obtained from the internal power supply of the test set.

Permeability and Core-Loss Range: The range for permeability and core-loss measurements varies with the cross-section area. For a sample cross section of 10 sq. mm. full scale on the μ dial is 25,000. The permeability and core loss of any ferromagnetic sample can be measured if a sample of proper cross section is chosen. It may sometimes be necessary to calculate corrections for high-permeability materials.

Accuracy of Measurement: The accuracy of data obtained with this instrument is chiefly determined by the precision with which the cross-section of the spec-

imen is known. Similar samples of identical cross section can be compared, at any given H , with an accuracy of 1 to 2 percent.

Power Supply: 115 volts, 60 cycles; by a change of connections on the power transformer primary, the instrument can be operated from a 230-volt line.

Power Input: 90 watts.

Tubes: 2 6C8-G, 1 6X5-G, and 1 0D3/VR150.

Accessories Supplied: Test yoke and line cord.

Accessories Required: When a d-c magnetizing force is applied, a milliammeter and a rheostat for varying the dc are required. The TYPE 371-A 50,000 Ω Rheostat is suitable when the internal voltage source is used.

Mounting: The test set, exclusive of the test yoke, is housed in a walnut cabinet with sloping front panel.

Dimensions: Test set, (width) 16 x (depth) 18 x (height) 10 inches over-all; test yoke, 8 x 4 x 5 1/2 inches.

Net Weight: Test set, 44 pounds; test yoke, 10 pounds.

| Type | Code Word | Price |
|----------------------------------|-----------|----------|
| 1670-A Magnetic Test Set | AFIRE | \$585.00 |

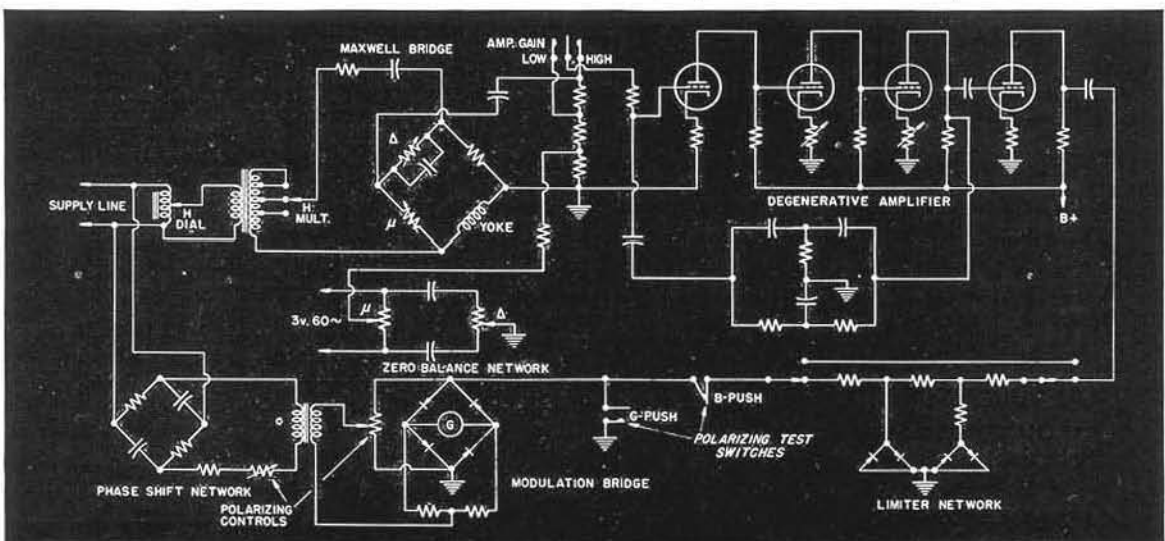

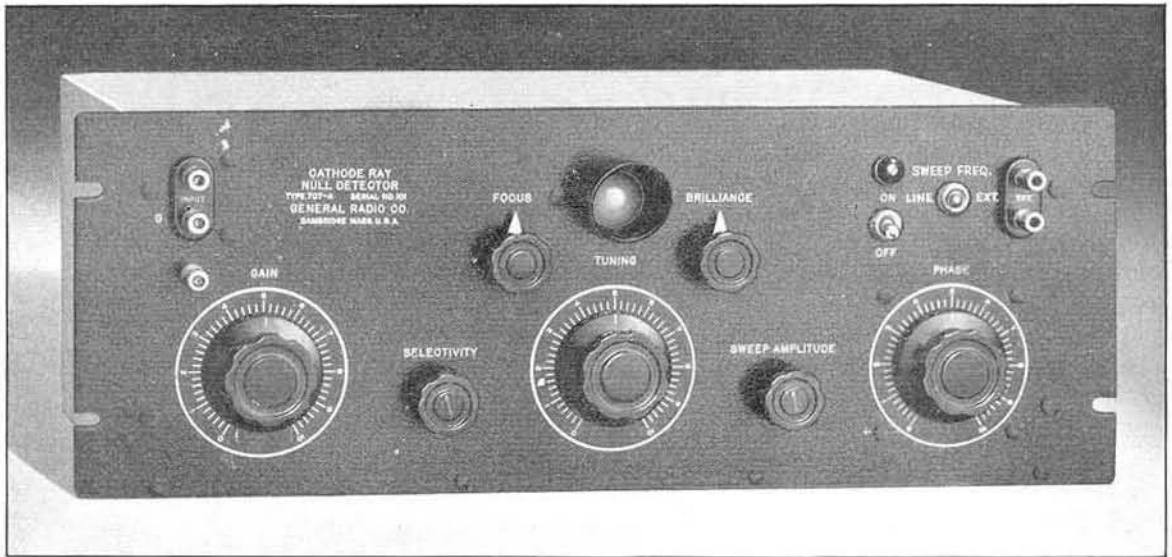

TYPE 707-A CATHODE-RAY NULL DETECTOR

USES: This visual null indicator is intended for use as a balance detector in bridge and other null-method measurements at power-line and audio frequencies. When calibrated for a given frequency, it can be operated as a limit indicator. It can also be used for comparing frequencies by means of Lissajous figures or, when calibrated, used as an a-c millivoltmeter.

DESCRIPTION: The output of the bridge is applied through an 80-db highly selective amplifier, operating on the degenerative principle, to the vertical deflecting plates of a one-inch cathode-ray tube. The bridge generator voltage is applied through an adjustable phase-shifting network to the horizontal plates. The tilted ellipse so formed is reduced to a horizontal straight line at balance.

FEATURES: ▶ Independent indications of the effect of balancing either the reactive or the resistive bridge control are given.

▶ Either bridge control can be balanced accurately without necessitating an accurate balance of the other. This arrangement makes rapid and convenient routine bridge measurements possible.

▶ Indication of the direction of off balance of either one of the bridge controls, chosen at will, is also given.

▶ Response and recovery are instantaneous and the null indicator cannot be injured by overloading.

▶ In noisy locations visual balancing is much less fatiguing than head telephones.

SPECIFICATIONS

Input Impedance: One megohm.

Sensitivity: 150 μv at 60 cycles; 200 to 300 μv at 1000 cycles.

Selectivity: 40 decibels against second harmonic.

Frequency Range: Plug-in units tune the amplifier for the desired operating frequency. See next page. Continuous tuning range $\pm 5\%$ for each unit.

Temperature and Humidity Effects: When this instrument is operated under severe conditions of temperature and humidity some decrease in sensitivity and selectivity may be expected. For the low frequency tuning units the sensitivity may be reduced by as much as 6 db, while for all units the selectivity to the second harmonic may be reduced by 5 db. The above figures are for a relative humidity of 80% at 95° Fahrenheit.

Controls: Panel controls are provided for adjusting the focus and brilliance of the cathode-ray pattern, the phase and amplitude of the horizontal sweeping voltage, and the gain, selectivity, and tuning of the amplifier.

Accessories Supplied: A 7-foot line connector cord.

Accessories Required: One plug-in phasing circuit is used at any frequency below 400 cycles; one plug-in tuning unit for each operating frequency used. These are not included in the price of the instrument. (See price list on next page.)

Power Supply: 105 to 125 volts, 40 to 60 cycles.

Power Input: 20 watts at 60 cycles.

Vacuum Tubes: One 6K7-G pentode, one 6F8-G twin triode, one 6J5-GT/G triode, one 913 cathode-ray tube, and one 6X5 rectifier; all are supplied with the instrument.

Mounting: Standard 19-inch relay-rack panel. Walnut end brackets are supplied for table mounting.

Dimensions: Panel, 19 x 7 inches; depth behind panel, 9 inches.

Net Weight: 29 pounds.

| Type | Code Word | Price |
|----------------------------------|-----------|----------|
| 707-A Cathode-Ray Null Detector* | NULTY | \$285.00 |

PATENT NOTICE. See Note 24, page vi. *Less Phasing Unit and Tuning Unit (see next page).



BRIDGES

**PLUG-IN UNITS FOR TYPE 707-A CATHODE-RAY
NULL DETECTOR**

These units are required for use with TYPE 707-A Cathode-Ray Null Detector and are not included in the price of that instrument.

A phasing unit is necessary for operation at any frequency *below* 400 cycles. At 400 cycles and above, none is required. A tuning unit is

required for each operating frequency. The tuning range is $\pm 5\%$ of the nominal frequency of any tuning unit.

All units plug into mounting jacks provided inside the null detector.

PHASING UNITS

| Type | Description | Code Word | Price |
|--------|--|------------|--------|
| 707-P1 | For Frequencies Below 100 cycles . . . | NULLTECANT | \$8.00 |
| 707-P2 | For Frequencies Between 100 and 400 cycles | NULLTECBOY | 8.00 |

AMPLIFIER TUNING UNITS

| Type | Frequency | Code Word | Price |
|-----------|-------------|------------|---------|
| 707-P50 | 50 cycles | NULLTECDOG | \$30.00 |
| 707-P60 | 60 cycles | NULLTECEYE | 30.00 |
| 707-P100 | 100 cycles | NULLTECTAP | 30.00 |
| 707-P400 | 400 cycles | NULLTECFIG | 30.00 |
| 707-P1000 | 1000 cycles | NULLTECGUM | 30.00 |
| 707-P2000 | 2000 cycles | NULLTECHIM | 30.00 |

Amplifier Tuning Units for special frequencies between 30 and 2000 cycles can be obtained on special order.

Schematic diagram for TYPE 707-A Cathode-Ray Null Detector.

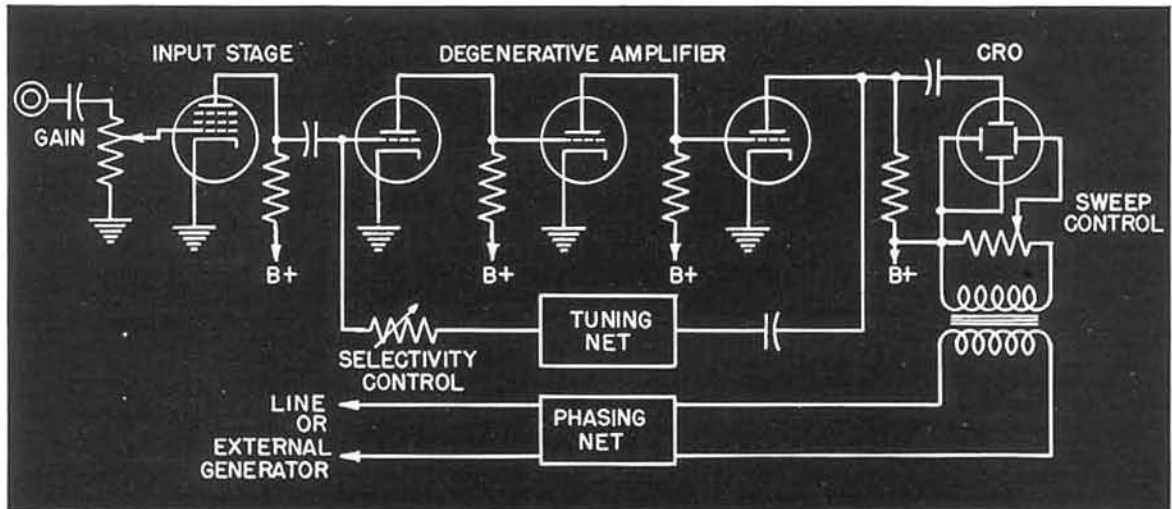

AMPLIFIERS AND POWER SUPPLIES



BRIDGE AMPLIFIERS

D-C AMPLIFIERS

LOW VOLTAGE
POWER SUPPLIES

UNIT LABORATORY
INSTRUMENTS

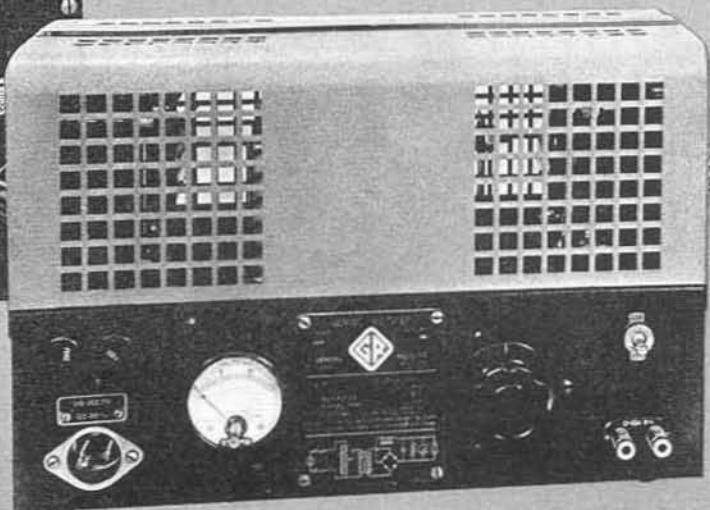
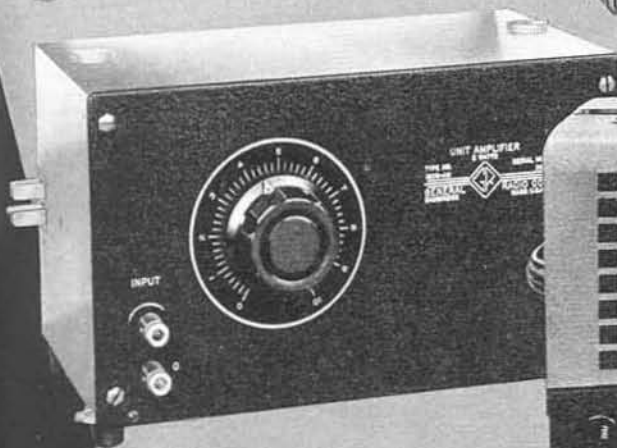
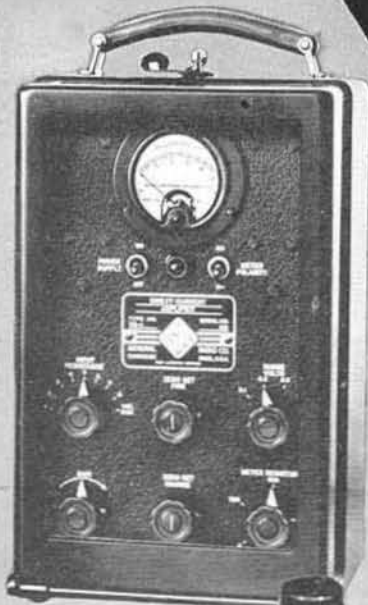

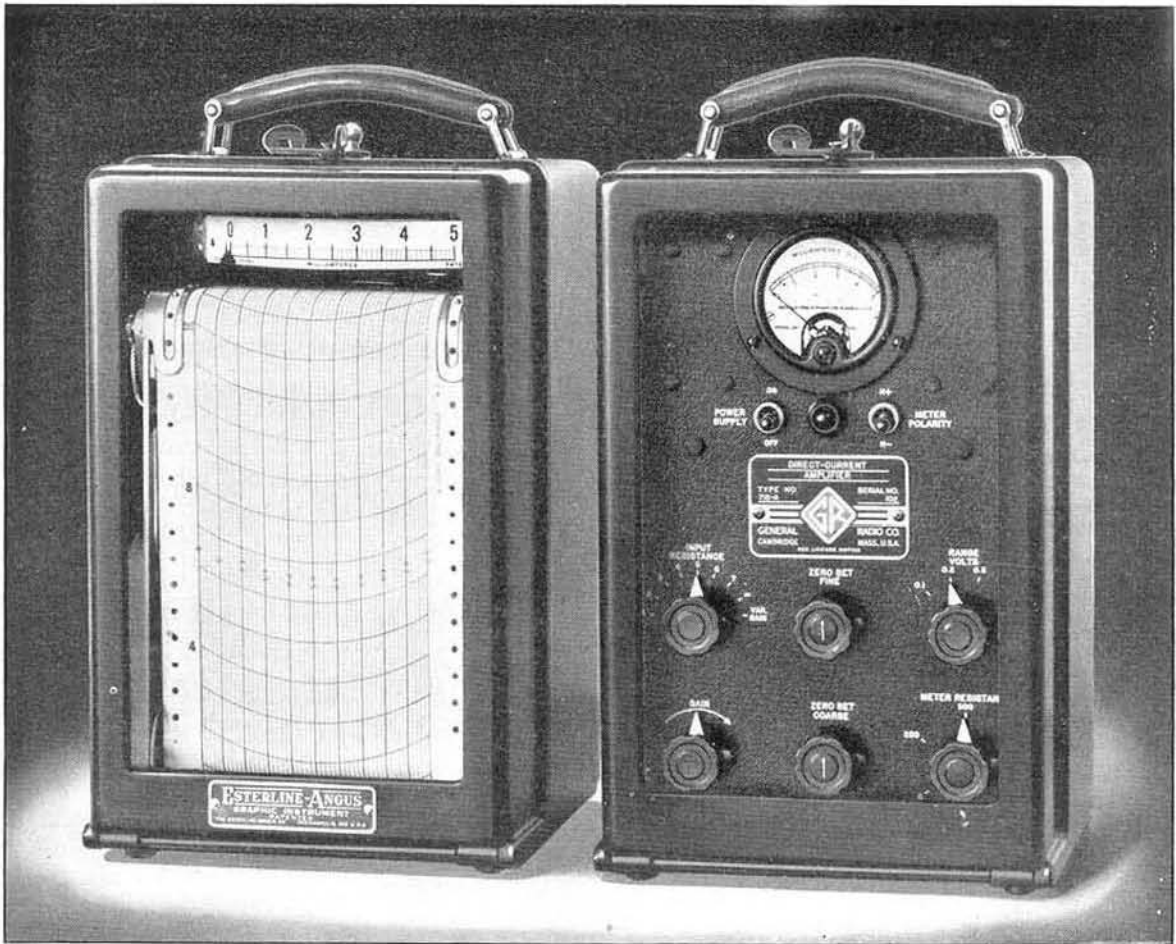

The TYPE 715-AE Direct-Current Amplifier with a 5-Ma Recorder.

TYPE 715-A DIRECT-CURRENT AMPLIFIER

USES: The TYPE 715-A Direct-Current Amplifier is designed primarily for use with the Esterline-Angus 5-milliampererecorder. This combination of amplifier and recorder is capable of accurately recording small d-c voltages and currents. In addition to its obvious use as a recording d-c milliammeter or millivoltmeter, it has a number of applications in process control and in measurements in physical and chemical laboratories.

Since the introduction of this amplifier, it has found application to a wide variety of industrial and research problems. It has been used for the recording of frequency and for recording the modulation level of broadcast transmitters. Other applications include the recording of the insulation resistance of electrical machinery during dehydration, the measurement of the emf of electro-chemical cells, the recording of life tests on vacuum

tubes, and the recording of sound and vibration intensities. The instrument may equally well be used to operate from photoelectric cells, resistance strain gauges, resistance thermometers, and similar devices.

DESCRIPTION: The amplifier is a highly stable a-c operated instrument and gives full-scale output over a range of input voltages from 0.1 volt to 1.0 volt. Means are provided for selecting input resistances between 100 ohms and 10 megohms.

The circuit employs three pentode tubes for the amplifiers in a degenerative circuit arrangement giving high stability of calibration. A bridge-type balancing network using a voltage regulator tube provides for balancing out the steady plate current in the meter, so that the meter indicates current change. Both fine and coarse zero adjustments are

provided for setting the meter for normal zero. The circuit is unaffected by changes in plate voltage caused by normal variations in a-c supply voltage.

- FEATURES:** ▶ High gain and simplicity of operation have been combined with stability of calibration.
- ▶ A wide range of input voltages and resistance combinations can be accommodated.

- ▶ Variations in the temperature of the cathode of the first amplifier tube, a critical point, have been overcome very effectively by using a regulating transformer and a filament ballast lamp. This system maintains the heater voltage constant for line voltage changes from 105 to 125 volts.
- ▶ A-c operation and small size make this amplifier a convenient adjunct to the graphic recorder.

SPECIFICATIONS

Range: The instrument is provided with four calibrated ranges; selected by means of a switch, giving 5 milliamperes linear output in the recorder circuit of 1000 ohms, for input voltages of 0.1, 0.2, 0.5, and 1.0 volt applied at the input terminals with either polarity. The gain is best expressed as a transconductance; the maximum value is 50,000 micromohms.

Accuracy: As a calibrated voltmeter, the accuracy of calibration is approximately 1% of full scale, this accuracy being maintained over a considerable period of time.

Input Circuit: Means are provided for selecting any one of a number of input resistances, so that the instrument not only has an adjustable input resistance, but can serve as a calibrated millivoltmeter or microammeter. The input resistances range in powers of 10 from 100 ohms to 10 megohms. Short-circuit and open-circuit positions are also supplied on the selector switch.

For those applications where relative values only are of interest and where the voltage available exceeds 1 volt, one of the switch positions connects the input to a variable gain control, so that the voltage applied to the first grid can be adjusted to any desired value. The input resistance for this position is approximately 150,000 ohms.

Grid Current: The grid current in the input circuit is less than 0.002 microampere.

Output Circuit: The output circuit is designed to operate a 5-milliamper meter mounted on the panel and an external meter or device such as the Esterline-Angus 5-milliamper recorder, and is provided with a manually adjusted compensating resistance. The compensating resistance is adjusted to allow for the resistance of the external device, so that the instrument always works into a normal resistance of 1000 ohms. Although the instrument functions perfectly when operating into resistances from 0 to 2000 ohms, its calibration is affected slightly if the total impedance deviates materially from the 1000-ohm value.

Temperature and Humidity Effects: Over the range of room conditions normally encountered (65° Fahrenheit to 95° Fahrenheit; 0 to 95% relative humidity), the operation and stability are independent of ambient conditions.

Power Supply: The instrument is intended for operation directly from 105 to 125 (or 210 to 250) volts, 60 cycles. Other voltages or other frequencies can be supplied on special order only.

Power Input: The power drawn from the 60-cycle line is approximately 35 watts. No batteries of any kind are employed.

Vacuum Tubes: The tubes used are: two 6J7-G, one 6F6-G, one 6X5-G, one 0C3/VR105, one 4A1. All are furnished with the instrument.

Mounting: The amplifier is mounted in a cast metal case identical with that used on the Esterline-Angus recorder, or in walnut cabinet, as desired.

Accessories Supplied: Seven-foot line connector cord.

Dimensions: TYPE 715-AM, (height) 15 1/4 x (width) 9 x (length) 8 1/2 inches, over-all; TYPE 715-AE, (height) 15 x (width) 8 1/2 x (length) 8 3/4 inches, over-all.

Net Weight: With cast metal case to match Esterline-Angus recorder, 25 3/4 pounds; with walnut cabinet, 22 1/4 pounds.

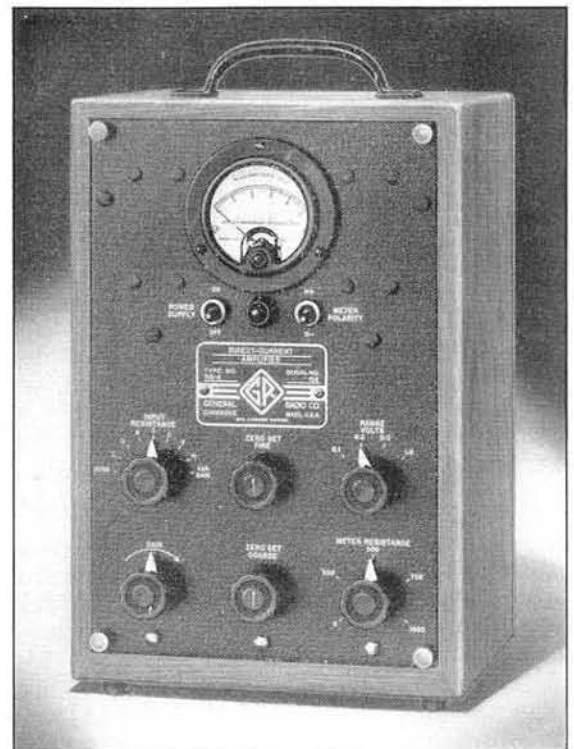

The TYPE 715-AM Direct-Current Amplifier.

| Type | Code Word | Price |
|--------|-----------|----------|
| 715-AE | ASIDE | \$345.00 |
| 715-AM | ALOFT | 300.00 |

PATENT NOTICE. See Note 1, page vi.

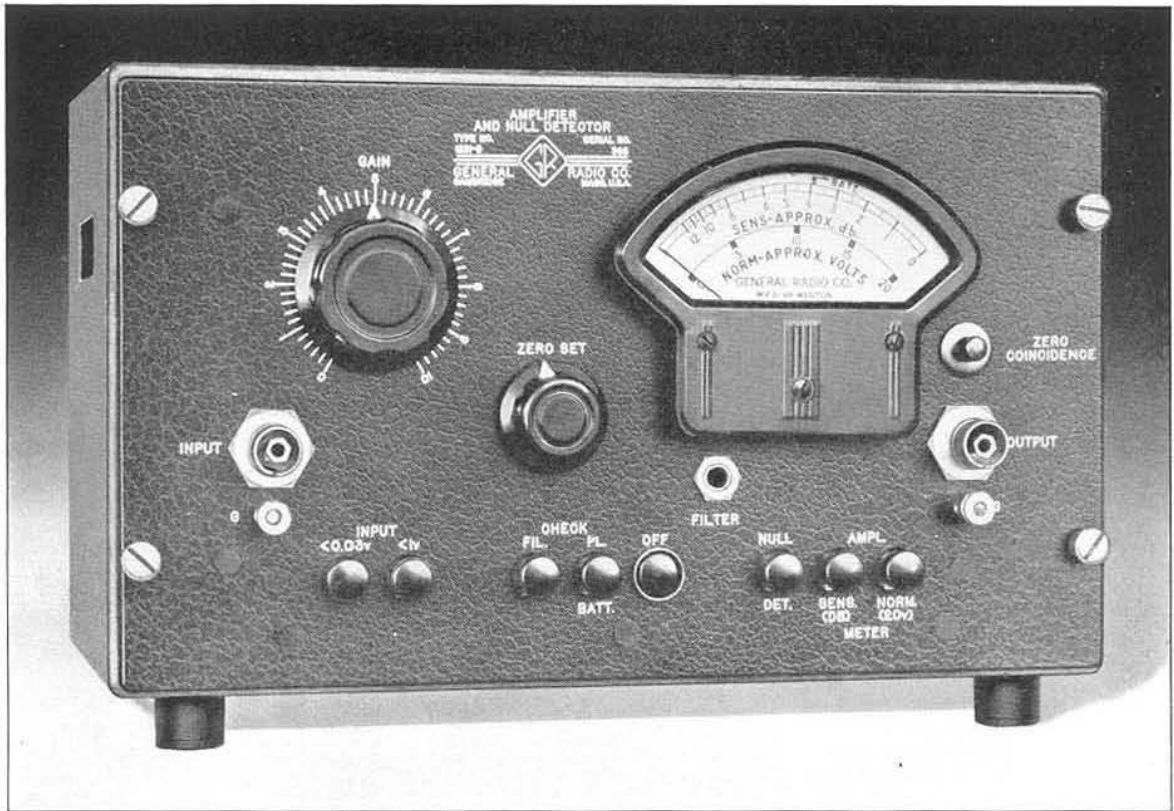

TYPE 1231-B AMPLIFIER AND NULL DETECTOR

USES: The TYPE 1231-B Amplifier and Null Detector can be used as a high-gain amplifier for general laboratory use or as a sensitive visual null detector for bridge measurements. For an aural indication of the null point the amplifier can be used with head telephones. It may also be used as a pre-amplifier for crystal microphones, vibration pickups and cathode-ray oscilloscopes. With a suitable crystal detector it can be used as a sensitive indicator for amplitude-modulated high-frequency voltages (for example, as a standing-wave indicator for a slotted measuring line).

DESCRIPTION: The instrument consists of a high-gain amplifier with an output stage that can be operated as a linear amplifier for general laboratory use or as a logarithmic amplifier for null-detector use. The panel meter indicates the amplifier output in two ranges, serves as a null indicator, and is also used to check the condition of the battery. The null-detector response is approximately logarithmic over a 40-db range. A 30-db input attenuator is provided for attenuation of high input voltages. Either a BA18 battery pack or the TYPE 1261-A Power Supply can be placed within the cabinet to operate the instrument, but over-all performance is somewhat better with the battery. Blocking capac-

itors at both input and output jacks isolate the instrument from direct current in the external circuits to which it may be connected. A filter jack on the panel of the instrument permits insertion of an anti-resonant filter, such as the TYPE 1231-P, in the grid circuit of the last stage for modifying the frequency characteristic.

FEATURES: ► Plainly labelled push button controls make the operation of the amplifier simple and convenient.

► Input and output terminals are arranged to take either TYPE 274 Plugs or TYPE 774 Coaxial Connectors.

► The self-contained meter makes the instrument a very convenient detector for bridge measurements.

► Harmonics or noise outside the operating frequency range are easily and effectively eliminated by the insertion of filter units.

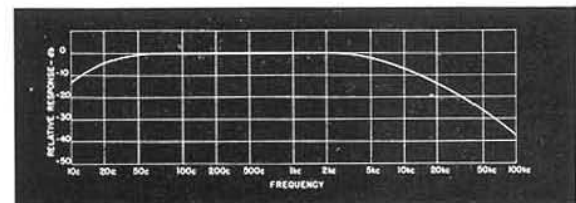

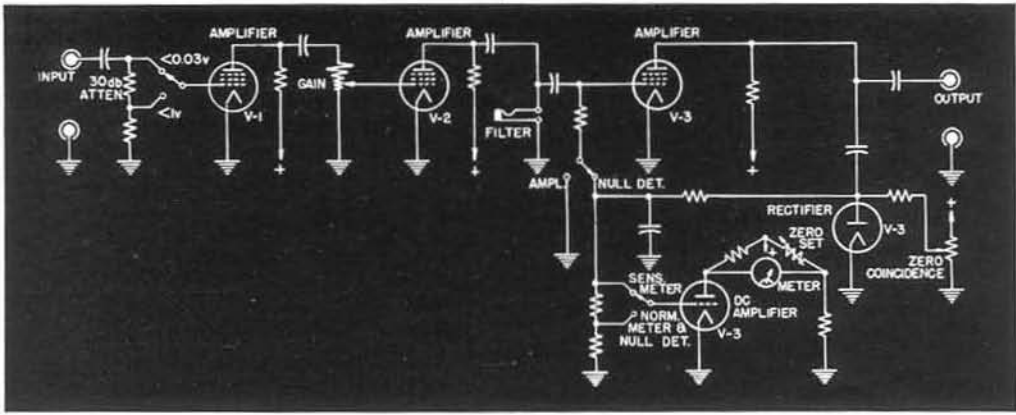

SPECIFICATIONS

Input Impedance: 1 megohm in parallel with 20 micro-microfarads.

Maximum Gain: Greater than 83 db at 1 kc with 1 megohm load.

Meter Scales: NORM scale: This scale is the one normally used to monitor the amplifier output voltage. It is calibrated approximately in volts with an accuracy of reading of $\pm 5\%$ of full scale.

SENS scale: This scale is used for determining ratios of voltages successively applied to the input terminals, as in standing-wave measurements. It is calibrated approximately in decibels with an arbitrary zero. Thus a ratio expressed in decibels is obtained by subtracting one meter reading from another. Ratios so obtained are accurate within 30% of the correct value in decibels, provided at least one of the readings is above half scale on the meter.

No separate scale is provided for NULL DET operation, since actual readings are not needed.

Null Detector Sensitivity: Less than 100 microvolts input is required to give 10% indication on the meter at 1 kc.

Amplifier Sensitivity: Less than 25 microvolts input at 1 kc is required to give 10% indication on SENS range of the meter.

Output Impedance: Approximately 50,000 ohms.

Maximum Output Voltage: 5 volts into 20,000 ohms; 20 volts into 1 megohm.

Noise and Hum Level: The open circuit noise level is less than 0.5 volt at full gain. When the TYPE 1261-A Power Supply is used, the open circuit noise and hum level is less than 1 volt.

Frequency Response: See curve on preceding page.

Tubes: The instrument requires two TYPE 1L4 and one TYPE 1D8-GT Tubes, which are supplied in the instrument.

Power Supply: Burgess 6TA60 (Signal Corps BA48) Battery Pack is supplied in place in the instrument. When a-c supply is desired, the TYPE 1261-A Power Supply (see next page) can be used.

Battery Life: Between 200 and 250 hours at 8 hours per day.

Accessories Available: TYPE 1231-P2 (400 and 1000 cycles) and TYPE 1231-P3 (60 cycles) Tuned Circuits are available for providing selectivity (see below). For facilitating connections to the input and output, two TYPE 274-M Plugs are supplied. TYPE 274-NC or TYPE 274-NE Shielded Connectors may be used. Where complete shielding is required, TYPE 774 Coaxial Connectors (page 204) are recommended.

Dimensions: 12 1/4 x 8 x 10 3/4 inches, over-all.

Net Weight: 23 3/4 pounds, including batteries.

| Type | | Code Word | Price |
|--------|-----------------------------|-----------|----------|
| 1231-B | Amplifier and Null Detector | VALID | \$195.00 |

TYPE 1231-P TUNED CIRCUITS



USES: These tuned-circuit filters are primarily designed for use with the TYPE 1231-B Amplifier and Null Detector for suppressing harmonics, noise, and hum in single-frequency measurements, such as the balancing of a bridge.

DESCRIPTION: The TYPE 1231-P Tuned Circuits are parallel resonant circuits. The 400- and 1000-cycle circuits are mounted in the same case, and a toggle switch is installed for selecting the desired frequency. A plug and a length of shielded cable are furnished with all units.

FEATURES: ► Harmonics as well as noise and other components outside the pass band are conveniently eliminated from the detector circuit of a bridge.

► Amplifier gain is not sacrificed appreciably because the insertion loss of the filters is



POWER SUPPLIES

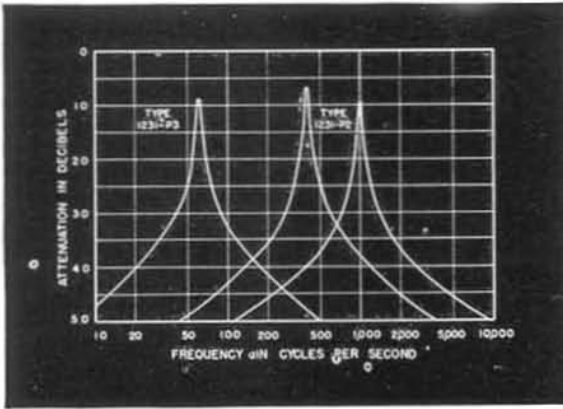

Attenuation characteristics of TYPE 1231-P Tuned Circuits.

small and can usually be tolerated for most uses because of the high gain of the amplifier.

► The frequency characteristic of the TYPE 1231-B Amplifier and Null Detector when the TYPE 1231-P Tuned Circuits are used with it is independent of the terminating impedances ordinarily encountered.

SPECIFICATIONS

Frequency: Two units are listed, one for 60 cycles and the other for both 400 and 1000 cycles. The accuracy of tuning is $\pm 2\%$. Units for other frequencies can be made on special order.

Attenuation: See accompanying curves. Note that the TYPE 1231-P2 is effective in removing 60-cycle hum as well as harmonics of the resonant frequency.

Mounting: Standard drawn-steel case, Model C (see page 140 for dimensions). A plug and 24 inches of shielded cable are provided for connecting to the TYPE 1231-B Amplifier and Null Detector.

Net Weight: $3\frac{1}{8}$ pounds, both models.

| Type | Frequency | Code Word | Price |
|---------|---------------------------|-----------|---------|
| 1231-P2 | 400 and 1000 cycles | AMBLE | \$20.00 |
| 1231-P3 | 60 cycles | AMPLE | 15.00 |

TYPE 1261-A POWER SUPPLY

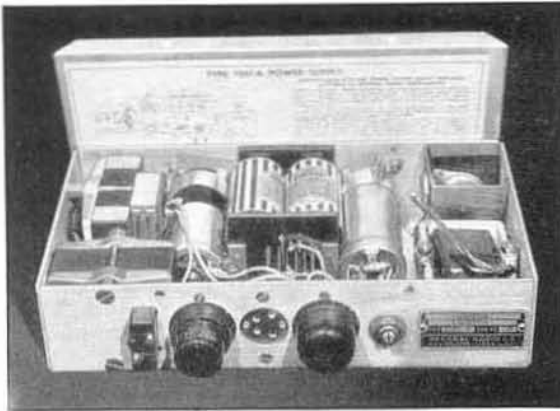

USES: The TYPE 1261-A Power Supply is an a-c power pack for use in place of batteries in battery-operated instruments where continuous operation, such as production testing, makes it desirable to operate the instrument from an a-c power line. The power pack is designed to be the equivalent of a BA48 (Burgess 6TA60) combination battery in voltages, current capacity, size and shape, so that it is interchangeable electrically and mechanically with that battery. It can be used in the following General Radio instruments:

TYPE 720-A Heterodyne Frequency Meter
 TYPE 759-A or -B Sound-Level Meter
 TYPE 1231-A or -B Amplifier and Null Detector

DESCRIPTION: This power supply is a light compact unit that fits into the battery compartment of General Radio instruments which use the BA48 battery block.

A selenium rectifier and L-C filter with two flashlight cells floating across the output provide a low-impedance well-filtered and regulated d-c filament supply. A conventional vacuum-tube rectifier and R-C filter provide the plate supply. A four-terminal output socket fits the plug on the battery cable of instruments which use the BA48 battery.

Octal Selector Plugs inserted into a socket on the top of the power supply make it possible to select filament and plate voltages for various needs.

FEATURES: ► Filtering action equivalent to that of a large capacitor is obtained by floating two flashlight cells across the output filament supply.

► Essentially constant filament voltage is maintained by means of these small batteries. When the power supply is in operation, normal line voltage variations cause the cells either to charge slightly or deliver small amounts of power to the load.

► The filament output voltage can be set at any time and checked against the battery voltage.

► The life of the flashlight cells is practically equal to their shelf life. A small relay, built

as part of one of the filter chokes, opens the circuit when the instrument is turned off, so that the cells will not run down.

► Quick interchangeability with the BA48 battery block is possible. No rewiring or circuit changes are required in new instru-

ments purchased with the TYPE 1261-A Power Supply, or purchased since the power supply has become available. Older instruments may require a minor change in the wiring of the battery cable, and full instructions are furnished for such cases.

SPECIFICATIONS

OUTPUT:

Filament Supply: 1.5 volts or 3.0 volts; maximum current 350 ma. Normal current needed through filter choke to operate relay is 300 ma. A bleeder resistor is needed in the selector plug if the load current is less than this value.

Plate Supply: When the power supply is operated from a 115-volt 60-cycle line and the normal filament current of 300 ma is drawn, the plate supply has the following characteristics:

- 133 volts open circuit
- 107 volts at 3 ma
- 89 volts at 5 ma
- 72 volts at 7 ma
- Maximum output current 8 ma

Selector Plugs: One of the following is furnished. Please specify type wanted.

Selector Plug 1261-P1 — Provides proper voltages for TYPE 759-A Sound-Level Meter. Battery Plate of Sound-Level Meter must be replaced by four-terminal plug to fit output socket of TYPE 1261-A Power Supply. Full sensitivity of instrument cannot be used. Attenuator settings below 50 db on B and C weighting networks and below 40 db on the A weighting network are not recommended.

Selector Plug 1261-P2 — Provides proper voltages for TYPE 759-B Sound-Level Meter.

Selector Plug 1261-P3 — Provides proper voltages for TYPE 720-A Heterodyne Frequency Meter.

Selector Plug 1261-P4 — Provides proper voltages for TYPE 1231-A or -B Amplifier and Null Detector. On Null Detector use, the plate supply regulation causes the meter to overshoot somewhat upon rapidly approaching a null.

Selector Plug 1261-P5 — To be wired by customer to meet his own requirements.

Hum and Noise Level — Sufficiently low to assure satisfactory operation of instruments listed under conditions specified.

Input Voltage: 105-125 (or 210-250) volts, 40 to 60 cycles.

Input Power: Approximately 10 watts.

Tube: One 6H6 is used, and is supplied with the instrument.

Batteries: Two Burgess No. 2 uni-cells which are floated across the output of the Filament Supply are furnished.

Accessories Supplied: Line connector cord with ON-OFF switch.

Terminals: A four-terminal output socket fits the plug on the battery cable of the TYPE 759-B, TYPE 720-A, and TYPE 1231-A or -B.

Dimensions: (Length) 10 x (width) 2¼ x (depth) 5 inches.

Net Weight: 7¼ pounds.

| Type | Code Word | Price |
|-----------------------------|-----------|---------|
| 1261-A Power Supply | NUTTY | \$95.00 |

When ordering, specify type of selector plug desired and type number and serial number of instrument with which power supply is to be used. Extra selector plugs can be supplied at a price of \$8.75 each.

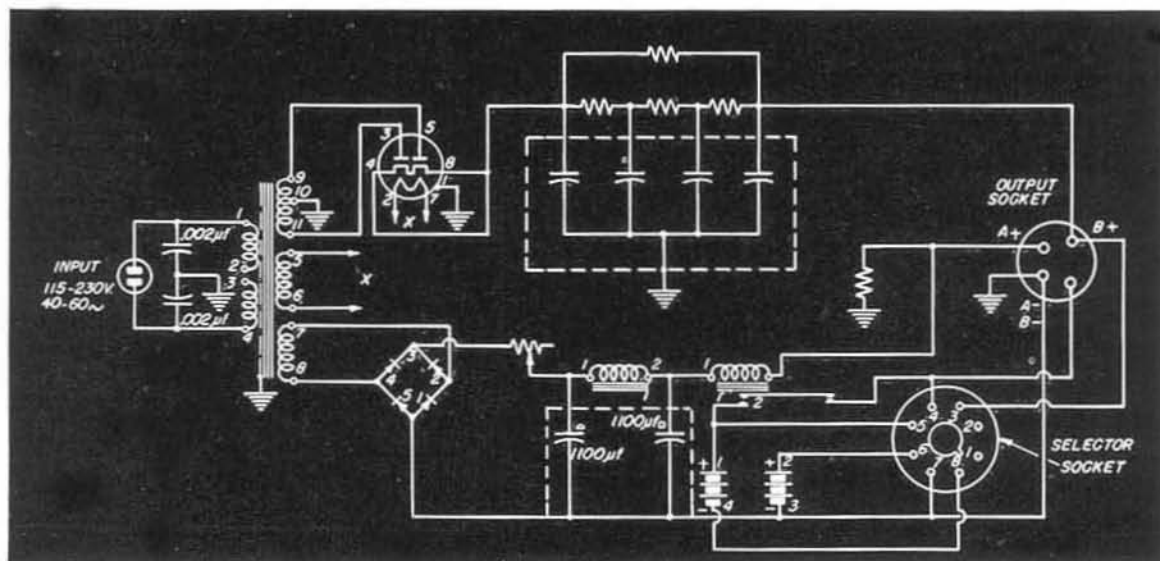

POWER SUPPLIES

TYPE 1260-A VARIAC-RECTIFIER

0-10 VOLTS, 4 AMPERES, DC

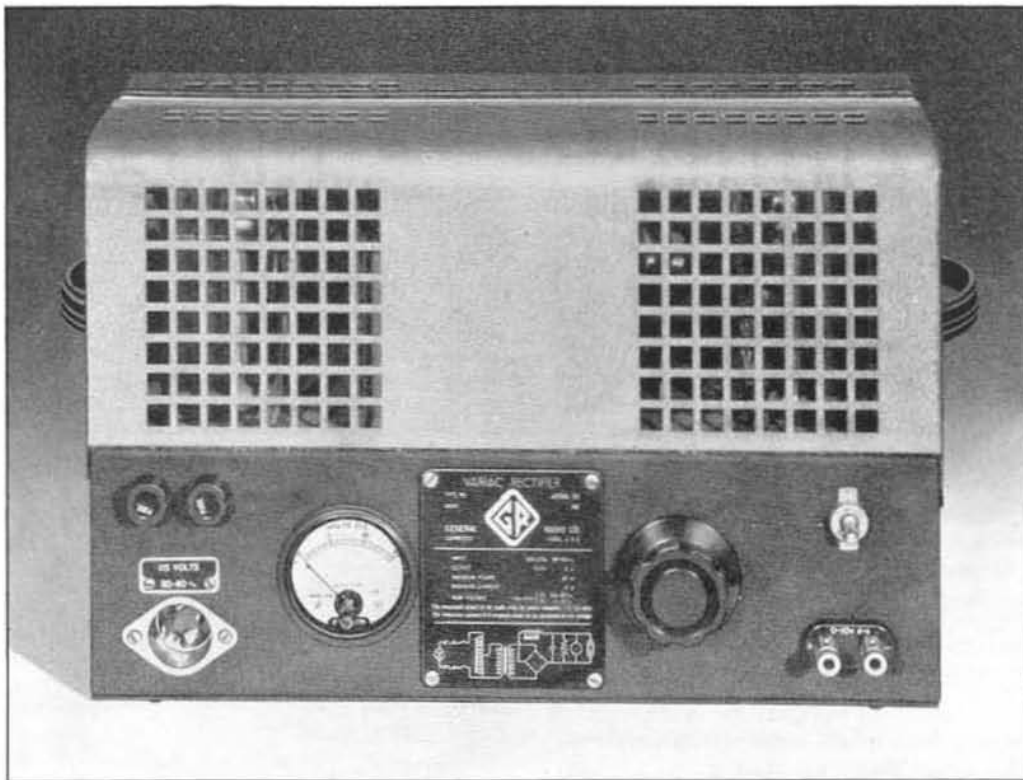

USES: TYPE 1260-A Variac-Rectifier is intended for general laboratory use as a dependable substitute for storage batteries. It is a convenient source of filament and bias voltages for vacuum tubes in experimental circuits.

DESCRIPTION: The elements of the power supply unit are a transformer, a selenium

rectifier and an output filter. The output voltage is controlled by a Variac feeding the transformer primary, and is indicated by a panel meter.

FEATURES: Ease of voltage control from zero to maximum, low hum level, and low internal resistance are the important features of this power supply.

SPECIFICATIONS

Output Range: 4 amperes at 0-10 volts, dc; maximum power, 40 watts; maximum current, 4 amperes; no load voltage, over 15 volts.

Meter: The output voltage is indicated by a voltmeter mounted on the cabinet. A panel knob controls the output voltage.

Power Supply: The unit will operate from a 105- to 125-volt, 50- to 60-cycle line.

Power Input: When the unit is operating at the full 40-watt load, the power input from the a-c line is about 75 watts.

Internal Resistance: The d-c internal resistance is 0.6 ohm.

Hum Voltage: At 10 volts, 4 amperes, the hum voltage is less than 100 millivolts or 1% of the output voltage when the instrument is operated on a 60-cycle line. At 2 volts, 4 amperes, the hum voltage is less than 60 millivolts or 3% of the output voltage when the instrument is operated on a 50-cycle line. For lower load currents, the hum decreases.

Accessories Supplied: Line connector cable.

Mounting: The instrument is mounted in a metal cabinet suitable for table use.

Dimensions: (Length) 16 x (depth) 7 x (height) 9½ inches, over-all.

Net Weight: 26¾ pounds.

| Type | Code Word | Price |
|-------------------------------|-----------|----------|
| 1260-A Variac-Rectifier | VALET | \$125.00 |



These unit instruments are flexible, inexpensive devices for general laboratory use. The three units listed are designed to be assembled in combination as required for a particular application. They are especially useful in the school or college laboratory both

for teaching and for use in experimental work by students. They provide, at low cost, indispensable laboratory instruments — a wide-frequency-range power source and an amplifier capable of delivering three watts.



(Left) TYPE 1206-A Unit Amplifier, and (Right) TYPE 1207-A Unit Oscillator connected to the TYPE 1205-A Unit Power Supply.

TYPE 1205-A UNIT POWER SUPPLY

This power pack is designed primarily for use with the TYPE 1206-A Unit Amplifier and the TYPE 1207-A Unit Oscillator. Connections to the oscillator or amplifier are made through multipoint connectors mounted in the ends of the instruments. When so assembled, the combination of units is very compact, occupying a minimum of bench space. The power supply can also be used separately as a general-purpose source of heater and plate power for other electronic equipment.

Output Voltages: 6.3 volts, ac, at 2.5 amperes, maximum, 300 volts, dc, at 50 milliamperes maximum. No-load voltage is about 390 volts. No regulation is provided.
Hum Level: 0.8 volt at 300 volts and 50 milliamperes.
Input Power Supply: 115 (or 230) volts, 50 to 60 cycles.
Input Power: Approximately 12 watts, no load; approximately 50 watts, full load.
Rectifier Tube: One 6X5-GT/G which is supplied.
Output Terminals: A standard multipoint connector is arranged for plugging directly into either the TYPE 1206-A Unit Amplifier or the TYPE 1207-A Unit Oscillator. A mating plug is provided for use with other equipment, and a line connector cord is supplied.
Dimensions: (Width) 5 $\frac{3}{8}$ x (height) 5 $\frac{3}{8}$ x (depth) 5 $\frac{3}{8}$ inches over-all. **Net Weight:** 6 $\frac{3}{4}$ lbs.

| Type | Code Word | Price |
|---------------------------------|-----------|------------------|
| 1205-A Unit Power Supply..... | APPLY | Price on Request |

TYPE 1206-A UNIT AMPLIFIER

USES: This amplifier is designed for maximum utility in the laboratory. Its maximum gain is sufficient for use in the detector circuits of impedance bridges, while its output power is adequate for driving many low-power laboratory devices. The normal operating range covers both audio and supersonic frequencies.

DESCRIPTION: The amplifier circuit contains two triode voltage-amplifier stages and an impedance-coupled output stage. Cathode degeneration is employed on the input stage, and additional degeneration is included between the second amplifier and the output tube. Power supply connections plug directly into the TYPE 1205-A Unit Power Supply.

FEATURES: ▶ A voltage gain of 45 db combined with a maximum output of 3 watts.
 ▶ Wide frequency range — flat up to 100 kc.
 ▶ Excellent gain stability, low distortion, and good phase-shift characteristic, resulting from the use of inverse feedback.

▶ Wire-wound volume control insures low noise level as gain is changed.

SPECIFICATIONS

Voltage Gain: Continuously adjustable from 0 to 45 decibels.

Load Impedance: 7500 ohms optimum. Blocking capacitor is 1 μ f.

Maximum Output: 3 watts into 7500 ohms can be obtained with less than 5% distortion.

Input Impedance: The input resistance is 200,000 ohms. Blocking capacitor is 0.05 μ f.

Frequency Response: Essentially constant from 100 cycles to 100 kc. Response drops 6 db per octave above 200 kc. Response at 20 c is down 6 db.

Distortion: The distortion when delivering 1 watt into a load of 7500 ohms is less than 2% at frequencies above 100 cycles. At lower frequencies the distortion increases, but is less than 3% at 50 cycles. At an output of 3 watts, total distortion is under 5% above 100 cycles.

A-C Hum: The 60-cycle hum level in the output is about 125 millivolts.

Power Supply: The TYPE 1205-A Unit Power Supply plugs directly into the amplifier.

UNIT INSTRUMENTS

Tubes: One 6SN7-GT and one 6V6-GT are supplied.
Terminals: Jack-top binding posts on 3/4-inch spacing.

Dimensions: (Width) 10 1/4 x (height) 5 7/8 x (depth) 6 1/2 inches over-all. **Net Weight:** 8 3/4 pounds.

| Type | Code Word | Price |
|------------------------------|-----------|------------------|
| 1206-A Unit Amplifier..... | ARBOR | Price on Request |

TYPE 1207-A UNIT OSCILLATOR

USES: The ability of this oscillator to produce a test signal at frequencies ranging from 400 cycles to 80 megacycles makes it a most useful instrument in the laboratory. It fills the need for a simple wide-range power source for measurement and testing, without expensive refinements, but quickly adaptable to a wide variety of uses.

DESCRIPTION: A conventional Hartley circuit is used in this oscillator. Seven plug-in coils are available, which collectively cover a continuous frequency range from 70 kc to 80 Mc. Plug-in coil forms are available and can be used to meet special requirements. Three plug-in circuits are available to operate at fixed frequencies of 400, 1000, and 20,000 cycles, respectively. Jacks across the tuned circuit permit extending the range of any coil by plugging in external capacitors or inductors.

The output circuit is coupled inductively to the tank circuit and the output is adjustable by means of a voltage divider. The assembly plugs directly into the TYPE 1205-A Unit Power Supply.

FEATURES: ▶ Designed for versatility in operation and in application.

- ▶ Controllable output up to 1/2 watt maximum.
- ▶ Very wide frequency range.
- ▶ Good frequency stability through the use of high-Q coils.
- ▶ Jacks facilitate connecting external capacitors and inductors, to obtain any specific frequency within the range from 100 cycles to 100 Mc.

SPECIFICATIONS

Frequency Range: Seven plug-in coils are available to cover the range from 70 kc to 80 Mc, and a plug-in coil form, also available, may be wound to meet special re-

quirements. Three plug-in units are listed to provide within ±2% fixed audio frequencies at 400, 1000, and 20,000 cycles. Coils, coil forms, and plug-in units must be ordered separately (see price list).

Frequency Control: With the seven tunable coils, continuous frequency adjustment is provided by a variable air capacitor, having a uniform scale from 0 to 100.

The audio frequency units are inductor-capacitor combinations, and the internal variable air capacitor has little effect on the frequency. The frequency can be changed, however, by connecting a suitable capacitor or inductor to the jacks provided.

Frequency Stability: The frequency stability is adequate for most laboratory applications, except those involving highly selective tuned circuits. Variations of load impedance cause some shift in frequency.

Output Impedance: Approximately 75 ohms at full output for the coils (70 kc to 80 Mc) and 750 ohms for the tuning units (400, 1000, and 20,000 cycles). A 2000-ohm voltage divider at the output terminals provides an output control.

Output Power: At least a half watt into a matched load up to 5 Mc, and 10 milliwatts at 80 Mc.

Modulation: Jacks are provided for connecting a modulating audio source in series with oscillator plate supply. The oscillator can be amplitude modulated to 50% from 0.5 to 15 Mc. The maximum modulating frequency is 10 kc over this carrier range. The modulating audio oscillator must be capable of delivering about 115 volts to yield 50% modulation.

Terminals: Jack-top binding posts with standard 3/4-inch spacing are provided for the output connection.

Power Supply: The TYPE 1205-A Unit Power Supply plugs directly into the oscillator.

Tube: One 6C4 is used and is supplied.

Accessories Supplied: One extra plug-in coil form; multipoint connector.

Accessories Available: Tuning units, coils, and coil storage rack are listed in price list below.

Dimensions: 1207-A: (Width) 10 x (height) 5 7/8 x (depth) 6 3/8 inches over-all.

P1, P2, and P3: 4 1/4 x 2 1/2 x 3 inches each over-all.

P4, P5, P6, P7, P8, P9, and P10: 2 3/8 inches diameter x 3 1/2 inches over-all.

Net Weight: Coils: 5 oz. each; Tuning Units: (P1, 1 3/4 lbs) (P2, 1 1/4 lbs) (P3, 1 1/2 lbs.); 1207-A: 5 1/4 lbs.

| Type | Code Word | Price |
|---------------------------------------|------------|---------------------------------|
| 1207-A Unit Oscillator..... | ARGON | Prices on Request |
| 1207-P1 Tuning Unit, 400 c..... | ARGONSAWAY | |
| 1207-P2 Tuning Unit, 1 kc..... | ARGONSAFIT | |
| 1207-P3 Tuning Unit, 20 kc..... | ARGONSAPIS | |
| 1207-P4 Coil, 70 kc to 180 kc..... | ARGONSALOE | |
| 1207-P5 Coil, 180 kc to 500 kc..... | ARGONSABLE | |
| 1207-P6 Coil, 0.5 Mc to 1.5 Mc..... | ARGONSACRE | |
| 1207-P7 Coil, 1.5 Mc to 5 Mc..... | ARGONSANTY | |
| 1207-P8 Coil, 5 Mc to 15 Mc..... | ARGONSARTY | |
| 1207-P9 Coil, 15 Mc to 50 Mc..... | ARGONSAQUA | |
| 1207-P10 Coil, 50 Mc to 80 Mc..... | ARGONSAYAH | |
| 1207-P11 Coil form with case..... | ARGONSAXLE | |
| 1207-P12 Coil Storage Rack..... | ARGONSASHY | |



OSCILLATORS



AND STANDARD SIGNAL GENERATORS

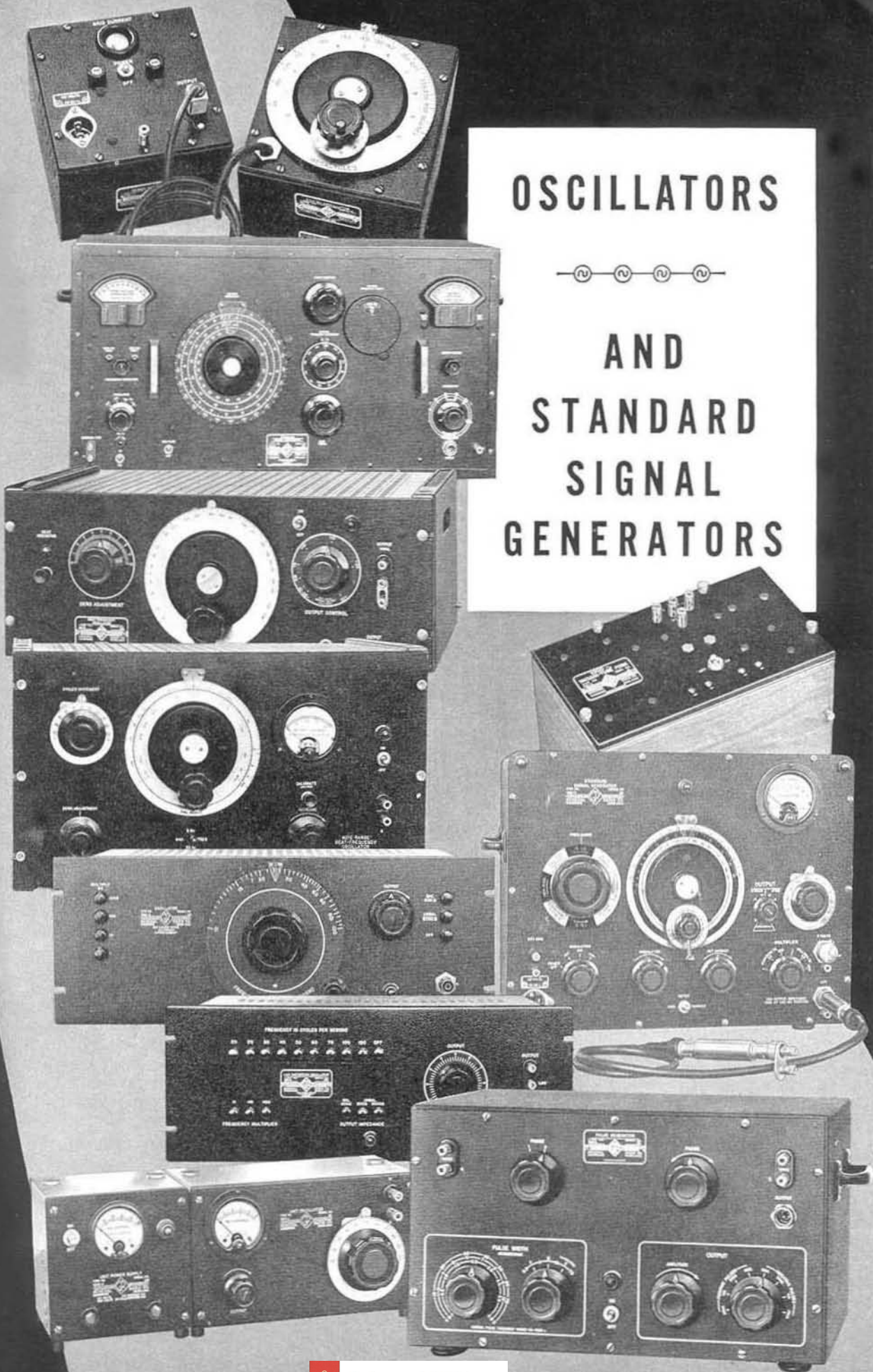

OSCILLATORS AND GENERATORS

In electronics and electrical communications laboratories, few instruments are as essential as oscillators. A source of power or test voltage is a prerequisite to nearly all types of measurements — impedance, transmission, waveform, sensitivity, and many others. Since 1919 the General Radio Company has been supplying laboratory oscillators for this purpose and has always pioneered in new designs and new circuits.

Functionally, oscillators can be grouped under the following classifications:

(1) Resonant-circuit (L-C) types — where the frequency of oscillation is determined by a tuned circuit having inductive and capacitive elements.

(2) Beat-frequency types — where the output frequency is the difference between the frequencies of two oscillators, one variable and one fixed. This type permits a wide frequency range to be covered with a single control.

(3) R-C types (degenerative) — where the frequency is determined by a filter circuit composed of resistive and capacitive elements and the circuit is highly degenerated except at the pass frequency. This type of oscillator also covers a wide frequency range with a single control, and alternatively can be designed to produce a number of fixed frequencies, as selected by a switch. Excellent waveform can be obtained from the R-C degenerative oscillator at low power levels.

(4) Electro-mechanical types — where the frequency is determined by a vibrating mechanical system.

Oscillators are often designed for specific applications, so that emphasis in the design must be given to a single characteristic, such as high output power, pure waveform, frequency stability, or wide frequency range. While any one of these characteristics, or in many cases, two, can be achieved, it is not, in general, economical to combine all four in a single instrument.

The General Radio Company manufactures all of the functional types listed above, and the characteristics of available models are tabulated in convenient form on the next page.

The tuned-L-C oscillator is little used now for audio-frequency measurement and testing, because of the relatively expensive array of inductors and capacitors necessary if a wide range of frequency is to be covered. For audio-frequencies, it has been superseded

by beat-frequency and R-C types. At radio-frequencies, however, where tuning can be accomplished by air capacitors, the L-C circuit remains the best and most economical frequency-determining system. General Radio standard-signal generators use tuned-circuit oscillators to cover frequency ranges as large as 10,000:1. The TYPE 857-A UHF Oscillator is a tuned-circuit instrument using the butterfly circuit as the tuning element.

The first commercial beat-frequency oscillator was produced by General Radio in the middle 1920's. As the development of tubes and circuits has progressed, increasingly better models have been developed, culminating in the present TYPE 913-C.

The R-C degenerative type is a General Radio development, covered by a basic patent, under which other manufacturers have been licensed. Two models are offered, the TYPE 1301-A, whose primary characteristic is low distortion, and the TYPE 1302-A designed for a wide frequency range. The former finds its greatest use as a test tone source for distortion measurements, and the latter as a power source for bridge measurements.

The General Radio Company manufactures a number of electro-mechanical oscillators. Quartz-crystal-controlled types, for use as frequency standards, are listed in the FREQUENCY section of this catalog, as are two low-frequency tuning-fork types. Listed in the following section are two audio-frequency tuning-fork models, the TYPE 813 and the TYPE 723. These are useful as low-power sources for continuous operation, as in modulating beacon transmitters. A microphone hummer, the TYPE 572-B, uses a tuned reed as the frequency stabilizing element, and is a convenient, low-priced device for building into bridges and other equipment.

The first commercial standard signal generator was produced by the General Radio Company in 1927. Improved designs have been offered every few years since that time. At present, two types are listed, the TYPE 805-C, suitable for use as a laboratory standard, and the new TYPE 1001-A, a versatile, lower-priced instrument. Both are amplitude modulated.

The pulse generator, while nominally listed in the OSCILLATOR section of the catalog, is primarily a wave-shaping device, requiring excitation from an external audio oscillator.



OSCILLATORS

| Type No. | Name | Class | Frequency Range | Maximum Output | Open-Circuit volts | Output Impedance | Harmonic Distortion | Power Supply | See Page Number |
|----------|--------------------------------------|--------------------|---|---|--------------------|---|---------------------|-----------------------|-----------------|
| 913-C | Beat-Frequency Oscillator | Beat-Frequency | 20-20,000 cycles | 0.3 watt | 25 | 600 ohms, balanced or unbalanced | 0.25% 1% | A-C Line | 114 |
| 700-A | Wide-Range Beat-Frequency Oscillator | Beat-Frequency | 50 cycles to 40 kc 10 kc to 5 Mc | 0.15 watt | 10-15 | 1500 ohms, unbalanced | < 3% | A-C Line | 116 |
| 1301-A | Low-Distortion Oscillator | R-C Degenerative | 20-15,000 cps (27 fixed frequencies) | 18 milliwatts 100 milliwatts | 6.6 30 | 600 ohms, balanced or unbalanced 5000 ohms, unbalanced | 0.1% | A-C Line | 118 |
| 1302-A | Oscillator | R-C Degenerative | 10-100,000 cycles | 40 milliwatts 20 milliwatts 80 milliwatts | 10 5 20 | 600 ohms, balanced 300 ohms, unbalanced 5000 ohms, unbalanced | 1% | A-C Line | 120 |
| 857-A | U-H-F Oscillator | Tuned Circuit | 100-500 Mc | 0.5 watt | | Coaxial Line | | A-C Line | 122 |
| 723 | Vacuum-Tube Fork | Electro-Mechanical | 400, 440, or 1000 cycles, (3 models) | 50 milliwatts | 31 max. | 50, 500, 5000 ohms | 0.5% | A-C Line or Batteries | 126 |
| 813-A | Audio-Oscillator | Electro-Mechanical | 1000 cycles | 30 milliwatts | 24 max. | 50, 500, 5000 ohms | 1% | Batteries | 127 |
| 572-B | Microphone Hummer | Electro-Mechanical | 1000 cycles, $\pm 10\%$ | 15 milliwatts | 4.2 max. | 10, 300 ohms | | Batteries | 128 |

STANDARD-SIGNAL GENERATORS

| Type No. | Name | Modulation | Frequency Range | Output Volts | Output Impedance | Power Supply | See Page Number |
|----------|---------------------------|---|-----------------|---|----------------------------|--------------|-----------------|
| 805-C | Standard-Signal Generator | A-M, 0-100%: internal, 400 and 1000 cycles; external, 50-15,000 cycles. | 16 kc to 50 Mc | 0.1 microvolt to 2.0 volts | 37.5, 7.1 and 0.75 ohms | A-C Line | 110 |
| 1001-A | Standard-Signal Generator | A-M, 0-80%: internal 400 cycles; external, 20-15,000 cycles. | 5 kc to 50 Mc | 0.1 microvolt to 0.2 volts; 2.0 volts | 10, 50, and 500 ohms | A-C Line | 112 |



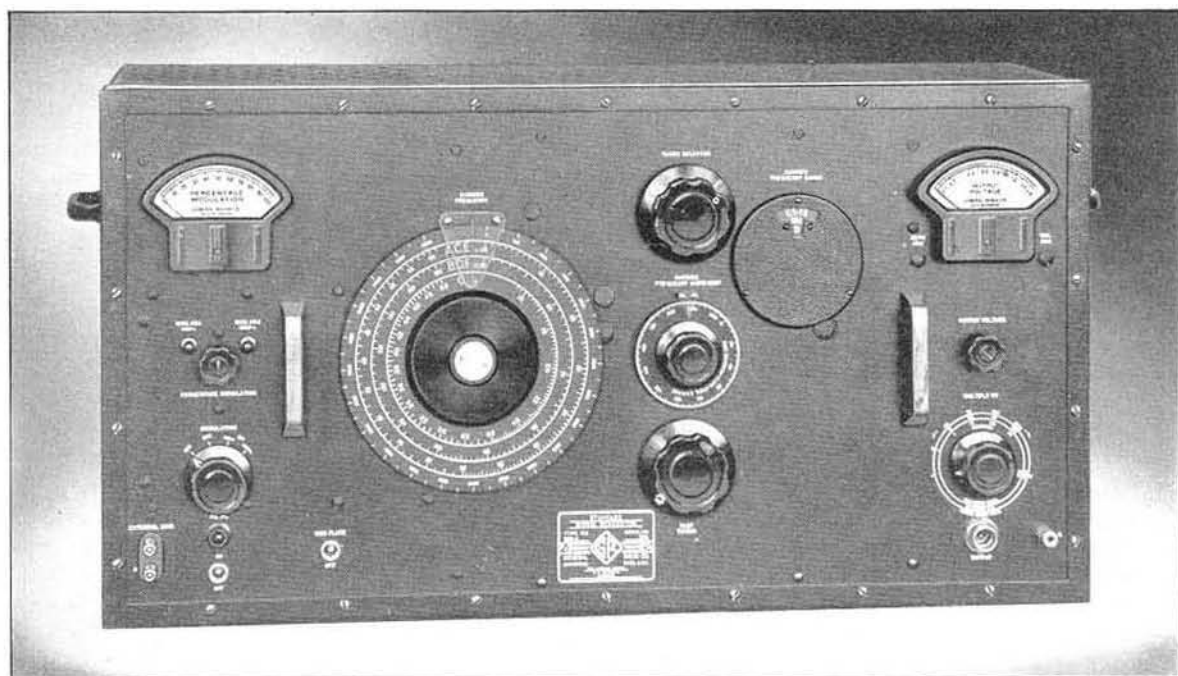

TYPE 805-C STANDARD-SIGNAL GENERATOR

USES: The TYPE 805-C Standard-Signal Generator is designed primarily as a precision laboratory instrument for rapid and accurate testing of radio receivers. Because of its accuracy, wide frequency range, and high voltage output, it is a valuable instrument for laboratories engaged in research and design on radio receivers and allied apparatus, while its speed and simplicity of operation make it well adapted to production testing.

DESCRIPTION: Functionally this instrument consists of (1) a carrier-frequency oscillator, (2) a tuned radio-frequency amplifier, (3) a resistive output attenuator and a voltmeter to read the output level, (4) a modulating oscillator (400 cycles and 1000 cycles) with a voltmeter for reading percentage modulation, and (5) a well-regulated power supply.

The oscillator and amplifier assemblies are virtually identical in construction, and the coil switching assemblies, as well as the tuning capacitors, are ganged and driven from common panel controls. Seven coils covering the frequency range from 16 kc to 50 Mc are carried on a selector disc in each assembly. An eighth coil position is also provided, so that an extra set of coils may be installed if desired. The discs are driven from a panel knob through a gear mechanism, which also brings into panel view a frequency range identification dial. As each coil is rotated into position, it is connected into circuit through silver-overlaid contact blades, which firmly engage silver alloy brushes, mounted on the tuning capacitor. The contacts are mounted on

polystyrene strips, insuring both low capacitance and low dielectric losses.

The main tuning capacitors are exceptionally rugged, utilizing the cast frame type of construction, with ball-bearing supports for the rotor. The plates are shaped to give a logarithmic variation of frequency with angular rotation. The two capacitors are driven through a set of gears, which also drive the direct-reading frequency dial.

The output system consists of a vacuum-tube voltmeter, a resistive attenuator network, a 3-foot, 75-ohm output cable, and a terminating unit. This unit terminates the cable in its characteristic impedance. It provides, in addition to the normal output at 37.5 ohms, outputs reduced by factors of 10 and 100, with corresponding output impedances of 7.1 and 0.75 ohms. A standard dummy antenna output is also provided.

FEATURES: ▶ Signals of accurately known intensity are provided at the end of a properly terminated low-impedance cable. Thus the voltage is known at the point of application and the necessity for computing lead effects is eliminated.

▶ Radio-frequency leakage and stray fields are reduced by careful filtering and shielding to such an extent that measurements can be made at levels as low as 0.5 microvolt.

▶ Reaction of the output circuit on the carrier frequency is lessened by use of a tuned amplifier stage. Sideband cutting is kept at a minimum by heavy damping of the tuned plate circuit.

SIGNAL GENERATORS

- ▶ A precision of setting of 0.01% is obtained by the use of a gear-reduction vernier drive. Backlash in the gear trains is kept to a minimum by automatic take-up springs.
- ▶ The effect of ordinary line-voltage fluctu-

ations over the range from 105 to 125 (or 210 to 250) volts is eliminated by electronic stabilizer circuits in the plate power supply and a ballast tube in the filament supply of the vacuum-tube voltmeters.

SPECIFICATIONS

Carrier Frequency Range: 16 kilocycles to 50 megacycles, covered in seven direct-reading ranges, as follows: 16 to 50 kc, 50 to 160 kc, 160 to 500 kc, 0.5 to 1.6 Mc, 1.6 to 5.0 Mc, 5.0 to 16 Mc, 16 to 50 Mc. A spare range position is provided so that a special set of coils can be installed if desired.

Frequency Calibration: Each range is direct reading to an accuracy of $\pm 1\%$ of the indicated frequency.

Frequency Drift: Not greater than $\pm 0.05\%$ on any frequency range for a period of 5 hours' continuous operation.

Incremental Frequency Dial: A slow-motion vernier drive dial is provided, by means of which frequency increments as small as 0.01% may be obtained.

Output Voltage Range: Continuously adjustable from 0.1 microvolt to 2 volts. The output voltage (at the termination of the 75-ohm output cable) is indicated by a panel meter and seven-point multiplier.

Output System: The output impedance at the panel jack is 75 ohms, resistive. A 75-ohm output cable is provided, together with a termination unit that furnishes constant output impedances of 37.5, 7.1, and 0.75 ohms. The calibration of the panel voltmeter-multiplier combination is in terms of the actual voltage across the 37.5-ohm output. When the 7.1- and 0.75-ohm positions are used, the indicated output voltage must be divided by 10 and 100, respectively. A standard dummy-antenna output is also available at the termination unit.

Output Voltage Accuracy: For multiplier settings below 1 volt the maximum error in output voltage is the sum of the attenuator and voltmeter errors listed below.

Maximum Voltmeter Error: $\pm 5\%$ up to 25 megacycles. Above 25 megacycles, an additional frequency error occurs, amounting to $\pm 7\%$ at 50 megacycles. At 1/10 full scale and 50 Mc, there is also a transit-time error of -5% in the voltmeter tube.

Maximum Attenuator Error:

- Below 3 Mc, $\pm(3\% + 0.1 \text{ microvolt})$
- 3 to 10 Mc, $\pm(5\% + 0.2 \text{ microvolt})$
- 10 to 30 Mc, $\pm(10\% + 0.4 \text{ microvolt})$
- 30 to 50 Mc, $\pm(15\% + 0.8 \text{ microvolt})$

There is no attenuator error for the 1-volt multiplier setting.

Modulation: Continuously variable from 0 to 100%. The percentage of modulation is indicated by a panel meter to an accuracy of $\pm 10\%$ of the meter reading up

to 80%, for carrier frequencies below 16 Mc; $\pm 15\%$ for higher carrier frequencies.

Internal modulation is available at 400 cycles and 1000 cycles, accurate in frequency within $\pm 5\%$.

The generator can be modulated by an external oscillator. Approximately 10 volts across 500,000 ohms are required for 80% modulation. The over-all modulation characteristic is as follows:

| Carrier Frequency | Audio Range | Level |
|-------------------|------------------------------|----------------------|
| 0.5—50 Mc | 50~—15,000~ | $\pm 1 \text{ db}$ |
| 0.1—0.5 Mc | 50~—10,000~ | $\pm 1.5 \text{ db}$ |
| 16—100 kc | 50~—10% of Carrier Frequency | $\pm 1.5 \text{ db}$ |

Frequency Modulation: On the highest carrier frequency range the frequency modulation is about 0.05% for 100% modulation, and 0.02% for 30% modulation. At lower carrier frequencies the frequency modulation is less than these percentages.

Distortion and Noise Level: The envelope distortion at a modulation level of 80% is less than 4% at 1 Mc carrier frequency. Carrier noise level is at least 40 db below 80% modulation.

Leakage: The magnetic induction leakage is less than 5 microvolts per meter at a distance of 2 feet from the generator. The 3-foot output cable permits the receiver under test to be kept beyond this limit. Radiation fields are negligible.

Power Supply: The instrument operates from any 40 to 60 cycle, 115-volt (or 230-volt) line. An electronic voltage regulator compensates for line voltage fluctuations from 105 to 125 volts (or from 210 to 250 volts). A maximum input power of 140 watts is required.

Tubes: Supplied with instrument:

| | |
|---------|----------------|
| 1—6C8-G | 1—0D3/VR150 |
| 3—6L6 | 1—955 |
| 1—5T4 | 1—6H16 |
| 2—2A3 | 1—Amperite 3-4 |
| 1—6SF5 | |

Accessories Supplied: Seven-foot line connector cord, and shielded output cable and termination unit.

Mounting: The panel is finished in black crackle and the cabinet is black wrinkle finish.

Dimensions: (Height) 16 x (width) 33 x (depth) 12 inches, over-all.

Net Weight: 117½ pounds.

| Type | Code Word | Price |
|---|-----------|-----------|
| 805-C Standard-Signal Generator | LEPER | \$1350.00 |

PATENT NOTICE. See Note 1, page vi.

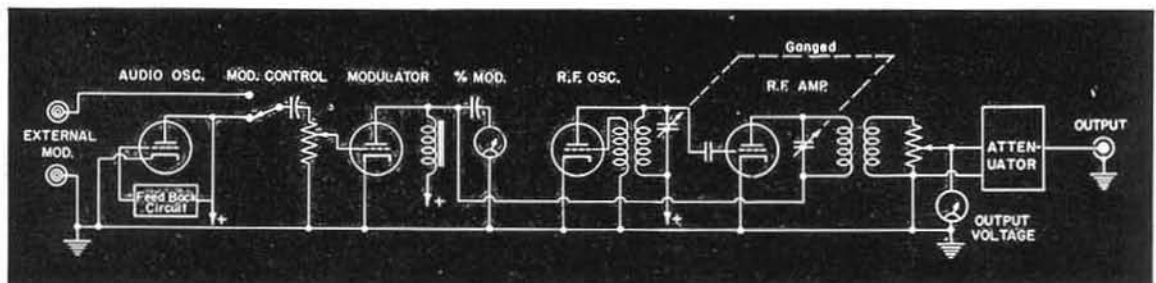

TYPE 1001-A STANDARD-SIGNAL GENERATOR

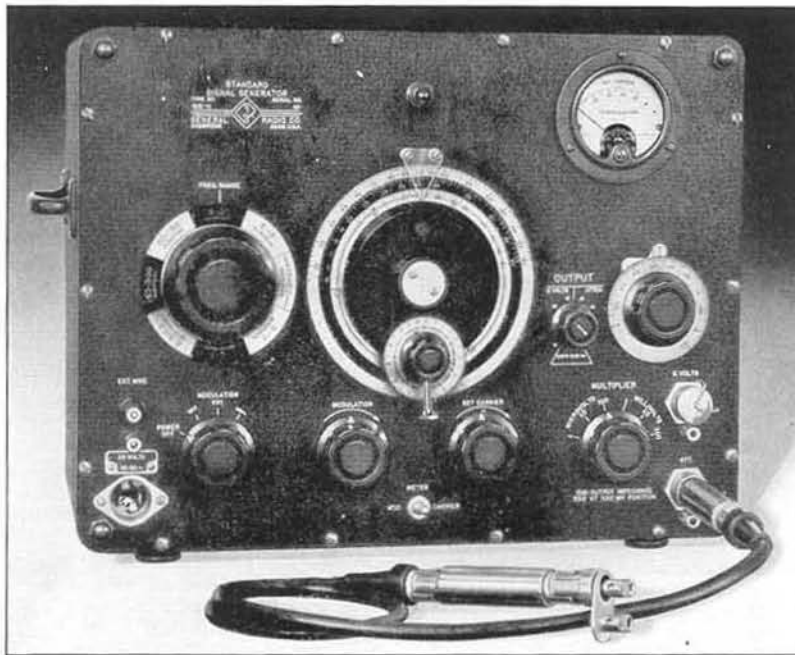

USES: The TYPE 1001-A Standard-Signal Generator is a laboratory instrument for use in determining the performance of receivers and other equipment at radio and supersonic frequencies. Its sturdy construction and simplicity of operation make it also well adapted for production testing. Because of its small size, low weight, and low power consumption, it can be adapted for portable use in field strength measurements. Among other applications is its use as a power source for bridges and other measuring circuits where complete shielding and a wide frequency range are required.

DESCRIPTION: The welded aluminum cabinet of the TYPE 1001-A Standard-Signal Generator houses three separate groups of circuits. The power supply is at the top, the completely shielded radio-frequency portion in the middle, and the modulation and control circuits at the bottom.

The carrier-frequency oscillator uses a Hartley circuit and covers in eight ranges the frequency spectrum from 5 kc to 50 Mc. The plates of the main tuning capacitor are shaped to give a logarithmic variation of frequency with angular rotation. The precision of frequency setting, therefore, is constant, and the vernier dial is calibrated directly in percentage frequency increments.

A buffer amplifier is used between the oscillator and the low-impedance output circuits. The amplifier is grid modulated to provide amplitude modulation from 0 to 80

percent. Loose coupling between the oscillator and the amplifier minimizes incidental frequency modulation. The attenuator system and the output meter are coupled to the amplifier through a high-pass filter, which eliminates voltages of modulation frequency from the output.

The output voltage is determined by establishing a fixed carrier level at the attenuator input and by setting two attenuator controls. The carrier level is set by adjusting the plate supply voltage of the oscillator and is indicated by a vacuum-tube voltmeter at the attenuator input. The attenuator system consists of a continuously adjustable L-network controlled by the output dial and a six position decade ladder-network attenuator.

The modulation circuits include a 400-cycle R-C oscillator for internal modulation and a germanium crystal rectifier to determine modulation percentage. Percentage modulation is read on the same panel meter that indicates the carrier output level.

FEATURES: ▶ The TYPE 1001-A Standard-Signal Generator provides accurately known output voltages at two output jacks on the front panel, which are convenient for use at low frequencies, or at the end of a terminated cable for higher accuracy at high frequencies. The termination resistor can be removed for matching into a 50-ohm system.

▶ Residual output voltage and leakage are so low that accurate measurements can be made on even the most sensitive receivers.

- ▶ The use of an aperiodic amplifier as a buffer and modulator practically eliminates side-band cutting and reaction of attenuator setting or of load on carrier frequency.
- ▶ High stability and low drift are assured by the use of ceramic coil forms and tuning capacitor insulators, and by the low power

- consumption of the complete instrument.
- ▶ All critical power-supply voltages are regulated.
- ▶ Simplicity of design and construction has resulted in an unusually sturdy instrument of small size and weight, which should give trouble-free operation for a long time.

SPECIFICATIONS

Carrier-Frequency Range: 5 kilocycles to 50 megacycles covered in eight direct-reading ranges as follows: 5 to 15 kc, 15 to 50 kc, 50 to 150 kc, 150 to 500 kc, 0.5 to 1.5 Mc, 1.5 to 5 Mc, 5 to 15 Mc, and 15 to 50 Mc.

Frequency Calibration: The accuracy of calibration is ± 1 percent. The dial calibration is logarithmic up to 15 Mc, but departs slightly from the logarithmic scale at higher frequencies.

Incremental-Frequency Dial: The slow-motion vernier-drive dial is calibrated to indicate increments of 0.1 percent of frequency per division up to 15 Mc.

Output Voltage Range: The open-circuit output voltage at the attenuator jack is continuously adjustable from 0.1 microvolt to 200 millivolts. For use at high frequencies, a 3-foot, 50-ohm concentric cable and terminating resistor to match its characteristic impedance are supplied. When the cable is terminated at both ends, the output voltage is continuously adjustable from 0.05 microvolt to 100 millivolts. The open-circuit output voltage at the 2 VOLTS panel jack is measured directly by the output meter and is 2 volts if the meter is set to the reference mark. This voltage is available up to at least 15 Mc.

Output Impedance:* The output impedance at the attenuator jack is 10 ohms (50 ohms when the series unit is used) except for the highest output position of the attenuator, where it is 50 ohms.

The output impedance at the end of the terminated cable is 25 ohms. The output impedance at the 2 VOLTS panel jack is about 300 ohms.

An output impedance of one ohm (with output voltage reduced 100:1) can be obtained by using the TYPE 1001-P3 Voltage Divider, not supplied with the instrument, but listed separately below.

An output impedance equivalent to that of the Dummy Antenna specified in the I.R.E. Standards can be obtained by using the TYPE 1001-P4 Standard Dummy Antenna, not supplied with the instrument, but listed separately.

A known induction field for testing loop receivers can be obtained with the TYPE 1001-P10 Test Loop, not supplied with the instrument, but listed separately below.

Accuracy of Output Voltages: The absolute accuracy of the open-circuit output voltage at the attenuator jack is determined by the accuracy of the output meter and of the decade attenuator. In addition, it varies with both the output dial setting and the carrier frequency. At frequencies below 10 Mc, when the output dial is set at about full scale or at about one-tenth full scale, the output voltage is correctly indicated to $\pm (6\% + 0.1 \mu\text{v})$. With the output dial set in the mid-scale region, the error may be greater or smaller by 4%. At frequencies above 10 Mc, when the output dial is set at about full

scale, the output voltage is correctly indicated to an accuracy of $\pm (10\% + 0.3 \mu\text{v})$ and the error may be as much as 10% larger or smaller at other output dial settings.

The accuracy of the open-circuit output voltage at the 2 VOLTS panel jack is $\pm 3\%$ up to 15 megacycles.

Amplitude Modulation: Adjustable from zero to 80%. Modulation percentage is indicated on the panel meter and is accurate within $\pm 10\%$ of the indicated value.

The internal modulation frequency is 400 cycles per second $\pm 5\%$.

The external modulation characteristic is flat within ± 1 decibel from 20 cycles to 15 kilocycles. To provide 80% modulation, the external audio oscillator must supply 12 volts into a 4000-ohm load (36 milliwatts).

Incidental Frequency Modulation: At 80% amplitude modulation, the incidental frequency modulation varies from about 10 to 100 parts per million over each carrier-frequency range except for the highest frequency range (15-50 Mc) where it may be three times as great.

Envelope Distortion: About 6% at 80% amplitude modulation.

Noise Level: Carrier Noise Level corresponds to about 0.1% modulation.

Leakage: Stray fields are substantially less than one microvolt per meter two feet from the generator.

Terminals: TYPE 874 coaxial terminals are provided for the attenuator output and for the constant 2-volt output.

Power Supply: 105 to 125 (or 210 to 250) volts, 40 to 60 cycles. Power input is approximately 65 watts.

Tubes: Supplied with the instrument.

| | |
|----------|---------------|
| 1 — 6C4 | 1 — 5Y3-GT |
| 1 — 6L6 | 2 — 0C3/YR105 |
| 1 — 6AL5 | 1 — 6SN7-GT |

Accessories Supplied: TYPE 874-R10 3-foot Coaxial Cable, TYPE 1001-P1 50-ohm Termination Unit, TYPE 1001-P2 40-ohm Series Unit, TYPE 874-Q2 Adaptor, TYPE 1001-215 Adjustment Tool, and a power cord.

Other Accessories Available: Not supplied, but available on order are the TYPE 1001-P3 Voltage Divider, the TYPE 1001-P4 Dummy Antenna, and the TYPE 1001-P10 Test Loop.

Mounting: The instrument is assembled on an aluminum panel finished in black crackle lacquer and mounted in an aluminum cabinet with a black wrinkle finish. The cabinet is provided with carrying handles. A recessed compartment is built into the top of the cabinet for storing the accessories.

Dimensions: (Height) $14\frac{3}{8}$ x (width) $20\frac{1}{4}$ x (depth) $10\frac{3}{8}$ inches over-all.

Net Weight: 52 pounds.

*See "Output Systems of Signal Generators," *General Radio Experimenter*, Volume XXI, Number 1, June, 1946.

| Type | Code Word | Price |
|----------|---------------------------------|----------|
| 1001-A | Standard-Signal Generator | \$535.00 |
| 1001-P3 | 100:1 Voltage Divider | 15.00 |
| 1001-P4 | Dummy Antenna | 15.00 |
| 1001-P10 | Test Loop | 30.00 |

PATENT NOTICE. See Note 1, page vi.





TYPE 913-C BEAT-FREQUENCY OSCILLATOR

USES: This is a general-purpose beat-frequency oscillator that is particularly useful as a power source for tests on audio-frequency lines and associated networks. It is also useful as a voltage source for bridge measurements and for modulating signal generators and test oscillators. The oscillator can be used on either balanced or unbalanced systems.

DESCRIPTION: The TYPE 913-C Beat Frequency Oscillator utilizes the conventional beat-frequency oscillator design, but has a number of unusual design features that contribute to improved performance and ease of operation. Two radio-frequency oscillators, one fixed and one variable, feed a pentagrid converter. The resulting difference frequency, after passing through a low-pass filter, is amplified in a balanced, degenerative amplifier. The output level is controlled by a constant-impedance attenuator that is calibrated in decibels with respect to an output of one milliwatt into a 600-ohm line.

For permanent or relay-rack installation, duplicate output terminals are provided at the rear of the instrument, through standard multipoint connectors.

A neon lamp beat indicator is provided to

assist in standardizing the frequency calibration of the oscillator by setting to zero beat. The frequency dial carries a logarithmic scale, and is driven by a slow-motion gear-reduction drive.

FEATURES: ▶ The output voltage of this oscillator is practically constant over the entire frequency range. Because of this fact and because the output control is calibrated directly in decibels, it is possible to take frequency characteristics directly without a dummy generator resistance and oscillator voltmeter.

▶ A high degree of stability, in output voltage as well as frequency, is obtained by the use of highly stable elements in the oscillator circuits and stabilization of the power supply.

▶ Power-supply hum is reduced to a very low level by careful design of the power-supply filter.

▶ Good waveform is achieved by means of careful oscillator circuit design in conjunction with degeneration in the audio amplifier.

▶ Small size and light weight make the oscillator conveniently portable and contribute greatly to its general utility.

SPECIFICATIONS

Frequency Range: 20 to 20,000 cycles.

Frequency Control: The main control is engraved from 20 to 20,000 cycles per second and has a true logarithmic frequency scale. The total scale length is approximately 12 inches. The effective angle of rotation is 240°, or 80° per decade of frequency.

Frequency Calibration: The calibration can be standardized within 1 cycle at any time by setting the instrument to zero beat. The calibration of the frequency control dial can be relied upon within $\pm(1\% + 0.5 \text{ cycle})$ after the oscillator has been correctly set to zero beat.

Zero Beat Indicator: A neon lamp is used to indicate zero beat.

Frequency Stability: Improved design of the oscillator circuits and the use of highly stable capacitors and inductors result in an unusually high degree of stability. The drift from a cold start is less than 7 cycles in the first hour and is essentially completed within two hours.

Output Impedance: The output impedance is 600 ohms, either grounded or balanced-to-ground, and is essentially constant regardless of the output control setting. With load impedances of 2000 ohms or less, the output is balanced for all settings of the output control. With higher load impedances, unbalance may occur at low settings of the output control.

Output Voltage: Approximately 25 volts open circuit. For a matched resistive load the output voltage varies by less than ± 0.25 db between 20 and 20,000 cycles. The open-circuit output voltage is approximately 40 volts with the output switch in the HIGH position.

Output Control: The output control is calibrated in db referred to 1 milliwatt into 600 ohms. The total range is from +25 to -20 db.

Output Power and Waveform: NORMAL output 0.3 watt maximum when operated into a matched load, with total harmonic content approximately 0.25% between 100 and 7500 cycles. Below 100 cycles the harmonic content increases, and may reach 0.5% at 50 cycles. A panel switch allows an increase in the output power to a maximum of 1 watt. For this HIGH position of the OUTPUT switch the distortion is less than 1% between 100 and 7500 cycles and increases to 2% at 50 cycles. With the OUTPUT control turned fully on, the harmonic content is approximately doubled when the oscillator is operated into a very low impedance. If,

however, the OUTPUT control is turned 3 db or more below the maximum setting, the load impedance has very little effect upon the waveform.

A-C Hum: For NORMAL output the a-c hum is less than 0.1% of the output voltage. Since the volume control is in the output circuit, the hum percentage does not increase for low output voltages. The hum may be slightly greater on the HIGH output range.

Temperature and Humidity Effects: Large changes in ambient temperature and humidity necessitate a readjustment of the zero-beat setting. High temperatures and humidity cause a slight increase in distortion and a slight decrease in output.

Terminals: Jack-top binding posts with standard 3/4-inch spacing and standard Western Electric double output jack are provided on the panel. A standard multipoint socket and plug provide duplicate output terminals on the back of the instrument for relay-rack installation.

Mounting: The panel is designed for mounting on a 19-inch relay rack, but removable wooden ends are supplied so that it may be used equally well on a table.

Power Supply: 105 to 125 volts, 50 to 60 cycles a-c. A simple change in the connections to the power transformer allows the instrument to be used on 210 to 250 volts. The total consumption is about 100 watts.

- Tubes:**
- 3—6SL7-GT
 - 1—6SA7
 - 1—5V4-G
 - 2—6V6-GT
 - 2—0D3/VR150
 - 1—991

All are supplied with the instrument.

Accessories Supplied: A seven-foot line connector cord, and a multipoint connector.

Dimensions: 19 3/8 x 14 1/4 x 7 1/2 inches, over-all.

Net Weight: 41 1/2 pounds.

| Type | Code Word | Price |
|-------|---------------------------|----------|
| 913-C | Beat-Frequency Oscillator | CAROL |
| | | \$450.00 |

PATENT NOTICE. See Notes 1, 25, page vi.

OTHER BEAT-FREQUENCY OSCILLATORS

Other types of beat-frequency oscillators are described on pages 116 and 172. TYPE 700-A (page 116), with an upper frequency limit of 5 Mc, is designed for wide-band measurements. TYPE 1107-A (page 172) has a linear scale from 0 to 5000 cycles, and is used as an interpolation device in frequency measurements.

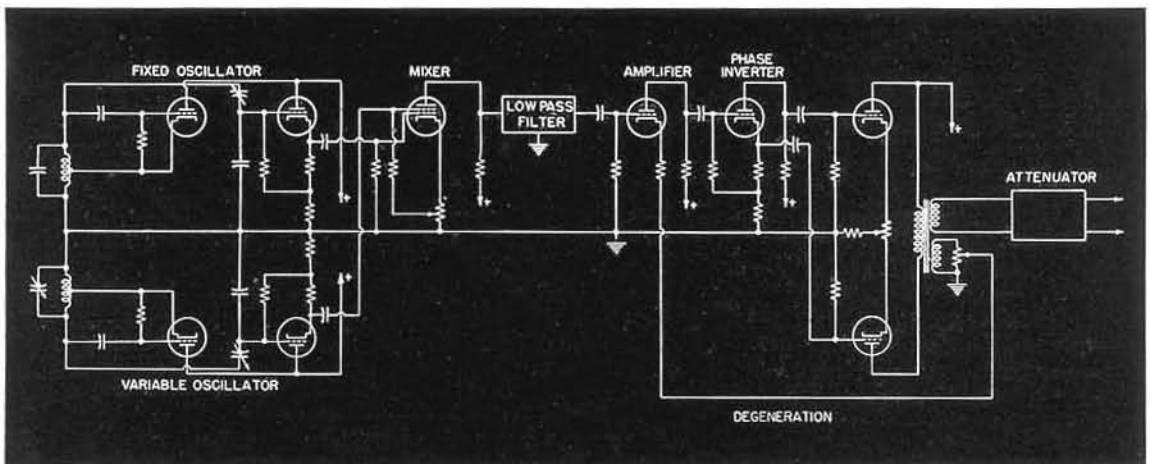

OSCILLATORS

TYPE 700-A WIDE-RANGE BEAT-FREQUENCY OSCILLATOR

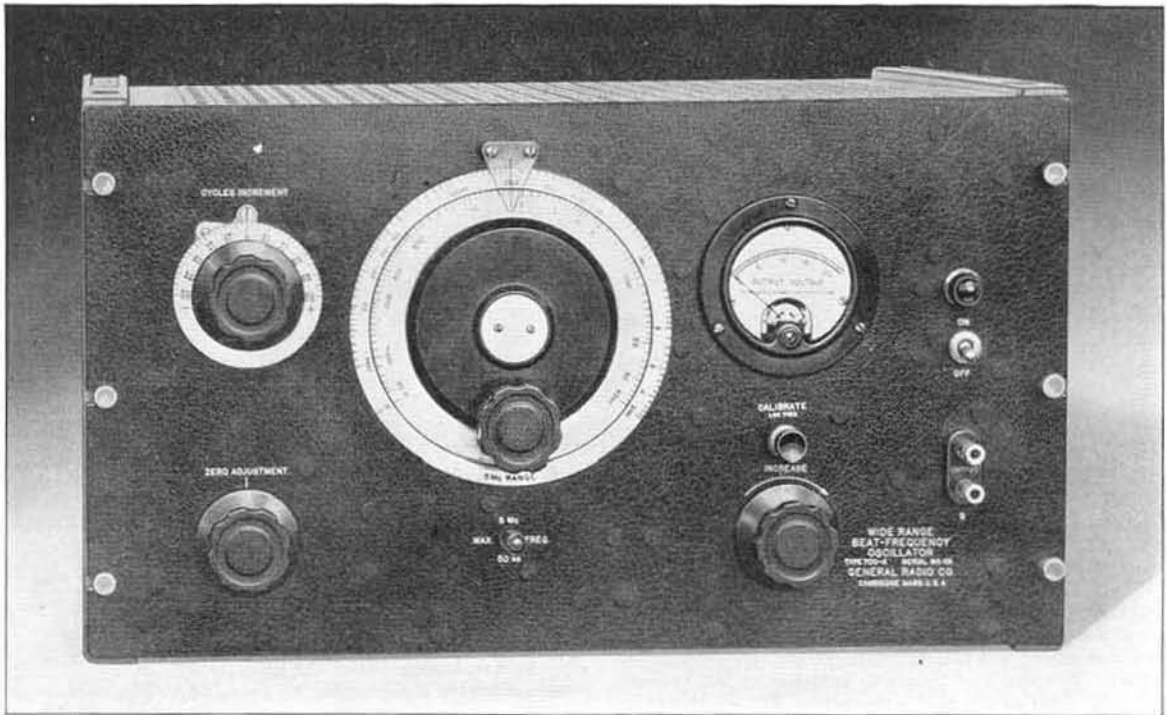

USES: This oscillator is useful for taking selectivity curves over a wide range of frequencies, for measuring the transmission characteristics of filters, and for testing wide-band systems such as television amplifiers and coaxial cables. The instrument is also an excellent general laboratory oscillator for use as a source for bridge measurements and as a modulator for standard-signal generators.

DESCRIPTION: Two high-frequency oscillators, one fixed and the other variable, feed a detector from which the difference frequency is obtained. The detector is followed by a low-pass filter and a two-stage wide-band amplifier.

Both oscillator circuits are mounted in a heavy cast-aluminum box to assure uniform heat distribution and practically perfect shielding. Two ranges are provided for by changing the frequencies of both the oscillators by a factor of one hundred. A single switch on the panel changes from one range to the other.

Degeneration is employed in the amplifier to minimize hum and distortion, and to equalize the frequency response. Low-pass filters are provided to maintain a high ratio of desired output voltage to beating voltage. A pentagrid mixer tube and a buffer amplifier are used to isolate the two oscillators electrically.

FEATURES: ▶ A very wide range of frequencies is covered with a single direct-reading control dial.

▶ The frequency variation with dial setting is approximately logarithmic.

▶ An incremental frequency control, also direct reading, can be used to make small variations in frequency at any point.

▶ A low-frequency range has been incorporated into the oscillator for convenience in working at audio frequencies.

▶ A high degree of output voltage stability is obtained by a delayed automatic volume control circuit, which also helps to eliminate variations caused by line voltage fluctuations.

SPECIFICATIONS

Frequency Range: Two ranges are provided: 50 cycles to 40 kilocycles, and 10 kilocycles to 5 megacycles.

Frequency Control: The main dial is direct reading in frequency and carries two approximately logarithmic frequency scales covering the ranges specified above. A frequency range switch is provided for rapidly changing from one range to the other. There is also an incremental

frequency control which is calibrated between -100 and $+100$ cycles on the low range and -10 and $+10$ kilocycles on the high range. Any frequency change made with this control adds algebraically to the frequency of the main control.

Frequency Calibration: The calibration may be standardized at any time by setting the instrument to zero



beat with the zero adjustment control. This adjustment can be made within 5 cycles on the low range or 500 cycles on the high range.

After the oscillator has been correctly set to zero beat, the calibration of the main frequency-control dial can be relied upon within $\pm(2\% + 5 \text{ cycles})$ on the low range and $\pm(2\% + 800 \text{ cycles})$ on the high range. The calibration of the incremental frequency dial is within ± 5 cycles or ± 500 cycles on the low and high ranges, respectively.

Frequency Stability: Through careful design adequate thermal distribution and ventilation are provided for minimizing frequency drifts. The oscillator can be accurately reset to zero beat at any time, thereby eliminating errors caused by any small remaining frequency drift.

Output Impedance: The output is taken from a 1500-ohm Ayrton-Perry-wound potentiometer. One output terminal is grounded.

Output Voltage: The maximum open-circuit output voltage of the oscillator is between 10 and 15 volts. Because of the automatic volume control circuit, this voltage remains constant within ± 1.5 decibels over each entire frequency range.

Waveform: The total harmonic content of the open-circuit voltage is less than 3% for frequencies above 300 cycles on the low range and above 30 kilocycles on the high range.

A-C Hum: When the oscillator is operated at any supply frequency from 40 to 60 cycles, the power-supply ripple is less than 1% of the output voltage on either range.

Voltmeter: A vacuum-tube voltmeter circuit is used in the oscillator for measuring the output voltage. The indi-

cating meter on the panel is calibrated directly in volts at the output terminals.

Controls: In addition to the main frequency-control dial and the incremental frequency dial, there is a frequency range switch, and a zero beat adjustment. The output voltage is varied by a potentiometer control provided near the output terminals.

Terminals: The output terminals are jack-top binding posts with standard $\frac{3}{4}$ -inch spacing. The lower terminal is grounded to the panel and shields.

Mounting: The instrument is normally supplied for table mounting, but can be easily adapted for relay-rack mounting by removing two walnut frames at the ends of the panel.

Power Supply: A-C power supply, 105 to 125 volts, 40 to 60 cycles, is used. A simple change in the connections to the power transformer allows the instrument to be used on 210 to 250 volts.

The total power consumption is approximately 85 watts.

Tubes: The following tubes are used:

- 2—6J5-GT/G
- 1—6J7
- 1—6L7
- 2—25L6-GT/G
- 1—6H6
- 1—5U4-G
- 1—TYPE 2LAG-949

All tubes are supplied.

Accessories Supplied: A seven-foot power cord, spare TYPE 2LAG-949 neon lamp, and one TYPE 274-ND Shielded Plug.

Dimensions: Panel, (width) 19 x (height) $10\frac{1}{2}$ inches, over-all; depth behind panel, 11 inches.

Net Weight: $57\frac{1}{2}$ pounds.

| Type | Code Word | Price |
|-------|--------------------------------------|----------|
| 700-A | Wide-Range Beat-Frequency Oscillator | ORGAN |
| | | \$700.00 |

PATENT NOTICE. See Note 1, page vi.

TYPE 700-P1 VOLTAGE DIVIDER

The TYPE 700-P1 Voltage Divider extends the readable range of the output voltmeter-potentiometer combination of the TYPE 700 Oscillator down to 100 microvolts. The voltage divider consists of a ladder-type resistive network, mounted in a metal container, which is connected to the oscillator output by means of a shielded plug and cable. Multiplying factors of 0.1, 0.01, 0.001, and 0.0001 can be selected.

Measurements on high-gain, wideband systems are possible because the frequency characteristic of the divider is flat within 10%, for all settings at frequencies up to 5 megacycles.

SPECIFICATIONS

Accuracy: The accuracy of attenuation is $\pm 3\%$.

Impedance: The input impedance is 2000 ohms; the output impedance is 200 ohms.

Dimensions: (Height) $4\frac{1}{2}$ x (diameter) $4\frac{1}{2}$ inches.

Net Weight: $1\frac{1}{2}$ pounds.



| Type | Code Word | Price |
|--------|-----------------|---------|
| 700-P1 | Voltage Divider | OTTER |
| | | \$50.00 |



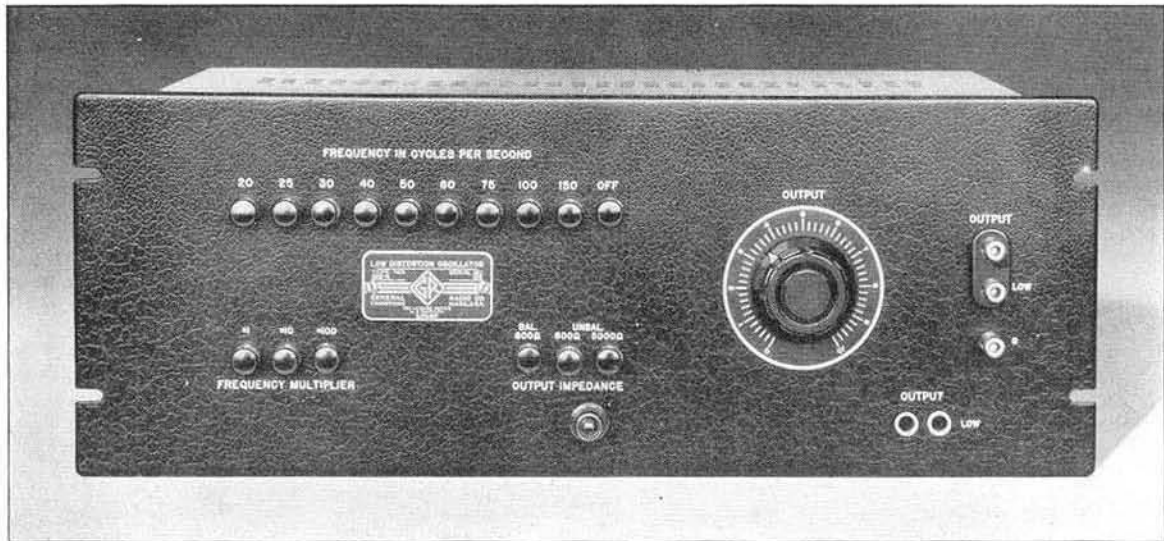

TYPE 1301-A LOW-DISTORTION OSCILLATOR

USES: The TYPE 1301-A Oscillator was designed particularly for use as a tone source for distortion measurements and as a power source for bridge measurements at audio frequencies. Because of the large number of frequencies that can be obtained from this oscillator, it is also satisfactory for measuring frequency characteristics and for use as a general-purpose laboratory oscillator.

The output frequencies include those recommended by the FCC for distortion measurements on broadcast transmitters. This oscillator is thus ideal for use with the TYPE 1932-A Distortion and Noise Meter for rapid distortion measurements.

The unusually pure waveform delivered by this oscillator at low frequencies makes distortion measurements possible at considerably lower frequencies than has hitherto been practicable.

DESCRIPTION: The oscillator is of the resistance-tuned type and operates on the inverse feedback principle developed by the General Radio Company. Separate feedback networks control the frequency and amplitude independently, thus providing high stability and low distortion.

The degenerative feedback which controls the frequency is obtained by means of a parallel-T network including mica capacitors and wire-wound resistors. The regenerative

network includes an automatic control system whereby a high degree of stability is obtained together with low harmonic distortion, without requiring any manual feedback adjustments.

The desired frequency is selected by push-button switches. Another push-button switch selects the output impedance. A control is provided for adjusting the output voltage.

FEATURES: ▶ Low distortion and a high degree of frequency stability are the important features of this instrument.

▶ Instant selection of any one of 27 frequencies from 20 to 15,000 cycles per second can be made by means of the convenient push-button control.

▶ External resistors can be plugged into jacks in the instrument, thus making possible operation at any frequency within the normal operating range. In addition, satisfactory operation can be obtained at frequencies outside of this range and as low as 2 cycles per second, at some sacrifice in purity of waveform.

▶ An external range-extension unit, the TYPE 1301-P1, is available which plugs into the oscillator and provides a multiplying factor of 0.1 for all frequencies. The frequency range is thus extended downward by a full decade to cover from 2 to 15 cycles per second.

SPECIFICATIONS

Frequency Range: 27 fixed frequencies between 20 and 15,000 cycles.

Frequency Control: The frequency is controlled by two push-button switches. The first provides frequencies of 20, 25, 30, 40, 50, 60, 75, 100, and 150 cycles, while the second multiplies these frequencies by 1, 10, and 100. The

frequencies included cover practically the entire audible range in approximately logarithmic increments.

The TYPE 1301-P1 Range Extension Unit is available to provide a multiplying factor of 0.1 (see price list on next page.) This range extension unit plugs directly into jacks provided inside the oscillator.

Frequency Calibration: Each instrument is adjusted within $\pm(1\frac{1}{2}\% + 0.1 \text{ cycle})$.

Frequency Stability: The internal voltage regulator eliminates frequency changes resulting from changes in plate supply. Changes in load have no effect upon the frequency. The frequency drift is not greater than 0.02% per hour after the first 10 minutes of operation.

Output Impedance: Three output circuits are provided. Selection among them is obtained by means of a push-button switch on the panel. The output impedances are as follows:

1. 600-ohm balanced to ground.
2. 600-ohm unbalanced.
3. 5000-ohm unbalanced.

The volume control is a potentiometer in the 5000-ohm circuit. The actual output impedance of the 5000-ohm circuit will vary between 1000 and 6000 ohms, depending upon the setting of the volume control. Suitable resistance pads keep the impedance of the 600-ohm output circuit essentially constant, regardless of the volume control setting. The 600-ohm balanced output circuit is balanced at all frequencies when operating into a balanced load of any impedance.

Output Power: 18 milliwatts into 600-ohm load, or 6.6 volts open circuit; 100 milliwatts into 5000-ohm load, or 30 volts open circuit. The output voltage, for either impedance position, will remain constant within $\pm 1 \text{ db}$ throughout the frequency range.

Waveform Distortion:

5000-ohm output: — Not more than 0.1% between 40-7500 cycles.
 Not more than 0.15% at other frequencies.

600-ohm output: — Not more than 0.1% between 40-7500 cycles.
 Not more than 0.25% between 20-40 cycles.
 Not more than 0.15% above 7500 cycles.

Temperature and Humidity Effects: The operation of the instrument is substantially independent of climatic changes in temperature and humidity. Under extremely high temperature and humidity the two highest frequencies may be affected somewhat during the warm-up period of the instrument.

Power Supply: 105 to 125 (or 210 to 230) volts, 25 to 60 cycles ac. The total power consumption is approximately 45 watts.

Tubes:

- 1—6Y6-G
- 1—6SJ7
- 1—6SK7
- 1—6SQ7
- 1—NE-17
- 1—6X5
- 1—6B4-G
- 1—6SL7-GT
- 1—0D3/VR150

Terminals: Jack-top binding posts with standard $\frac{3}{4}$ -inch spacing and standard Western Electric double output jack are provided on the panel. A ground terminal is also provided. A standard multipoint connector provides duplicate output terminals on the rear of the instrument for relay-rack installation. These terminals are disconnected when a plug is inserted in the Western Electric-type panel jack.

Accessories Supplied: Line connector cord, and multipoint connector.

Mounting: The instrument is relay-rack mounted. Walnut end frames are available to adapt the instrument for table mounting. (See price list below.)

Panel Finishes: Standard General Radio black crackle. Certain standard grays which can be processed in quantity can be supplied at a price increase of \$11.00.

Dimensions: Panel (length) 19 x (height) 7 inches; depth behind panel, 12 inches.

Net Weight: 31 $\frac{1}{2}$ pounds.

| Type | | Code Word | Price |
|-------------|--|------------|------------|
| 1301-A | Low-Distortion Oscillator | OZONE | \$395.00 |
| 1301-P1 | Range Extension Unit (2 to 15 c.p.s.) .. | OVATE | 70.00 |
| ZFRI-412-P1 | End Frames | ENDFRAMDIG | 16.50 Pair |

PATENT NOTICE. See Note 9, page vi.

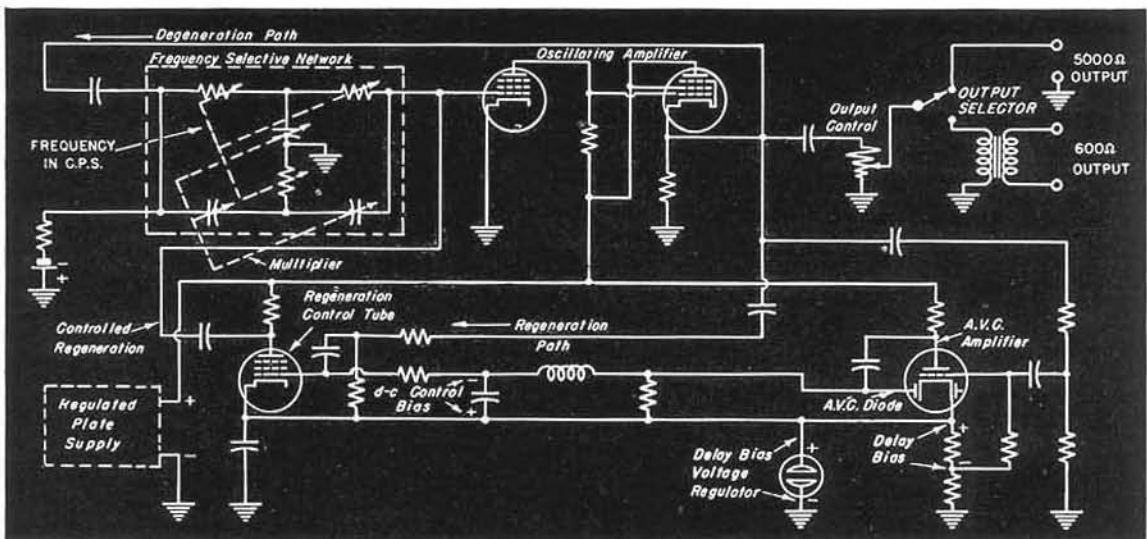

OSCILLATORS

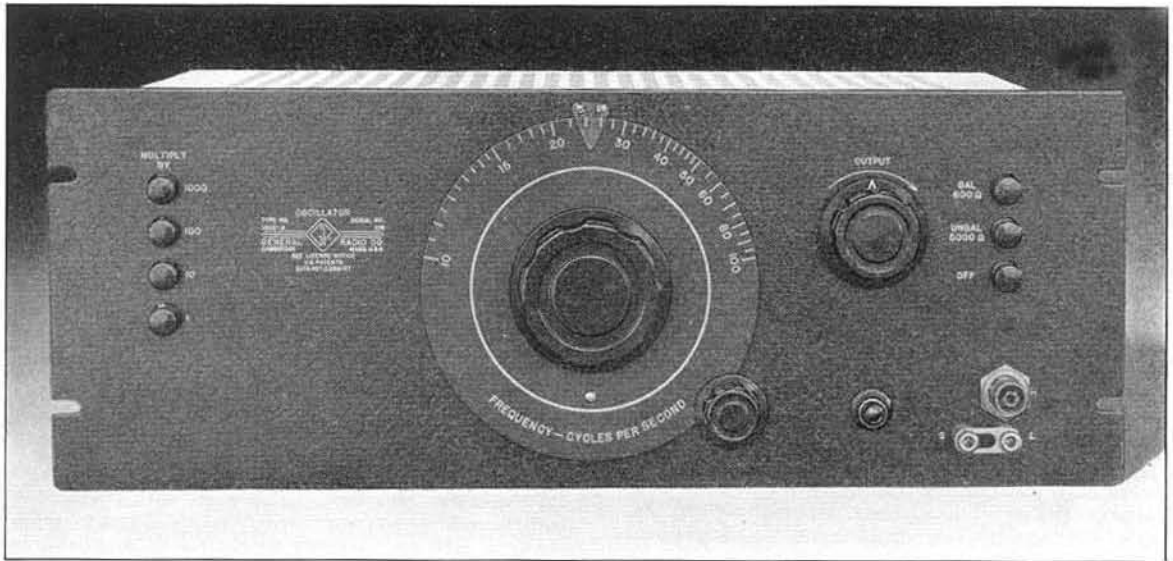

TYPE 1302-A OSCILLATOR

USES: The TYPE 1302-A Oscillator has been designed as a convenient source of power for bridges and other networks especially where the frequency range needed extends beyond the normal limit of audio oscillators into the supersonic range. The entire audio spectrum is covered down to 10 cycles and the upper frequency limit of 100,000 cycles extends far enough into the radio-frequency range to overlap the low end of r-f generators. The oscillator can be used on either balanced or unbalanced systems.

DESCRIPTION: This instrument is a resistance-tuned oscillator employing the inverse feedback principle. The frequency-determining network uses a Wien bridge circuit, in which the capacitive elements are controlled by the main frequency dial, and two resistive elements are selected by a range switch.

The amplitude of oscillation is held constant by using a second bridge section, with a non-linear resistance inserted in one arm of the bridge. A buffer amplifier is inserted ahead of the output level control to minimize reaction on the oscillator frequency.

The output amplifier is arranged to provide balanced-to-ground output for 600-ohm loads as well as unbalanced output for 300- or

5000-ohm loads. The circuit design is such that considerable variations in load values from these nominal outputs can be tolerated without appreciably increasing the distortion. The output terminals are arranged so that a completely shielded coaxial connection can be made.

FEATURES: ▶ The wide frequency range, extending from 10 cycles to 100,000 cycles, is an important feature of the TYPE 1302-A Oscillator.

▶ Excellent frequency stability is obtained by means of the bridge-type feedback circuits.

▶ Harmonic distortion has been kept low.

▶ A semi-logarithmic scale eliminates crowding at the low-frequency end and still allows the high frequencies to be set with the same precision as the low frequencies.

▶ Coaxial shielded output terminals are available for use in bridge measurements and other applications where stray fields are undesirable.

▶ Internal voltage regulation in the power supply removes effects of line-voltage transients and allows the instrument to operate from a wide range of supply voltages.

SPECIFICATIONS

Frequency Range: 10 to 100,000 cycles, in four ranges. Each range covers a decade (10-100 cycles, 100-1000 cycles, 1000-10,000 cycles, and 10,000-100,000 cycles) continuously variable.

Frequency Control: The main control dial is engraved from 10 to 100 cycles over a scale length of approximately 8¾ inches. Four multiplier switches multiply the scale frequencies by 1, 10, 100, or 1000.

Frequency Calibration: Each instrument is adjusted within $\pm(1\frac{1}{2}\% + 0.2 \text{ cycle})$.

Frequency Stability: The warm-up drift is less than 1% in the first ten minutes and is less than 0.2% per hour thereafter.

Output Impedance: Two output circuits are provided, balanced 600 ohms and unbalanced 5000 ohms.

The internal impedance of the 600-ohm output is constant at 550 ohms unless the LOW output terminal is connected to ground by means of the strap provided on the panel. The output impedance is then halved and the output is unbalanced to ground.

The 5000-ohm output position is intended for 5000-ohm loads, unbalanced to ground, although the effective internal impedance of the oscillator averages about 400 ohms in this position.

Output Voltage: Approximately 20 volts open circuit on 5000-ohm output, and 10 volts open circuit on 600-ohm output. The output voltage is constant within $\pm 1.0 \text{ db}$ over the entire frequency range.

Output Power: A maximum power output of 80 milliwatts can be obtained into an unbalanced 5000-ohm load. A maximum of 40 milliwatts can be obtained into a balanced-to-ground 600-ohm load (20 milliwatts into an unbalanced 300-ohm load).

Waveform: Harmonic content is less than 1% for all output values and at all frequencies within its range.

A-C Hum: 5000 Ω output, 24 millivolts, maximum. 600 Ω output, 12 millivolts, maximum.

Terminals: Jack-top binding posts with standard $\frac{3}{4}$ -inch spacing and standard General Radio Type 774 coaxial terminals are provided on the panel. The separate ground terminal has a strap which can be used to ground the LOW output terminal.

Mounting: The instrument is normally supplied for relay-rack mounting, but can be easily adapted for table mounting by the addition of two walnut frames at the ends of the panel (see price list below).

Power Supply: 105 to 125 (or 210 to 250) volts, 50 to 60 cycles.

Total power consumption is about 90 watts.

Tubes: The following tubes are used and are all supplied with the instrument.

- 2—6SL7-GT
- 2—6B4-G
- 1—6AK6
- 1—6F6
- 1—6V6
- 1—6J5
- 1—5V4-G
- 1—0D3/VR150

Accessories Supplied: A line connector cord, coaxial output connector, TYPE 274-M Plug, and multipoint connector.

Dimensions: (Length) 19 $\frac{3}{8}$ x (height) 7 $\frac{1}{2}$ x (depth) 14 $\frac{1}{4}$ inches, over-all.

Net Weight: 30 pounds.

| Type | | Code Word | Price |
|-------------|-----------------|------------|------------|
| 1302-A | Oscillator..... | FINAL | \$365.00 |
| ZFRI-412-P1 | End Frames..... | ENDFRAMDIG | 16.50 Pair |

PATENT NOTICE. See Notes 1, 9, and 25, page vi.

OTHER WIDE-RANGE OSCILLATORS

The TYPE 700-A Wide-Range Beat-Frequency Oscillator, described on page 116, has a frequency range extending from 50 cycles to 5 megacycles.

The TYPE 1207-A Unit Oscillator, described on page 106, is a small and convenient instrument which uses a conventional

Hartley circuit to cover a wide frequency range with several plug-in coils. Three fixed audio frequencies are available in addition to seven continuously tunable ranges which completely cover the range from 70 kilocycles to 80 megacycles.

Schematic circuit diagram of the TYPE 1302-A Oscillator.

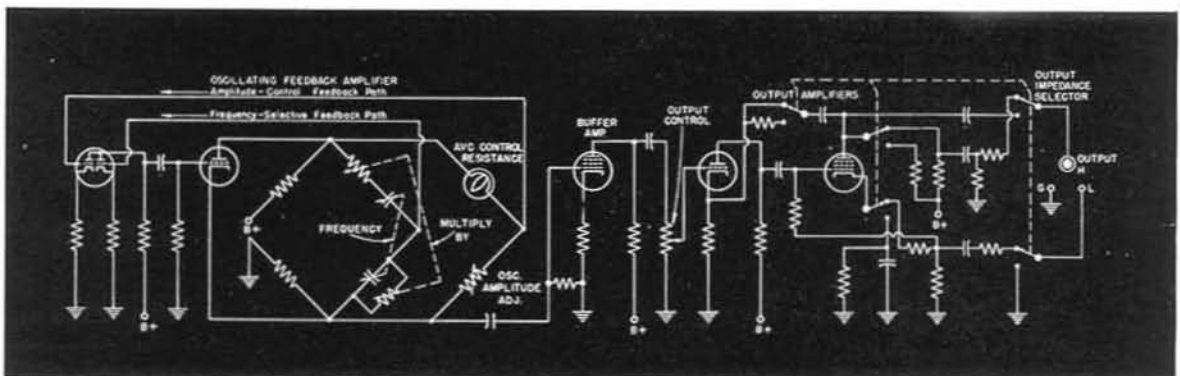

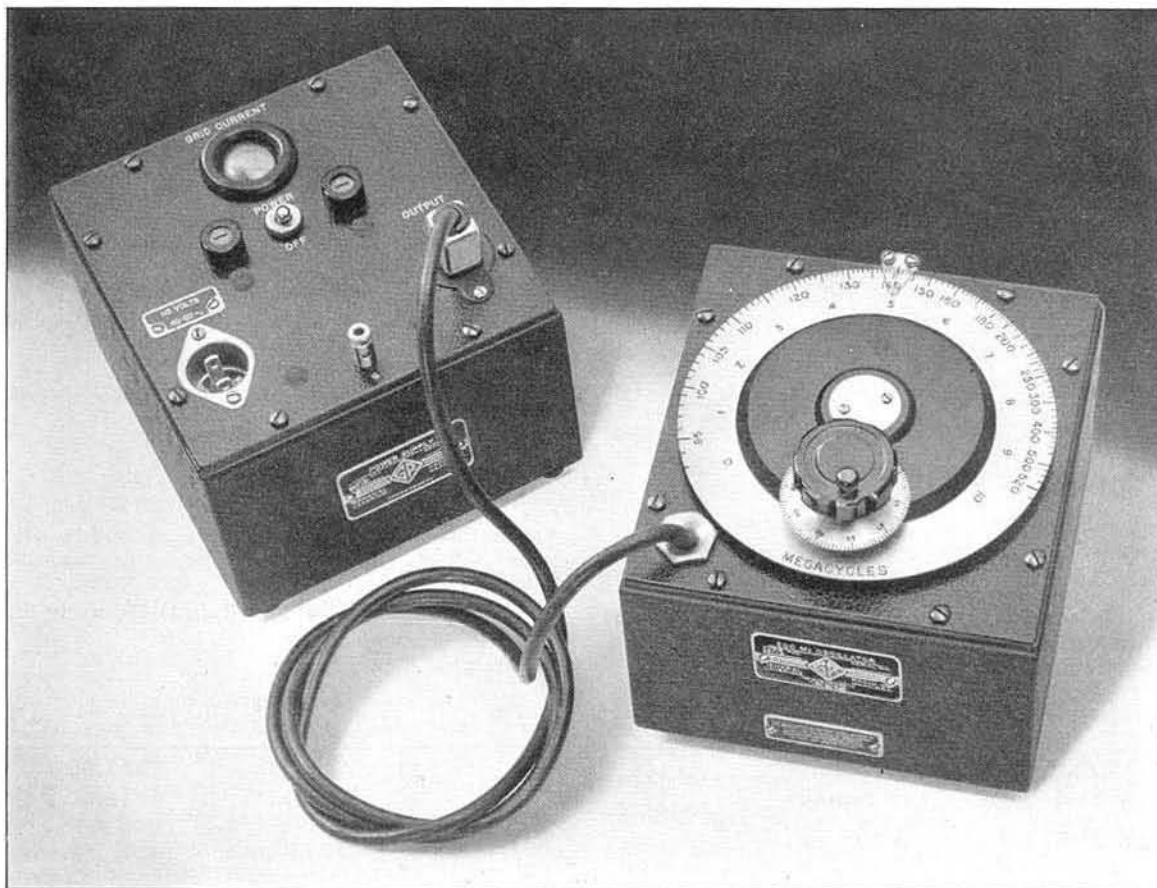

TYPE 857-A U-H-F OSCILLATOR

100 Mc to 500 Mc

USES: The TYPE 857-A U-H-F Oscillator is a power source for measurements and testing in the frequency range between 100 Mc and 500 Mc.

DESCRIPTION: The oscillator consists of a butterfly-type tuned circuit and a W. E. 316-A Vacuum Tube, enclosed in a metal housing that provides a moderate amount of shielding. The a-c power-supply unit is in a separate cabinet.

Output is obtained at a coaxial jack on the side of the cabinet. Output coupling is inductive and can be varied continuously from maximum to practically zero.

The main dial is calibrated directly in megacycles. The vernier dial carries 100 uniform divisions and covers the tuning range in about 10 revolutions. An auxiliary scale indicates revolutions of the slow-motion dial.

Filament and plate power are supplied by

the TYPE 857-P1 Power Supply. A 3-conductor shielded cord of 6-foot length, permanently connected to the oscillator, plugs into the power supply unit.

FEATURES: ▶ A moderate amount of power is delivered by the TYPE 857-A U-H-F Oscillator over a wide frequency range.

▶ Single-dial frequency control, with a slow-motion drive, makes it possible to vary the oscillator frequency in small increments.

▶ Output fluctuations from erratic electrical contact are eliminated by the use of the butterfly circuit as a frequency-determining element, since no electrical connections to the rotor are needed.

▶ Backlash is extremely low, and the insulated rotor shaft is mounted in ball bearings.

▶ The entire assembly is small, compact, and light in weight.

SPECIFICATIONS

Frequency Range: 100 Mc to 500 Mc.

Frequency Calibration: The frequency dial reads directly in megacycles with an accuracy of $\pm 1\%$. Re-

placement of the vacuum tube may cause a shift in the calibration. A trimmer capacitor is provided to compensate for variations in tube capacitance.

Output Power: The oscillator will deliver a maximum of approximately 0.5 watt at the highest frequency. At lower frequencies, the output increases.

Output Coupling: By rotating the output jack, the orientation of the small output coupling loop can be varied from zero to maximum coupling. By screwing the jack in or out, the spacing between the oscillator tuned circuit and the loop can be adjusted in addition. The output terminal is a coaxial plug.

Output Impedance: The output system, with its adjustable coupling, is adapted for use with coaxial lines. Maximum power can be delivered to load impedances in the range normally encountered in coaxial systems.

Power Supply: Filament and plate power is furnished by the TYPE 857-P1 Power Supply, which is mounted in a separate cabinet with connecting cord and plug. The plate voltage supplied by this unit is fixed at the maximum value for safe operation of the tube. It operates from a 105- to 125-volt (or 210- to 250-volt) a-c line, 40 to 60 cycles. The power input is about 60 watts.

Oscillation Indicator: An electron-ray tube is provided in the TYPE 857-P1 Power Supply to indicate grid current and thus furnish an indication of oscillation.

Tubes: 316-A (oscillator); 6E5, 5Y3-GT (power supply). All are supplied.

Accessories Supplied: A line connector cord for power supply and a TYPE 774-M Cable Jack for the coaxial output of the oscillator are supplied.

Mounting: Both oscillator and the power supply unit are mounted in metal cabinets.

Dimensions: Oscillator, $6\frac{1}{8} \times 7\frac{3}{8} \times 7\frac{1}{4}$ inches, over-all; power supply, $5\frac{1}{2} \times 6\frac{3}{8} \times 6\frac{3}{8}$ inches, over-all.

Net Weight: Oscillator, $6\frac{1}{4}$ pounds; power supply, $9\frac{1}{2}$ pounds.

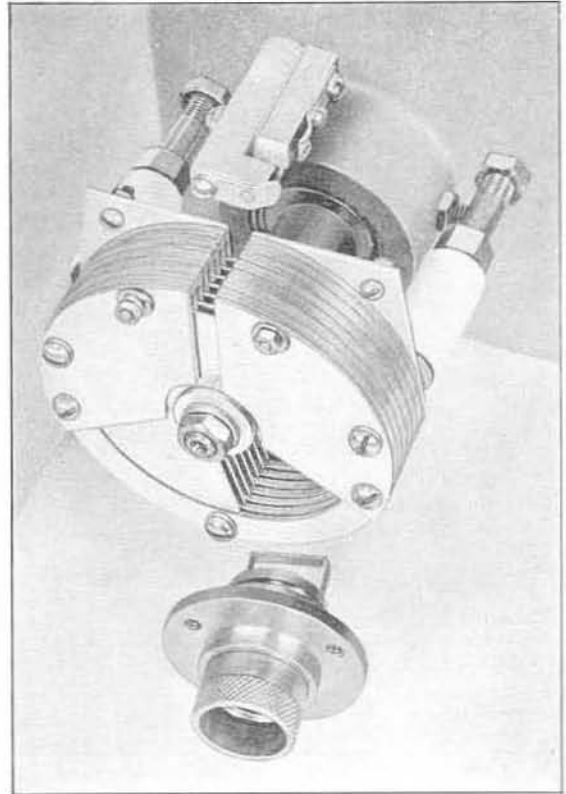

View of the tuned circuit of the TYPE 857-A Oscillator, showing also the output coupling loop and output jack in approximately their normal position.

| Type | Code Word | Price |
|-------|--------------------------------------|----------|
| 857-A | U-H-F Oscillator (with Power Supply) | OFTEN |
| | | \$285.00 |

PATENT NOTICE. See Note 10, page vi.

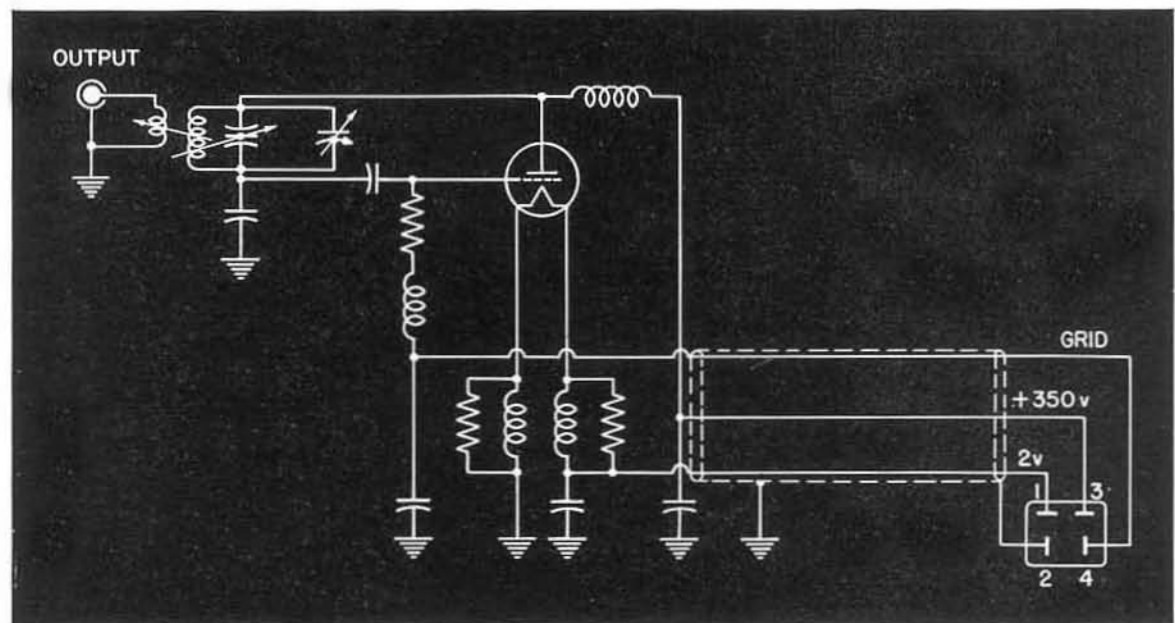



TYPE 869-A PULSE GENERATOR

USES: The pulse generator is intended for use in tests on circuits designed to pass short electrical pulses. It generates pulses of either positive or negative polarity, whose width can be set to any value between 0.3 and 70 microseconds and whose repetition rate can be controlled between 20 and 4000 cycles per second from an external a-c source. Complete shielding of the entire instrument makes it useful for pulsing standard-signal generators and similar apparatus, where extremely low voltage levels are encountered.

DESCRIPTION: The microsecond pulses are generated in an output amplifier stage by driving the control grid between the limits of plate-current cutoff and plate-current saturation. Either positive or negative output pulses are provided by switching the load resistance into the cathode or plate circuit. The amplitude of the pulse is continuously adjustable by means of a screen voltage control. A negative bias voltage applied to the grid of this tube maintains the tube in a cutoff condition between pulses. During the pulse period a high positive bias is applied to the grid.

The positive pulse, used to control the output amplifier, is derived from a circuit

employing two gas-triodes. The output amplifier grid is coupled to the center point of these series-connected gas-triodes which are, in turn, placed across a capacitor. A positive d-c potential is developed across the capacitor terminals by charging it from the power supply through a suitable series resistance.

When the first gas-triode becomes conducting, the positive capacitor voltage appears across both the output amplifier grid and the other gas-triode. Conduction in the second gas-triode removes the positive voltage from the amplifier grid. Simultaneously, the two gas-triodes now present a low-impedance path across the capacitor and discharge it. When the capacitor terminal voltage falls below a critical value, both gas-triodes deionize and resume their normal non-conducting state. The capacitor then recharges through the series resistor and the circuit is ready for a second pulse operation.

FEATURES: ▶ A continuous range of adjustment on pulse width is obtained by using variable circuit elements in the simple R-C circuit that controls the time delay between the conduction periods of the two gas-triodes.

▶ An output voltage is provided for controlling a high-speed sweep circuit.



- ▶ A limited phase adjustment is provided between the output and the internal synchronizing amplifier. This permits adjustment of the timing of the pulse with respect to the high-speed sweep circuit of an external oscilloscope.
- ▶ The timing of the pulse and the sweep

circuit can be maintained within a fraction of a microsecond, even at the lowest repetition rates, by means of the synchronizing circuit, which has a high degree of control. This condition is necessary if microsecond pulses are to be visible clearly on cathode-ray screens.

SPECIFICATIONS

Repetition Rate: 20 to 4000 cycles. Pulses longer than 10 microseconds are limited to a maximum frequency of 1000 cycles.

Input Voltage: Between 5 and 10 volts are required for normal control. For improved stability at the lowest frequencies, this may be increased to a maximum of 30 volts.

Input Voltage Waveform: This is not critical, and may vary from a sine wave to a triangular wave. Care must be taken, however, to keep this signal reasonably free from power supply hum voltage.

Synchronizing Output: A clipped sine wave of approximately -160 and +50 peak volts appears across the synchronizing output terminals. This may be used to control the high-speed sweep circuit of an oscillograph that has been provided with suitable triggering amplifiers.

Pulse Amplitude Control: A panel control permits the pulse amplitude to be adjusted from zero to maximum, with a negligible effect upon the pulse waveform.

Pulse Waveform: The pulse is essentially flat-topped, and has an effective rise time of 0.1 microsecond for pulse widths less than 10 microseconds. For longer pulses, the rise time is less than 10% of the pulse width.

Output Selector: A panel switch permits any one of four impedances to be inserted in the output amplifier, and also provides either positive or negative pulses.

Pulse Widths: The output pulse is continuously adjustable over three ranges. These are 0.3-3.0, 3-10, and 10-70 microseconds, respectively. The calibration of these con-

trols is approximately correct over the entire frequency range.

Output Amplitude: See table below.

Phasing Controls: Panel controls are provided to permit adjustable phasing of the output pulse over a limited range, with respect to the voltage obtained at the synchronizing output terminals.

Power Supply: 115 (or 230) volts, 50-60 cycles. A variation of ±10% in the supply voltage will cause a minor variation in the output pulse amplitude, and will generally tend to change the pulse width. For optimum performance, operation at the 115- or 230-volt value is recommended. Power input is 60 watts.

Accessories Required: To drive the generator an a-c source is needed. The General Radio TYPE 913-C Beat-Frequency Oscillator is recommended.

Accessories Supplied: A seven-foot line connector cord and one TYPE 774-R2 Patch Cord are supplied.

Tubes Supplied with Instrument:

| | |
|--------------|--------------|
| 2-6H6 | 2-884 |
| 1-6AC7 | 1-6SC7 |
| 1-6X5 | 1-6ZY5-G |
| 1-0D3 /VR150 | 1-0C3 /VR105 |
| 1-6SN7-GT | 1-6L6 |

Mounting: Metal cabinet.

Dimensions: (Length) 19 x (height) 9¾ x (depth) 12¼ inches, over-all.

Net Weight: 29 pounds.

PEAK OUTPUT VOLTS — OPEN CIRCUIT

| Pulse Polarity Output Setting | Positive | | | | Negative | | | | Operating Frequency* |
|-------------------------------|----------|--------|-------|-------|----------|-------|--------|-------|----------------------|
| | 20 KΩ | 1000 Ω | 500 Ω | 100 Ω | 100 Ω | 500 Ω | 1000 Ω | 20 KΩ | |
| Range A | 90 | 80 | 70 | 20 | 18 | 80 | 150 | 300 | 500 ~ |
| Range B | 100 | 90 | 80 | 20 | 18 | 90 | 170 | 300 | 500 ~ |
| Range C | 100 | 80 | 80 | 20 | 18 | 90 | 180 | 300 | 500 ~ |

*For other operating frequencies, the voltages will be within approximately 20% of the values given above. In general, the open circuit output voltage will tend to decrease as the pulse width and operating frequency increase.

| Type | Code Word | Price |
|-------------------------------|-----------|----------|
| 869-A Pulse Generator | OLIVE | \$330.00 |

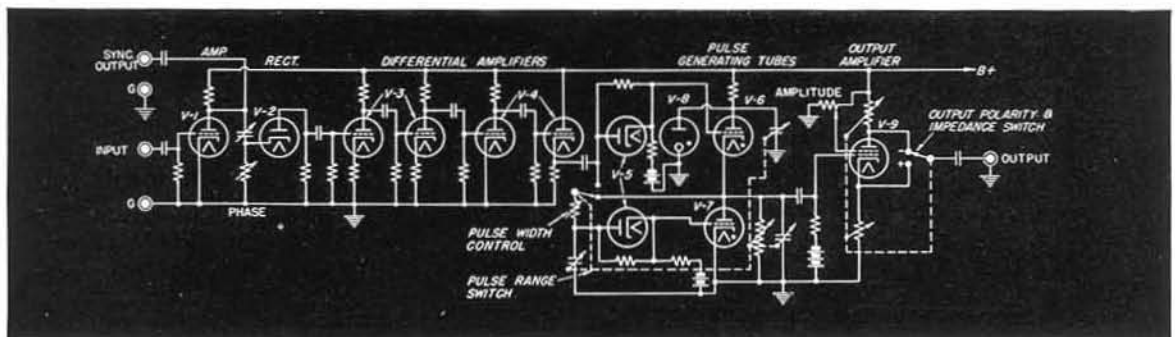

TYPE 723 VACUUM-TUBE FORK

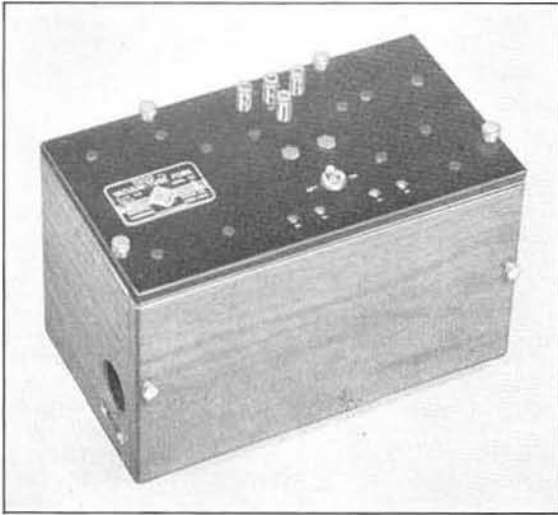

USES: The Type 723 Vacuum-Tube Fork is a compact, stable, fixed-frequency oscillator. It is particularly useful as a modulating source for standard-signal generators and beacon transmitters, as a power source for impedance bridges and for transmission measurements on lines and cables, and as a test-tone generator for communication sys-

tems. Its waveform is sufficiently pure to permit its use as a test-signal source for many types of distortion measurements. It is an excellent source of timing pulses for oscillograms. The 440-cycle model is a source pitched at International "A."

DESCRIPTION: This instrument is an electro-mechanical oscillator whose frequency is determined by a vacuum-tube driven tuning fork. The driving and pickup coils are so arranged as to load the tines of the fork equally and to affect only slightly its free vibration.

Space is provided in the cabinet for mounting batteries or an a-c power-supply unit. (See price list on next page.)

FEATURES: ▶ Excellent accuracy and stability of frequency are the outstanding features of this oscillator.

▶ Low harmonic content is obtained by the use of a filter, and an output transformer is used to provide three output impedances.

▶ A-c operation and constant output make this fork especially valuable where long periods of operation are necessary.

SPECIFICATIONS

Frequencies: Three frequencies are available, 400, 440, and 1000 cycles.

Frequency Stability: The temperature coefficient of frequency is approximately -0.008% per degree Fahrenheit. The frequency is entirely independent of load impedance. When the a-c power supply is used an initial downward drift of frequency occurs as the temperature of the fork is affected by heat generated in the power-supply unit. The total frequency drift is of the order of 0.15% to 0.2% . Most of this drift, however, occurs in the first 30 minutes of operation.

The voltage coefficient of frequency is negligible over the normal range of battery or a-c supply voltages.

Accuracy: The stabilized frequency is adjusted to within $\pm 0.05\%$ of its specified value, at a room ambient of 77° Fahrenheit.

Output: The output to a matched load is approximately 50 milliwatts.

Internal Output Impedance: Output impedances of 50, 500, and 5000 ohms are provided.

Waveform and Hum Level: The total harmonic content is less than 0.5% . The hum is negligible.

Terminals: Binding posts for the output circuit are mounted on the panel. Battery terminals are brought out to sunken screw heads on the panel to permit measurement of the battery voltages.

Power Supply: The instrument is available for either battery operation or for operation from 105- to 125-volt 40- to 60-cycle line. For battery operation one Burgess 4FH ($1\frac{1}{2}$ -volt) and two Burgess Z30NX (45-volt) are required. The batteries and a-c power supply are interchangeable. The power supply, Type 723-P1, is available separately. (See price list.) The ON-OFF switch is arranged to control the a-c line or the battery current.

Vacuum Tubes:

For battery supply: 1—1A5-GT/G

For a-c supply: 1—1A5-GT/G

1—0C3/VR105

The necessary tubes are supplied.

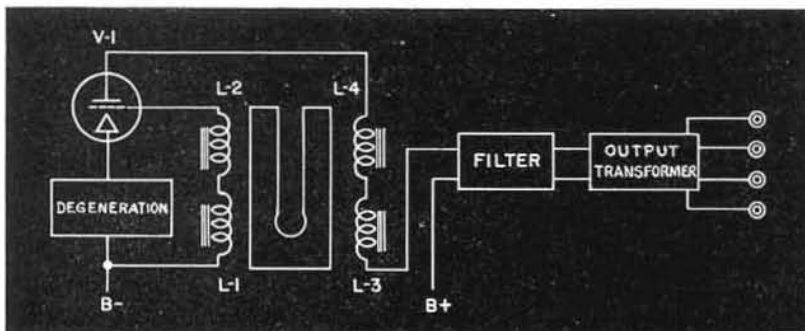

Schematic wiring diagram of Type 723 Vacuum-Tube Fork.



Accessories Supplied: A seven-foot line connector cord is supplied with the a-c operated model.

Dimensions: (Length) $10\frac{3}{8}$ x (width) $6\frac{1}{4}$ x (height) $7\frac{3}{4}$ inches, over-all.

Mounting: The oscillator assembly is mounted on a phenolic panel and is enclosed in a walnut cabinet.

Net Weight: $11\frac{1}{4}$ pounds, including batteries; $9\frac{1}{4}$ pounds, with a-c supply; a-c power supply alone, $1\frac{1}{4}$ pounds.

| Type | Frequency | Power Supply* | Code Word | Price |
|--------|--|--------------------------------------|------------|----------|
| 723-A | 1000 cycles | Batteries | SNAKE | \$115.00 |
| 723-C | 1000 cycles | 105 to 125 volts, 40 to 60 cycles | SOLID | 140.00 |
| 723-E | 440 cycles | Batteries | SOBER | 125.00 |
| 723-F | 440 cycles | 105 to 125 volts, 40 to 60 cycles | STUDY | 150.00 |
| 723-B | 400 cycles | Batteries | STORY | 115.00 |
| 723-D | 400 cycles | 105 to 125 volts, 40 to 60 cycles | SULKY | 140.00 |
| 723-P1 | A-C Operated Power Supply Only . . . | | SNAKEYPACK | 40.00 |
| 723-P2 | Set of Replacement Batteries | | SNAKEYBATT | 5.39 |

*Included in price.

TYPE 813-A AUDIO OSCILLATOR

USES: The TYPE 813-A Audio Oscillator is intended for the same general applications as the TYPE 723 Vacuum-Tube Fork, but where the requirements of waveform, stability, and output are not so severe.

DESCRIPTION: This instrument is a battery-operated electro-mechanical oscillator in which the frequency is determined by a tuning fork. Two microphone buttons, one for the driving circuit and one for the output circuit, are mounted at the side of the fork in such a manner as to load the tines equally and to affect only slightly the free vibration of the fork.

The fork itself is mounted rigidly at the heel beneath a metal base panel, which carries the driving electromagnet. This base panel is suspended from the phenolic panel with four resilient mountings.

A filter and output transformer are placed inside the cabinet underneath the fork. A battery compartment is also provided although external batteries may be used, if desired.

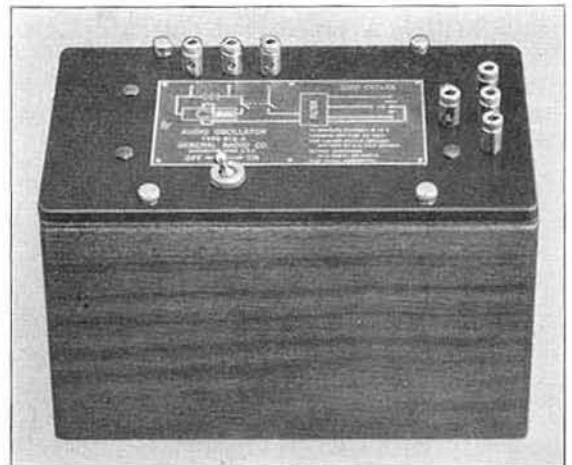

FEATURES: Good waveform and frequency stability are among the features of this convenient tuning-fork oscillator. The mechanical construction is rugged and the fork is protected from dirt and external injury.

Schematic wiring diagram of TYPE 813-A Audio Oscillator

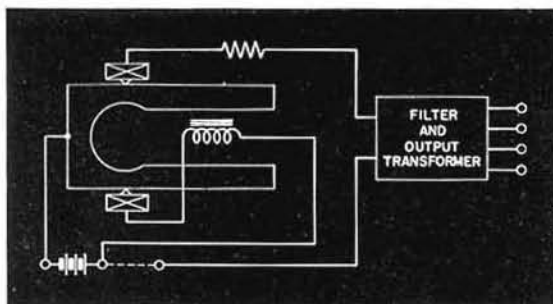

SPECIFICATIONS

Frequency: 1000 cycles.

Frequency Stability: The temperature coefficient of frequency is -0.008% per degree Fahrenheit. The voltage coefficient is less than 0.01% per volt. The frequency is entirely independent of load impedance.

Accuracy: The frequency is adjusted within 0.5% of its specified value. The actual frequency is measured, at a stated temperature between 70 and 80 degrees Fahrenheit, and recorded on the base of the cabinet to an accuracy of 0.1% .

Output: The output to a matched load impedance is 20 to 30 milliwatts with 6-volt drive and 10 to 15 milliwatts

OSCILLATORS

with $4\frac{1}{2}$ -volt drive. When the oscillator is operated continuously for several hours, the output may drop below these values.

Internal Output Impedance: Output impedances of 50, 500, and 5000 ohms are provided.

Waveform: The total harmonic content is approximately 0.75% with $4\frac{1}{2}$ -volt drive and approximately 1% with 6-volt drive.

Power Supply: For intermittent operation with a moderate power output, an internal $4\frac{1}{2}$ -volt battery can be

used. For greater output or continuous operation, an external battery of $4\frac{1}{2}$ to 6 volts should be used. Batteries are not supplied.

Terminals: Binding posts for external batteries, if used, and for the output circuit are provided on the panel.

Mounting: The fork is suspended from a metal plate on a phenolic panel and is enclosed in a walnut cabinet.

Dimensions: (Length) 9 x (width) 5 x (height) 6 inches, over-all.

Net Weight: $8\frac{1}{2}$ pounds.

| Type | Frequency | Code Word | Price |
|-------|-------------|-----------|---------|
| 813-A | 1000 cycles | ANGEL | \$70.00 |

TYPE 572-B MICROPHONE HUMMER

USES: The hummer is intended for use as a low-power a-c source for bridge and other measurements where extreme purity of waveform and frequency stability are not essential. This type of oscillator is used in the TYPE 650-A Impedance Bridge as the 1000-cycle internal generator.

DESCRIPTION: A tuned reed determines the frequency of this electro-mechanical oscillator. A microphone button is mounted near the reed to pick up energy for continuing the oscillations.

FEATURES: The TYPE 572-B Microphone Hummer is extremely compact, convenient, simple to use, and inexpensive.

SPECIFICATIONS

Frequency: 1000 cycles $\pm 10\%$.

Output Power: Approximately 15 milliwatts with $4\frac{1}{2}$ -volt drive.

Internal Output Impedance: Two impedances are available, 10 or 300 ohms.

Waveform: In this type of oscillator, distortion varies considerably with mechanical adjustment, driving volt-

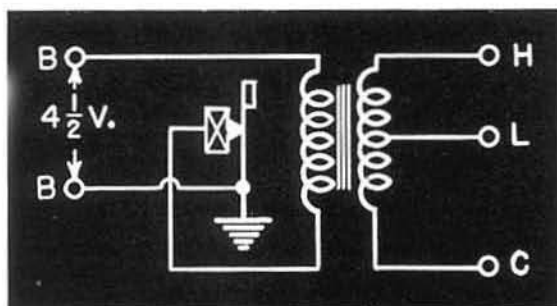
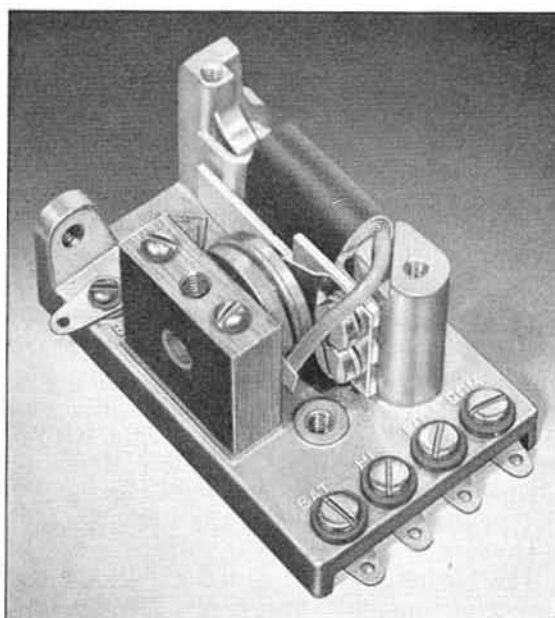

age, and other operating parameters. Consequently, no definite specifications can be given.

Power Supply: The hummer is designed to operate from a $4\frac{1}{2}$ -volt battery. A 6-volt drive can be used if more power is desired.

Terminals: Soldering lugs are provided.

Mounting: A cast-aluminum mounting base is used. (See photograph.)

Dimensions: (Length) $3\frac{1}{4}$ x (width) $2\frac{1}{8}$ x (height) 1 $\frac{1}{8}$ inches, over-all.

Net Weight: 9 ounces.

| Type | Code Word | Price |
|---------------------------------|-----------|---------|
| 572-B Microphone Hummer | APHIS | \$12.50 |

LOW-FREQUENCY TUNING-FORK OSCILLATORS

suitable for use as frequency standards are described on pages 191 to 193.

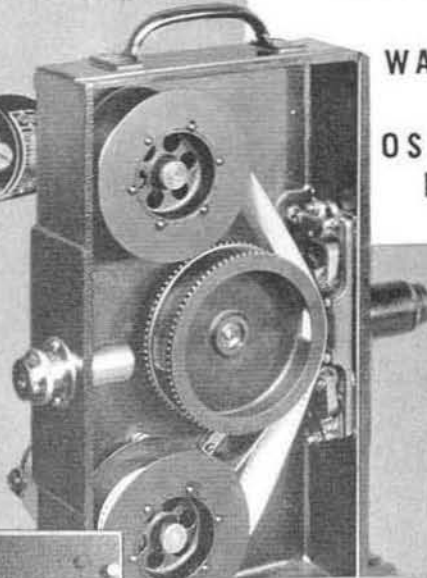
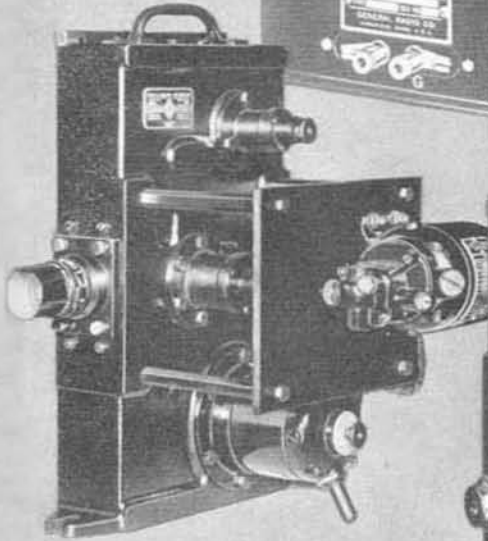

WAVEFORM

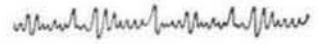

WAVE ANALYZER
•
MODULATION METER
•
DISTORTION METER
•
WAVE FILTERS
•
OSCILLOGRAPH
RECORDER

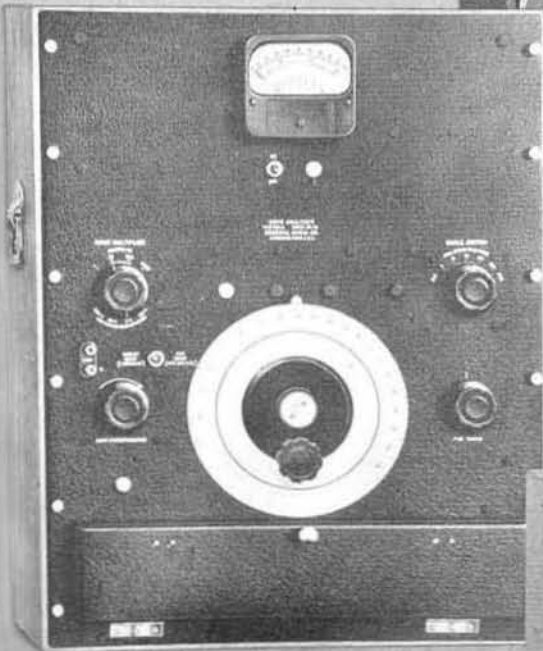

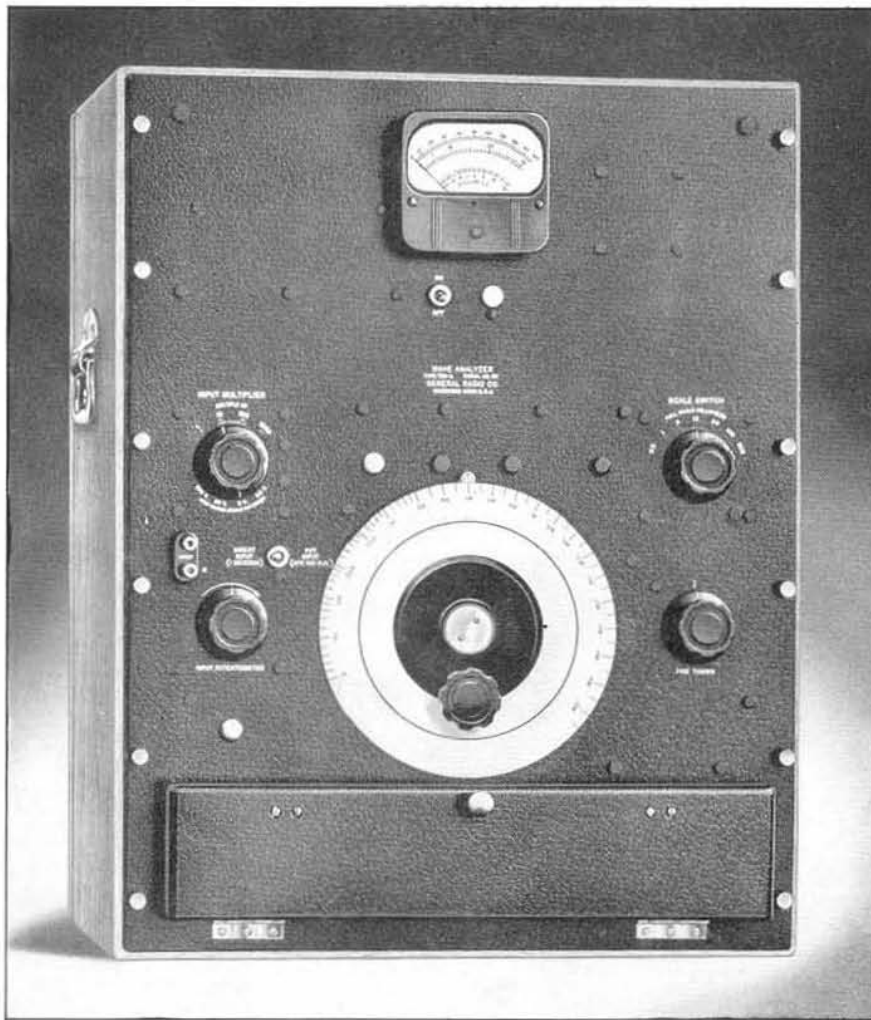

TYPE
736-A
WAVE
ANALYZER

USES: The wave analyzer is used to measure the amplitude and frequency of the components of a complex electrical waveform. These include not only the components of harmonic distortion, but also those of intermodulation distortion, noise, and hum.

Specific uses of the TYPE 736-A Wave Analyzer include the measurement of distortion components in audio-frequency equipment, broadcast receivers and transmitters, telephone systems, public address equipment, oscillators, amplifiers, and vacuum-tube circuits in general; harmonic studies on electric power systems and electrical machinery; hum measurement in a-c operated communication equipment; noise analysis; and induction studies on telephone lines. As a sharply tuned voltmeter, it is invaluable in the measurement of the transmission characteristics of electric wave filters.

DESCRIPTION: The TYPE 736-A Wave Analyzer is a heterodyne type of vacuum-tube voltmeter. The intermediate-frequency ampli-

fier includes a highly selective filter using three quartz crystals. The use of a heterodyne method makes it possible to vary the response frequency while using a fixed-frequency filter.

The output of the local oscillator and the whole of the complex waveform to be examined are fed to a balanced modulator where their combination produces both the sum and difference frequencies, or side bands, in the output. The original of the complex waveform is not passed by the modulator intermediate-frequency output transformer, and the local oscillator carrier frequency is suppressed in the output because of the two-tube balanced modulator employed.

The 50-kilocycle component of the upper side band, proportional to the voltage of that frequency present in the original wave to which the main dial is set, is selected and amplified by the intermediate stages. The adjustable gain control of the amplifier makes it possible to measure a wide range of voltages.



FEATURES: ▶ A "flat top" characteristic as shown by the curve at the right is obtained by using the three-crystal filter. This feature makes tuning easier and increases the stability of the tuning adjustment.

▶ A very wide range of input voltages — 1,000,000 to 1, full scale — can be accommodated directly.

▶ Self-contained calibrating systems make it possible to standardize the voltage and frequency calibrations easily at any time.

▶ The input impedance is constant at 1 megohm, but a built-in 100,000-ohm potentiometer is provided as an alternate input system where absolute voltage levels need not be determined.

▶ External magnetic fields cause no trouble because the balanced modulator is fed by a phase inverter tube, rather than by a transformer.

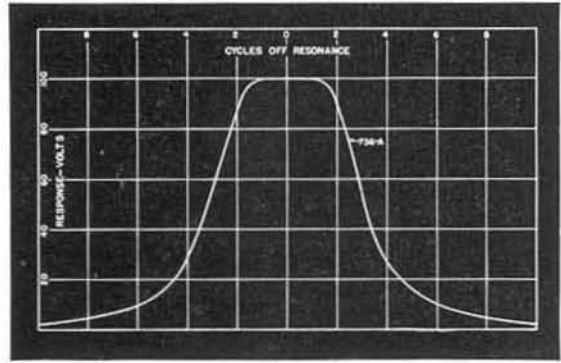

Transmission characteristic of the crystal filter in the TYPE 736-A Wave Analyzer.

▶ Humidity effects are minimized by hermetically sealing all critical parts including the crystals.

SPECIFICATIONS

Frequency Range: 20 to 16,000 cycles.

Selectivity: Approximately 4 cycles "flat top" band width. The response is down 15 db at 5 cycles, 30 db at 10 cycles, 60 db at 30 cycles from the peak. The selectivity is constant over the frequency range.

Voltage Range: 300 microvolts to 300 volts full scale. The lowest division on the meter corresponds to 10 μ v. The over-all range is divided into four major ranges; 300 μ v to 300 mv, 3 mv to 3 v, 30 mv to 30 v, 0.3 v to 300 v. Each of these ranges is divided into seven scale ranges; for example, the 0.3 v to 300 v range has the following full-scale ranges: 0.3 v, 1 v, 3 v, 10 v, 30 v, 100 v, 300 v. A direct-reading decibel scale is also provided.

Voltage Accuracy: Within $\pm 5\%$ on all ranges. Spurious voltages from higher order modulation products introduced by the detector are suppressed by at least 70 db. Hum is suppressed by at least 75 db.

Input Impedance: One megohm when used for direct voltage measurements. When used with the input potentiometer it is approximately 100,000 ohms.

Accuracy of Frequency Calibration: $\pm (2\% + 1 \text{ cycle})$.

Vacuum Tubes Required:

- 3—6C6
- 2—6K6-GT/G
- 3—6J7
- 1—6B8
- 1—6C5
- 1—6X5-GT/G
- 1—6F5-GT/G
- 3—TYPE 2LAG-949 neon lamps

These are supplied with the instrument.

Power Supply: A-C line, 105 to 125 volts, 40 to 60 cycles. A change in the power transformer connection permits the use of 210 to 250 volts, 40 to 60 cycles. A voltage-stabilizing circuit is included. Power input is about 65 watts.

Accessories Supplied: Spare neon lamp, one TYPE 274-NE Shielded Connector, and a line connector cord.

Mounting: Shielded oak cabinet.

Dimensions: (Width) $19 \frac{1}{2}$ x (height) $25 \frac{1}{8}$ x (depth) $10 \frac{3}{8}$ inches, over-all.

Net Weight: $86 \frac{1}{4}$ pounds.

| Type | Code Word | Price |
|---------------------|-----------|----------|
| 736-A Wave Analyzer | ASKEW | \$920.00 |

PATENT NOTICE. See Notes 19, 27, page vi.

The TYPE 760-A Sound Analyzer and the TYPE 762-B Vibration Analyzer, analyzers having a constant percentage band width, and designed primarily for sound and vibration analyses, are described on pages 13 and 17.

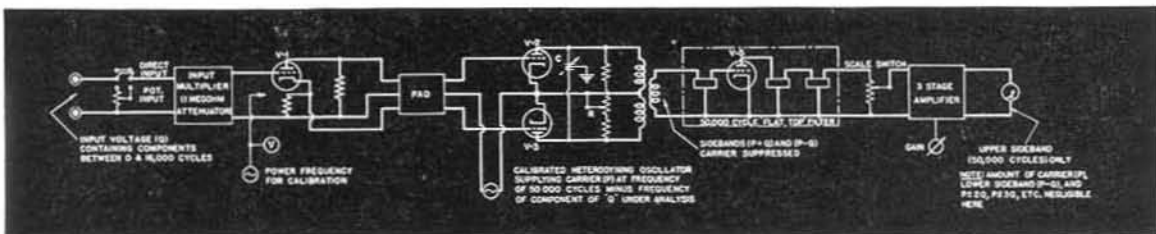

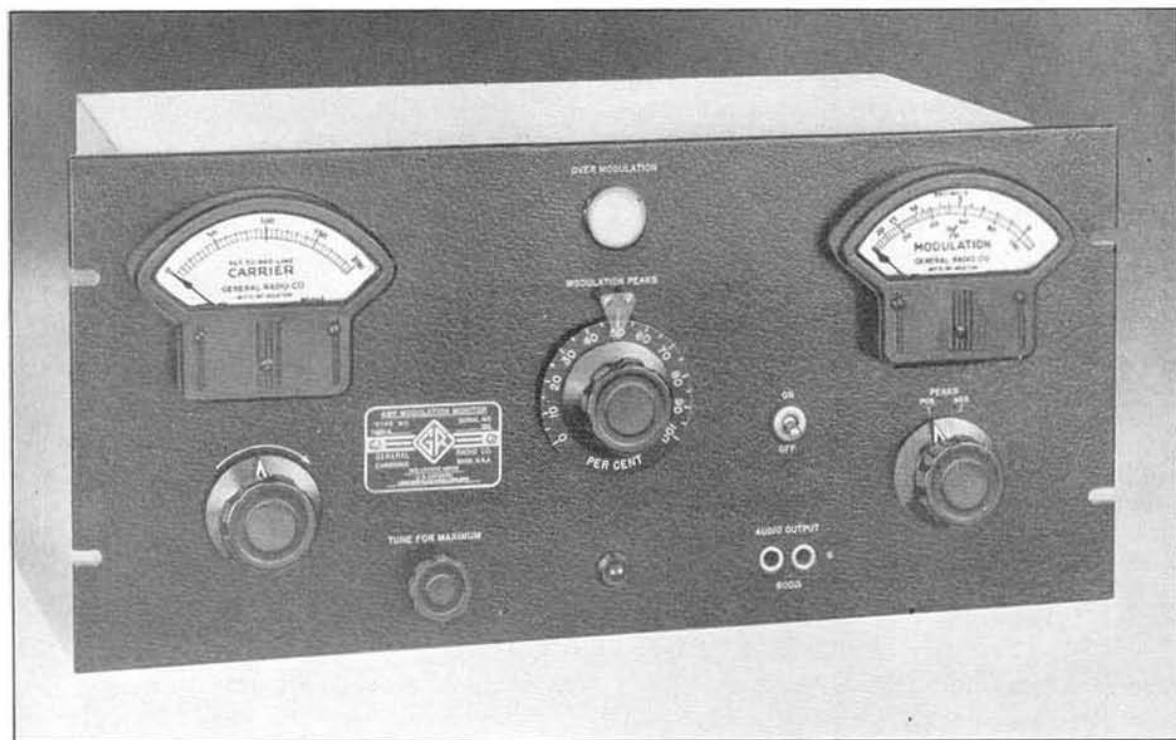

TYPE 1931-A AMPLITUDE-MODULATION MONITOR

USES: The modulation monitor is used to measure and to indicate continuously the percentage modulation of broadcast and other radio-telephone transmitters. The TYPE 1931-A Modulation Monitor performs the following specific functions:

1. Measurement of percentage of modulation on either positive or negative peaks.
2. Overmodulation indication.
3. Program level monitoring.
4. Measurement of carrier shift when modulation is applied.
5. Measurement of transmitter audio-frequency response.

DESCRIPTION: TYPE 1931-A Modulation Monitor consists of three essential elements: (1) a linear diode rectifier which gives an instantaneous output voltage proportional to the carrier envelope, (2) a semi-peak voltmeter which gives a continuous indication of the peak modulation, and (3) a trigger circuit which flashes a light whenever the negative modulation peaks momentarily exceed any previously set value.

The linear rectifier is designed for operation at a low power level, which greatly simplifies the coupling to the transmitter. In the output of the linear rectifier is a d-c meter, which indicates the carrier level at which the instrument is operating and also shows any carrier shift during modulation.

In addition, two auxiliary audio output circuits operating from a separate diode rectifier are provided. One of these, at 600 ohms, is intended for audible monitoring; the other, a high-impedance circuit, gives a faithful reproduction of the carrier envelope with less than 0.1% distortion and can be used for distortion and noise-level measurements.

FEATURES: ▶ Speed and simplicity of operation, essential for monitoring instruments, are available in this instrument. It operates over a wide carrier-frequency range, and a tuned input circuit is provided to facilitate coupling to the transmitter.

▶ The r-f power input is only a fraction of that required by older models.

▶ The flashing lamp is extremely useful as a monitoring device. It is set to flash with moderate frequency when the transmitter is operating normally. If the flashing rate changes markedly the operator is made aware that the average level of modulation has changed.

▶ The flashing circuits are so designed that the indication is unaffected by moderate changes in carrier amplitude.

▶ Terminals are provided so that remote percentage modulation indicators can be connected to the instrument externally.

▶ F. C. C. Approval No. 1555 has been issued for this monitor.

SPECIFICATIONS

Range: Modulation percentage, 0 to 110%, indicated by meter on positive peaks, 0 to 100% on negative peaks. The flashing lamp is adjustable to operate from 0 to 100% on negative peaks.

Carrier-Frequency Range: The monitor will operate at any carrier frequency from 0.5 to 60 megacycles. A single set of coils (either 0.5 to 8 megacycles or 3 to 60 megacycles) is supplied with each instrument, unless both sets are specifically ordered.

Carrier-Frequency Input Impedance: About 75 ohms in the broadcast band, increasing slightly at higher carrier frequencies and varying somewhat with input tuning.

Accuracy: The overall accuracy of measurement at 400 cycles is $\pm 2\%$ of full scale at 0% and 100%, and $\pm 4\%$ of full scale at any other modulation percentage.

Detector Linearity: The distortion in the diode detector is very low for frequencies up to 7500 cycles. Above this frequency, a small amount of negative peak clipping occurs, reaching 5% at the extreme high end of the audio range at 15,000 cycles and 100% modulation.

R-F Power: In the broadcast range the maximum r-f power requirement is about 0.5 watt.

Vacuum Tubes: The following tubes are used:

- 2-6SN7-GT 1-2050
- 2-6SJ7 2-0D3 /VR150
- 1-6AL5 1-6X5

Warning Lamp Circuit: The OVERMODULATION lamp will flash whenever the negative modulation peaks exceed the setting of the MODULATION PEAKS dial by approximately 2% modulation, for audio frequencies between 30 and 7500 cycles. For higher audio frequencies, the percentage overmodulation required to flash the lamp increases slightly.

The accuracy of the dial calibration is approximately $\pm 2\%$ of full scale.

Meter Circuit: The response of the PERCENTAGE MODULATION meter circuit is flat, within ± 0.25 db, between 50 and 15,000 cycles, and within ± 0.1 db between 100 and 10,000 cycles.

Either positive or negative modulation peaks may be read. Calibration in db below 100% modulation is provided.

The meter dynamic characteristic meets FCC specifications for modulation monitors.

Audio Monitoring Output: The audio output amplifier is flat, within ± 1.0 db, from 30 to 45,000 cycles. The internal impedance is 600 ohms. Distortion is less than 0.2%. Open-circuit output voltage is about 300 millivolts.

Fidelity-Measuring Output: Flat within ± 1.0 db between 30-15,000 cycles with TYPE 1932-A Distortion and Noise Meter connected.

Output level varies inversely with setting of MODULATION PEAKS dial, thus providing reasonably uniform input to distortion meter at all modulation levels. Average output level, approximately 1.5 volts.

Residual noise and hum level will not exceed -80 db.

Auxiliary Output: A multipoint connector at the rear of the instrument provides a means of connecting:

1. A remote Percentage Modulation Meter.
2. To a 600-ohm output for audio monitoring.
3. The TYPE 1932-A Distortion and Noise Meter.

Power Supply: 105 to 125 (or 210 to 250) volts, 50 to 60 cycles. Power input is approximately 50 watts.

Accessories Supplied: Multipoint connector, line connector cord, and one set of input tuning coils (specify frequency range desired).

Mounting: The instrument is relay-rack mounted. Walnut end frames are available for table mounting. (See price list below.)

Panel Finishes: Standard General Radio black crackle. Certain standard grays which can be processed in quantity can be supplied at a price increase of \$11.00.

Dimensions: Panel (length) 19 x (height) 8 $\frac{3}{4}$ inches. Depth behind panel, 10 inches.

Net Weight: 32 $\frac{3}{4}$ pounds.

| Type | | Code Word | Price |
|-------------|---|------------|------------|
| 1931-A | Modulation Monitor, 0.5 to 8 Mc | TARRY | \$395.00 |
| 1931-A | Modulation Monitor, 3 to 60 Mc | TOPIC | 395.00 |
| 1931-P5 | Extra Tuning Coils, 0.5 to 8 Mc | TABBY | 16.50 |
| 1931-P6 | Extra Tuning Coils, 3 to 60 Mc | TOTEM | 16.50 |
| ZFRI-510-P1 | End Frames | ENDFRAMEAT | 16.50 Pair |

PATENT NOTICE. See Notes 1, 13, 21, 22, 25, page vi.

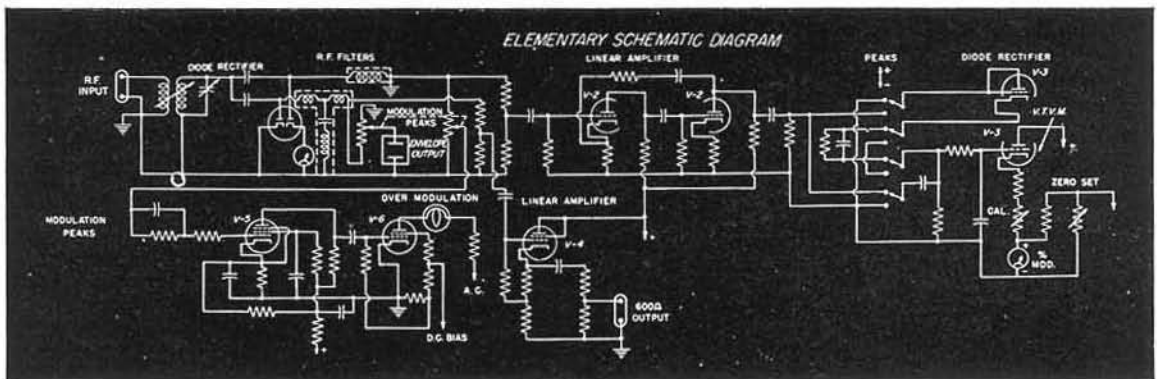

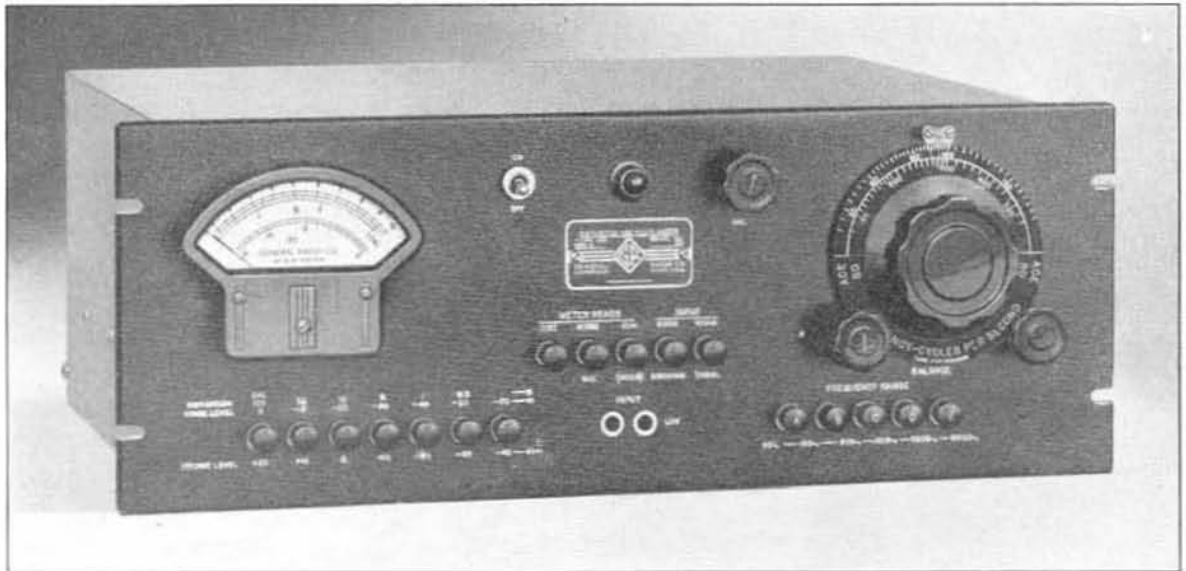

TYPE 1932-A DISTORTION AND NOISE METER

USES: The TYPE 1932-A Distortion and Noise Meter measures distortion, noise, and hum level in audio-frequency circuits. In conjunction with the TYPE 1931-A Modulation Monitor, it can be used to measure these quantities directly in the output of radio broadcasting transmitters. It finds many uses in the communications laboratory and in the production testing of radio receivers as a wide-range, highly sensitive voltmeter for such measurements as signal-to-noise ratio, AVC characteristics and hum level.

DESCRIPTION: The principal elements of the distortion and noise meter are a high-gain amplifier with an R-C interstage coupling unit that balances to a sharp null, a calibrated attenuator for adjusting the sensitivity, and a vacuum-tube voltmeter. Degeneration maintains a high degree of stability in amplifier gain and also a flat transmission characteristic except within an octave of the null frequency. The null frequency is continuously variable and is controlled by a dial on the panel. The function of the null network is to eliminate the fundamental of the audio-frequency signal, leaving only the distortion products, which are indicated directly on the panel meter.

The null network is switched out of the circuit for noise and hum measurements, and the instrument then operates as a highly sensitive voltmeter. Two input circuits are provided: (1) a transformer for bridging a 600-ohm line; and (2) a direct connection to the 100,000-ohm gain control. The latter is used when measurements are made on the modulated output of a radio transmitter in conjunction with the TYPE 1931-A Modulation Monitor.

FEATURES: ▶ Continuous adjustment of frequency over the entire audio range is provided in this instrument.

- ▶ Any frequency can be selected quickly since there is only one main tuning control, with an auxiliary trimmer.
- ▶ Frequencies up to 45,000 cycles are passed by the amplifier circuits so that distortion measurements can be made on fundamental frequencies up to 15,000 cycles.
- ▶ Distortion values as low as 0.1% can be measured, since the lowest range is 0.3% full scale.
- ▶ The auxiliary dbm calibration on the range switch adds considerably to the usefulness of the instrument.

SPECIFICATIONS

Distortion Range: Distortion is read directly from a large meter. A multiplier allows full-scale deflections for 0.3%, 1%, 3%, 10% or 30% distortion.

Noise Measurement Range: The range for carrier

noise measurements extends to 80 db below 100% modulation, when the distortion meter is operated from the TYPE 1931-A Modulation Monitor, or 80 db below an audio-frequency signal of zero dbm level.



Audio-Frequency Range: 50 to 15,000 cycles (fundamental), for distortion measurements; 30 to 45,000 cycles for noise and hum measurements.

Dbm Range: The power-level range is from +20 to -60 dbm. Full scale values of +20, +10, 0, -10, -20, -30, and -40 dbm are provided. The scale is calibrated in terms of a reference level of one milliwatt in 600 ohms.

Input Voltage Range: The input signal level should be between 1.2 and 30 volts for the 100-kilohm input, and between 0.8 and 30 volts for the 600-ohm bridging input.

Accuracy: For distortion measurements, $\pm 5\%$ of full scale for each range \pm residual distortion as noted below; for noise and d.f.m. measurements, $\pm 5\%$ of full scale.

Residual Distortion Level:

- 100-Kilohm Input: 0.05%, maximum, below 7,500 cycles
- 0.10%, maximum, above 7,500 cycles
- Bridging Input: 0.10%, maximum, between 50 and 70 cycles
- 0.05%, maximum, between 70 and 7,500 cycles
- 0.10%, maximum, above 7,500 cycles

Residual Noise Level: Less than -80 db.

Input Impedance: Two input impedances are provided, 100,000 ohms unbalanced, and 600-ohm bridging input (10,000 ohms), balanced or unbalanced.

Meter: A large meter with an easily read, illuminated scale is provided. Percentage and decibel calibrations are included.

Vacuum Tubes:

- 4—6J5
- 1—6SN7-GT
- 1—6K6-GT/G
- 1—6H6
- 1—6X5
- 2—0D3 /VR150

Accessories Supplied: Line connector cord and cable for connecting to the TYPE 1931-A Modulation Monitor.

Other Accessories Required: For measuring the distortion in oscillators and other audio-frequency sources, no additional equipment is required. For measurements on amplifiers, lines, and other communication networks, a low-distortion oscillator is required to furnish the test tone. TYPE 1301-A Low-Distortion Oscillator (see page 118) is recommended. When the modulated output of a radio transmitter is to be measured, a linear rectifier to produce the audio envelope is necessary. The TYPE 1931-A Modulation Monitor is recommended for this purpose. (See page 132.) However, any detector system having minimum undistorted output of 1.5 volts rms can be used.

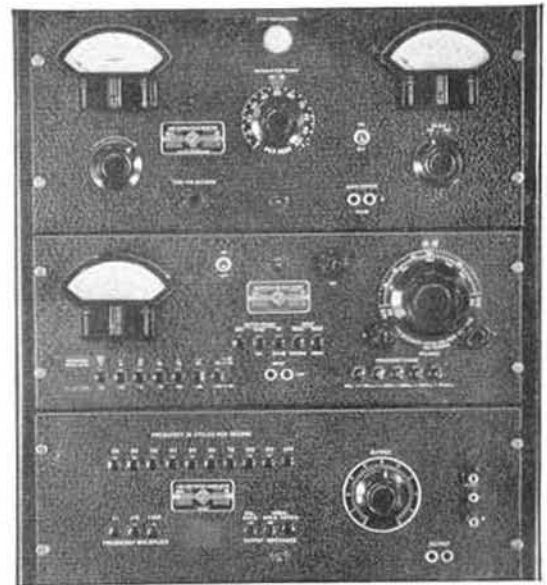

A relay-rack assembly of broadcasting test equipment showing, from top to bottom, TYPE 1931-A Amplitude-Modulation Monitor, TYPE 1932-A Distortion and Noise Meter, and TYPE 1301-A Low-Distortion Oscillator.

Terminals: Input terminals are provided at the rear of the instrument for direct connection to the modulation monitor. A Western Electric jack is provided at the panel also, as an auxiliary input circuit. Plugging into this jack automatically disconnects the rear connectors.

Power Supply: 105 to 125 (or 210 to 250), volts, 50 to 60 cycles. The line input power is 65 watts. The power supply is voltage regulated. Line surges have no appreciable effect.

Mounting: The instrument is relay rack mounted. Walnut end frames are available to adapt the instrument for table mounting. (See price list below.)

Panel Finishes: Standard General Radio black crackle. Certain standard grays which can be processed in quantity can be supplied at a price increase of \$11.00.

Dimensions: Panel (length) 19 x (height) 7 inches; depth behind panel, 12 inches.

Net Weight: 37 $\frac{3}{4}$ pounds.

| Type | Code Word | Price |
|-----------------------------------|------------|------------|
| 1932-A | TABOO | \$575.00 |
| ZFRI-412-P1 | ENDFRAMDIG | 16.50 Pair |
| Distortion and Noise Meter | | |
| End Frames | | |

PATENT NOTICE. See Note 25, page vi.

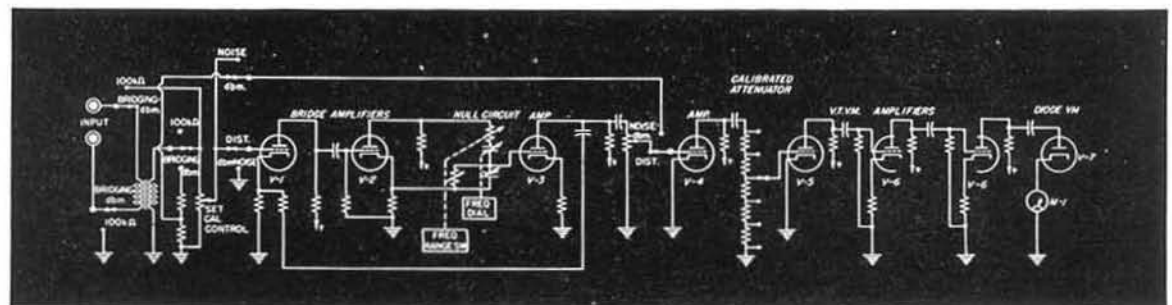

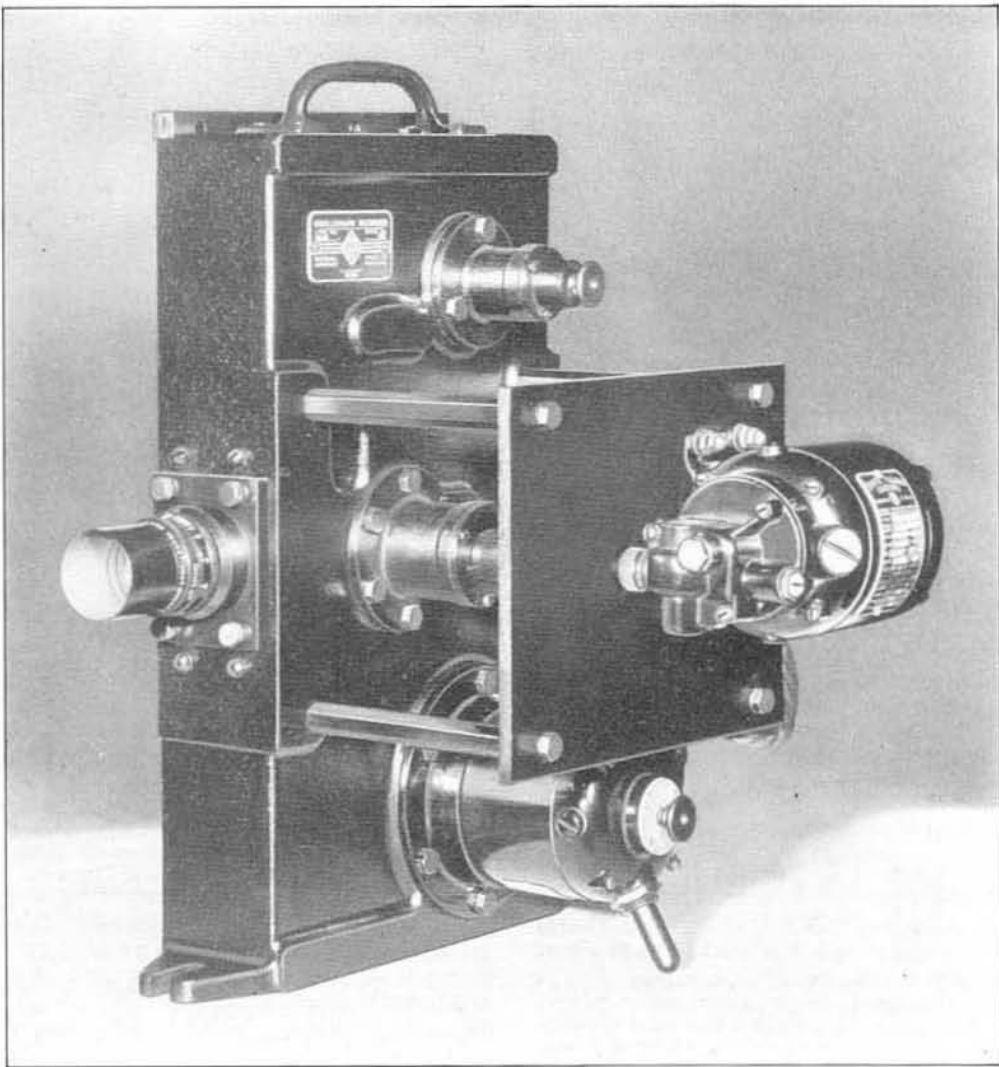

TYPE 651-AE OSCILLOGRAPH RECORDER

USES: This device is suitable for recording the trace of a cathode-ray oscillograph to obtain an accurate record of transient phenomena. Typical applications are the study of the response of electrical networks to suddenly applied voltages, the recording of switching transients, and the study of the instantaneous variations of voltages and currents in electrical machinery under arbitrary load variations.

DESCRIPTION: In the TYPE 651-AE Oscillograph Recorder the film is driven continuously past the aperture, so that the trace of the cathode-ray spot is recorded as a continuous line.

The accompanying photograph shows the internal construction of the recorder. The large central driving sprocket and the bottom take-up reel are driven by separate motors.

The torque characteristics of the motors are such that the proper film tension is maintained as the film passes from the loading reel to the take-up reel. Focusing is accomplished by viewing the image through the focusing eyepiece when the two apertures in the driving sprocket are aligned as shown. The image forms on a small piece of translucent film which can be located on the sprocket.

FEATURES: ▶ A wide range of film speeds, extending up to 35 feet per second, can be obtained by varying the voltage applied to the driving and take-up motors. With special motors very slow speeds can also be obtained.
 ▶ The lens mounting is arranged to permit focusing over a wide range of distances. A simple and direct focusing means is provided.
 ▶ Reels will hold a full 100 feet of film and are interchangeable.

SPECIFICATIONS

Film: Any 35-mm film or paper with standard perforations can be run. Daylight loading and unloading with negligible waste.

Film-Speed Range: When the motors are operated at the voltages mentioned below, film speeds between 5 and 35 feet per second are obtainable. At the highest recommended operating voltage, higher speeds will sometimes be obtained.

Motors geared for lower speed ranges can be supplied on special order.

Lens System: Lens must be purchased separately. A lens of aperture $f/1.5$ and 2-inch focal length is available in an adjustable mounting that permits focusing for distances between 8 and 100 inches. (See price list.) The image for focusing is observed directly on the equivalent of a ground glass in the plane of the film. The lens is equipped with an iris diaphragm.

This lens is sufficiently "fast" to permit the recording of traces from a cathode-ray oscillograph on supersensitive panchromatic film at a speed of 35 feet per second, when the ratio of total length along the trace to length of film is less than 5 to 1.

Oscillograph Screen: A low-persistence actinic blue screen, such as one with a P5 or P11 phosphor, should be used for best results.

Reels: Specially made reels for loading and take-up are supplied. Capacity of reels, 100 feet.

Drive System: Both the film-drive sprocket and the take-up reel are driven by universal (a-c or d-c) motors. The film speed is varied by applying voltages between 50 and 230 volts to these motors.

Speed Control: When 115-volt or 230-volt, 50- to 60-cycle service is available, a TYPE V-5HMT or TYPE V-5H Variac may be used to vary the voltage applied to the motors. For d-c service, resistance methods of voltage control must be used.

Starting Characteristics: Full operating speed is reached in approximately 10 feet of film travel, at

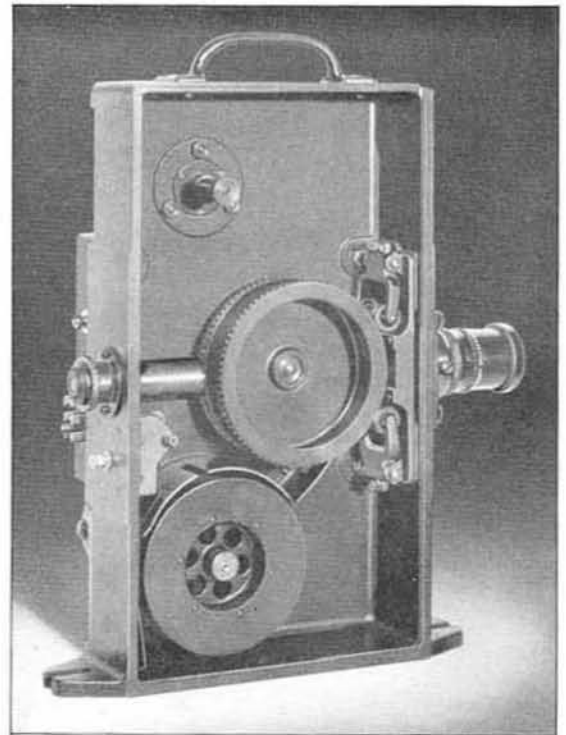

Interior view of recorder showing film sprocket, take-up reel, and focusing eyepiece.

maximum speed. At lower speeds less film is consumed in reaching operating speeds.

Dimensions: (Length) $11\frac{3}{8}$ x (width) $6\frac{1}{2}$ x (height) $16\frac{1}{2}$ inches, over-all.

Net Weight: 32 pounds.

| Class | Description | Code Word | Price |
|---------|----------------------------------|-----------|----------|
| *651-AE | Oscillograph Recorder | DINER | \$550.00 |
| 651-P5 | Lens, $f/1.5 \times 2.0''$ | DIARY | 165.00 |

*Without lens.
PATENT NOTICE. See Note 15, page vi.

STROBOSCOPIC RECORDERS

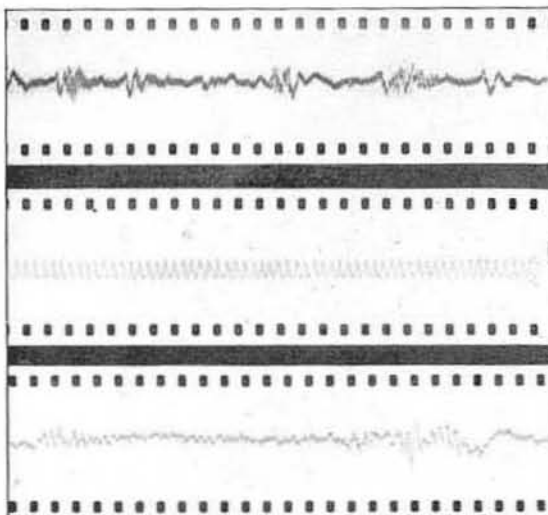

For recording high-speed phenomena by means of stroboscopic light, the TYPE 651-AG Camera is available. This differs from the conventional motion-picture camera in that no shutter is employed. A commutator is provided on the sprocket to trip a stroboscope at single-frame intervals, so that the photographic record is properly framed for projection. Although the film is continuously in motion, the stroboscopic flash is so short in duration that no blur of the image is noticeable. Speeds up to 1500 frames per second can be obtained. A complete description of the TYPE 651-AG Camera and the TYPE 1533A High-Speed Motion-Picture Assembly is given on pages 6 and 7.

Oscillograms taken with the TYPE 651-AE Oscillograph Recorder.

TYPE 830 WAVE FILTERS



USES: Electric wave filters are widely used for the elimination of harmonics from distorted waveforms, for the isolation of specific components of complex waveforms, and, in general, to remove voltages of undesired frequencies from measuring and communications circuits.

DESCRIPTION: Type 830 Wave Filters are compact, two-section filters having exceptionally good characteristics. They are available in low-pass, high-pass, and band-pass models. The sections co-operate to give both a sharp cut-off and high discrimination against frequencies outside the pass band.

The band-pass model, Type 830-R, is sharply tuned to pass 1000 cycles and discriminate against other frequencies, the design being such that a maximum of attenuation is provided for the second harmonic at 2000 cycles. The input and output coils of this unit are tapped so that the filter can be used with high or low terminating impedances, or to replace the combination of a filter and transformer to work between different impedances.

The attenuation characteristics are the same for either connection on the two-impedance side, but differ somewhat for different connections on the four-impedance side. From the plot at the right, it will be seen that greatest attenuation to harmonics is obtained on the 5000-ohm output tap. An attenuation

peak at the second harmonic occurs when the 500- and 5000-ohm taps on the four-impedance side are used. This peak is not present with the other two taps.

Since either side may be used as input or output, two different connections are possible when working between 500 and 5000 ohms. From the curves shown, it is evident that somewhat better characteristics will be obtained if the 500-ohm connection is made at the two-impedance side.

FEATURES: ▶ The attenuation at the cut-off frequency is less than 3 decibels for the high-pass and low-pass models, and for the band-pass model the attenuation at the desired frequency is only 5 or 6 decibels. (See accompanying curves.) The curves also show that a discrimination of at least 40 decibels is maintained for all frequencies greater than 1.5 times the cut-off frequency for the high-pass types.

▶ An excellent band-pass filter covering one octave may be obtained by using the 500-cycle high-pass and the 1000-cycle low-pass in tandem. The curve of attenuation vs. frequency for this combination is shown on the next page.

▶ The combinations of input and output impedances available with the Type 830-R are such that this filter may be worked from either a 500-ohm line or a vacuum tube (plate resistance approximately 5000 ohms) into a circuit of almost any impedance with satisfactory results.

Attenuation characteristics of Type 830-R Band-Pass Filter for the various terminating impedances.

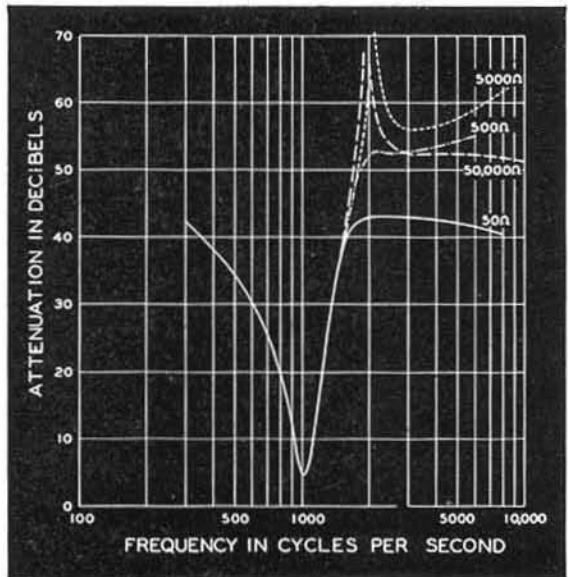

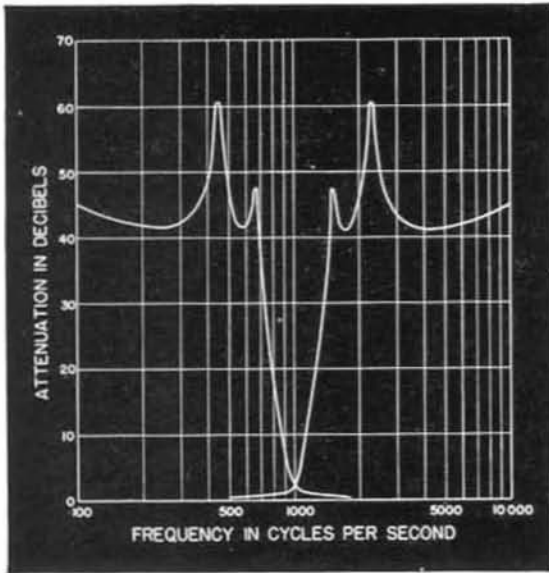

Characteristics of 1000-cycle low-pass and 1000-cycle high-pass filters.

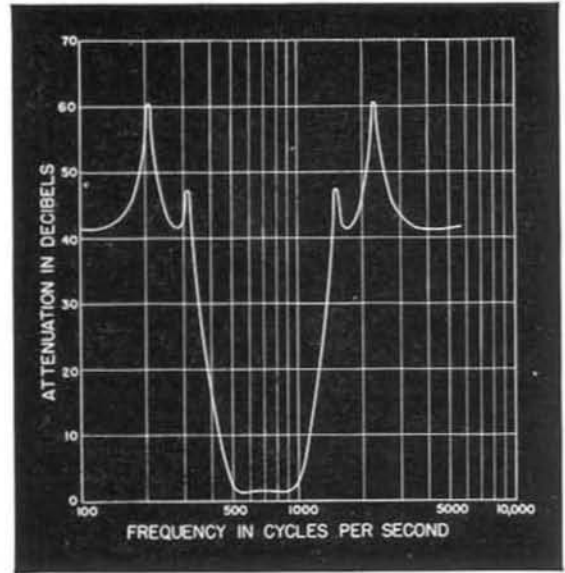

The 500-cycle high-pass and 1000-cycle low-pass models can be used in tandem to give a one-octave band-pass characteristic.

SPECIFICATIONS

Attenuation Characteristic: See accompanying curves.
Voltage Limit: Voltages up to approximately 3 volts at any frequency may be applied to the 500-ohm filter (10 volts for 5000-ohm filter) input terminals without significantly altering the response curves. At higher voltage levels, slight shift in the location of the attenuation peaks may be expected.
Terminals: Types S30-A to S30-H inclusive are provided with both soldering lugs and jack-top binding posts. Type S30-R has soldering lugs only.

Mounting: All models except Type S30-B are mounted in Model C cases. Type S30-B is mounted in a Model D case.
Dimensions: See dimensions for Model C and Model D cases on next page. An extra 1/4 inch must be allowed in the depth for the projection of the terminals on all models except Type S30-R.
Net Weight: Type S30-B, 7 1/2 pounds; all others, 3 1/2 pounds.

| Type | Cut-Off Frequency | Impedance | | Code Word | Price |
|-------|-------------------|--|-----------|------------|---------|
| 830-A | 500 cycles | 500 Ω | Low-Pass | FILTERGOAT | \$30.00 |
| 830-B | 500 cycles | 500 Ω | High-Pass | FILTERGIRL | 30.00 |
| 830-C | 500 cycles | 5000 Ω | Low-Pass | FILTERSHOE | 30.00 |
| 830-D | 500 cycles | 5000 Ω | High-Pass | FILTERSEAT | 30.00 |
| 830-E | 1000 cycles | 500 Ω | Low-Pass | FILTERTOAD | 30.00 |
| 830-F | 1000 cycles | 500 Ω | High-Pass | FILTERMUSH | 30.00 |
| 830-G | 1000 cycles | 5000 Ω | Low-Pass | FILTERSIGN | 35.00 |
| 830-H | 1000 cycles | 5000 Ω | High-Pass | FILTERPIPE | 35.00 |
| 830-R | 1000 cycles | { 5000, 500 Ω 50,000, 5000, 500, 50 Ω } | Band-Pass | FILTERROTE | 35.00 |

OTHER FILTERS

A 400-cycle band-pass filter, TYPE 530, for use in distortion measurements, is described on the next page.



TYPE 530-A BAND-PASS FILTER

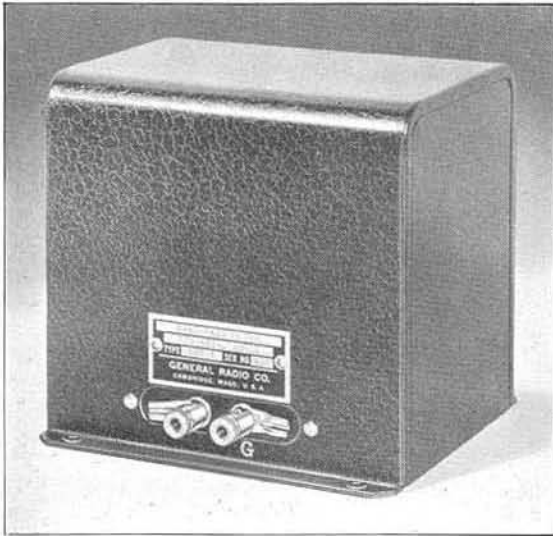

View of TYPE 530-A Filter.

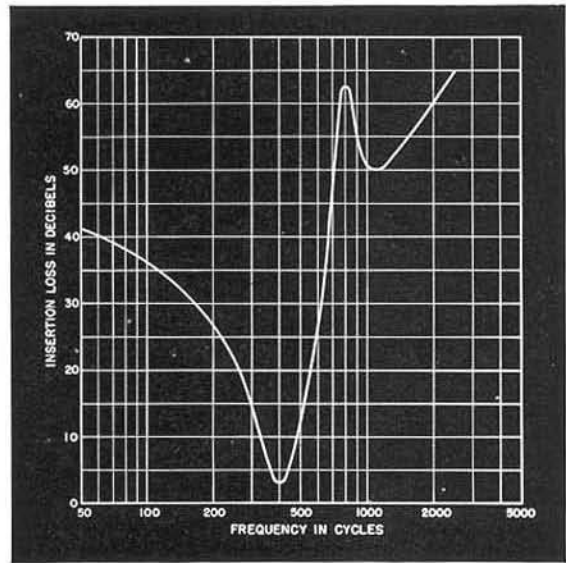

Transmission characteristics of TYPE 530-A Band-Pass Filter.

This filter is designed for use with a 400-cycle oscillator to provide a very pure signal for distortion measurements, and for other applications where only an extremely small harmonic content can be tolerated. It may

be used with fundamental frequencies from 375 to 425 cycles, providing an attenuation of at least 50 decibels to all harmonics. In addition considerable attenuation to power-line frequencies is provided.

SPECIFICATIONS

Attenuation Characteristic: (See accompanying curve.) A peak of maximum attenuation is set for rejection of the 800-cycle second harmonic.

Voltage Limit: Voltages up to approximately 3 volts at any frequency may be applied to the filter input terminals without significantly altering the response curve. At higher voltage levels slight shift in the location of the attenuation peak may be expected.

Mounting: Filters are mounted in standard drawn steel, wax-filled Model D cases.

Dimensions: Case, (width) $5\frac{3}{4}$ x (height) $5\frac{1}{4}$ x (depth) $5\frac{1}{2}$ inches, over-all. (See also dimensioned drawing below.)

Net Weight: 8 pounds.

| Type | Impedance | Pass Band | Code Word | Price |
|-------|-----------|-------------------|-----------|---------|
| 530-A | 600 ohms | 375 to 425 cycles | FOCAL | \$35.00 |

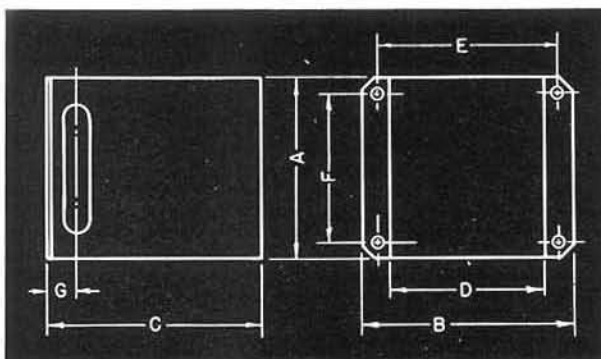

DIMENSIONS OF FILTER CASES

| | MODEL B | MODEL C | MODEL D |
|---|-------------------------|------------------------|------------------------|
| A | $2\frac{13}{16}$ inches | $3\frac{3}{16}$ inches | $5\frac{3}{4}$ inches |
| B | $3\frac{1}{8}$ inches | 4 inches | $5\frac{1}{4}$ inches |
| C | $4\frac{1}{8}$ inches | $4\frac{1}{8}$ inches | $5\frac{5}{16}$ inches |
| D | $2\frac{5}{16}$ inches | $3\frac{1}{16}$ inches | $4\frac{1}{4}$ inches |
| E | $2\frac{3}{4}$ inches | $3\frac{1}{2}$ inches | $4\frac{3}{4}$ inches |
| F | $1\frac{7}{8}$ inches | $2\frac{7}{8}$ inches | $4\frac{1}{2}$ inches |
| G | $\frac{5}{8}$ inch | $\frac{5}{8}$ inch | $\frac{5}{8}$ inch |





METERS

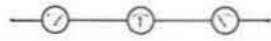

VACUUM-TUBE
AND
RECTIFIER-TYPE
VOLTMETERS

•
MICROVOLTER

•
MEGOHMMETERS

•
OUTPUT-POWER METERS

•
COUNTING RATE METER



METERS

Direct-reading instruments for the measurement of voltage, current, power, resistance, and other quantities are indispensable items in the electronics laboratory. The General Radio Company has always pioneered in the development and manufacture of specialized types for radio and electronic measurements. Its earliest products in this field were hot-wire ammeters and high-sensitivity galvanometers.

When suitable vacuum tubes became commercially available, the first General Radio vacuum-tube voltmeter, the TYPE 426, was designed. In 1937, the first commercial peak-indicating type was announced, a development stemming from similar circuits used earlier in modulation meters. For radio-frequency voltage measurement, development has been pointed toward higher and higher frequencies, as new and better vacuum tubes became available. The new TYPE 1800-A which represents the best performance available from present-day commercial tubes, operates at frequencies up to 500 megacycles. It also measures d-c voltages, and, with capacitance shunts, can be used for r-f current measurement. Its accuracy specification of $\pm 2\%$ is considerably better than has hitherto been achieved in vacuum-tube voltmeters.

Beyond this frequency, similar circuits using a crystal diode instead of a vacuum tube have made possible the TYPE 1802-A Crystal Galvanometer, which operates up to 1000 Mc. A pioneer instrument, this voltmeter is not as accurate as the vacuum-tube types used at lower frequencies, but fills a definite need in the radio laboratory for a voltage measuring device up to 1000 megacycles.

Combining the vacuum-tube voltmeter with the simple ohmmeter circuit has made possible the direct-reading megohmmeter, a convenient aid for rapid testing of high-valued resistors, insulation and capacitors. The TYPE 1861-A Megohmmeter can also be used as a high-resistance d-c voltmeter, a feature which adds considerably to its utility.

Early recognizing the utility and simplicity of oxide-rectifier-type instruments for audio-frequency work, General Radio engineers developed assemblies using resistive networks as constant impedance multipliers, such as the TYPE 483-F Output Meter.

Another adaptation of the rectifier type indicator is the direct-reading output-power meter with adjustable impedance input, represented in the current General Radio line by the TYPE 583-A and TYPE 783-A Output-Power Meters. With these meters, the power available from an audio-frequency source as a function of impedance can be quickly measured. When the meter impedance is adjusted for maximum power, the source impedance can be determined.

For portable use, the 727, 728, 729 series is available for measuring a-c volts, d-c volts and megohms. These are all battery-operated instruments, ideal for field use, but capable of laboratory accuracy. The TYPE 728-A Vacuum-Tube Voltmeter is an unusually versatile instrument, measuring d-c voltages from 0.05 to 3000 volts, and having an input resistance between 1000 and 5000 megohms for all scales.

For low-level voltage standardization, the audio-frequency microvoltmeter can be used. This instrument consists of a voltmeter for standardizing the input at a level of a few volts, followed by a calibrated attenuator to produce output voltages down to 0.1 microvolt. It is particularly useful in sensitivity and gain measurements on audio-frequency equipment.

For use in the rapidly developing radio-activity field, the new TYPE 1500-A Counting Rate Meter with its associated Geiger-Mueller counters is listed, the first of a new line of GR instruments for nuclear measurements.

Meters for measuring other quantities are listed in other sections of this catalog. The INDUSTRIAL section includes the TYPE 759-B Sound-Level Meter, for industrial noise measurements, and the TYPE 761-A Vibration Meter, for the measurement of acceleration, velocity and displacement in mechanical systems. In the WAVEFORM section will be found the TYPE 1931-A Modulation Monitor for measuring percentage modulation in radio transmitters; the TYPE 1932-A Distortion and Noise Meter, for over-all distortion and noise level measurements in transmitters and audio equipment; and the TYPE 736-A Wave Analyzer, a sharply tuned voltmeter operating over the range of 20 cycles to 16 kilocycles.



METERS

| Type No. | Name | Quantity Measured | Range | Nominal Frequency Range | Nominal Accuracy | Input Impedance | Power Supply | See Page Number |
|----------|-----------------------|-------------------|--|----------------------------|-----------------------|--------------------------|-----------------------------------|-----------------|
| 1800-A | Vacuum-Tube Voltmeter | Voltage | 0.1 to 150 volts, 1500 volts with multiplier | 20 cycles to 500 Mc | ±2% | 25 megohms, 3.1 μ af | 115 or 230 volts, 50 to 60 cycles | 146 |
| | | Voltage | 0.1 to 150 volts | dc | ±2% | 10 megohms or open grid | | |
| 1802-A | Crystal Galvanometer | Voltage | 0.1 to 100 volts | 30 Mc to 1000 Mc | ±5% | 5 μ af, 10,000 ohms | Batteries | 144 |
| 727-A | Vacuum-Tube Voltmeter | Voltage | 0.05 to 300 volts | 20 cycles to 50 Mc | ±3% | 5 megohms, 15 μ af | Batteries | 148 |
| 728-A | Vacuum-Tube Voltmeter | Voltage | 0.05 to 3000 volts | dc | ±3% | 1000 megohms or greater | Batteries | 150 |
| 483-F | Output Meter | Voltage | 0.05 to 200 volts | 20 cycles to 5000 cycles | ±5% | 20,000 ohms | None | 153 |
| 729-A | Megohmmeter | Resistance | 2000 ohms to 50,000 megohms | dc | ±5% | | Batteries | 151 |
| 1801-A | Megohmmeter | Resistance | 2000 ohms to 50,000 megohms | dc | ±5% | | 115 or 230 volts, 40 to 60 cycles | 152 |
| | | Voltage | 0 to 100 volts | dc | ±2% | 0.1 megohm to open grid | | |
| 583-A | Output-Power Meter | Power | 0.1 milliwatt to 5 watts | 20 cycles to 10,000 cycles | ±0.6 db | 2.5 to 20,000 ohms | None | 154 |
| | | Impedance | 2.5 to 20,000 ohms | | ±20% | | | |
| 783-A | Output-Power Meter | Power | 0.2 milliwatt to 100 watts | 20 cycles to 15,000 cycles | ±0.25 db | 2.5 to 20,000 ohms | None | 155 |
| | | Impedance | 2.5 to 20,000 ohms | | ±2% | | | |
| 546-C | Microvolter | Voltage | 0.1 microvolt to 1 volt | 20 cycles to 20,000 cycles | ±(3% + 0.5 microvolt) | 600 ohms (output) | Audio Oscillator | 158 |
| 1500-A | Counting-Rate Meter | Radio Activity | 5 to 20,000 counts per minute | | ±3% | | 115 or 230 volts, 50 to 60 cycles | 156 |



TYPE 1802-A CRYSTAL GALVANOMETER



USES: The crystal galvanometer is a direct-reading voltmeter for use at frequencies between 30 and 1000 megacycles. It can also be used as an indicator of voltage at frequencies up to 4000 megacycles. Although it reads directly in voltage, its absolute accuracy is not as good as that of General Radio vacuum-tube voltmeters, and for this reason it is cata-

loged as a galvanometer rather than as a voltmeter. Laboratories engaged in ultra-high-frequency measurements will find this instrument invaluable, since it extends by about three to one the upper frequency at which rapid, direct-reading voltage measurements can be made.

DESCRIPTION: Functionally, this instrument consists of a crystal rectifier and a d-c vacuum-tube amplifier. The crystal rectifier is built into a small shielded probe, and a cable carries the rectified voltage to the d-c amplifier and indicating meter in the cabinet. The probe is provided with a number of removable fittings, including 10:1 and 100:1 multipliers, a coaxial adapter, and a 50-ohm terminating resistor. The d-c amplifier uses a triode in a degenerative cathode-follower circuit.

Cathode and plate power is obtained from self-contained batteries. The cabinet has a storage compartment at the top for housing the probe and accessories.

- FEATURES:**
- ▶ The voltmeter scale is approximately linear.
 - ▶ Voltages up to 100 volts can be measured by using the convenient multipliers that are provided.
 - ▶ The normal variations in tube characteristics and battery voltages do not appreciably affect the meter indication.
 - ▶ The variety of probe terminations make the voltmeter adaptable to many types of measurement.
 - ▶ Batteries have an operating life of approximately 200 hours.
 - ▶ The calibration can be checked and adjusted in terms of a voltage obtained from a 40- to 60-cycle a-c power line.

Schematic diagram of
TYPE 1802-A Crystal
Galvanometer.

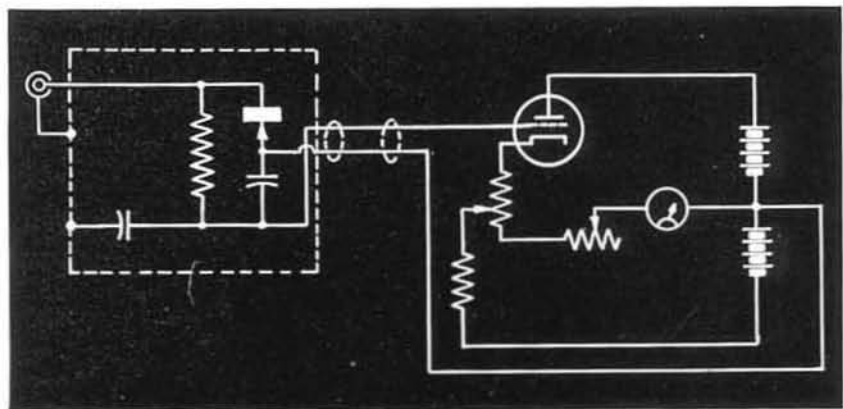

SPECIFICATIONS

Voltage Range: 0.1 to 1 volt, direct reading; 1 to 10 volts and 10 to 100 volts direct reading with multipliers supplied.

Accuracy: $\pm 5\%$ of full scale on sinusoidal voltages, subject to frequency correction.

Multiplier Accuracy: All multipliers are adjusted to have a multiplying factor within $\pm 5\%$ of the nominal value.

Waveform Error: The meter response approaches that of a peak voltmeter, but the scale is calibrated in r-m-s values for a sine-wave input. On distorted waveforms the percentage deviation of the reading from the r-m-s value may be as large as the percentage of harmonics present.

Frequency Error: The upper limit of usefulness is determined by the frequency of series resonance in the crystal probe, which varies among different crystals by some 10 or 15%. With a 1N21B crystal in the probe, the resonant frequency is between 1650 and 2000 Mc; with the 10:1 multiplier attached, between 1700 and 2200 Mc; and with the 100:1 multiplier attached, between 1350 and 1650 Mc.

The effect of resonance on the meter indication becomes appreciable at about 200 megacycles and causes the meter indication to be high. Correction can be made for this error by multiplying the meter indication by $\cos(\pi f/2f_0)$, where f is the operating frequency and f_0 is the resonant frequency. (The factor $1 - (f/f_0)^2$ is useful as an approximate correction when the frequency is much below resonance.) The correction as a function of frequency for the average of a number of crystals is given in the accompanying plot. The dotted lines represent the maximum deviations to be expected in individual crystals and may amount to $\pm 20\%$ of the indicated voltage at 1000 Mc. These corrections are for the voltage at the face of the probe with no probe terminals.

Correction curve for the TYPE 1802-A Crystal Galvanometer as a function of frequency. Uncertainties indicated by the shaded area at low frequencies and dotted lines at high frequencies arise from differences among crystals.

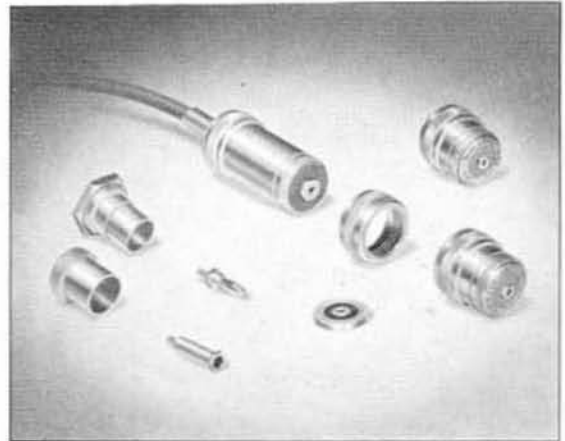
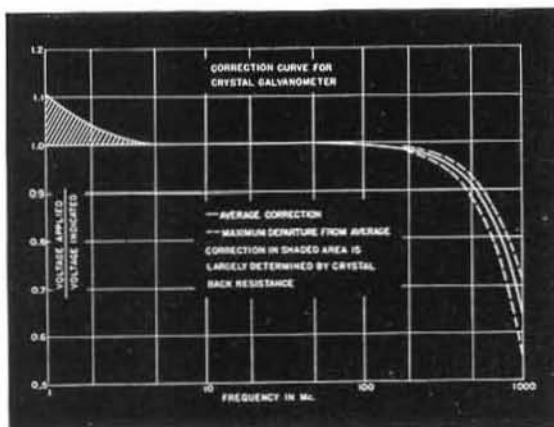

View of galvanometer probe including multipliers and termination accessories.

At frequencies below a nominal value between 10 and 30 Mc, the indication falls off as a result of the small series capacitance in the probe. The frequency at which this effect becomes noticeable depends upon the characteristics of the individual crystal, particularly the back resistance. Because the multipliers are capacitance voltage dividers, the limiting frequency is higher when they are used.

Input Impedance: The input capacitance is nearly independent of the standard crystal used, but the input conductance depends on the frequency, voltage level, and the crystal characteristics. For 1N21B crystals, at frequencies below 1000 Mc and voltage levels above a few tenths of a volt, representative values are:

| | |
|-------------------|---|
| Probe: | Capacitance — $5 \mu\text{mf}$ |
| | Conductance — $100 \mu\text{mhos}$ |
| 10:1 Multiplier: | Capacitance — $2.5 \mu\text{mf}$ |
| | Conductance — Less than $25 \mu\text{mhos}$ |
| 100:1 Multiplier: | Capacitance — $1.6 \mu\text{mf}$ |
| | Conductance — Less than $10 \mu\text{mhos}$ |

Power Supply: The necessary batteries, one Burgess Z30NX and one Burgess 2F, are supplied.

Vacuum Tube: One 1R5 vacuum tube is supplied.

Crystal: One 1N21B crystal is supplied.

Mounting: Black crackle aluminum panel mounted in a shielded walnut cabinet. The cable and probe are stored in the cabinet. The carrying handle can be set as a convenient support for the instrument when placed on a bench with the panel tilted back.

Accessories Supplied: One TYPE 1802-P1 10:1 Multiplier, one TYPE 1802-P2 100:1 Multiplier, one TYPE 1802-P3 Cable Termination, fittings for plugging into TYPE 774-G or 774-M coaxial connectors.

Dimensions: $7 \times 7 \times 10\frac{1}{2}$ inches, over-all.

Net Weight: $10\frac{1}{2}$ pounds.

| Type | Code Word | Price |
|----------------------|-----------|----------|
| 1802-A | CONIC | \$220.00 |
| Crystal Galvanometer | | |

TYPE 1800-A VACUUM-TUBE VOLTMETER (A-C OPERATED)

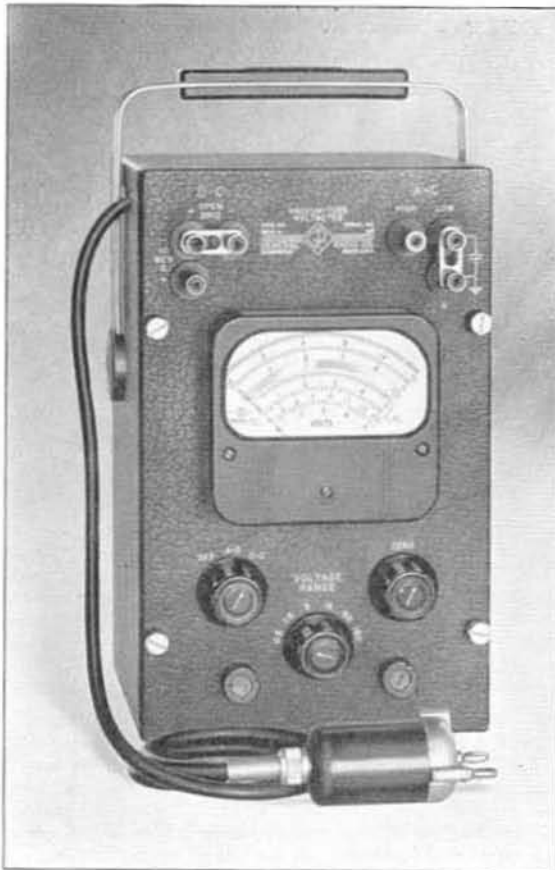

USES: The TYPE 1800-A Vacuum-Tube Voltmeter is a high-impedance wide-range voltmeter which can be used not only for measurements at audio and radio frequencies up to several hundred megacycles but also at dc.

In addition to its use as a voltmeter, the TYPE 1800-A can be used, with the special 50-ohm terminating resistor which is furnished, to measure current and power in the termination of lines or other locations.

Although calibrated to give the r-m-s values of approximately sinusoidal voltages, the voltmeter can be used, except on the lowest voltage ranges, to determine the peak value of a complex voltage wave.

DESCRIPTION: The high-frequency probe contains an acorn-type diode rectifier connected by very short leads to the input capacitor which is a small button-type unit mounted on a low-loss insulating disc. Except for the small area of this insulation at the front, the probe is completely shielded. A metal cap screws onto the end of the probe and is used to attach various fittings and terminations to the probe input. The cable, which also supplies heater power to the diode in the probe, carries the rectified voltage to a d-c amplifier and indicating meter in the cabinet of the instrument.

The d-c amplifier consists of a balanced twin triode operating in a highly degenerative circuit. The rectified alternating voltage is applied directly to the control grid of one triode, and a diode, that serves only to balance the effect of the initial-velocity current in the rectifying diode, is connected to the control grid of the second triode. Degeneration is obtained by connecting another twin triode in the cathode circuit of the amplifier. The indicating meter is connected in series with precision resistors between the cathodes of the amplifying twin triodes. The change from one voltage range to another is made by changing the value of this series resistance.

FEATURES: ▶ The input impedance is maintained at a high value over all the ranges of the voltmeter for both a-c and d-c measurements. Thus very little power is taken from the source being measured.

▶ Accurate measurements at frequencies up to several hundred megacycles can be made, because the small probe makes possible very short leads. The plug terminals on the probe can be removed to shorten the leads still further, or other fittings or terminations can be used instead.

▶ A permanent calibration substantially independent of tube characteristics is possible, because the degeneration in the d-c amplifier stabilizes the gain.

▶ The three highest a-c scales are practically linear, and there is sufficient overlapping of

Schematic circuit diagram of TYPE 1800-A Vacuum-Tube Voltmeter.

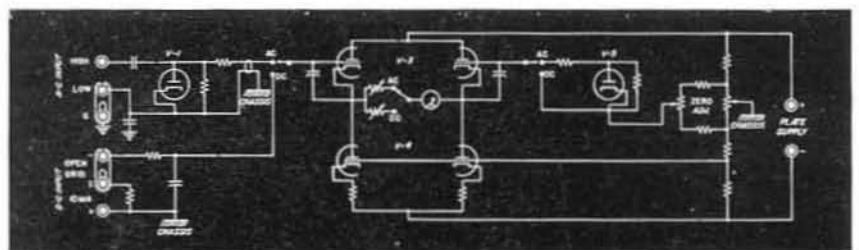

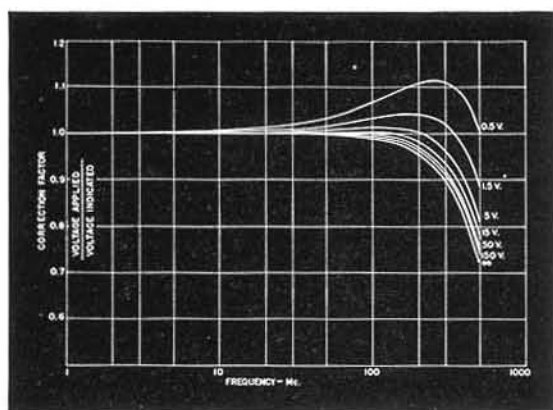
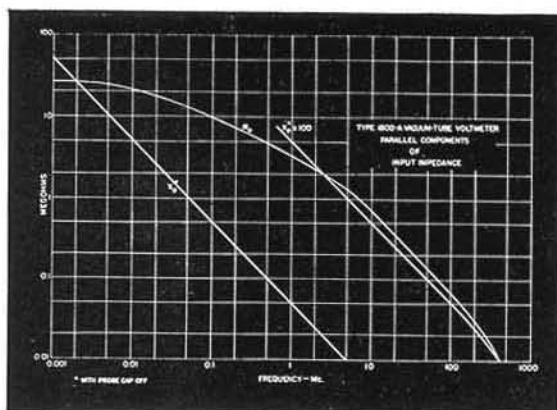

(Left) Plots of the resistance and reactive components of the input impedance of the TYPE 1800-A Vacuum-Tube Voltmeter. (Right) Plots showing ratio of applied voltage to indicated voltage as a function of frequency for various values of indicated voltage, taken with cap on but plug removed.

the various ranges so that all readings can be made well up on the scale.

► One zero adjustment control serves for all ranges, and resetting is not required from range to range. A regulated power supply

eliminates fluctuations in the zero setting or in the meter readings over a wide range of line-voltage variations.

► Overvoltages on any scale will not damage the instrument.

SPECIFICATIONS

Voltage Range: 0.1 to 150 volts, a-c, in six ranges (0.5, 1.5, 5, 15, 50, and 150 volts, full scale); 0.01 to 150 volts, d-c, in six ranges (0.5, 1.5, 5, 15, 50, and 150 volts, full scale).

Accuracy: DC, $\pm 2\%$ of full scale on all six ranges; AC, $\pm 2\%$ of full scale on all six ranges for sinusoidal voltages, subject to frequency correction (see below).

Waveform Error: On the a-c voltage ranges, the instrument operates as a peak voltmeter, calibrated to read r-m-s values of a sine wave, or 0.707 of the peak value of a complex wave. On distorted waveforms the percentage deviation of the reading from the r-m-s value may be as large as the percentage of harmonics present.

Frequency Error: At high frequencies, resonance in the input circuit and transit-time effects in the diode rectifier introduce errors in the meter reading. The resonance

effect causes the meter to read high and is independent of the applied voltage. The transit-time error is a function of the applied voltage and tends to cause the meter to read low. The accompanying curves give the frequency correction for several different voltage levels. It will be noted that at low voltages the transit-time and resonance effects tend to cancel, while at higher voltages the error is almost entirely due to resonance. The resonant frequency with cap on but plug removed is about 1050 Mc.

This voltmeter may be used at frequencies as low as 20 cycles with a frequency error of less than 2%.

Input Impedance: At low frequencies the equivalent parallel resistance of the a-c input circuit is 25 megohms. At higher frequencies this resistance is reduced by losses in the shunt capacitance. The equivalent parallel capacitance at radio frequencies is 3.1 μmf with the probe cap and plug removed. At audio frequencies this capacitance increases slightly. The probe cap and plug add approximately 1.2 μmf . The accompanying plot gives the variation of R_p and X_p with frequency.

On the d-c ranges two values of input resistance are provided, 10 megohms and open grid.

Power Supply: 105 to 125 volts (or 210 to 250) volts, a-c, 50 to 60 cycles. The instrument incorporates a voltage regulator to compensate for supply variations over this voltage range. The power input is less than 25 watts.

Tubes: Two 9005, two 6SL7-GT, one 6AT6, one 6C4, one 6X5-GT/G, one 3-4, and two 991 are used; all are supplied.

Accessories Supplied: A line connector cord, TYPE 274 and TYPE 774 terminations, and 50-ohm terminating resistor for probe.

Mounting: Black crackle finish aluminum panel mounted in a shielded walnut cabinet. The cable and probe are stored in the cabinet. The carrying handle can be set as a convenient support for the instrument when placed on a bench with the panel tilted back.

Dimensions: (Width) 7 $\frac{3}{8}$ x (depth) 7 $\frac{1}{2}$ x (height) 11 $\frac{1}{8}$ inches, over-all.

Net Weight: 13 $\frac{3}{4}$ pounds.

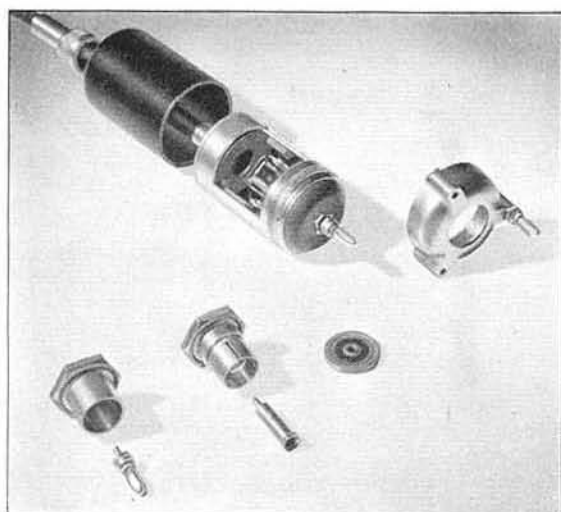

| Type | Code Word | Price |
|-----------------------------------|-----------|----------|
| 1800-A Vacuum-Tube Voltmeter..... | DUCAT | \$345.00 |

TYPE 1800-P2 MULTIPLIER

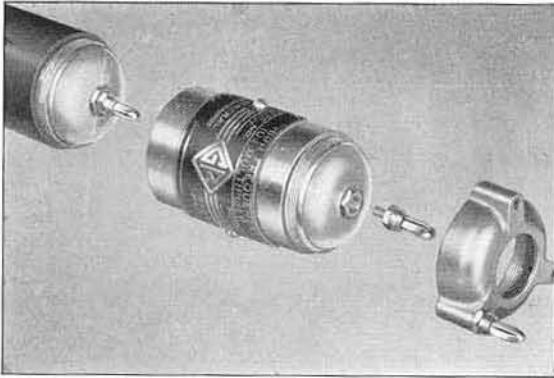

This multiplier extends the a-c voltage range of the TYPE 1800-A Vacuum-Tube Voltmeter to 1500 volts. It consists of a capacitive voltage divider which provides a ten-to-one reduction between the voltage applied to the multiplier and the voltage appearing across the voltmeter terminals. The multiplier screws onto the end of the voltmeter probe, adding about two inches to its length.

SPECIFICATIONS

Multiplier Ratio: 10 : 1 ± 1 per cent, when the multiplier is adjusted to the voltmeter with which it is to be used. A multiplier ordered with a TYPE 1800-A Voltmeter is adjusted to that voltmeter. When the multiplier is used with another voltmeter, there is a possible ad-

ditional error of ± 2 per cent, but the multiplier can be adjusted to any TYPE 1800-A voltmeter by the user.

Input Impedance: The equivalent parallel resistance is of the order of one hundred times the equivalent parallel resistance of the voltmeter probe. The equivalent parallel capacitance is 1.5 μf . The probe cap and a center plug when screwed on the multiplier add approximately 0.5 μf .

Frequency Error: The multiplier frequency error is shown in the plot. The resonant frequency of the multiplier and voltmeter probe together is approximately 1050 Mc, the same as the resonant frequency of the probe alone. Thus the high-frequency error can be determined from the correction curves furnished with the voltmeter. Only the curves for indicated voltages of 15 volts and higher need be used because the multiplier is not needed for measurement of voltages below 150 volts. The multiplier is not recommended for use at frequencies below 100 kc.

Dimensions: (Length) 2 $\frac{5}{8}$ x (diameter) 1 $\frac{5}{8}$ inches, over-all.

Net Weight: 4 ounces.

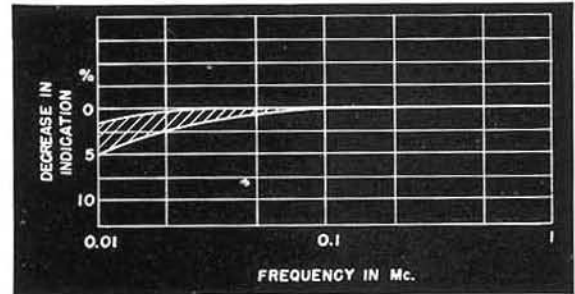

| Type | Code Word | Price |
|--------------------------|-----------|---------|
| 1800-P2 Multiplier | ABODE | \$18.00 |

TYPE 726-P1 MULTIPLIER

The TYPE 726-P1 Multiplier was designed for use with the TYPE 726-A Vacuum-Tube Voltmeter (now discontinued) to extend the

range of voltage measurements up to 1500 volts. A limited quantity of these multipliers is still available.

| Type | Code Word | Price |
|-------------------------|-----------|---------|
| 726-P1 Multiplier | ALoud | \$14.00 |

TYPE 727-A VACUUM-TUBE VOLTMETER

(BATTERY OPERATED)

USES: This is a general-purpose vacuum-tube voltmeter for use at frequencies up to about 100 megacycles. Because it is battery operated and portable, it has many applications in the field, where an a-c power line is not always available.

DESCRIPTION: A diode rectifier circuit is employed as in the TYPE 1800-A Voltmeter but with a more sensitive two-stage d-c amplifier, permitting the measurement of a-c voltages

down to 50 millivolts over the entire frequency range. The high-voltage limit is also extended, to 300 volts.

FEATURES: The high input impedance, wide voltage range, and wide frequency range of this instrument combined with its convenience and portability make the TYPE 727-A Vacuum-Tube Voltmeter an extremely useful meter for the communications laboratory, as well as for field work.



SPECIFICATIONS

Range: 0.05 volt to 300 volts a-c, in seven ranges (0.3, 1, 3, 10, 30, 100, 300 volts, full scale).

Accuracy: With sinusoidal voltages applied, the accuracy is $\pm 3\%$ of full scale on the 0.3-volt range and $\pm 2\%$ of full scale on all other ranges. An additional error of $\pm 3\%$ of indicated voltage may eventually occur on the 30-, 100-, and 300-volt ranges, because of long-period aging of the divider resistors. If the full-scale sensitivity is checked occasionally, correction can then be made to eliminate the effect of any such aging.

Waveform Error: The instrument is calibrated to read the r-m-s value of a sinusoidal voltage. On the higher voltage ranges, however, it is essentially a peak reading device, calibrated to read 0.707 of the peak value of the applied voltage, and on distorted waveforms the percentage deviation of the reading from the r-m-s value may be as large as the percentage of harmonics present. On the lower ranges the instrument approximates a true square-law device.

Frequency Error: Less than 1% between 20 cycles and 30 Mc. At higher frequencies, the error is about +5% at 65 Mc and about +10% at 100 Mc.

Input Impedance: The input capacitance is approximately 16 μmf . The parallel input resistance (at low frequencies) is about 5 megohms on the lower ranges and about 3 megohms on the 30-, 100-, and 300-volt ranges. The accompanying curves give the variation of R_p and X_p with frequency.

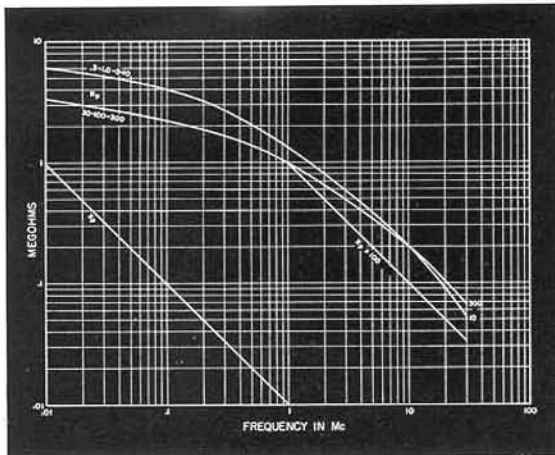

Plot of resistive and reactive components of input impedance of TYPE 727-A Vacuum-Tube Voltmeter.

Temperature and Humidity Effects: Over the normal range of room conditions (65° Fahrenheit to 95° Fahrenheit; 0 to 95% relative humidity) the accuracy of indication is substantially independent of temperature and humidity conditions. Somewhat reduced accuracy may be expected, however, if the instrument is subjected to extremes of temperature.

Zero Adjustment: A zero adjustment is provided on the panel. The setting is the same for all ranges.

Vacuum Tubes: Two 185 tubes and one 957 tube are used and are supplied with the instrument.

Batteries: Two Burgess W20P1, one Burgess W5BP, and three Burgess 2F batteries are required, and are supplied with the instrument. Battery life is approximately 250 hours of intermittent operation.

Mounting: The instrument is supplied in a walnut case with cover and is mounted on an engraved black crackle-finish aluminum panel.

Dimensions: 11 x 6 5/8 x 5 3/8 inches, over-all (cover closed).

Net Weight: 10 7/8 pounds, including batteries.

Type

Code Word

Price

727-A

Vacuum-Tube Voltmeter

PIGMY

\$180.00

PATENT NOTICE. See Note 28, page vi.

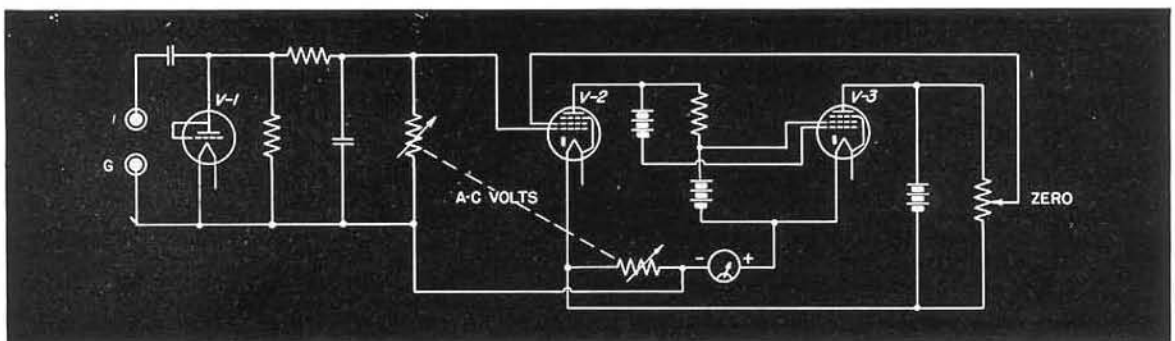

TYPE 728-A VACUUM-TUBE VOLTMETER (BATTERY OPERATED)

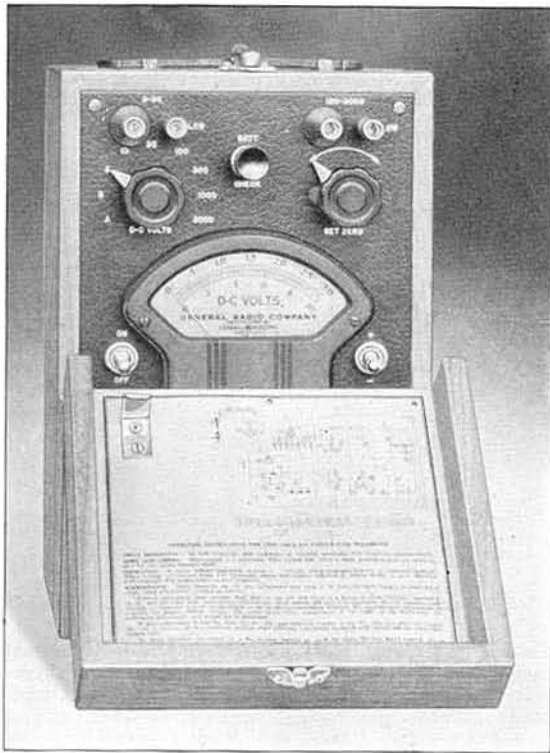

USES: This voltmeter is intended for measuring d-c voltages in low-power circuits where no appreciable power can be taken by the meter. It is particularly useful for measuring electrode voltages on vacuum tubes and cathode-ray oscillographs.

DESCRIPTION: The circuit is that of a degenerative d-c amplifier. The voltage to be measured is applied directly to the grid on the lower ranges, and through a high resistance voltage divider for the high ranges. The instrument is portable and power supply is obtained from self-contained batteries.

FEATURES: ▶ Extremely high input resistance, greater than 1000 megohms, is available on all ranges.

▶ Superimposed a-c voltages of considerable magnitude have no effect on the meter indication, thus making possible the measurement of fixed electrode voltages in the presence of signal voltages.

▶ Either the positive or the negative terminal of the source under measurement can be grounded to the panel by the use of the reversing switch provided on the panel.

SPECIFICATIONS

Range: 0.05 to 3000 volts in seven ranges (3, 10, 30, 100, 300, 1000, 3000 volts, full scale).

Accuracy: Within $\pm 3\%$ of full scale on all ranges. An additional error of $\pm 3\%$ of the indicated voltage may eventually occur on the 100-, 300-, 1000- and 3000-volt ranges because of long-period aging of the divider resistors. The effect of such aging can be eliminated if the full-scale sensitivity is checked occasionally, and any necessary corrections made. Battery aging can cause an additional error of 2% of full scale on the 3-volt range.

Input Resistance: 1000 megohms on the higher voltage ranges (100, 300, 1000, 3000 volts, full scale). Greater than 5000 megohms on the low voltage ranges.

Terminals: Two sets of input terminals are provided on the panel. One set is used for measurements at the low voltage end of the range (0 to 30 volts) and the other set is used for the higher voltage measurements (30 to 3000 volts).

Polarity: A reversing switch on the panel permits measurements with either the positive or the negative terminal of the source grounded to the panel of the instrument.

Effect of AC: Superimposed a-c voltages of less than 200 volts have a negligible effect on the meter indication.

Tube: The tube, a 1L4, is supplied.

Batteries: The batteries required are three Burgess W30BPX or equivalent and one Burgess F2BP or equivalent. A compartment is provided in the case of the instrument for holding all batteries. A set of batteries is supplied with the instrument.

Mounting: The instrument is supplied in a walnut case with cover and is mounted on an engraved black crackle-finish aluminum panel.

Dimensions: With cover closed, (length) 11 x (width) $6\frac{5}{8}$ x (height) $5\frac{7}{8}$ inches, over-all.

Net Weight: $9\frac{3}{4}$ pounds, including batteries.

| <i>Type</i> | <i>Code Word</i> | <i>Price</i> |
|--|------------------|-----------------|
| 728-A D-C Vacuum-Tube Voltmeter | PILOT | \$155.00 |

Elementary schematic diagram for TYPE 728-A D-C Vacuum-Tube Voltmeter.

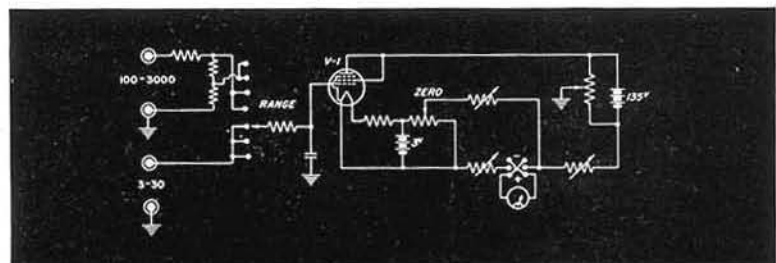

TYPE 729-A MEGOHMMETER (BATTERY OPERATED)

USES: This megohmmeter is a battery-operated design particularly intended for applications where portability is required. It is well adapted for field use in the measurement of the leakage resistance of cables and insulation. The wide range of resistance covered by this instrument makes it suitable for use as a moisture content indicator for such materials as lumber, paper, and leather, where a definite relationship exists between moisture content and electrical conductivity.

DESCRIPTION: The circuit employed is that of a conventional ohmmeter. The necessary sensitivity for measuring high resistance is obtained by using a vacuum-tube voltmeter as the indicating element.

The highest resistance standard (1000 megohms) is especially treated to prevent surface leakage. This treatment insures that the readings of the instrument are essentially independent of humidity.

FEATURES: ▶ A very wide range of resistance values can be measured simply and quickly with the TYPE 729-A Megohmmeter.

▶ Good accuracy is obtained, and the circuit used is so stabilized that the accuracy of calibration is maintained independent of tube characteristics.

▶ Treatment of the high-resistance standard to prevent surface leakage eliminates difficulties normally caused by high humidity.



▶ This megohmmeter is particularly valuable for field applications because of its small size and self-contained power supply.

SPECIFICATIONS

Range: 2000 ohms to 50,000 megohms in five overlapping ranges.

Scale: The standard direct-reading ohmmeter calibration is used: center scale values are 0.1, 1, 10, 100, and 1000 megohms. Length of scale, 3 1/4 inches; central decade, 1 5/8 inches.

Accuracy: Within $\pm 5\%$ of the indicated value between 30,000 ohms and 3 megohms, and within $\pm 8\%$ of the indicated value between 3 megohms and 3000 megohms when the central decade of the scale is used. Outside the central decade the error increases because of the compressed scale.

Temperature and Humidity Effects: Over the normal range of room conditions (65° Fahrenheit to 95° Fahrenheit; 0 to 95% relative humidity) the accuracy of indication is substantially independent of temperature and humidity conditions. Somewhat reduced accuracy may be expected, however, if the instrument is subjected to temperatures beyond the above range.

Voltage on Unknown: The voltage applied on the unknown does not exceed $22\frac{1}{2}$ volts and varies with the meter indication.

Tube: The tube, a 1L4, is supplied.

Batteries: The batteries required are two Burgess W30BPX or equivalent and one Burgess 2F2H or equivalent. A compartment is provided in the case of the instrument for holding all batteries, and a set of batteries is supplied with the instrument. Battery life is approximately 250 hours of intermittent operation.

Mounting: The instrument is supplied in a walnut case with cover and is mounted on an engraved black crackle-finish aluminum panel.

Dimensions: With cover closed: (Length) 11 x (width) 6 1/2 x (height) 5 7/8 inches, over-all.

Net Weight: 8 1/4 pounds, including batteries.

| Type | Code Word | Price |
|---------------------------|-----------|----------|
| 729-A Megohmmeter | PIOUS | \$105.00 |

TYPE 1861-A MEGOHMMETER AND VOLTMETER

(A - C OPERATED)



USES: The TYPE 1861-A Megohmmeter is a direct-reading ohmmeter for measuring relatively high resistances, including the leakage resistance of cables and samples of insulating material, and the resistance of all types of fixed and variable resistors. It can also be used to locate defective insulation in electrical equipment, and its wide range makes it particularly suitable for the determination of the moisture content of wood, paper, and dehydrated products.

The leakage resistance of capacitors can also be measured, but in measuring large capacitors with low leakage, the time constant results in equilibrium being reached slowly. For example, a 1- μ f capacitor, having a leakage resistance of 1000 megohms, could be shown in a few seconds to have a resistance greater than 500 megohms, but perhaps a minute would be required to obtain the resistance within 10%. If a higher, or constant, test voltage or a lower time constant is required, the TYPE 544-B Megohm Bridge is recommended (see page 88).

This instrument can also be used as a vacuum-tube voltmeter for measuring d-c voltage up to 100 volts.

DESCRIPTION: This instrument is very similar to the ordinary ohmmeter, except that, in order to measure very high resistances, a vacuum-tube voltmeter is used instead of the conventional indicator. A zero adjustment is provided for setting all five ranges in a single operation.

FEATURES: ▶ Resistance is read directly from a large meter scale.

▶ Operation is as simple as that of an ordinary ohmmeter, and a wide range of resistances can be measured on the five overlapping ranges.

▶ Readings are independent of supply voltage fluctuations because the a-c power supply is regulated.

▶ D-c voltages up to 100 volts can also be measured with this megohmmeter.

SPECIFICATIONS

Range: 2000 ohms to 50,000 megohms in five overlapping ranges; zero to 100 volts, d-c.

Scale: The standard direct-reading ohmmeter calibration is used; center scale values are 0.1, 1, 10, 100, and 1000 megohms. Length of scale, 3 1/4 inches; center decade, 1 5/8 inches. The scale is illuminated by a lamp in the indicating meter. The voltage scale is linear.

Accuracy: Within $\pm 5\%$ of the indicated value between 30,000 ohms and 3 megohms, and within $\pm 8\%$ of the indicated value between 3 megohms and 3000 megohms when the central decade of the scale is used. Outside the central decade the error increases because of the compressed scale. For voltage measurements the accuracy is $\pm 2\%$ of full scale.

Input Resistance: For voltage measurements the input resistance in megohms is indicated by the selector switch. On the ∞ position the equivalent resistance is greater than 20,000 megohms.

Temperature and Humidity Effects: Over the normal

range of room conditions (65° Fahrenheit to 95° Fahrenheit; 0 to 95% relative humidity) the accuracy of the instrument is substantially independent of temperature and humidity.

Voltage on Unknown: The applied voltage on the unknown does not exceed 106 volts and varies with the indication.

Tubes: The necessary tubes, one 6X5-GT/G, one 85 and one 0C3/VR105, are supplied.

Power Supply: 105 to 125 (or 210 to 250) volts, 40 to 60 cycles. The power required is 10 watts.

Accessories Supplied: A line connector cord.

Mounting: The instrument is supplied in a walnut case and is mounted on an engraved black crackle-finish aluminum panel.

Dimensions: (Width) 10 x (height) 8 x (depth) 5 1/2 inches, over-all.

Net Weight: 8 1/2 pounds.

| Type | Code Word | Price |
|--------------------|-----------|----------|
| 1861-A Megohmmeter | ONION | \$130.00 |



TYPE 483-F OUTPUT METER

USES: The TYPE 483-F Output Meter finds its greatest usefulness in the routine laboratory measurements of voltages at audio frequencies and for comparison measurements of various types, where the meter is used to match two voltages.

When used in conjunction with an amplifier this meter is an excellent bridge null detector for power and audio frequencies.

DESCRIPTION: A copper-oxide-rectifier voltmeter is used as the indicating meter. An L-type multiplying network is used to extend the range and to furnish a constant input impedance.

FEATURES: The TYPE 483-F is a sensitive, wide-range, constant-impedance, and rugged output meter.

SPECIFICATIONS

Voltage Range: Below 0.5 volt to 200 volts in seven ranges (2, 4, 10, 20, 40, 100, 200 volts, full scale).

Accuracy: The fundamental accuracy is $\pm 5\%$ of full scale, which is equivalent to 0.1 volt multiplied by the multiplier setting. This accuracy applies only when the instrument is operated on sinusoidal voltages and on the flat portions of the characteristic curves shown below.

Waveform Error: The copper-oxide rectifier-type meter is calibrated in r-m-s values for a sinusoidal applied voltage. When non-sinusoidal voltages are applied, an error in indication can occur, since the meter is not a true r-m-s indicating device. The error will depend on the magnitude and phase of the harmonics present, but with waveforms normally encountered in communications work, will not be serious.

Input Impedance: The impedance on the 100 multiplier is 20,000 ohms $\pm 2\%$. For lower multiplier settings, however, the impedance varies slightly with voltage. The greatest change in impedance occurs on the 1 multiplier where the impedance increases by approximately 15% as the voltage is dropped from full scale, 2 volts, to quarter scale, 0.5 volt.

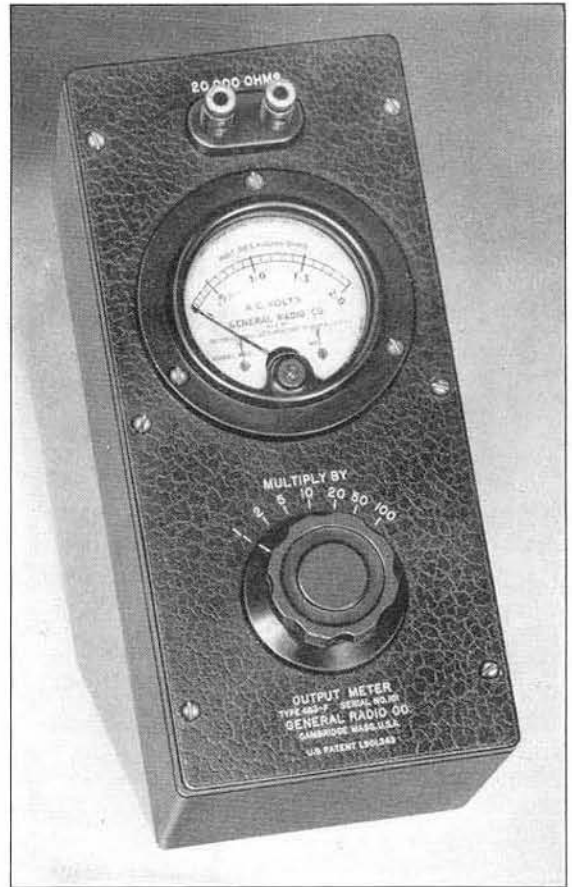

Scale Length: 2½ inches.

Terminals: Jack-top binding posts are provided. Standard ¼-inch spacing is used.

Mounting: Mounted on an aluminum panel which is mounted in a walnut cabinet.

Dimensions: (Length) 9¾ x (width) 4¼ x (height) 5¼ inches, over-all.

Net Weight: 3½ pounds.

| Type | Code Word | Price |
|--------------------|-----------|---------|
| 483-F Output Meter | AVOID | \$70.00 |

PATENT NOTICE. See Note 5, page vi.

(Left) Plot showing the effect of temperature on the meter indication. Note that in the normal room temperature range the temperature coefficient is practically zero. Data plotted here are the average from a number of instruments.

(Right) Average frequency characteristic of the meter.

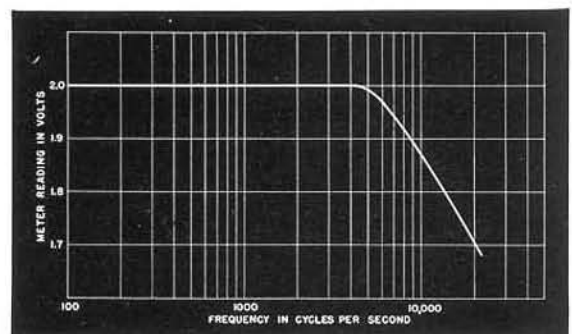
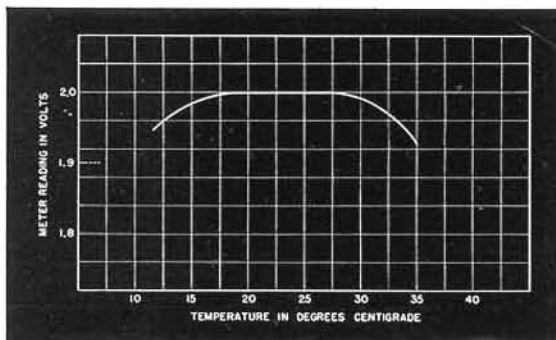

METERS

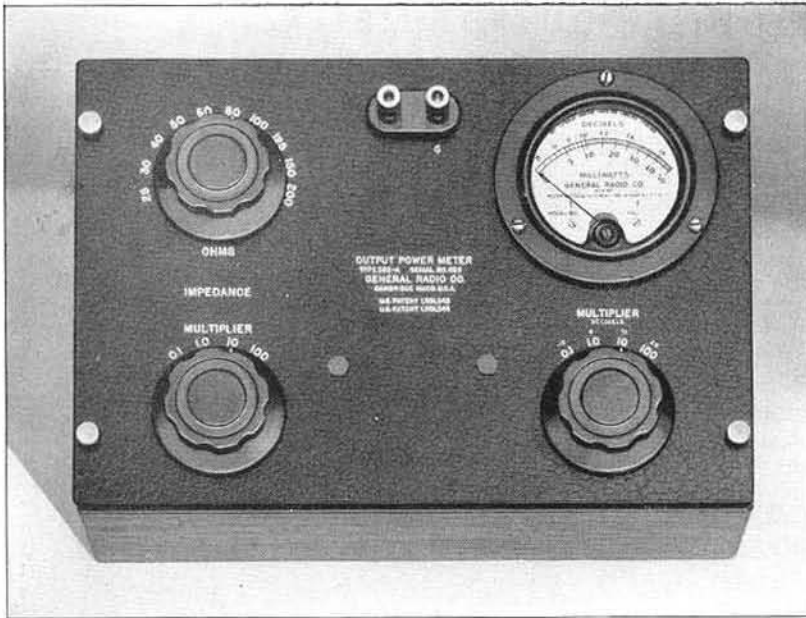

TYPE 583-A OUTPUT-POWER METER

USES: The output-power meter reads directly the amount of audio-frequency power that a source is capable of delivering into any desired load. Thus the effect of load impedance on power delivered can be easily measured, and the characteristic impedance of telephone lines, phonograph pickups, oscillators, and similar equipment can be found by observing the impedance which gives the maximum reading on the instrument.

In testing radio receivers the TYPE 583-A Output-Power Meter is very useful as an output indicator for standard selectivity, sensitivity, band-width, and fidelity tests, and an auxiliary decibel scale is furnished on the meter for this purpose.

DESCRIPTION: This instrument may be considered to be an adjustable load impedance across which is connected a voltmeter that is calibrated directly in watts lost in the load. Actually the input is connected through a multitap transformer and a resistance network to an output meter.

FEATURES: ▶ The power range covered is 50,000 : 1 and the impedance range 8000 : 1.

▶ All readings can be made directly and quickly.

▶ Considerable overloads, for short periods of time, can be handled by the rectifier-type voltmeter used as the indicating element.

SPECIFICATIONS

Power Range: 0.1 to 5000 milliwatts in four ranges (5, 50, 500, 5000 milliwatts, full scale). The copper-oxide meter is calibrated from 1 to 50 milliwatts with an auxiliary scale reading from 0 to 17 decibels above a reference level of 1 milliwatt. With the multiplier the total range is -10 to +37 decibels above 1 milliwatt.

Impedance Range: 2.5 to 20,000 ohms. Forty discrete impedances, distributed approximately logarithmically, are obtained by means of a ten-step OHMS dial and a four-step MULTIPLIER.

Accuracy: The accuracy of both power and impedance measurements varies with frequency. The maximum error in full-scale power reading does not exceed 0.5 decibel between 150 and 2500 cycles, nor does it exceed 1.5 decibels at 20 and 10,000 cycles. The average error is 0.3 decibel at 30 and 5000 cycles, and 0.6 decibel at 20 and 10,000 cycles.

The maximum error in impedance does not exceed 7% between 150 and 3000 cycles, nor does it exceed 50% at 20 and 10,000 cycles. The average error is 8% at 30 and 5000 cycles and 20% at 20 and 10,000 cycles.

Waveform Error: The indicating instrument used is a

copper-oxide rectifier-type meter, calibrated in r-m-s values for a sinusoidal applied voltage. When non-sinusoidal voltages are applied, an error in indication can occur, since the meter is not a true r-m-s indicating device. The error will depend on the magnitude and phase of the harmonics present, but with waveforms normally encountered in communications work, will not be serious.

Mounting: The instrument is mounted on an aluminum panel in a walnut cabinet.

Dimensions: (Length) 10 x (width) 7 x (height) 6 inches, over-all.

Net Weight: 8¼ pounds.

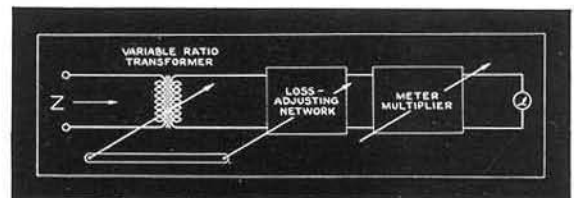

| Type | Code Word | Price |
|--------------------------------|-----------|----------|
| 583-A Output-Power Meter | ABUSE | \$120.00 |

PATENT NOTICE. See Notes 5, 6, page vi.



TYPE 783-A OUTPUT-POWER METER

USES: The TYPE 783-A Output-Power Meter is a direct-reading instrument for measuring the power output of audio-frequency circuits.

Some of its specific uses include the testing of amplifiers, transformers, and other networks. It is particularly useful for simulating loud-speaker or other load impedances in testing the output characteristics of high-power audio systems, since it will measure power outputs as high as 100 watts. It is sufficiently sensitive, on the other hand, to be useful for measurements on very low-level circuits.

DESCRIPTION: Functionally the TYPE 783-A Output-Power Meter is equivalent to an adjustable load impedance across which is connected a voltmeter that is calibrated directly in watts dissipated in the load.

FEATURES: ▶ A power range extending to 100 watts is provided by this meter.
 ▶ Frequency and impedance characteristics are improved over those of the smaller TYPE 583-A Output-Power Meter.
 ▶ The auxiliary decibel scale is a convenience for many types of measurements.

SPECIFICATIONS

Power Range: 0.2 milliwatt to 100 watts in five ranges (10 and 100 milliwatts, 1, 10, and 100 watts, full scale). An auxiliary decibel scale on the meter reads from -10 to $+10$ decibels above a reference level of 1 milliwatt. With the multiplier the total range is -10 to $+50$ decibels above 1 milliwatt.

Impedance Range: 2.5 to 20,000 ohms. Forty discrete impedances, distributed approximately logarithmically, are obtained by means of a ten-step OHMS dial and a four-step MULTIPLIER.

Impedance Accuracy: The input impedance is within $\pm 2\%$ of the indicated value, except at the higher audio frequencies, where the error for the higher impedance settings may exceed this value. At 15,000 cycles the input impedance error is about 5% for impedances from 10,000 to 20,000 ohms.

Power Accuracy: The indicated power is accurate to ± 0.25 db at full-scale reading. At the lowest impedance multiplier setting (2.5 to 20 ohms) there may be an additional error of 0.2 db due to switch contact resistance when the power multiplier is set at 10 (10 to 100 watt range).

The over-all frequency characteristic of the power indication is flat within ± 0.5 db from 20 cycles to 10,000 cycles; within ± 0.75 db to 15,000 cycles.

Waveform Error: The indicating instrument used is a copper-oxide rectifier meter, calibrated in r-m-s values for a sinusoidal applied voltage. When non-sinusoidal voltages are applied, an error in indication can occur, since the meter is not a true r-m-s indicating device.

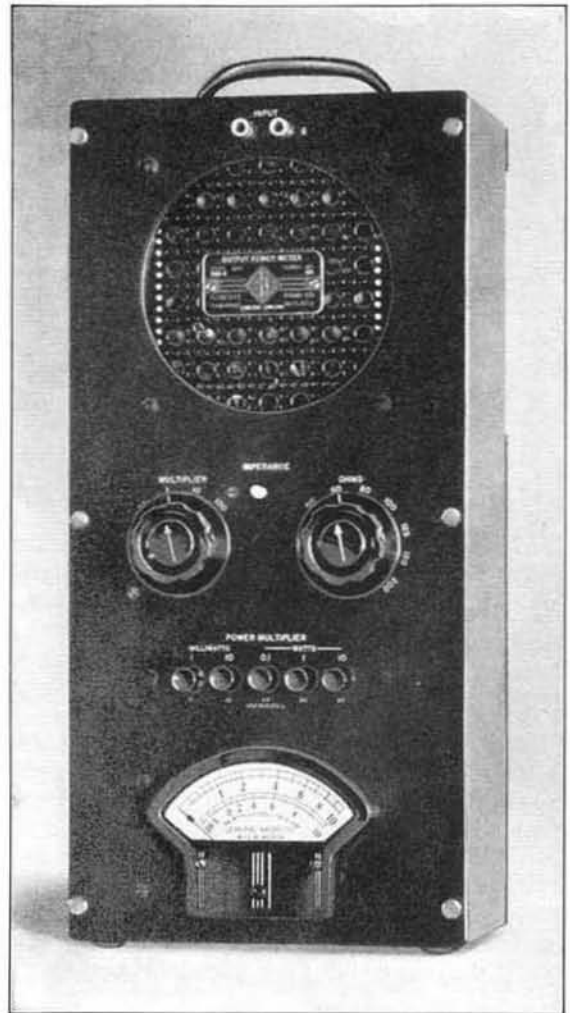

The error will depend on the magnitude and phase of the harmonics present, but, with waveforms normally encountered in measurement circuits at communications frequencies, will not be serious.

Temperature and Humidity Effects: Humidity conditions have a negligible effect on the accuracy of the instrument.

The instrument is calibrated at 77° Fahrenheit and, if the ambient temperature departs widely from this value, additional errors of indication may be expected. At high temperatures (95° Fahrenheit) this additional error may approach the nominal calibration error, particularly at the higher frequencies.

The instrument is so designed that the heat dissipated by the instrument itself has a negligible effect on the accuracy.

Mounting: The instrument is mounted on a phenolic panel in a walnut cabinet.

Dimensions: 8 x 18 x 7 inches, over-all.

Net Weight: 17 pounds.

| Type | Code Word | Price |
|--------------------------------|-----------|----------|
| 783-A Output-Power Meter | ABBEY | \$260.00 |

PATENT NOTICE. See Notes 5, 6, page vi.

TYPE 1500-A COUNTING RATE METER



USES: The Counting Rate Meter with its Geiger-Mueller counter is a complete instrument for measuring the rate of random emanations from radio-active materials. As such, it is a basic tool in nuclear physics, where applications are developing rapidly in many scientific and industrial fields.

Two familiar applications are the quantitative measurement of radio-active materials in hospitals, and cosmic ray research. A most promising field is in conjunction with radio-active isotopes, several hundred of which are now being produced in relatively large quantities. The radio-activity of such isotopes provides a tracer by means of which their course in chemical and physical processes

View of Pre-amplifier with cover removed to show Beta-Ray Counter which has a foil window made of 0.001-inch aluminum alloy. Note the convenient arrangement for plugging counters in or out of the circuit.

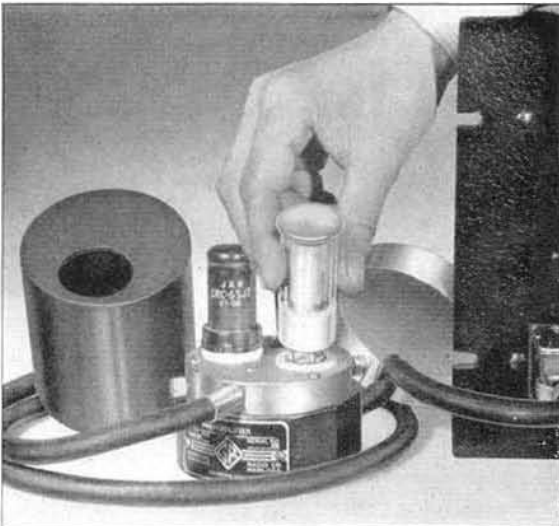

can be followed with the counter. The present applications of this technique include problems in medicine, chemistry, geology, metallurgy and agriculture.

DESCRIPTION: The counting rate meter consists of a probe containing a quenching pre-amplifier and a socket in which the counter tube is normally mounted, a second amplifier, a circuit which standardizes the shape of the pulses without affecting their number, an amplifier to charge a shunted capacitor, and a vacuum-tube voltmeter which measures the charge. This charge is proportional to the rate of emanations, and the indicating element is calibrated directly in counts per minute. This rate may also be simultaneously recorded on a pen and ink recorder. Five ranges are provided, and the total range of indication is from 5 to 20,000 counts per minute. The internal power supply system operates from the a-c line, and adequate voltage regulation is provided.

FEATURES: ▶ A continuous indication of counting rate is given by the TYPE 1500-A Counting Rate Meter.

▶ A 5-milliampererecorder can be connected directly to a panel jack to give a continuous record of counting rate as indicated by the meter.

▶ The output of the trigger circuit is available at terminals at the rear of the instrument to operate an integrating register, if desired.

▶ The counter is so made that it can be plugged in and out of a socket in the same manner as an ordinary vacuum tube. Changing or replacing counter tubes is thus greatly facilitated.

- ▶ A loudspeaker is mounted on the panel to provide an audible monitor.
- ▶ The high-voltage supply for the counter circuit is well regulated and is continuously

adjustable from 400 to 2000 volts, so there is no difficulty in operating the counter on the plateau of its characteristic. This voltage is also available at terminals at the rear.

SPECIFICATIONS

Range: Full scale values of 200, 600, 2000, 6000, and 20,000 counts per minute are provided. The minimum rate that can be read on the meter scale is 5 counts per minute.

Accuracy: The instrument has been calibrated with a generator of equally-spaced pulses to yield an accuracy of $\pm 3\%$ of full scale on all ranges.

The resolving time of the instrument is adequate for random counts up to 20,000 per minute.

Counter Tube: No counter tube is supplied with the instrument but non-self-quenching beta- and gamma-ray Geiger-Mueller counters are available as shown in the price list below. An alpha-ray counter can also be used with the instrument if desired. The counter is mounted in the probe, which is supplied with the instrument, and replacement is simple.

Counter Circuit Voltage: The voltage applied to the counter circuit is continuously adjustable from 400 to 2000 volts. The value of the voltage is read from an eight-position switch and a calibrated dial which covers the 200-volt interval between switch points. Means is provided for standardizing the voltage so that the accuracy of the voltage readings is within $\pm 3\%$ of the actual value. The power supply is well regulated so that line-voltage fluctuations do not cause changes in the high-voltage supply.

Output: The output of the trigger circuit is available at terminals at the rear of the instrument. The 400-

2000-volt variable high-voltage supply is also available at the rear of the instrument.

Recorder: A panel jack is provided for connecting a 5-ma recorder into the meter circuit.

Aural Monitor: A small loudspeaker is mounted on the panel for use as an aural monitor. A control, with an off position, is provided for adjusting the volume.

Power Supply: 105 to 125 volts, 50 to 60 cycles. By a simple change in connections on the power transformer, a 210- to 250-volt line can be used.

Power Input: 60 watts.

Accessories Supplied: Plug for connecting recorder, and line connector cord.

Accessories Required: A counter tube must be obtained separately (see price list below).

Vacuum Tubes:

- | | |
|------------|-------------|
| 5-6SJ7 | 2-6J5 |
| 1-6AG7 | 1-6C6 |
| 1-6X5-GT/G | 2-991 |
| 1-2X2/879 | 2-0C3/VR105 |

All are supplied.

Mounting: The instrument is shipped with walnut end frames for table mounting. Relay-rack mounting is possible by removing the end frames.

Dimensions: Panel, 19 x 8 1/4 inches; depth behind panel, 13 inches.

Net Weight: 38 1/2 pounds.

| Type | Code Word | Price |
|---------|-----------------------------|------------------|
| *1500-A | Counting Rate Meter..... | WORRY |
| 1500-P2 | Beta-Ray Counter Tube..... | WORRYBETAR |
| 1500-P3 | Gamma-Ray Counter Tube..... | WORRYGAMMA |
| | | \$495.00 |
| | | Price on Request |
| | | Price on Request |

*Without Counter Tube

PATENT NOTICE, See Note 30, page vi.

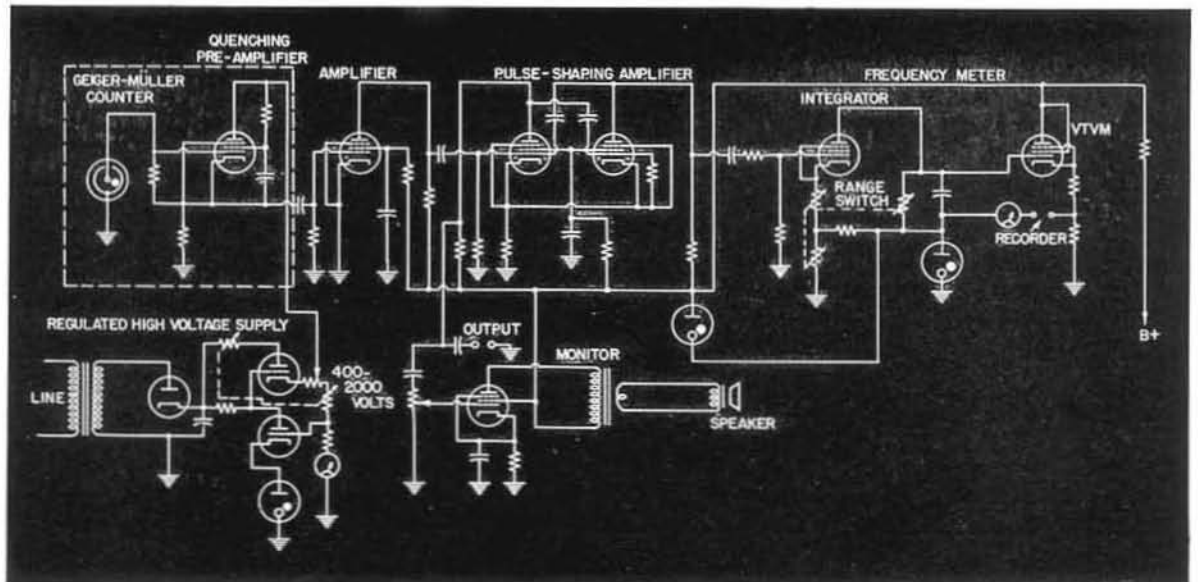

METERS

TYPE 546-C AUDIO-FREQUENCY MICROVOLTER

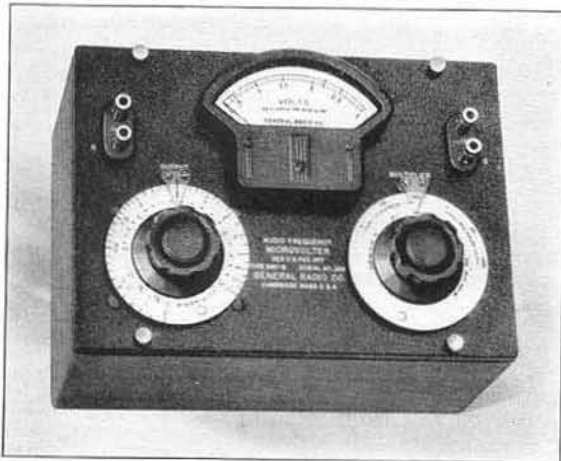

Illustration shows older model, TYPE 546-B

USES: The TYPE 546-C Audio-Frequency Microvolter is a useful source of small, known, audio-frequency voltages. In measuring the response of amplifiers, transformers, and other audio equipment, such a source of known input voltage is extremely valuable. The microvolter can also be used to measure other small voltages by substitution methods.

SPECIFICATIONS

Output Voltage Range: From 0.1 microvolt to 1.0 volt open circuit, when the input voltage is set to the standardized reference value.

Accuracy: For open-circuit output voltages the calibration is accurate within $\pm(3\% + 0.5 \text{ microvolt})$ for output settings above 1 microvolt and for all frequencies between 20 and 20,000 cycles. For higher frequencies up to 100 kc the calibration is accurate within $\pm 5\%$ for output settings above 100 microvolts. These specifications apply only where waveform and temperature errors are negligible (see below).

In calculating ratios of output voltages, at a given frequency, the accuracy of any given reading can be considered to be within $\pm(2\% + 0.5 \text{ microvolt})$, at frequencies up to 100,000 cycles. At the higher frequencies this accuracy applies only at levels above 100 microvolts.

The microvolter can be used on dc if an external meter is used or if the internal meter has been calibrated for dc.

Output Impedance: The output impedance is approximately 600 ohms and is constant with setting within $\pm 5\%$. This impedance is sufficiently low so that no correction on the output voltage is necessary for load impedances of the order of 100,000 ohms and greater.

Input Impedance: Approximately 600 ohms, substantially independent of output setting on all but the highest multiplier position.

Waveform Error: The accuracy of the microvolter as a calibrated attenuator or voltage divider is independent of waveform. The absolute accuracy of the output voltage calibration depends on the characteristics of the input copper-oxide rectifier voltmeter, which has a small waveform error that depends in turn on both the phase and the magnitude of harmonics present in the input.

DESCRIPTION: This instrument consists, essentially, of a constant impedance attenuator and a voltmeter by means of which the input to the attenuator is standardized. A switch controls the output voltage in decade steps while an individually calibrated dial provides continuous control over each decade.

FEATURES: ▶ An excellent frequency characteristic, extending from very low frequencies up to 100,000 cycles, is available in this instrument.

▶ Excellent accuracy is obtainable for absolute voltage levels as well as for voltage ratios, which are all that are needed in gain or loss measurements.

▶ Decibel scales, in addition to the voltage calibration of the meter and multipliers, are provided. These scales make it possible to obtain relative response characteristics in decibels without calculations.

This error in the voltmeter can, in general, be neglected when the microvolter is used with ordinary laboratory oscillators. The rectifier-type voltmeter itself introduces some distortion unless the source impedance is very low. With a 600-ohm source the distortion introduced is about 0.2%.

Temperature Error: The accuracy of the calibration is independent of temperature when the microvolter is used as an attenuator or voltage divider. The absolute accuracy is affected slightly by temperature because of change in the voltmeter characteristics. The necessary correction for temperatures from 65° to 95° Fahrenheit is furnished with the instrument. The effects of humidity are negligible.

Power Source: The driving oscillator must be capable of furnishing about 2.2 volts across 600 ohms, or about 8 milliwatts.

Terminals: Jack-top binding posts are mounted on standard $\frac{3}{4}$ -inch spacing.

Mounting: The instrument is mounted on an aluminum panel in a shielded walnut cabinet.

Dimensions: (Length) 10 x (width) 7 x (height) $6\frac{3}{8}$ inches, over-all.

Net Weight: $6\frac{1}{2}$ pounds.

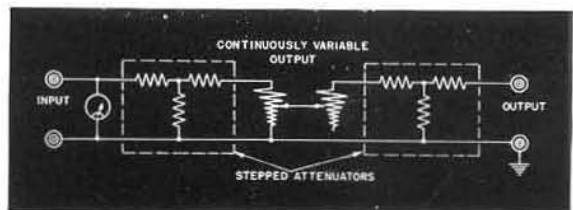

| Type | Code Word | Price |
|---|-----------|----------|
| 546-C Audio-Frequency Microvolter*..... | CROWN | \$110.00 |

*Reg. U. S. Pat. Off.



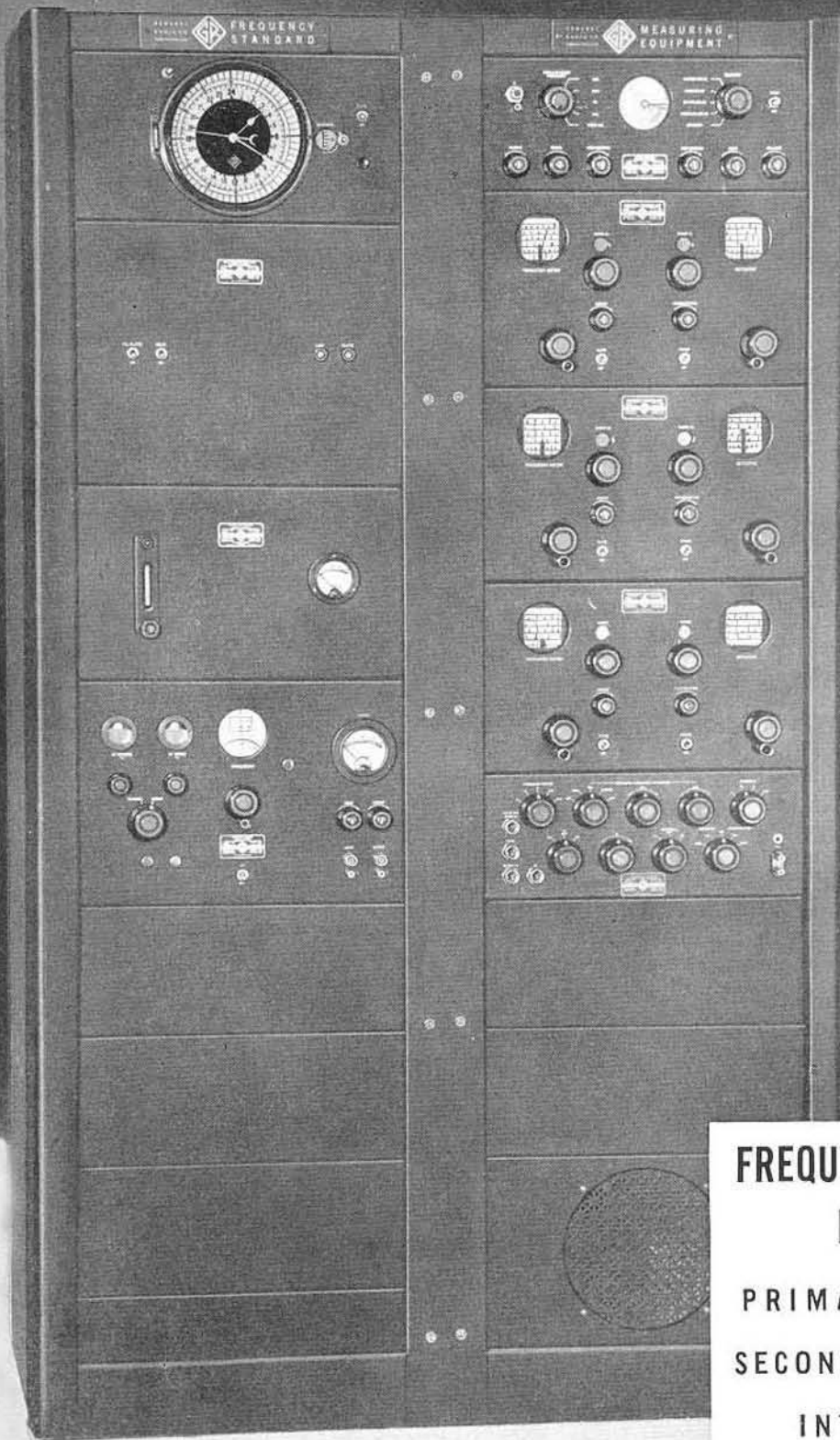

FREQUENCY-MEASURING EQUIPMENT

PRIMARY STANDARDS
•
SECONDARY STANDARDS

•
INTERPOLATION
EQUIPMENT

•
HETERODYNE
FREQUENCY METERS

•
FREQUENCY MONITORS

•
PRECISION FORKS

•
WAVEMETERS



FREQUENCY AND TIME

The determination of frequency directly in terms of time is a fundamental measurement; since frequency is the *time* rate of recurrence of a cyclical phenomenon. A *primary* standard of frequency is, therefore, defined as one whose frequency is determined directly in terms of time. A *secondary* standard is one whose frequency is determined by comparison with a primary standard, or by comparison with other secondary standards, some one of which was originally compared with a primary standard.

It is to be noted that the above classifications of frequency standards have nothing to do with the *accuracies* of the standards. In fact the same standard is logically classed as a primary standard if checked directly against time, and as a secondary standard if checked against standard frequency transmissions (representing a distant primary standard).

In practice, the responsibility of establishing and maintaining accurate time determinations by astronomical observations is not assumed by the individuals desiring a primary standard of frequency. The time determinations are carried out by observatories especially equipped for the purpose. The results are made available to a large number of users by radio and wire transmission. In the United States, the U. S. Naval Observatory transmits high-precision time signals by radio

through the facilities of the U. S. Naval Radio Service. Transmissions on several frequencies are available several times a day and can be received nearly all over the world.

The user of a primary frequency standard can then conveniently determine the frequency of the standard in terms of the standard time interval sent to him by radio. In the General Radio equipment means are provided for quickly and easily making this comparison. For the most precise results, the errors of the transmitted time signal must be taken into account. Correction data may be obtained by applying to the Superintendent, U. S. Naval Observatory, Washington, D. C.

Since the astronomical clocks now used at the Naval Observatory are piezo-electric oscillators, similar to those used in accurate frequency standards and since, through close cooperation of the U. S. Naval Observatory and the National Bureau of Standards, the piezo-electric oscillators of the latter's primary frequency standard are checked in the same way as the former's astronomical clocks, the comparison with time is, in effect, carried out by the observatory. The standard frequency transmissions sent out by the Bureau of Standards consequently represent a primary standard of high precision available to all who can receive the transmissions. Where such transmissions can be received, it is generally more convenient and much quicker to make the comparison by frequency than by time. For information and schedules of transmission of standard frequencies, apply to the Radio Division, Bureau of Standards, Department of Commerce, Washington, D. C.

Because of the vagaries of high frequency transmission, many users rely on checks against time as a reserve. They also use the primary standard as a high-precision clock for laboratory timing purposes.

As so far considered, the precision oscillator is a single-frequency device. For practical utility it is necessary to obtain from this single frequency many other frequencies, both above and below the standard frequency, for convenience in measurements. Since most of the precision oscillators operate in the region of 50 to 100 kc, it is necessary to divide the frequency to obtain a value such that an easily constructed synchronous motor can be used to count the number of cycles executed by the precision oscillator in a standard interval of time. For measurements of high radio frequen-

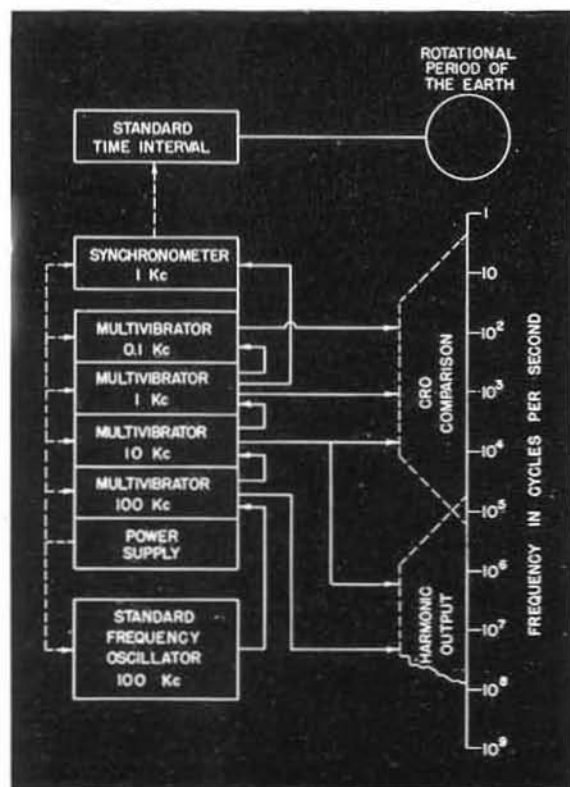

FIGURE 1. Block diagram showing the functional arrangement of the TYPE 1100-AP Primary Frequency Standard and the range of output frequencies available from it.

cies, it is necessary to multiply the standard frequency to obtain useful frequencies in the range of the frequency being measured. Both of these operations are readily performed by a controlled relaxation oscillator, known as a multivibrator.

An oscillator of this type is characterized by its susceptibility to control by an introduced voltage, the frequency of which lies near the fundamental, or low-order harmonic, frequency. In the controlled condition, the relaxation oscillator locks into step with the control voltage, and the frequency bears an integral relationship to the frequency of the controlling voltage.

**THE PRIMARY FREQUENCY STANDARD
TYPE 1100-AP**

The elements of a primary frequency standard, General Radio TYPE 1100-AP, are shown in Figure 1.

The frequency of the precision oscillator is 100 kc, which is divided successively by factors of 10 to obtain multivibrator fundamental frequencies of 10, 1, and 0.1 kc. A fourth multivibrator operating at a fundamental frequency of 100 kc, provides a large number of harmonics at 100 kc intervals for use at high radio frequencies. Harmonics of the 10 kc multivibrator are similarly used. In the audio-frequency and low-frequency range (up to one or two hundred kc) a cathode ray oscilloscope is used to obtain hundreds of known frequencies. This is simpler than trying to make use of harmonics of the low standard frequencies.

The range of useful output frequencies obtainable from the General Radio Primary (or Secondary) Frequency Standard is indicated in Figure 1. Complete specifications are given on pages 164 to 166.

This frequency standard is the result of many years of continuous development in the General Radio laboratories. The quartz bar (and mounting), the oscillator circuit, and the temperature-control system used in the standard make possible a stability of a few parts

FIGURE 2. View of the TYPE 1190-A Quartz Bar used in TYPE 1100-A Frequency Standard, with cover removed, showing the spring suspension.

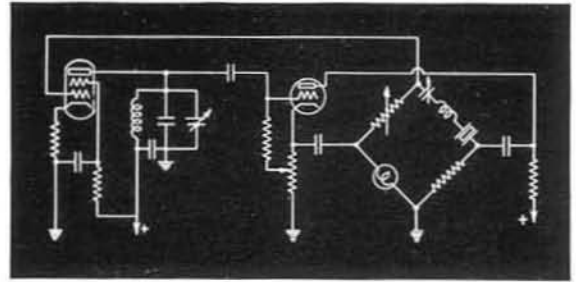
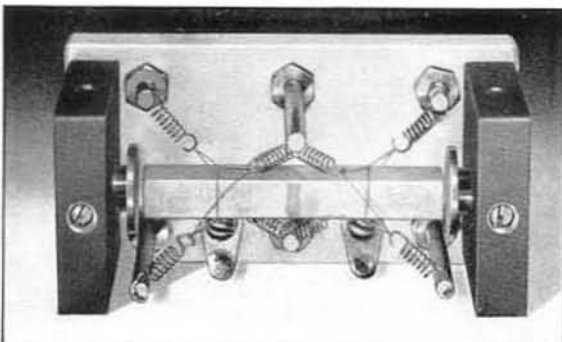

FIGURE 3. Elementary circuit of the bridge-type piezoelectric oscillator used in the TYPE 1100-A Frequency Standards.

in 10^8 over periods of several months, and a short-period stability of approximately 2 parts in 10^9 . The quartz bar and its mounting are shown in Figure 2. The bar vibrates in its second-harmonic extensional mode, and is held at its two nodes in a spring suspension mounting in such a manner as to introduce a minimum of damping. Electrodes are formed directly on the surfaces of the quartz. The cross-sectional dimensions of the bar have been so chosen that the temperature coefficient of frequency is zero in the vicinity of the operating temperature of 60°C .

The temperature-control system holds the temperature of the quartz bar constant to better than 0.01°C . The principles of operation of the temperature-control system were outlined in an article entitled "Notes on the Design of Temperature Control Units," by J. K. Clapp, *General Radio Experimenter*, August 1944.

A bridge-type oscillator circuit is used, shown in schematic form in Figure 3. In this circuit, the crystal vibrates at its series resonant frequency and the amplitude of oscillation is constant. For an analysis of the circuit, see J. K. Clapp, "A Bridge-Controlled Oscillator," *General Radio Experimenter*, April 1944, and May 1944.

**THE SECONDARY FREQUENCY STANDARD
TYPE 1100-AQ**

In the past there was a useful field for frequency standards of less than the best possible precision, such standards being checked frequently against standard frequency transmissions. These standards could be manufactured at a lower cost than the more precise standards and consequently were used in many applications where price was a governing consideration.

At present the demand for more accurate secondary standards, coupled with less expensive designs for primary standards, makes it undesirable to make two types of standard. Consequently, the same component units are offered for use as a secondary standard—the

FREQUENCY

precision oscillator, and multivibrator and power supply unit, but without the synchronometer unit. (This latter unit can be added later, if desired. All that is necessary is to mount it and plug in a cable supplied for the purpose.)

FREQUENCY MEASUREMENT

The next step, after establishing a series of standard frequencies embracing a portion of the frequency spectrum in which measurements of frequency are to be made, is to evaluate any unknown frequency in terms of one of the standard frequencies. Any unknown frequency will lie between two of the standard-frequency harmonics as shown in Figure 4. The simplest process is to determine the difference in frequency between the unknown frequency and the nearest of the standard frequencies. This difference is added to the standard frequency if the unknown lies above the standard, or subtracted if the unknown lies below the standard frequency.

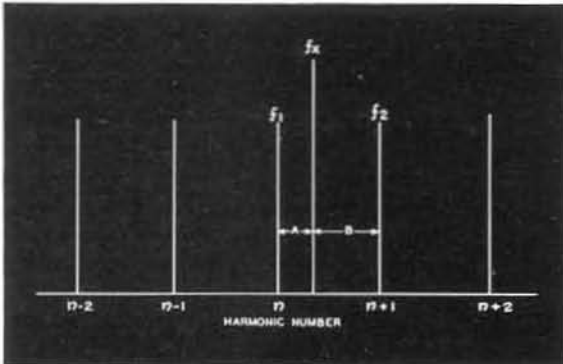

FIGURE 4. This diagram shows the relation between an unknown frequency and a standard harmonic series.

For evaluating the frequency difference, *A* or *B*, (Figure 4) a convenient method consists of beating the standard and unknown frequencies in a detector, and measuring the beat frequency by comparison with a cali-

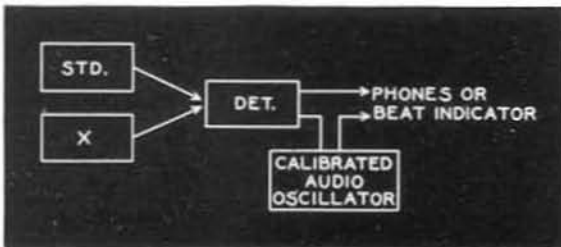

FIGURE 5. Functional diagram showing the operation of the direct-beating method of frequency measurement.

brated audio oscillator as indicated in Figure 5.

The TYPE 1105-A Frequency Measuring Equipment has been designed as an assembly of the necessary instruments for measuring unknown frequencies in terms of standard-frequency harmonics obtained from the TYPE 1100 Frequency Standard. This assembly includes an interpolation oscillator and comparison oscilloscope for measuring audio and beat frequencies, as well as the necessary radio-frequency detectors and calibrated oscillators used in measuring the higher frequencies. Complete descriptions of this equipment are given on pages 167 to 175.

WIDE-RANGE FREQUENCY METERS

For many applications it is not necessary to have the accuracy provided by a frequency standard, nor is it always possible to use conveniently such a relatively large piece of apparatus. Accordingly several different types of frequency-measuring instruments have been developed to supplement the standard over various frequency and accuracy ranges. The simplest of these is the time-honored resonant-circuit wavemeter, which is still a valuable tool for general experimental work or for making preliminary adjustments on oscillators and transmitters. Several models of wavemeters covering different frequency ranges, accuracies, and resonance indicators are described in detail on pages 193 to 196.

The heterodyne frequency meter is capable of making measurements more accurately than the wavemeter and still is small enough so that portability and simplicity are not lost. One model, the TYPE 620-A, described on page 178, contains a one-megacycle crystal calibrator which makes possible frequency measurements to an accuracy of 0.01%. The TYPE 720-A is a 0.1% instrument for use up to 3000 megacycles. The direct-reading dials on these instruments make rapid measurements possible.

The TYPE 1110-A Interpolating Frequency Standard, page 176, is a new type of instrument designed particularly for use with heterodyne frequency meters to extend accurate frequency measurements up to 2000 or 3000 megacycles. This instrument is essentially a crystal-controlled frequency standard variable over the range from 1000 to 1010 kilocycles. Two multivibrator units give 100-ke and 1-Mc harmonics. The fact that the oscillator and multivibrator outputs are variable over a 1% range means that this instrument can be used with a heterodyne frequency meter such as the TYPE 720-A, page 180, to provide an accurate check point at



any point on the dial of the TYPE 720-A. Thus the accuracy of high-frequency measurements made with the TYPE 720-A Heterodyne Frequency Meter is improved to at least 25 parts per million.

FREQUENCY MONITORS

As contrasted with the problem of frequency measurements over wide ranges of frequencies, certain operating requirements demand the continuous measurement of a single, or a very few frequencies. The continuous monitoring of the frequency of a radio transmitter is one instance. Frequency monitors are now required by law for many classes of service in the United States and foreign countries.

For continuous monitoring, the process of measurement must be reduced either to automatic or very simple operation. In the TYPE 1181-A Frequency Deviation Monitor, designed for the standard broadcast frequency range (see page 182), the carrier frequency is compared with that of a piezo-electric oscillator which is offset from the assigned carrier frequency by 1000 cycles. The carrier and secondary standard frequencies are fed to a detector, where the beat-frequency difference is obtained and is then amplified. The amplified output is then passed to a frequency-indicating device, usually referred to as a frequency-deviation meter. If the transmitter frequency varies with reference to the frequency of the secondary standard, the beat-frequency also varies, and the departure from the normal value is a measure of the carrier-frequency deviation in both magnitude and sign. The carrier-frequency deviation can thus be continuously indicated on a meter; the operating personnel can easily check the frequency at any time and make the necessary adjustments to correct any deviations which occur. If desired, such deviations may be recorded, so that a permanent record of the station performance is obtained.

In some cases, especially for high-frequency services, a somewhat simpler type of monitor is more desirable. The TYPE 1175-B Frequency Monitor, for instance, has a small crystal oven which has mounting facilities for four crystals, see page 186. By using a particular harmonic of the crystal oscillator frequency it is possible to use this monitor for transmitter frequencies from 1600 kilocycles to 162 megacycles. If the transmitter is off frequency, a beat signal, whose frequency equals the transmitter deviation frequency, appears at the output terminals of the monitor and can be measured directly by means of the TYPE 1176-A Fre-

quency Meter, page 188, which has a range extending from 25 to 60,000 cycles. Provision is also made for using head telephones if the beat is in the audio range, and in all cases the direction of the deviation can be determined quickly.

A special model, the TYPE 1175-BT, page 186, has been designed to monitor the carrier frequency of television stations operating at frequencies up to 220 megacycles.

For monitoring f-m transmitters, a somewhat more complex system is required, since not only the mean frequency, but also the percentage modulation, or frequency swing, must be measured. The TYPE 1170-A F-M Monitor, described on page 184, is designed for this service. To obtain maximum stability, this monitor uses a low (150 kc) intermediate frequency, produced by beating the transmitter with a harmonic of the standard-frequency crystal oscillator. This beat is passed through an i-f amplifier and limiter, which shapes the signal into square-topped pulses of steep wavefront. These squared pulses are then applied to a counter-type discriminator, the output of which has a d-c component corresponding to the mean frequency and an a-c component corresponding to the original modulating frequency. The d-c component operates a meter to indicate center frequency, and the a-c component operates a conventional modulation monitor circuit and provides a high fidelity signal for distortion measurements. A 600-ohm output for audible monitoring is also provided.

LOW-FREQUENCY STANDARDS

Where only a single standard frequency below 100 cycles per second is desired, neither the complexity or the accuracy of the primary standard is usually needed. For these applications the tuning fork standards listed in this section are satisfactory. TYPE 815 Precision Forks are low-power, battery-driven devices with stabilities of the order of 0.01%. The vacuum-tube driven models, TYPE 816, are temperature-controlled and are stable to 0.001%.

AUDIO FREQUENCIES

For the direct measurement of audio frequencies, two instruments are available, the TYPE 1176-A Frequency Meter, a direct-indicating device for measuring frequencies up to 60 kc, and the TYPE 1141-A Audio-Frequency Meter, a null-type Wien Bridge with a direct-reading dial from 20 cycles to 20 kc.



TYPE 1100-A FREQUENCY STANDARDS

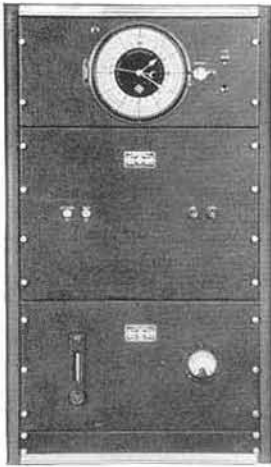

(Above) View of the TYPE 1100-AP Primary Standard of Frequency. The individual panels are mounted in a bench-type cabinet rack. When the standard is supplied with the TYPE 1105-A Frequency Measuring Equipment, a floor-type rack is furnished, and the TYPE 1107-A Interpolation Oscillator is also mounted in this rack.

The TYPE 1100-A Frequency Standards are completely new and highly precise standards of frequency, operating on the principles outlined on pages 160 and 161. Two models are available, the TYPE 1100-AP Primary Standard and the TYPE 1100-AQ Secondary Standard. The same basic elements are used in each, and there is no difference in accuracy and stability between the two assemblies.

The primary standard is provided with a Synchronometer (synchronous motor clock) for evaluating its frequency directly in terms of standard time. The secondary standard has no synchronometer. All other specifications are identical with those for the primary standard.

Harmonic series based on fundamentals of 0.1, 1, 10, and 100 kilocycles are available at its output terminals to furnish usable standard frequencies over a wide range. The accuracy of all output frequencies is the same and is better than five parts in ten million over periods of several months.

Unless otherwise specified, each assembly is supplied in a bench-type relay rack. When the TYPE 1105-A Frequency Measuring Equipment is ordered with either standard, floor-type racks are supplied.

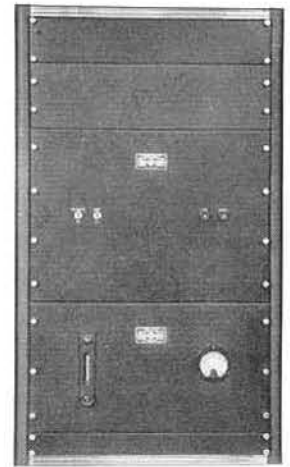

(Above) View of the TYPE 1100-AQ Secondary Frequency Standard. The cabinet rack is designed to be used on a table or bench. No synchronometer is included with this assembly, and a blank panel is supplied to fill the unused space at the top of the rack.

(Below) Functional block diagram of the frequencies obtainable from a TYPE 1100-A Frequency Standard.

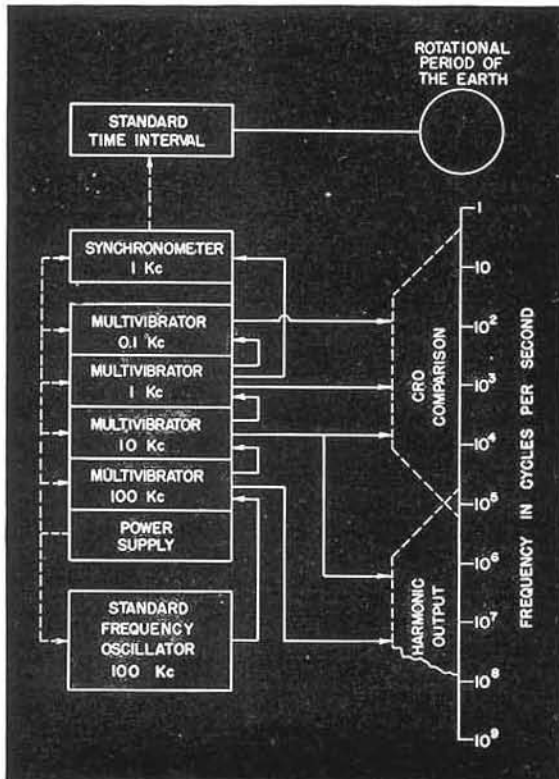

A functional layout of the standard is shown below. Brief descriptions of the individual units are given on the following page, and complete specifications on page 166.

A newly designed assembly of frequency measuring equipment for use with these standards is described on pages 167 to 169.

General Radio Frequency Standards are known the world over for reliability and accuracy. They are used by governmental agencies, industrial plants, military services, and research laboratories. These new models have all the features of their famous predecessors, plus many additional advantages in convenience, size, weight, performance and appearance, that result from General Radio's continuous program of research and development in the field of frequency measurement and standardization.

The primary standard is an excellent national standard of frequency for communications ministries, and with the TYPE 1105-A Frequency Measuring Equipment, can be used to monitor or to measure the frequencies of radio stations. It is also suitable for use as a standard clock by observatories. Research laboratories and radio manufacturing plants should use the primary standard whenever the requirements make it advisable to have an independent check against time.

For many uses the timing feature of the primary standard is not needed, and the secondary standard, which offers the same stability at a lower price, can be used. With the secondary standard, an accurate check upon its frequency can be made by a comparison with standard-frequency radio transmissions such as those of the National Bureau of Standards at Washington. This comparison

is adequate to evaluate the frequency of the standard to a few parts in one hundred million.

Shown below are the individual panels that make up the standard, with brief descriptions of their characteristics. Additional details of circuit and construction will gladly be supplied upon request. Specifications and prices are listed on page 166.

TYPE 1103-A SYNCHRONOMETER

This panel includes a 1000-cycle synchronous motor for effectively counting the number of cycles executed by the standard piezo-electric oscillator in a standard time interval. A large, illuminated, 24-hour dial with a long sweep hand makes for easy visibility. A microdial contactor, operating once each second, and calibrated in hundredths of a second, is provided for comparison with time signals. The microdial mechanism can be phased by means of a panel control. Comparison of the synchronometer reading with standard time can be made on the microdial scale to one part in ten million over a 24-hour interval. The 1000-cycle synchronous motor is started by a 60-cycle motor controlled by a push-button on the panel.

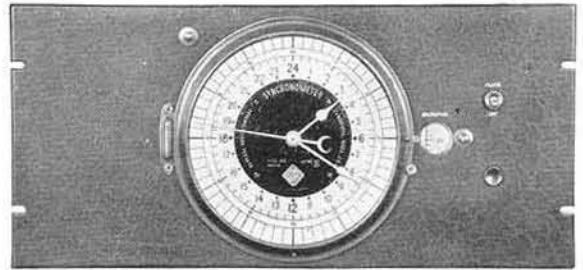

TYPE 1102-A MULTIVIBRATOR AND POWER SUPPLY UNIT

This unit contains four multivibrators of 100, 10, 1, and 0.1 ke frequencies, the power supply for the entire standard, and the control circuits of the temperature-control system of the TYPE 1101-A Piezo-Electric Oscillator. Concentric shielded connectors are provided for 100-ke and 10-ke harmonic outputs, for radio frequency measurements, and 10 ke, 1 ke and 0.1 ke for audio frequency measurements. These connections are all mounted on the rear of the assembly. All tubes are accessible from the rear, without removal of any dust covers. The four multivibrators are mounted on the rear panel, which is removable without disconnecting any wiring. Mounting spacers and servicing cable are supplied to operate the multivibrators when the panel is reversed, giving access to all components of the multivibrator assembly.

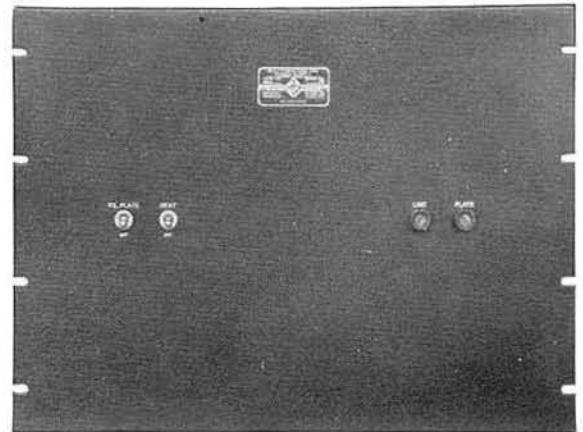

TYPE 1101-A PIEZO-ELECTRIC OSCILLATOR

This oscillator operates with a TYPE 1190-A Quartz Bar, which is mounted in the temperature-control unit, located at the left behind the panel. The temperature is controlled by a compensated thermostat circuit and is maintained within 0.01° C for all ordinary ambient temperatures. The oscillator circuit assembly is mounted at the right behind the panel. All tubes are accessible from the rear without removing any dust covers. The oscillator panel is removable on disconnecting leads to the quartz bar and removing the connecting cable plug. A bridge-type oscillator circuit is used.

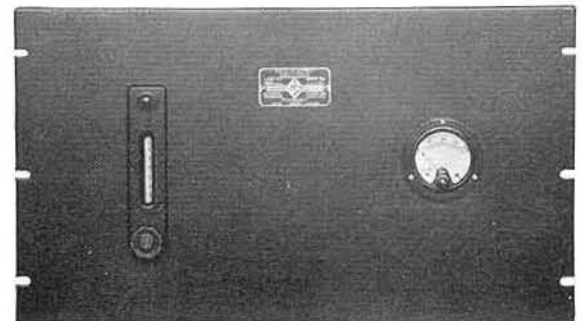

A view of the TYPE 1190-A Quartz Bar is shown on page 161.

TYPE 480-BA CABINET RACK

(not shown above)

A bench-type cabinet rack is supplied to house the complete frequency standard. When the TYPE 1105-A

Frequency Measuring Equipment is ordered with the standard, a floor-type rack is supplied. Openings, with removable finished covers, are provided for connections between the standard and the measuring equipment.

FREQUENCY

SPECIFICATIONS

Frequency Range: Standard frequencies ranging from one pulse per second to frequencies of several megacycles can be obtained from this equipment.

The output frequencies are as follows. The upper frequency limit depends upon the method used to detect and utilize the harmonics. The values here quoted are easily reached when using the TYPE 1106 Frequency Transfer Units.

From 100-ke multivibrator, 100 ke and its harmonics up to 50 megacycles.

From 10-ke multivibrator, 10 ke and its harmonics up to 10 megacycles.

From 1-ke multivibrator, 1 ke and its harmonics in the audio-frequency range.

From 100-cycle multivibrator, 100 cycles and its harmonics in the lower audio range.

From the synchrometer unit, one-second contactor. The time of occurrence of the contact may be phased to occur at any instant over a range of one second.

If a suitable high-frequency receiver is used to detect them, 100-ke harmonics up to 75 or more megacycles can be utilized directly. For work at higher frequencies, harmonics of an auxiliary oscillator whose fundamental is monitored against the standard at a lower frequency can be used.

Output Voltage: The harmonic outputs of the 100 and 10 ke are at low impedance (65 ohms). The r-m-s voltages, measured at the terminals of the frequency standard, across a 65-ohm load, are: at 100 ke, 0.2 volt; and 10 ke, 1.2 volts. The audio-frequency outputs are at low impedance (600 ohms). The r-m-s voltages measured at the terminal strip of the standard, across a 10,000-ohm load, are: 10 ke, 20 volts; 1 ke, 25 volts; 100 cycles, 20 volts. These voltages are representative only; they are not guaranteed values.

Frequency Adjustment: The frequency of the quartz bar in its oscillator circuit is adjusted to within 1 part in ten million of its specified frequency in terms of standard time. Slight changes in frequency may occur during shipment but a control is provided for adjusting the frequency after installation.

Accuracy: When the assembly is operated in accordance with instructions, and after an ageing period of a month, the rate of drift of the frequency will remain below 5 parts in 10^8 per day and this will decrease with time to about 0.5 part in 10^8 per day at the end of one year's operation.

Frequency Stability: The standard is designed so that ordinary changes in air pressure, ambient temperature, and line voltage have practically no effect on the fre-

quency. The temperature coefficient of frequency of the quartz bar is less than 1 part in 10^7 per degree C. The temperature control is within $\pm 0.01^\circ$ C. The voltage coefficient of frequency of the crystal-controlled oscillator is approximately 2 parts in 10^8 for line voltage changes of 10%. The average frequency variation from this cause will be substantially less.

The fluctuations of frequency of the standard over short periods, such as those required in making frequency measurements are less than 1 part in 10^9 .

Output Terminals: The various output frequencies are made available at shielded plug connections at the rear of the assembly. Since all necessary wiring, for all interconnections between units of the assembly, is provided in the form of cables, no connections need be made by the user other than power-supply connections, and a connection to the point where the standard frequencies are to be used.

Vacuum Tubes: The following tubes are required and are supplied with the assembly:

| | |
|------------|------------------|
| 1—6AC7 | 1—6H6 |
| 10—6SN7-GT | 1—6K6-GT/G |
| 1—5R4-GY | 1—TYPE 2 LAP-430 |

Power Supply: 105 to 125 (or 210 to 250) volts, 50 to 60 cycles.

Power Input: For the TYPE 1100-AQ Secondary Standard, the power demand from the supply line is approximately 155 watts; with heaters off, the power required is approximately 125 watts. For the TYPE 1100-AP Primary Standard, the corresponding figures are 175 and 145 watts, respectively.

Accessories Supplied: Complete set of tubes, spare sets of fuses, fusible links, pilot lights. All connecting cables, including power-supply leads, servicing cable, and complete operating instructions.

Mounting: All units are mounted on standard 19-inch relay-rack panels finished in black crackle lacquer, dress panel construction. A cabinet rack, black wrinkle finish, is supplied for mounting the units of the assembly.

Dimensions: The over-all dimensions of the assembly in bench-type cabinet rack are (height) 43 x (width) 22 x (depth) 15 $\frac{1}{4}$ inches. The available panel space is 19 rack units or 33 $\frac{1}{4}$ inches.

Net Weight: In bench-type racks, TYPE 1100-AP, 200 pounds, TYPE 1100-AQ, 165 pounds; in floor-type racks, TYPE 1100-AP, 335 pounds, TYPE 1100-AQ, 300 pounds.

| Type | Code Word | Price |
|---------|-----------|-----------|
| 1100-AP | EXCEL | \$2235.00 |
| 1100-AQ | EXACT | 1590.00 |

PATENT NOTICE. See Notes 1, 8, 12, 19, 27, 29, page vi.

When ordering either standard for use with TYPE 1105-A Frequency Measuring Equipment, be sure to specify TYPE 480-PA (floor-type) relay rack. Otherwise a TYPE 480-BA (bench-type) rack will be furnished.



TYPE 1105-A FREQUENCY MEASURING EQUIPMENT

The TYPE 1105-A Frequency Measuring Equipment includes all the auxiliary equipment necessary for measuring unknown frequencies in terms of the TYPE 1100-A Frequency Standards. The general arrangement of equipment and the method of measurement is shown in the functional block diagram, page 169. When this assembly is used in conjunction with either model of the TYPE 1100-A Frequency Standard, measurements can be made directly at frequencies up to 100 Mc. Measurements at higher frequencies can be made by using auxiliary equipment, such as receivers or oscillators, to transfer the unknown in harmonic steps to a frequency below 100 Mc. Where the frequency range to be used is smaller or the type of measurement to be made is specialized, simpler assemblies can be furnished, and quotations will be made upon request.

The individual instruments comprising the TYPE 1105-A Frequency Measuring Assembly are available separately, and all are described in detail in the following pages.

The general method of measurement is outlined in the diagram on page 169. At radio frequencies between about 100 kc and 100 Mc, the unknown frequency is brought into the measuring system through the detector section of a frequency transfer unit or through an external radio receiver. The direct-reading scale of the frequency transfer unit gives the approximate value of the unknown frequency. For a precise determination, the beat frequency between the unknown and a standard frequency harmonic is measured by comparison with the interpolation oscillator, the comparison being made on the oscilloscope.

Above 100 Mc, external frequency meters such as the TYPE 720-A and TYPE 620-A can be used to establish a harmonic relation between the unknown and the standard frequency. Other types of stable oscillators can also be used for this purpose.

At audio frequencies, the interpolation oscillator is matched directly to the unknown frequency. A harmonic of the unknown can be used at low audio and sub-audible frequencies.

Between about 5 kc and 100 kc, the interpolation oscillator is used to produce a variable frequency circular sweep on the oscilloscope. The unknown frequency is then determined from the oscilloscope pattern.

The accuracy of measurement that can be easily realized is ± 0.1 cycle in determining the difference between unknown and standard

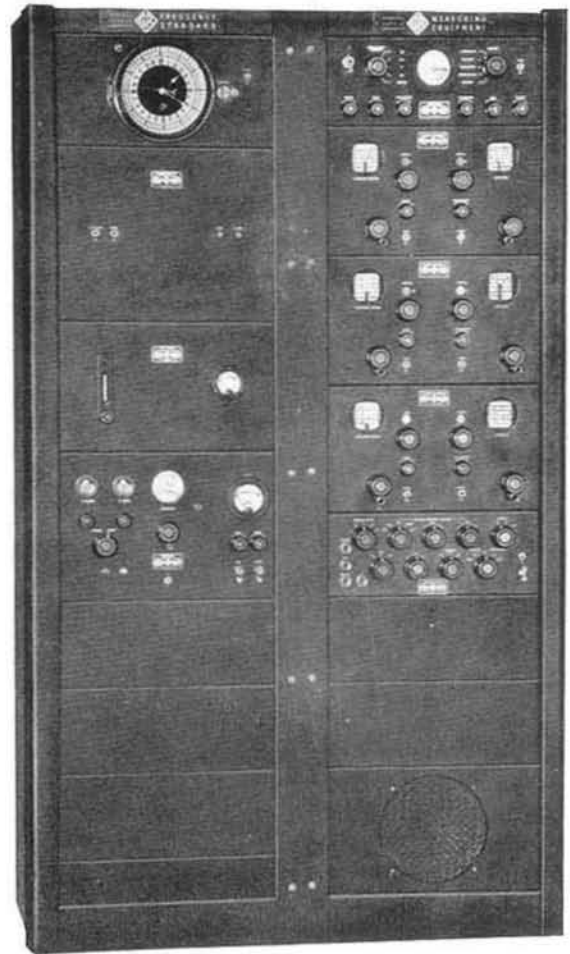

View of TYPE 1105-A Frequency Measuring Equipment with TYPE 1100-AP Primary Frequency Standard. The measuring equipment assembly is supplied with one floor-type relay rack, and the TYPE 1107-A Interpolation Oscillator mounts in the frequency standard rack, below the standard.

frequencies. The fractional accuracy varies with the frequency being measured ranging from 2 in 10^5 at low frequencies to 1 in 10^8 at high frequencies.

By reversing the procedure of measurement, a precisely known frequency of any value between 100 kc and 200 Mc can be generated. The desired frequency is available at the output terminals of a frequency transfer unit. At audio frequencies, from the interpolation oscillator, audio frequencies between 0 and 5000 cycles are available.

This equipment is the result of some twenty years of continuous development, and, simplicity of operation has, next to accuracy, been the guiding principle in its design.

FREQUENCY

TYPE 1105-A FREQUENCY MEASURING EQUIPMENT



TYPE 1109-A COMPARISON OSCILLOSCOPE

This unit contains a cathode ray oscilloscope, with its power supply; selecting, smoothing and phase-shifting networks for circular sweeps at line frequency, 0.1, 1, and 10 kc standard frequencies, and at a variable frequency obtained from the interpolation oscillator; and a selector providing for all necessary and convenient comparisons required in making frequency measurements. Most patterns are presented on a circular sweep by radial deflection.

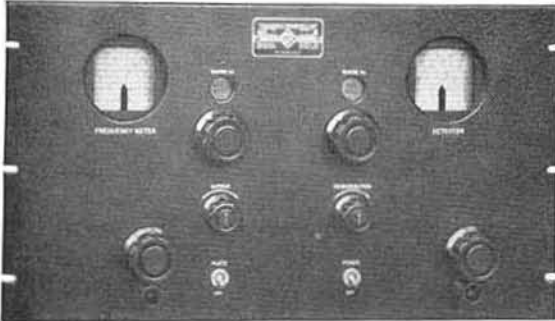

TYPE 1106-A, -B, -C FREQUENCY TRANSFER UNITS

(3 Panels)

Each of these units contain a heterodyne frequency meter and heterodyne detector, with direct-reading scales. Ranges are as follows:

| | |
|-------------|-------------------|
| TYPE 1106-A | 100 kc to 2000 kc |
| TYPE 1106-B | 1 Mc to 10 Mc |
| TYPE 1106-C | 10 Mc to 100 Mc |

The harmonic output of the frequency meter can be used at frequencies higher than those covered by the dial ranges, as explained in the operating instructions. The output of the frequency meter is adjustable by a panel control, as is the regeneration of the heterodyne detector.

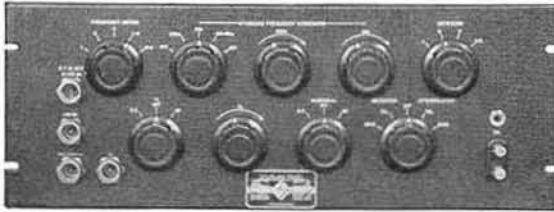

TYPE 1108-A COUPLING PANEL

This unit is the centralized control point at which all switching and level adjustments necessary for using the various combinations of measuring equipment can be easily and quickly carried out.

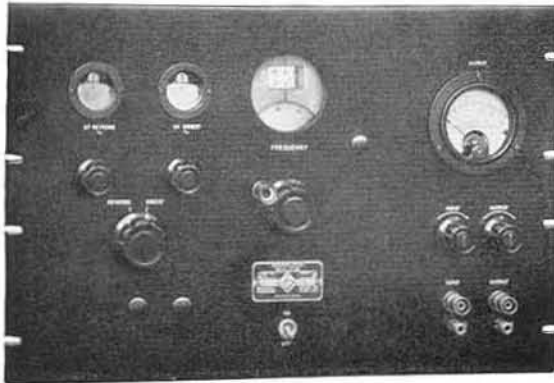

TYPE 1107-A INTERPOLATION OSCILLATOR

This unit is a direct-reading audio-frequency oscillator covering frequencies from 0 to 5000 cycles. It is used to measure the audio-frequency difference between the unknown frequency and a standard 10-kc harmonic. Provision is made, on two scales, so that results can be obtained by addition only, avoiding subtraction. A mixer circuit is provided with controls for output of the interpolator and for the unknown frequency, so that a maximum beat amplitude can be obtained. A meter indicates output voltage and can be used as a beat indicator for matching the interpolator and unknown frequencies.

TYPE 480-MA RELAY RACK

The individual units, with the exception of the TYPE 1107-A Interpolation Oscillator, are mounted in the TYPE 480-MA Relay Rack. At the base of the rack

is mounted a TYPE 1105-P1 Speaker for audible monitoring of beat tones.

All connections between standard and measuring assembly are made by means of patch cords, which are supplied.

Each of the instruments comprising the TYPE 1105-A Frequency Measuring Equipment is available separately. All are completely described in the following pages, and those descriptions should be consulted for further details of design and construction, net weight, dimensions, etc.

SPECIFICATIONS

Terminals and Connections: All instruments are equipped with shielded concentric connectors on the rear of each unit. Suitable connecting cords are supplied.

Power Supply: 105 to 125 (or 210 to 250) volts, 50-60 cycles. Other voltages or frequencies on special order only.

Power Input: 200 watts.

Accessories Supplied: Complete set of tubes, spare sets of fuses, pilot lights. Connecting cables, including power supply cords. Complete operating instructions.

Mounting: The complete assembly, with the exception of TYPE 1107-A Interpolation Oscillator, mounts in a standard 19-inch TYPE 480-MA Cabinet Rack. This rack includes service outlets for each instrument. *The interpolation oscillator mounts in the frequency standard rack, as shown in the photograph on page 167.*

Dimensions: (Height) $76\frac{1}{8}$ x (width) 22 x (depth) $20\frac{1}{2}$ inches, over-all. Total rack space is 40 rack units, or 70 inches.

Net Weight: 370 lbs., including rack.

| Type | Code Word | Price |
|--|-----------|------------------|
| 1105-A Frequency Measuring Equipment | MITER | Price on Request |

This diagram shows in functional form the operation of the TYPE 1105 Frequency Measuring Assembly. The TYPE 1108 Coupling Panel is the central unit from which all operations are controlled.

The unknown frequency f_x and a series of standard frequency harmonics are applied through attenuators to

the heterodyne detector. The unknown can then be estimated quickly from the calibration of the detector, or be determined more accurately by use of the heterodyne frequency meter, or be measured precisely by use of the interpolation oscillator.

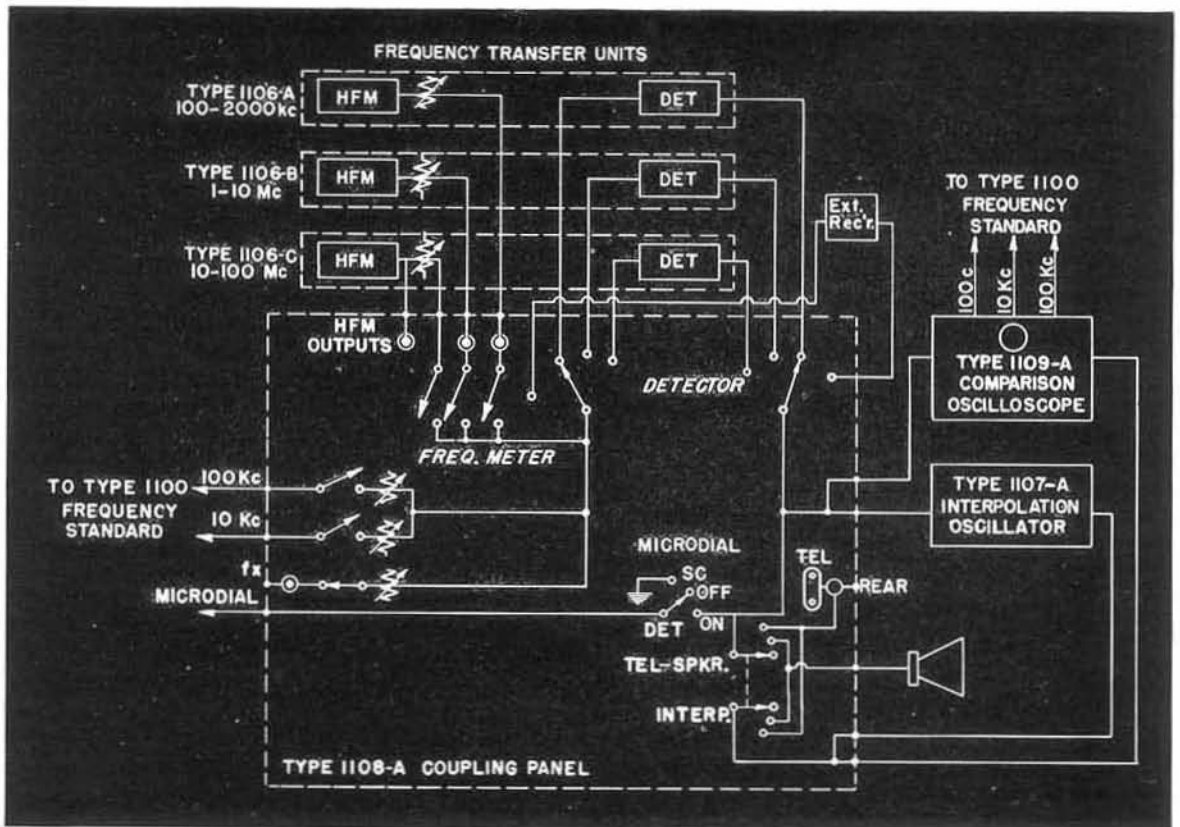

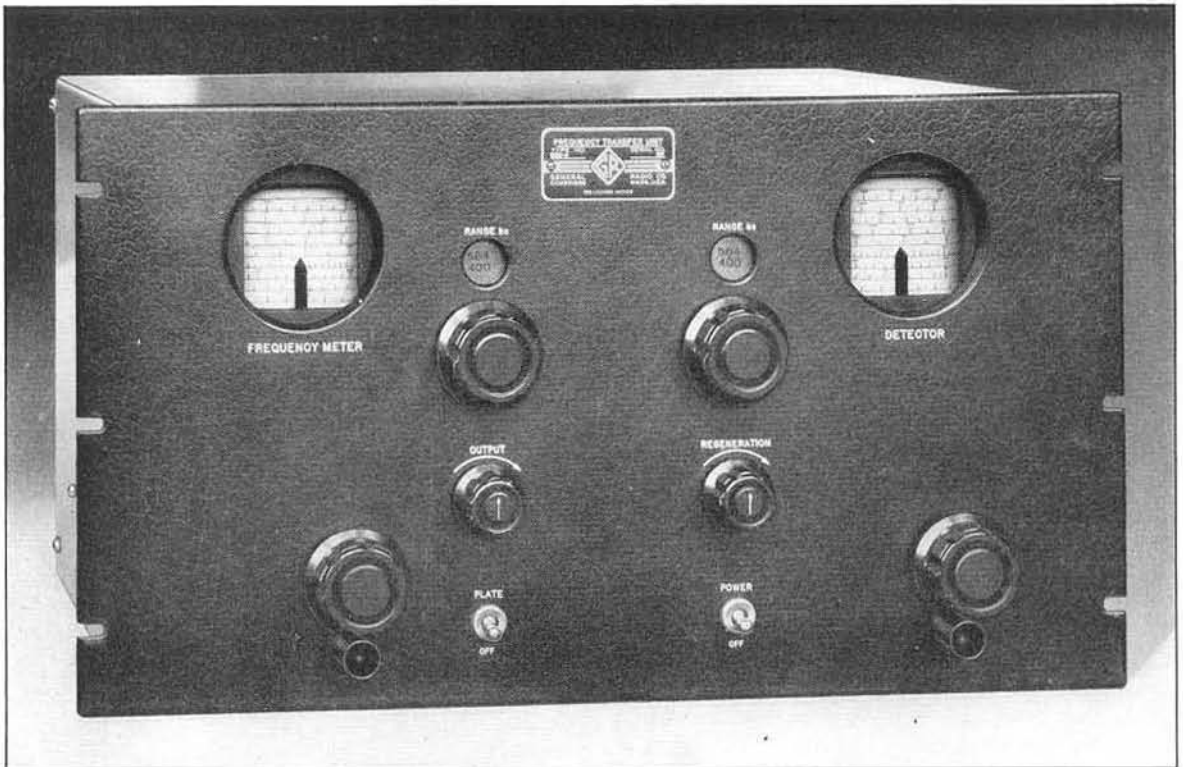

TYPE 1106 FREQUENCY TRANSFER UNITS

USES: The TYPE 1106 Frequency Transfer Units are utilized in transferring an unknown frequency for measurement against a frequency standard, or for transferring a frequency of known value (determined against the standard) to an output circuit. The direct-reading frequency calibrations will give the approximate value of an unknown frequency, or the approximate value of a desired frequency in the output circuit.

When used with a frequency standard, these units provide means for rapidly identifying the harmonics of the standard; for accurately matching the heterodyne frequency meter to the unknown frequency; for use as a substitute source in measuring frequencies under conditions of noise, fading or of intermittent operation of the transmitter; and for obtaining a frequency of any desired value, accurately known in terms of the frequency standard. These instruments can also be used as general purpose calibrated frequency meters and detectors.

DESCRIPTION: The TYPES 1106-A, 1106-B and 1106-C Frequency Transfer Units are identical except for their frequency ranges which are:

| | |
|-------------|-------------------|
| TYPE 1106-A | 100 kc to 2000 kc |
| TYPE 1106-B | 1 Mc to 10 Mc |
| TYPE 1106-C | 10 Mc to 100 Mc |

Each consists of a heterodyne frequency meter (with harmonic generating circuits and output control) and a heterodyne detector (with audio-frequency amplifier and regeneration control).

The heterodyne frequency meter oscillator circuit is a highly stable oscillator having a frequency range of 2 to 1 in two (1106-A) or three steps (1106-B, -C). A direct-reading frequency scale is provided for the fundamental and selected harmonic ranges, covering 10 to 1 in frequency (20 to 1 on 1106-A). The harmonic output can be used at frequencies higher than those covered on the dial ranges; for example, using the fundamental frequency scales and reading ten times the scale value gives the coverage of the tenth harmonic. Full details of operation are given in the instructions.

The heterodyne detector has range-switching and direct-reading frequency scales covering the rated range of the unit. The detector can be operated either in the non-oscillating or oscillating condition by use of the regeneration control. When oscillating, it is especially useful in obtaining an exact zero beat setting between the frequency meter and a signal frequency, by the three-oscillator method, the detector serving as the third oscillator. When not oscillating, it produces the beat between the standard harmonic and the

unknown frequency. An audio-frequency amplifier with an output impedance of approximately 600 ohms is provided.

On both the heterodyne frequency meter and detector direct-reading frequency scales, nearly 360 degree rotation of the drum dials is used. Both are approximately straight-line-frequency in calibration. Operation of the range selectors automatically sets the pointers so that the likelihood of error in reading one of the several scales on the dial is greatly reduced.

FEATURES: ▶ Dials are direct-reading in frequency for both the frequency meter and the detector.

▶ Range dials are illuminated and are mounted behind panel and viewed through a window.

▶ Range switching for both frequency meter and detector.

▶ The heterodyne frequency meter is designed for a high degree of frequency stability, and drift is negligible for the specified conditions of use.

SPECIFICATIONS

Frequency Range:

| | | |
|-------------|-------------------|-------------|
| TYPE 1106-A | 100 kc to 2000 kc | (9 ranges) |
| TYPE 1106-B | 1 Mc to 10 Mc | (10 ranges) |
| TYPE 1106-C | 10 Mc to 100 Mc | (10 ranges) |

The heterodyne frequency meters all have 2:1 fundamental ranges, with calibrated direct-reading harmonic scales. The heterodyne detectors all have fundamental ranges covering the specified band.

Calibration: The heterodyne frequency meter dials are calibrated as follows:

| | | |
|-------------|------------------|------------------|
| TYPE 1106-A | 1 ke intervals | 100 to 400 kc |
| | 5 ke intervals | 400 to 2000 kc |
| TYPE 1106-B | 5 ke intervals | 1.00 to 2.00 Mc |
| | 10 ke intervals | 2.00 to 10.00 Mc |
| TYPE 1106-C | 20 ke intervals | 10.0 to 20.0 Mc |
| | 100 ke intervals | 20.0 to 100.0 Mc |

The heterodyne detector dials are calibrated with somewhat greater frequency intervals, but the intervals permit reasonable estimation of frequency.

Accuracy: The accuracy of the heterodyne frequency meter calibration permits positive identification of harmonics, when used with a frequency standard. Used individually, the calibration can be relied upon to ±0.1 per cent.

Frequency Stability: The circuits of the oscillators used for the heterodyne frequency meters are designed for high stability against changes in supply voltage or changes in tube capacitances. The heterodyne detector stability is not as good, but is sufficiently high so that no difficulty is encountered from variations in making frequency measurements.

Input and Output Circuits: The harmonic output of the heterodyne frequency meters is available at shielded

concentric jacks for use with 50-65 ohm concentric cable. Harmonics of the fundamental frequency to at least the 10th are usable. The radio-frequency input and the audio-frequency output connections of the heterodyne detector are shielded concentric jacks. The input circuit is suitable for use with 50-65 ohm cable; the output impedance is approximately 600 ohms.

Power Supply: 105 to 125 (or 210 to 250) volts 50-60 cycles. Other voltages or frequencies on special order only.

Power Input: 40 watts.

Tubes: Supplied with instruments:

| | |
|-----------------|-------------|
| TYPE 1106-A, -B | TYPE 1106-C |
| 3-6SJ7 | 1-6SJ7 |
| 1-6J5 | 1-6J5 |
| 1-6SN7GT | 1-6SN7GT |
| 1-6H6 | 1-6X5G |
| 1-6X5G | 1-9001 |
| 1-0D3/VR150 | 1-0D3/VR150 |
| | 2-9002 |

Accessories Supplied: Spare pilot lights and fuses; line connector cord.

Controls: Power ON-OFF switch; heterodyne frequency meter PLATE supply switch; heterodyne frequency meter and heterodyne detector RANGE (coil selector) switches; frequency controls; heterodyne frequency meter OUTPUT control; heterodyne detector REGENERATION control.

Mounting: Standard 19-inch relay-rack mounting; dress-panel construction; black crackle lacquer.

Dimensions: Panel (length) 19 x (height) 10½ inches; behind panel (length) 17¼ x (height) 10¼ x (depth) 12 inches.

Net Weight: 47¾ pounds.

| Type | Code Word | Price |
|--------|-----------|------------------|
| 1106-A | ABOUT | Price on Request |
| 1106-B | ACTOR | |
| 1106-C | ADEPT | |

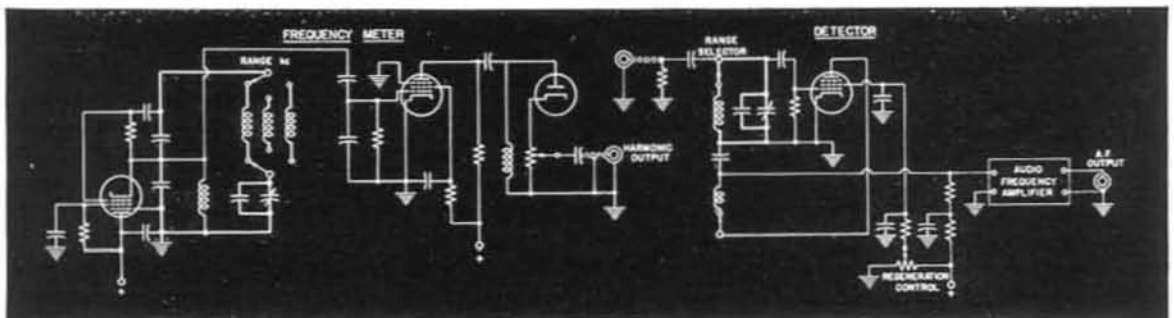

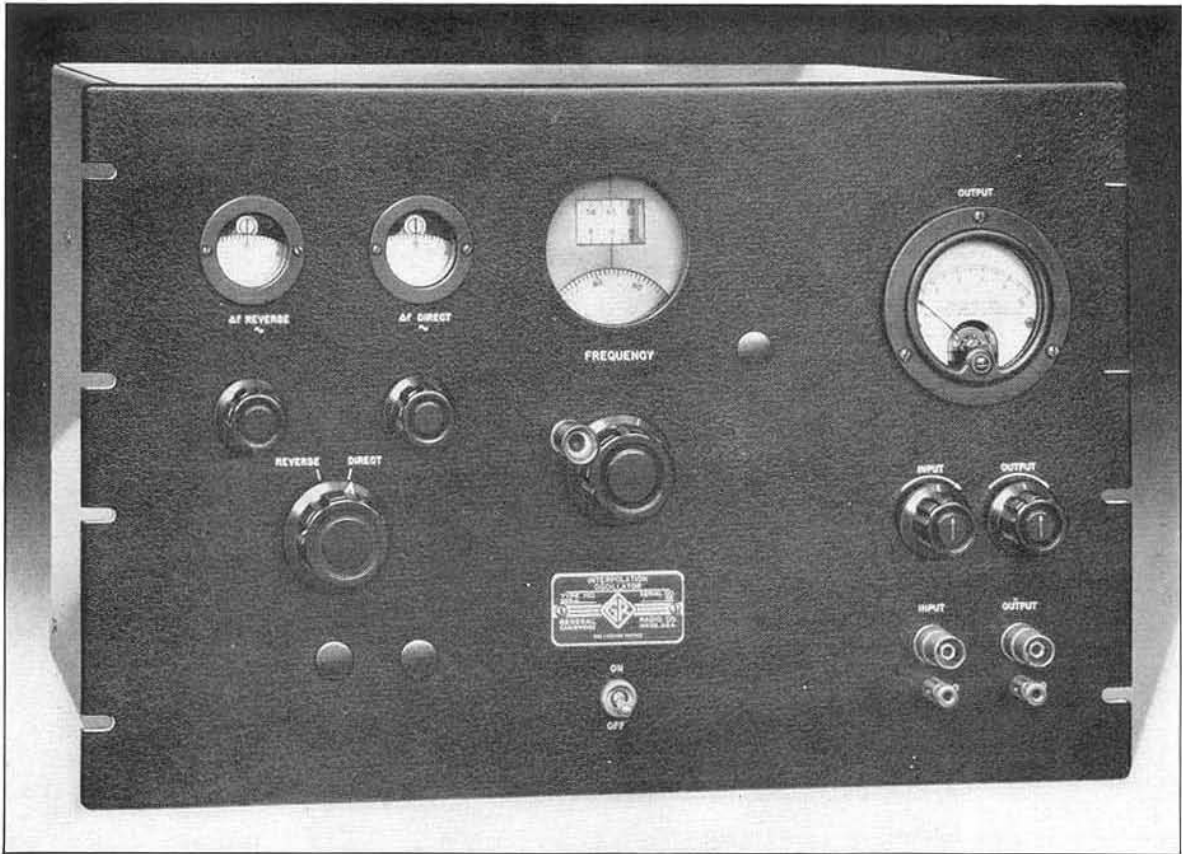

TYPE 1107-A INTERPOLATION OSCILLATOR

USES: The principal use of the TYPE 1107-A Interpolation Oscillator is, in connection with a frequency standard, to measure the difference between the unknown frequency and a known standard harmonic. The direct-reading linear scales of 0 to 5000, and 5000 to 10,000 cycles make possible the rapid evaluation of the frequency difference, by *addition* only, with high accuracy. While the dials are marked as described, the actual frequency range is 0-5000 cycles.

The linear scale of this oscillator also makes it useful for other types of work where accurate frequency increments are desired.

DESCRIPTION: The oscillator is of the beat-frequency type, with the radio-frequency oscillators operating in the region of 45-50 kc. The circuits are designed for exceptional stability of frequency against supply voltage changes, tube capacitance changes and tube replacements. A tube plate-supply regulator is then employed as a further safeguard.

The variable-frequency oscillator frequency is controlled by a precision variable air capacitor; the fixed oscillator frequency by a

fixed air capacitor. The inductors of both oscillator circuits are wound on ceramic forms and are shielded, effectively eliminating unwanted coupling and reducing the effects of changes in ambient temperature.

An output voltmeter is provided that can also be used as a beat indicator for matching the oscillator output frequency to an unknown audio frequency. Individual controls are provided for the oscillator output and unknown frequency voltages in order to secure the maximum beat amplitude at any level. The oscillator output voltage is practically constant over the whole range of frequency.

FEATURES: ► The fixed oscillator is provided with a switch which permits changing the frequency by exactly 5000 cycles. By thus changing the frequency the oscillator can be fitted with a scale reading 5000-10,000 cycles. When measuring an unknown frequency lying below the standard frequency, the beat frequency need not be subtracted from the standard frequency to obtain the unknown frequency. Instead the 5000-10,000 cycle

scale is used and the reading is *added* to the frequency of the next lower standard frequency harmonic.

- ▶ An indicator light operated by the switch indicates the proper scale to be read.
- ▶ Stability of output frequency, and linear,

easily read scales are features of great convenience in use.

- ▶ For measuring very small frequency increments, two direct-reading incremental frequency dials (one for the 0-5000 scale and one for the 5000-10,000 cycle scale) are provided.

SPECIFICATIONS

Actual Frequency Range: 0-5000 cycles per second.

Dial Calibrations: "DIRECT": 0-5000 cycles, with the oscillator frequency increasing from 0 to 5000 divisions on the scale. "REVERSE": 5000-10,000 cycles with the oscillator frequency decreasing from 5000 cycles to zero while scale reading goes from 5000-10,000 divisions.

Accuracy: The instrument is aligned to agree with the linear direct-reading scales to within ± 2 cycles.

The variable capacitor is provided with a precision worm drive so that precise frequency settings can be made. Small residual errors are easily and quickly removed in the region of any frequency in the range by fine adjustment of the zero with reference to a frequency standard having a 1-ke or 0.1-ke output, or both. For evaluating very small frequency differences, independent, direct-reading frequency increment dials are provided for the two scales.

Output: The output voltage is adjustable up to 15 volts. The output circuit impedance is approximately 600 ohms.

Mixer Circuit: A mixer circuit, with volume control, is provided for injecting a frequency to be measured into the amplifier circuit. Beats may be observed on the output meter, or by means of head telephones or speaker.

Power Supply: 105 to 125 (or 210 to 250) volts, 50-60

cycles. Other voltages or frequencies on special order only.

Power Input: 50 watts, approximately.

Controls: ON-OFF switch; DIRECT and REVERSE scale switch; Two Δf and zero-set controls; main FREQUENCY control; OUTPUT and INPUT (mixer) volume controls.

Meters: Output voltmeter; used also as a beat indicator.

Terminals: Terminals, both on panel and at rear, are provided for both mixer input and oscillator output. Panel terminals are universal for two pin or concentric plugs. Rear terminals are for concentric plugs.

Tubes: Furnished with instruments:

- 2-6SJ7
- 2-6SN7GT
- 3-6J5GT
- 1-6X5GT
- 1-0D3/VR150

Accessories Supplied: Spare pilot lights, fuses. Power cord.

Mounting: Standard 19-inch relay-rack mounting.

Dimensions: Panel (length) 19 x (height) 12 1/4 inches; behind panel, (length) 17 1/4 x (height) 12 x (depth) 12 inches.

Net Weight: 40 1/2 pounds.

| Type | | Code Word | Price |
|--------|--------------------------------|-----------|------------------|
| 1107-A | Interpolation Oscillator | BARON | Price on Request |

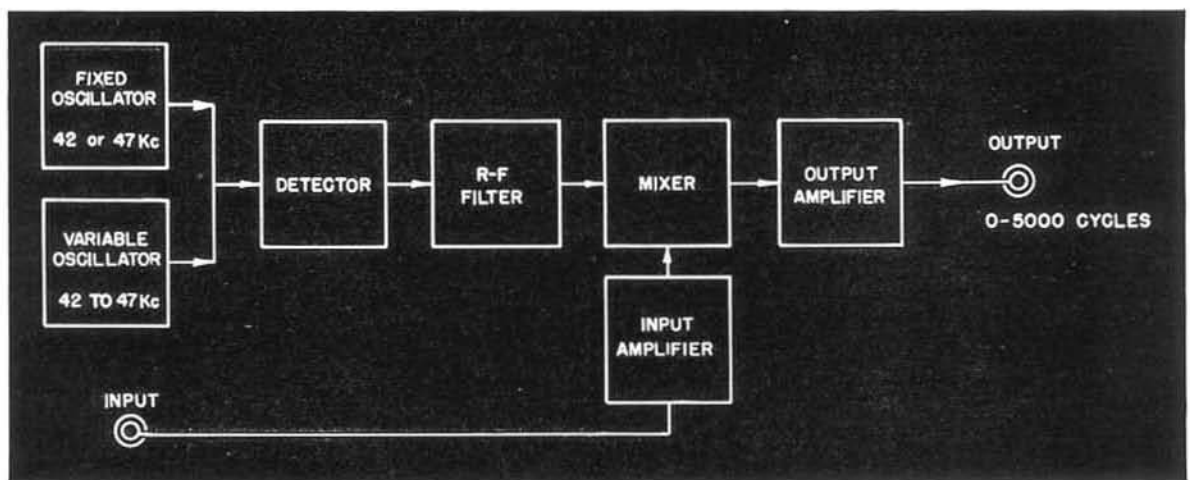



TYPE 1109-A COMPARISON OSCILLOSCOPE

USES: This instrument is particularly intended for use with a TYPE 1100-AP Primary Frequency Standard (or TYPE 1100-AQ Secondary Frequency Standard) as an aid in making interpolations or checking calibrations with high accuracy. With such standards and associated measuring equipment, the TYPE 1109-A Comparison Oscilloscope provides a convenient means of measuring audio and carrier frequencies, or of calibrating oscillators in these frequency ranges.

DESCRIPTION: The TYPE 1109-A Comparison Oscilloscope contains a 3-inch, radial deflection cathode-ray tube and its power supply. Selective amplifiers with power supply, phase-shift networks, and controls are provided for obtaining circular sweeps at frequencies of the power line, and 0.1, 1, and 10 kc from the frequency standard, and at variable frequency obtained from the TYPE 1107-A Interpolation Oscillator. A radial deflection amplifier is provided, for displaying the input signal on

the circular sweep base. Switching is provided for selecting the sweep frequencies and for selecting any one of the several operations normally involved in making frequency measurements or calibrations.

FEATURES: ▶ The general use of circular sweeps provides symmetrical and readily interpretable patterns.

▶ By overloading the deflection amplifier it is possible to identify easily frequency ratios involving much higher integers than can be identified in Lissajous patterns.

▶ Ordinarily in the use of calibrated oscillators, it is not necessary to identify a pattern, it is only necessary to adjust the oscillator so that the pattern stands still. A system of known frequencies is easily established on the basis of the *type* of pattern obtained. When used on base frequencies 10 or 100 times higher, the *same types* of pattern correspond to frequencies just 10 or 100 times higher than the original system of known frequencies.

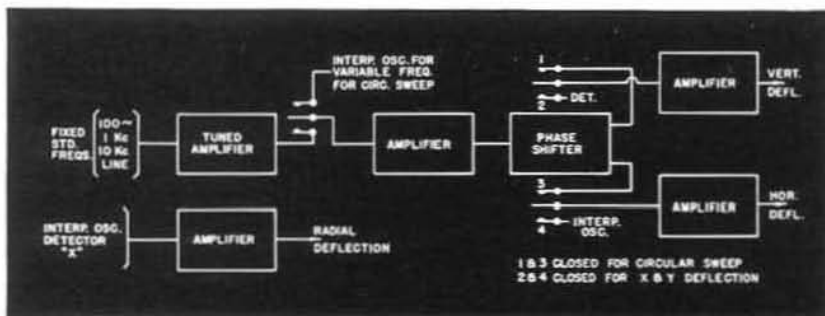

Block schematic diagram of the TYPE 1109-A Comparison Oscilloscope.

SPECIFICATIONS

Frequency Range: Useful patterns can be obtained over the frequency range from very low audio frequencies to radio frequencies of a few hundred kilocycles. In the

range up to 100 kilocycles, an input voltage of 0.5 volt gives full radial deflection. Larger voltages give very useful square-wave radial deflections.



Controls: ON-OFF switch; BRILLIANCE, FOCUS, and CENTERING adjustments for cathode-ray tube; sweep DIAMETER and SHAPING controls; FREQUENCY selector for circular sweep; SELECTOR for sources to be compared.

Terminals: At rear, by concentric plugs for standard frequencies, and for sources to be compared; on panel by universal two-point and concentric plug to source being measured or calibrated (0 to 100 kc or more).

Power Supply: 105 to 125 (or 210 to 250) volts, 50-60 cycles. Other voltages or frequencies on special order only.

Power Input: 30 watts, approximately.

Tubes Supplied: 1—Type 3DP1A, 3" radial deflection Cathode-Ray Oscilloscope

- 2—6SN7GT
- 1—6J5GT
- 1—2X2/879
- 1—6X5-GT
- 1—6SJ7

Accessories Supplied: Spare pilot lights and fuses. Line connector cord. 5 concentric plugs.

Mounting: Standard 19-inch relay-rack mounting

Dimensions: Panel (length) 19 x (height) 7 inches; behind panel, (width) 17¼ x (height) 6¾ x (depth) 12 inches.

Net Weight: 45 pounds.

| Type | Code Word | Price |
|--|-----------|------------------|
| 1109-A Comparison Oscilloscope | BASIN | Price on Request |

TYPE 1108-A COUPLING PANEL

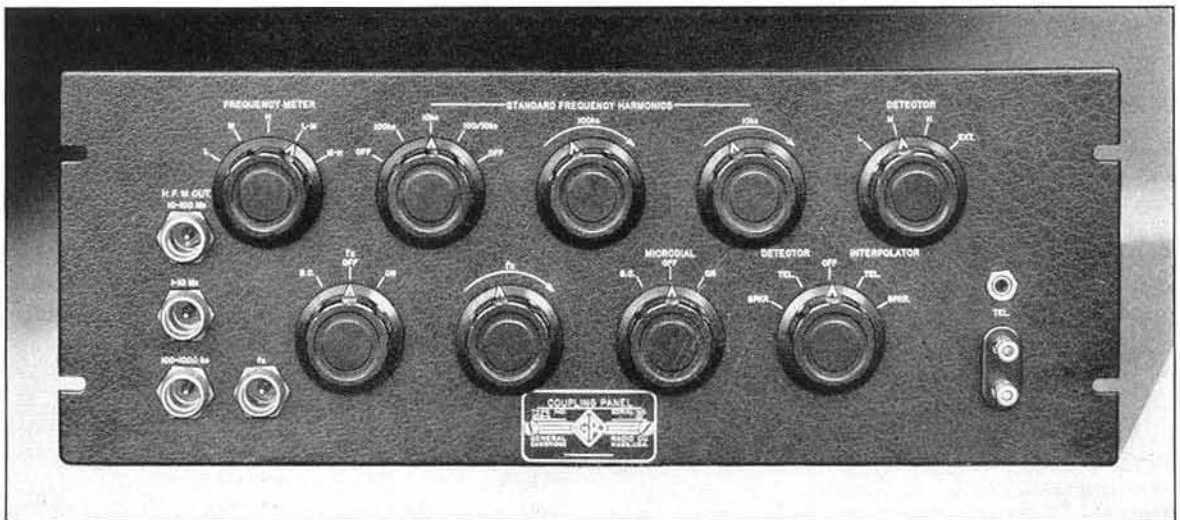

USES: This coupling panel is designed specifically for use as the centralized control panel in a frequency measuring equipment employing a TYPE 1100-AP Primary Frequency Standard (or TYPE 1100-AQ Secondary Frequency Standard). The panel carries the necessary switches and volume controls for all operations in making frequency measurements.

DESCRIPTION: The instrument contains the following controls: FREQUENCY METER, for selecting and combining the frequency

meter outputs of 1106-A, 1106-B and 1106-C heterodyne frequency meter sections; STANDARD FREQUENCY HARMONIC selector, selecting 100-ke or 10-ke harmonic outputs, or combination; individual volume controls; DETECTOR selector, for selecting input and output circuits of 1106-A, 1106-B, 1106-C or an external detector (or receiver); an ON-OFF switch and volume control for frequency being measured; MICRODIAL switch; TEL-SPEAKER switch for transferring between telephones and speaker and between detector and interpolator outputs.

SPECIFICATIONS

Terminals: At rear, by 24 shielded concentric plugs to all sources and instruments required; rear telephone connection for use when adjusting standard against standard frequency transmissions. At front, by shielded concentric plugs, harmonic output circuits of 1106-A, 1106-B, and 1106-C heterodyne frequency meter sections; input connection for frequency being measured.

By two-point or standard telephone jack, connections for telephone receivers.

Mounting: Standard 19-inch relay-rack mounting.

Dimensions: Panel (length) 19 x (height) 7 inches; behind panel (width) 17¼ x (height) 6¾ x (depth) 6½ inches.

Net Weight: 16 pounds.

| Type | Code Word | Price |
|-----------------------------------|-----------|------------------|
| 1108-A Coupling Panel | BATTY | Price on Request |



TYPE 1110-A INTERPOLATING FREQUENCY STANDARD

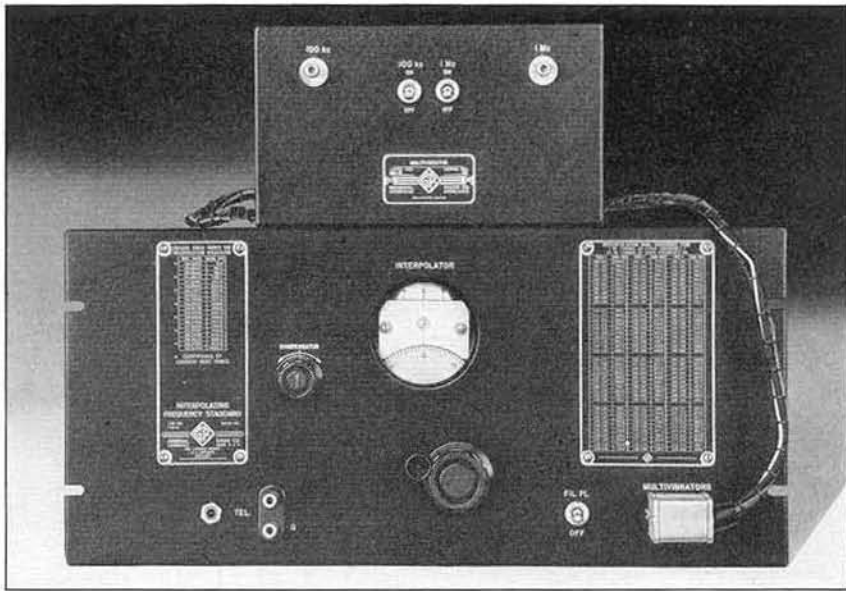

USES: This instrument is a precision interpolator for use with heterodyne frequency meters, such as the TYPE 720, in making frequency measurements in the ultra-high-frequency range, up to 2000 or 3000 Mc, and with the TYPE 620-A Heterodyne Frequency Meter in making frequency measurements from 10 Mc up to several hundred Mc. It can also be used for frequency measurements in conjunction with high-frequency receivers provided their frequency calibrations are sufficiently good to identify frequencies separated by as little as 1%.

DESCRIPTION: The block diagram indicates the essential elements of the instrument: (1) a frequency standard, variable over a range of 1000 to 1010 kc, or 1%, and (2) a multivibrator unit for frequencies of 1 Mc and 100 kc.*

The frequency standard consists of a 950 kc crystal-controlled oscillator, a highly stable 50-60 kc bridge-type variable frequency I-C oscillator, a modulator, and filter for selecting the sum of the two frequencies as the final output. The dial of the variable oscillator has 1000 divisions to cover 10 kc.

The 1% range of the output frequency means that the frequency range of any multivibrator harmonic is also 1%. The 100th harmonic of the 1-Mc multivibrator can therefore be adjusted continuously from 100 Mc to 101 Mc, giving complete coverage over this interval. At 101 Mc and higher harmonics,

the range from any multiple of 1 Mc to the next higher multiple is less than 1% and so these ranges are covered by less than full-scale variation on the variable frequency oscillator dial.

When the 100-kc multivibrator is used, the 100th harmonic again has a range of 1% as the standard frequency is changed over the full range of the dial, covering 10.0 to 10.1 Mc, and for all higher multiples the range from one multiple to the next higher is covered by less than full-scale range of the variable frequency oscillator dial.

The multivibrator harmonics give complete frequency coverage from 100 Mc upward, for the 1 Mc unit, and from 10 Mc upward, for the 100 kc unit. When the Interpolating Frequency Standard is used with the TYPE 720-B and TYPE 620-A Heterodyne Frequency Meters, having ranges of 100-200 and 10-20 Mc respectively, only the harmonics from the 100th to the 200th are used.

The dial of the TYPE 720-B, for example, covers 100-200 Mc with calibration marks at each megacycle. With the dial of the variable frequency oscillator at zero, the standard output frequency is 1 Mc exactly, and all harmonics are therefore standard frequencies, which can be used to check the heterodyne frequency meter at any scale graduation.

If the heterodyne frequency meter has been set to zero beat with a frequency to be measured, an approximate reading of the unknown frequency is given at once on the dial. As an example, suppose the reading to be 162.3 Mc. Using the Interpolating Frequency Standard,

*General Radio Experimenter, Vol. XVIII, No. 9, February 1944, "Continuous Interpolation Methods Part II—Method IV."



the 1-Mc multivibrator output is coupled to the frequency meter. The oscillator dial is then advanced from zero until the 162nd harmonic (identified by the 720-B dial reading) is advanced from 162.0 Mc to 162.3 Mc approximately where zero beat is set. The increment in frequency is determined from the variable oscillator dial and is added to 162.0 Mc to give the final result.

FEATURES: ▶ This instrument is designed for operation by zero beat adjustments only, overcoming the need for wide-band circuits or wide-band interpolating methods.

▶ All frequency increments are taken as positive, avoiding all need for subtraction or determining the sign of frequency increments.

▶ Means are provided for checking the alignment of the variable frequency oscillator calibration in terms of the 950-ke crystal frequency.

▶ Since harmonics of the multivibrators fall at all standard frequencies transmitted by the U. S. Bureau of Standards (WWV) it is possible to check the absolute accuracy, including the frequency of the 950-ke crystal, by use of a suitable receiver.

▶ To permit bringing the multivibrator output close to high-frequency equipment, the multivibrator unit is connected to the standard frequency unit by means of a cable. The small multivibrator unit can then be moved around without moving the larger unit.

SPECIFICATIONS

Frequency Range: The output frequency range of the 1110-A Interpolating Frequency Standard is from 1000 to 1010 kc. The output frequencies of the 1110-P1 Multivibrator Unit are 1.0- and 0.1-Mc fundamentals with harmonics up to 200 or more.

Calibration: The variable frequency oscillator dial has 1000 divisions corresponding to 0.001 per cent or 10 parts per million per division.

A list of check settings is provided on the panel. This check can be made at any time by simply plugging a set of headphones into the jack or binding posts provided on the panel. A trimmer control on the panel provides for adjusting the oscillator to agreement with the crystal.

To facilitate conversion of the dial readings from their basic percentage or parts per million values of frequency increment to fractions of a megacycle or of 0.1 Mc (100 kc), a table listing the number of dial divisions for frequency increments of 1.0 Mc and 0.1 Mc at each harmonic from 100 to 220 is given on the panel. A simple slide-rule ratio then gives the desired frequency increment.

Crystal Oscillator: The crystal oscillator is adjusted to within 1 part in a million of correct frequency at room temperature. It should be reliable to within ±10 parts per million at ordinary room temperatures. The crystal frequency can be checked and adjusted in terms of standard frequency transmissions from WWV using an

external receiver, maintaining the variable oscillator at exactly 50 kc in terms of the crystal.

Accuracy of Measurement: The over-all accuracy of measurement is ±25 parts per million using the oscillator dial directly. If the oscillator is carefully trimmed in terms of the crystal, the over-all accuracy is limited principally by the error of the crystal.

Vacuum Tubes: The following tubes are supplied:

- 2 — 6AC7
- 3 — 6J5GT/G
- 4 — 6SN7-GT
- 1 — 5R4GY
- 1 — 6SJ7
- 1 — 9001
- 1 — 6SA7
- 1 — 2LAP-430 (Bridge Circuit Lamp)

Power Supply: Either 105-125 or 210-250 volts, 50-60 cycles.

Power Input: 85 watts from 115-volt, 60-cycle line.

Mounting: TYPE 1110-A Relay Rack; TYPE 1110-P1 (attached to 1110-A by cable) small metal cabinet.

Accessories Supplied: Line connector cord, and TYPE 1110-P1 Multivibrator Unit with connecting cable.

Accessories Required: Head telephones.

Dimensions: 1110-A Panel (length) 19 x (height) 8 3/4; behind panel, (length) 17 1/4 x (height) 8 3/8 x (depth) 14 inches. 1110-P1 (length) 9 1/4 x (height) 5 1/4 x (depth) 5 1/4 inches.

Net Weights: Type 1110-A assembly, 40 pounds; TYPE 1110-P1 Multivibrator Unit, 7 1/2 pounds.

| Type | | Code Word | Price |
|--------|--|-----------|------------------|
| 1110-A | Interpolating Frequency Standard | RAVEN | Price on Request |

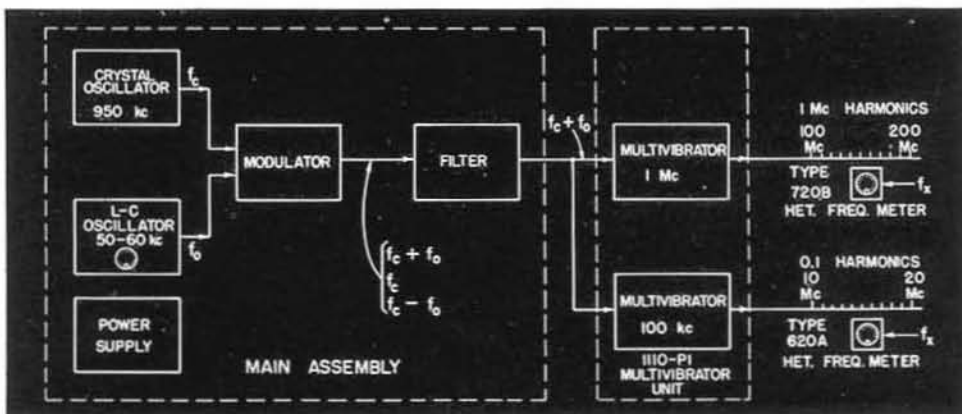



TYPE 620-A HETERODYNE FREQUENCY METER AND CALIBRATOR

USES: Although designed primarily for measuring high and ultra-high frequencies, this instrument can also be used to measure frequencies down to a few hundred kilocycles, provided the signal being measured is sufficiently strong. For communication companies it provides an excellent means of rapidly measuring the frequencies of a large number of transmitters (either local or remote) in addition to its use in calibrating and servicing receiving equipment. Receiver manufacturers will find it useful in checking the ranges of receivers and oscillators. It is suitable for monitoring the frequencies of radio transmitters where the allowable frequency tolerance is $\pm 0.02\%$ or greater.

DESCRIPTION: The schematic diagram shows the essential elements of the instrument: (1) a heterodyne frequency meter, (2) a crystal calibrator, and (3) a detector and audio amplifier.

The heterodyne frequency meter is direct reading, an important operating convenience, particularly when using harmonics. The fundamental frequency range is 10 to 20 Mc. This range is divided into 10 steps of 1 Mc each, and the desired step is selected by means of a coil switch. The main tuning capacitor covers a range of 1 Mc for each coil, the dial being engraved to read hundredths of megacycles directly. An auxiliary dial, which drives the main dial through a reduction gear train, carries a scale that subdivides the main scale divisions, the smallest

division being 0.001 Mc or 1 kc. The frequency of the heterodyne frequency meter is given by the sum of the coil switch and capacitor dial readings, subject to any scale correction as determined by the crystal calibrating points.

For checking the calibration of the heterodyne frequency meter, a piezo-electric calibrator, employing a one-megacycle low-temperature-coefficient quartz plate, is provided. Several points on each coil range of the heterodyne frequency meter may be checked.

The procedure in making measurements is simple. When the unknown frequency is within the fundamental range of the heterodyne, the heterodyne frequency is set to zero beat with the unknown, and the frequency is read directly from the dial. When the unknown is above or below the heterodyne fundamental range, the dial reading must be multiplied or divided by the harmonic number.

FEATURES: ▶ A very wide range of frequencies can be measured with the TYPE 620-A Heterodyne Frequency Meter and Calibrator.

▶ Excellent accuracy has been combined with simplicity of operation.

▶ The direct-reading frequency scale makes convenient and rapid measurements possible.

▶ A high degree of frequency stability in the oscillator is obtained by careful design and construction. Ball bearings are used in the variable air capacitor and the inductors are wound on steatite forms to keep losses and temperature coefficient low.

► Either batteries or the built-in a-c power supply can be used with any model. This feature is a great convenience when the same instrument is to be used both in the laboratory and in the field.

SPECIFICATIONS

Frequency Range: The fundamental frequency range is from 10 to 20 megacycles, in 10 ranges of 1 Mc each. By harmonic methods frequencies between 300 kc and 300 Mc are easily measured.

Frequencies up to about 300 Mc can be measured by setting a harmonic of the heterodyne frequency meter to zero beat with the unknown. In general, the beat is obtained in the detector, but for the very highest frequencies it is advisable to use an auxiliary receiver. For frequencies below 10 Mc and down to about 300 kc, harmonics of adequate strength for measurement can be generated in the detector tube provided a sufficiently strong signal is applied to the instrument. For weak signals, a local oscillator as a harmonic-generating means is necessary.

Calibration: The capacitor dials are graduated to read decimal fractions of megacycles directly, the smallest division corresponding to 0.001 Mc (1000 cycles).

Calibrator: A 1-Mc piezo-electric oscillator, employing a low-temperature-coefficient quartz plate, is provided for checking the calibration of the frequency meter. Harmonics of 1 Mc fall at the upper and lower limits of the dial, giving a bracketing check on each coil range of the heterodyne frequency meter. Harmonics of the heterodyne also produce beats with harmonics of the calibrator, giving checking points at multiples of $\frac{1}{2}$, $\frac{1}{3}$, $\frac{1}{4}$, and $\frac{1}{5}$ Mc, etc., over the dial range. Since these points occur at the same dial readings for each range, checking is made very simple and convenient.

Accuracy: The over-all accuracy of measurement is $\pm 0.01\%$ or better when the frequency meter is checked in terms of the crystal calibrator and the resulting correction applied to the dial reading.

Vacuum Tubes: The following tubes are used and are supplied with the instrument:

- 1-954
- 3-955
- 1-84/6Z4

Power Supply: Either 105 to 125 (or 210 to 250) volts, 50 to 60 cycles, or 6 and 180 volts d-c. A switch on the panel selects the type of power supply desired. The a-c operated power supply is built in. Batteries are not supplied with either the relay-rack or portable model.

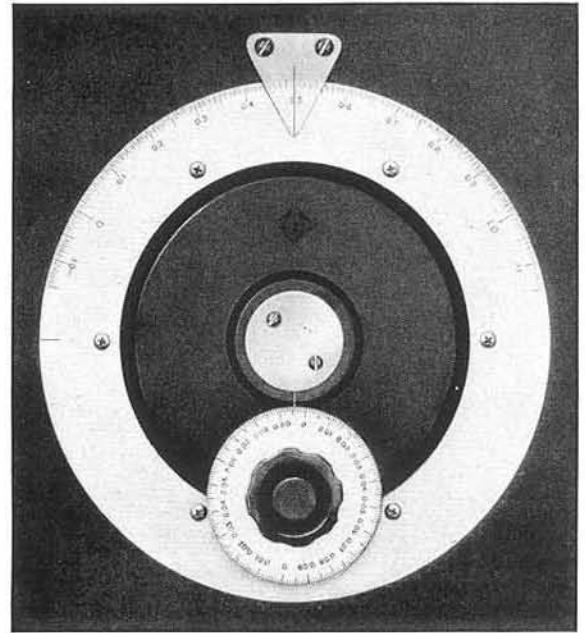

Closeup view of the tuning dial, showing details of the scale.

Power Input: 15 watts from 115-volt, 60-cycle supply.

Mounting: The instrument is supplied either for relay-rack mounting (TYPE 620-AR) or in a portable aluminum cabinet (TYPE 620-AM).

Accessories Supplied: One-megacycle quartz plate, line connector cord. With the relay-rack model (TYPE 620-AR) two multipoint connectors are furnished, while a battery plug and cable and a multipoint connector are furnished with the portable model (TYPE 620-AM).

Accessories Required: Head telephones, which can be connected either at the panel or at the rear of the instrument.

Dimensions: TYPE 620-AR, panel, (length) 19 x (height) 8 $\frac{3}{4}$ inches; behind panel, (length) 17 $\frac{1}{4}$ x (height) 8 $\frac{3}{8}$ x (depth) 11 $\frac{3}{4}$ inches; TYPE 620-AM, 20 $\frac{1}{2}$ x 14 $\frac{1}{2}$ x 10 inches, over-all.

Net Weight: TYPE 620-AR, 32 $\frac{3}{4}$ pounds; TYPE 620-AM, 47 $\frac{3}{4}$ pounds.

| Type | | Code Word | Price |
|--------|----------------------------|-----------|----------|
| 620-AR | Relay-Rack Model | DAISY | \$600.00 |
| 620-AM | Portable Model | DALLY | 680.00 |

PATENT NOTICE. See Notes 12, 20, page vi.

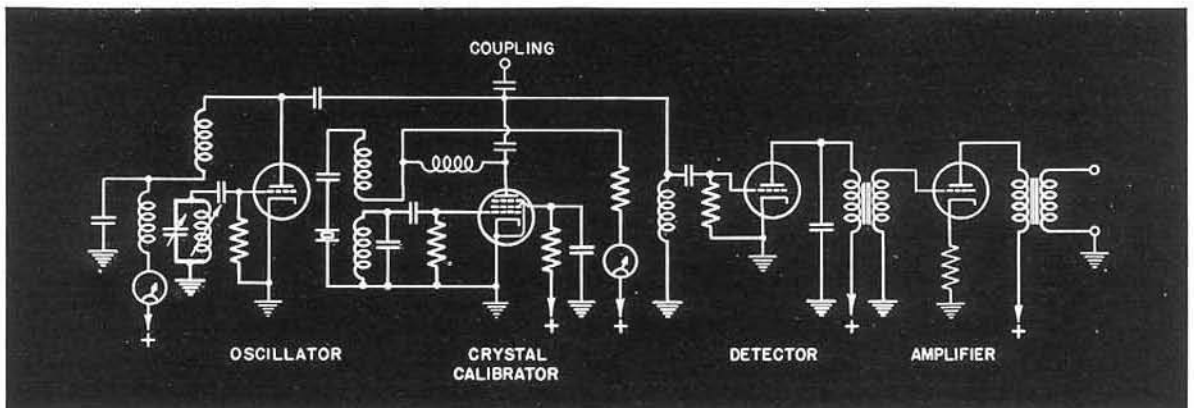

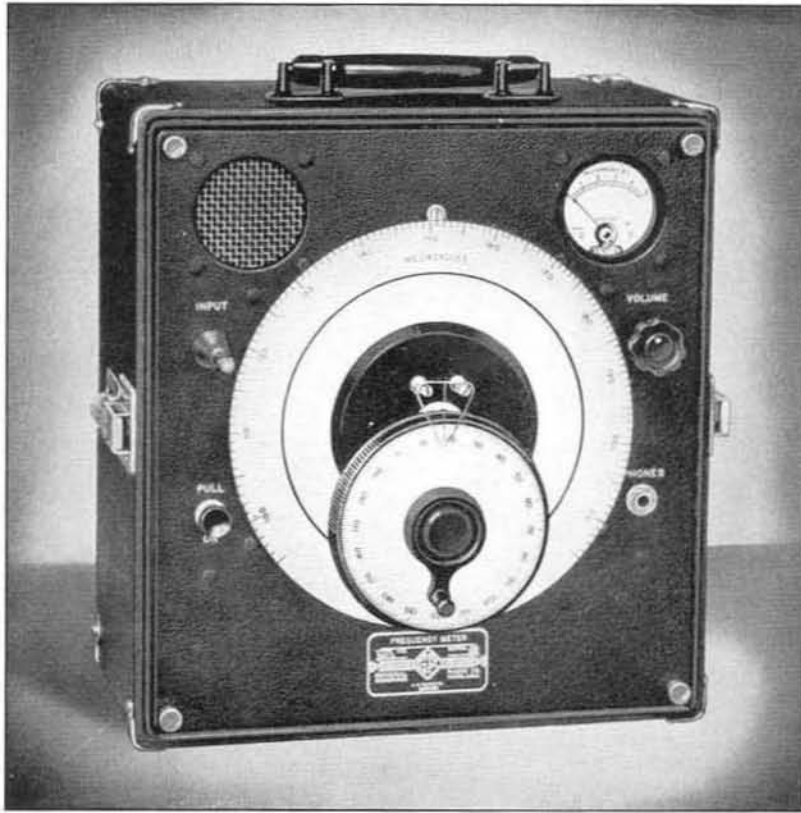

TYPE 720-A HETERODYNE FREQUENCY METER

USES: The TYPE 720-A Heterodyne Frequency Meter is used for the measurement of frequency in the h-f and u-h-f bands. It extends the field of the familiar heterodyne method of measurement up to about 3000 Mc.

DESCRIPTION: The principal elements of the instrument are a calibrated oscillator, a crystal detector and an audio amplifier. The frequency-determining element of the oscillator is a butterfly circuit, in which the capacitance and the inductance are varied simultaneously. The movable part of the circuit rotates in ball bearings. No sliding contacts are used, and no current is carried by the bearings. This permits a smooth and stable adjustment of frequency. The oscillator frequency is adjustable between 100 and 200 Mc. Harmonics of the oscillator are used to measure frequencies above 200 Mc, and harmonics of the unknown are used at frequencies below 100 Mc.

The detector is a standard silicon crystal, so mounted that it is easily accessible for replacement. A spare is furnished.

The three-stage audio amplifier has an effective band width of 50 kc. The output of the amplifier operates a panel meter and a

built-in loudspeaker. A jack is provided as well for head telephones.

The entire assembly is battery-operated, completely self-contained, and mounted in a portable, fabric-covered cabinet. Complete operating instructions are mounted in the cover of the cabinet.

FEATURES: ▶ The sensitivity obtainable with the heterodyne method of measurement permits this instrument to be used on comparatively weak signals.

▶ No direct connection to the source under measurement is usually required, because of the adjustable antenna mounted on the panel. However, provision is made for connecting an additional pickup wire if necessary.

▶ A wide range of frequencies can be measured with the single fundamental frequency band, and the dial arrangement is such that small frequency increments can be measured precisely.

▶ The butterfly type of tuned circuit avoids most of the difficulties inherent in variable-frequency elements at ultra-high frequencies.

▶ Either batteries or an a-c power supply can be used with the instrument.

SPECIFICATIONS

Frequency Range: The fundamental frequency range is from 100 to 200 megacycles. This range is covered in a single band with approximately logarithmic frequency distribution. By harmonic methods frequencies between 10 megacycles and 3000 megacycles can be measured. Since harmonics of the internal oscillator are considerably stronger than harmonics of the unknown as generated in the detector, the sensitivity of the instrument for frequencies below the range of the oscillator fundamental is considerably less than that at frequencies equal to or above the oscillator fundamental.

Beat Indication: With strong signals a strong beat note will be heard in the small dynamic speaker in the front panel. For weaker signals a pair of headphones should be used. In addition to the audible beat, a visual indication is obtained by the deflection of the panel meter. Since the band width of the detector circuit is 50 kilocycles, the panel meter will deflect even when the frequency measured is unstable and does not produce a steady audible beat note.

Calibration: The main dial is calibrated in frequency, each division corresponding to one megacycle.

The vernier dial is geared to the tuning unit to make one-half turn of the dial correspond to approximately 1% change in frequency over the entire tuning range. The vernier dial carries 200 uniform divisions.

Accuracy: The over-all accuracy of measurement is $\pm 0.1\%$.

Temperature and Humidity Effects: Over the range of room conditions normally encountered, temperature and humidity do not affect the accuracy of the instrument.

Vacuum Tubes: The following tubes are used and are supplied with the instrument:

- 1—1N5-GT/G
- 1—1DS-GT
- 1—958

Power Supply: A Burgess 6TA60 Battery is supplied with the instrument. For a-c operation the TYPE 1261-A Power Supply can be used (see page 102), but must be ordered separately.

Mounting: The TYPE 720-A Heterodyne Frequency Meter is mounted in a shielded carrying case of durable airplane-luggage construction. Complete operating in-

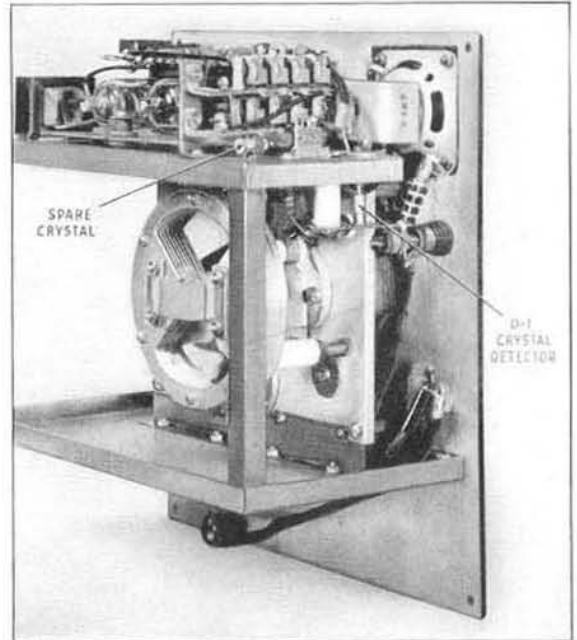

View of the butterfly-type tuned circuit used in the TYPE 720-A Heterodyne Frequency Meter.

structions are attached to the cover, and a complete wiring diagram, with circuit constants, is attached to the inside of the cabinet.

Accessories Supplied: One 1N21-B Crystal is supplied as a spare in addition to the one in the instrument.

Accessories Recommended: Headphones which can be plugged in on the front panel, and which can be stored in the cover of the instrument.

Dimensions: (Height) 14 x (width) 12 $\frac{1}{2}$ x (depth) 10 $\frac{1}{2}$ inches, over-all, including cover and handle. Panel, 10 $\frac{3}{4}$ x 11 $\frac{3}{4}$ inches.

Net Weight: 27 $\frac{1}{2}$ pounds, with battery.

| Type | Code Word | Price |
|---------------------------------------|-----------|----------|
| 720-A Heterodyne Frequency Meter..... | FANCY | \$340.00 |

PATENT NOTICE. See Note 10, page vi.

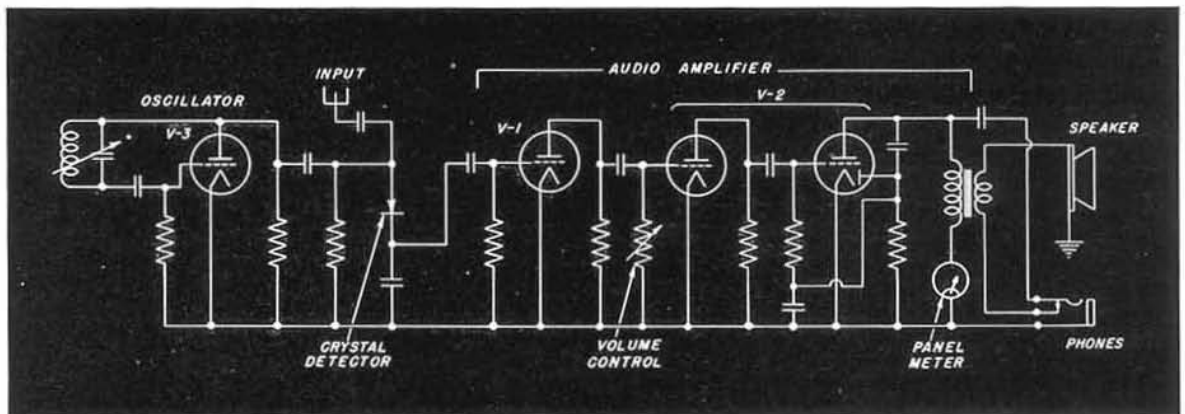

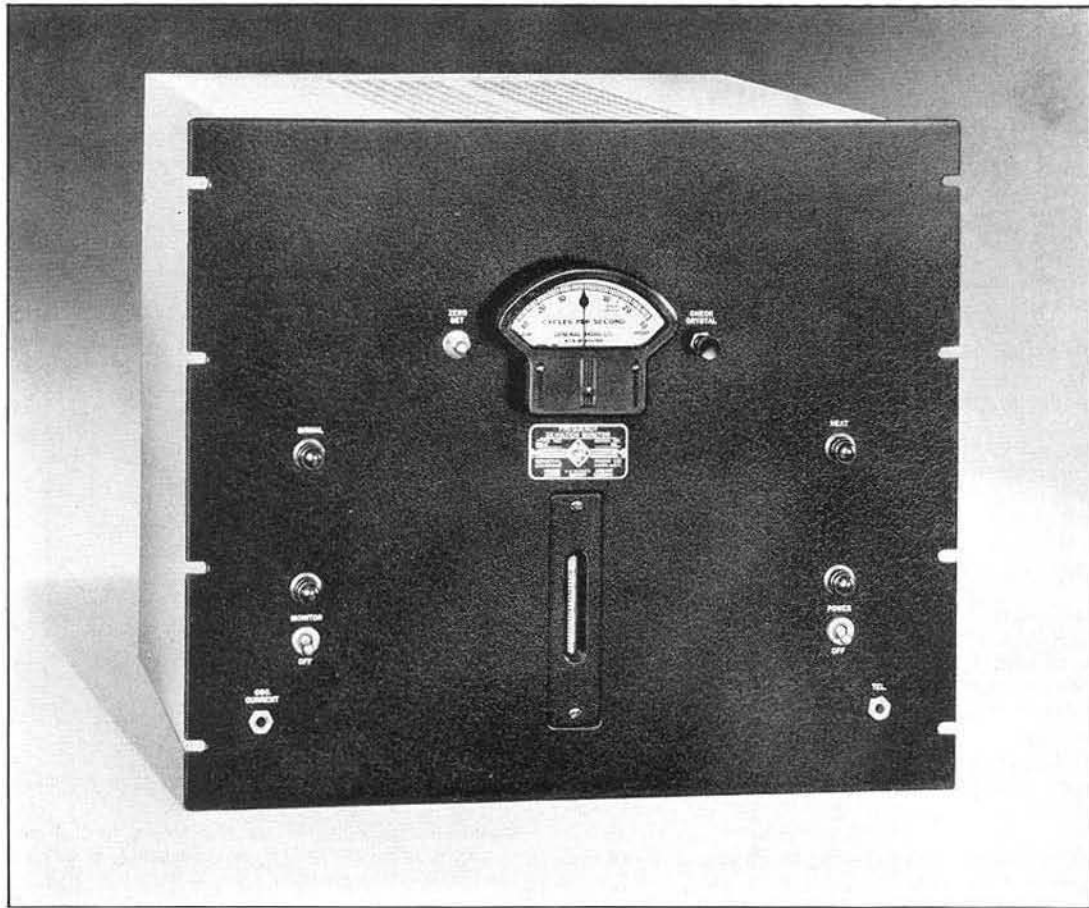

TYPE 1181-A FREQUENCY DEVIATION MONITOR FOR A-M TRANSMITTERS

USES: The TYPE 1181-A Frequency Deviation Monitor indicates directly the magnitude and direction of the frequency deviation of a broadcast transmitter from its assigned channel frequency. A monitor of this general type is required for each station by the Federal Communications Commission, and Approval Number 1467 has been issued by the Commission for the TYPE 1181-A.

DESCRIPTION: The elements of the monitor are shown in the accompanying schematic block diagram. Voltages from a temperature-controlled piezo-electric oscillator (frequency $f \pm 1000$ cycles) and the transmitter to be monitored (frequency $f \pm \Delta f$) are amplified and fed to a mixer from which their difference frequency ($1000 \pm \Delta f$) is obtained. This audio frequency is amplified, its peaks are clipped to produce an essentially square waveform, and the square waves are applied to an audio-frequency meter. The indicating element of the frequency meter is calibrated to read zero when the audio beat is exactly 1000 cycles per second. Deviations from 1000 cycles (Δf) are

indicated directly as the frequency deviation of the transmitter in cycles per second.

The monitor is a-c operated and is mounted on a single relay-rack panel. Coupling to the transmitter is obtained from a short length of wire attached to the input terminals to act as an antenna.

FEATURES: ▶ Modulation of the transmitter does not affect the frequency deviation indication. Consequently it is not necessary to couple the monitor to the crystal buffer stage of the transmitter, and the monitor input is obtained from the modulated transmitter output.

▶ Only a very small amount of r-f power is required to operate the monitor, and a simple pickup antenna — usually only a few inches of wire — is all that is needed.

▶ The frequency deviation indication is independent of carrier amplitude within wide limits.

▶ Positive indication of failure of either transmitter carrier or the monitor crystal oscillator

is provided. A signal-level pilot and the lamp in the indicating meter both are extinguished if the carrier input level drops too low for proper operation of the monitor. A push-button test indicates whether or not the monitor crystal voltage is adequate. Other pilot lamps indicate heater-thermostat and power circuit operation.

- ▶ Remote monitoring is possible by connecting an external meter to a socket provided at the rear of the instrument.
- ▶ Installation of the TYPE 1181-A Frequency Deviation Monitor is extremely simple, and the design is such that a minimum of attention is required from the station operating staff.

SPECIFICATIONS

Frequency Deviation Range: ± 30 cycles, readable to one cycle.

Carrier Frequency Range: 500 to 2000 kc.

Accuracy: When received, within ± 10 parts per million. An adjustment is provided to bring the reading into agreement with monitoring station measurements.

Stability: Under normal operating conditions, the frequency stability is better than one part in a million. Adjustments are provided to correct the indicated frequency in terms of standard-frequency transmissions whenever necessary.

Vacuum Tubes: The following tubes are required and supplied with the instrument:

- | | |
|--------|-------------|
| 3-6SJ7 | 1-5V4-G |
| 2-6AC7 | 1-6B4-G |
| 2-6H6 | 1-0C3/VR105 |
| 2-6SQ7 | 1-2050 |
| | 1-6V6 |

Coupling to Transmitters: A few inches of wire serving as an antenna is usually sufficient. A minimum of 50 millivolts pickup is required into a high-impedance grid circuit.

Accessories Supplied: Quartz plate, line connector cord, and plug for connecting an external meter.

Power Supply: 105 to 125 (or 210 to 250 volts), 50 to 60 cycles.

Power Input: 25 watts for heater circuits, 100 watts for monitor circuits.

Mounting: The instrument is relay-rack mounted.

Panel Finish: Standard General Radio black crackle. Certain standard grays which can be processed in quantity can be supplied at a price increase of \$11.00.

Dimensions: Panel (length) 19 x (height) 15 $\frac{3}{4}$ inches. Depth behind panel, 13 inches.

Net Weight: 51 pounds.

| Type | Code Word | Price |
|--|-----------|----------|
| 1181-A Frequency Deviation Monitor | MALAY | \$705.00 |

PATENT NOTICE. See Notes 7, 8, 12, 20, 26, page vi.

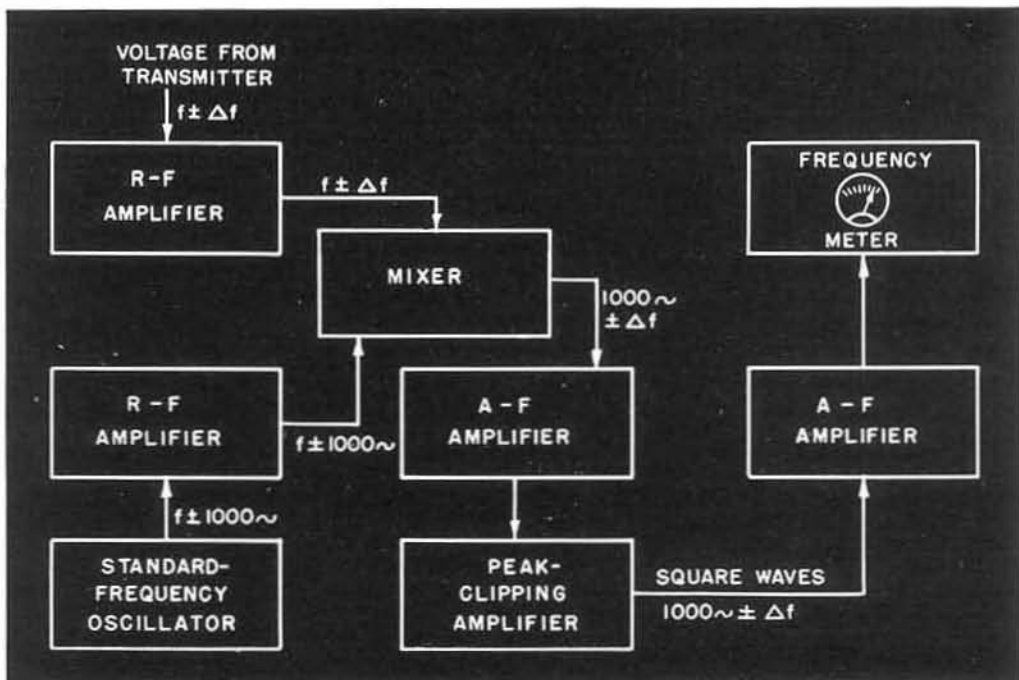

TYPE 1170-A F-M MONITOR

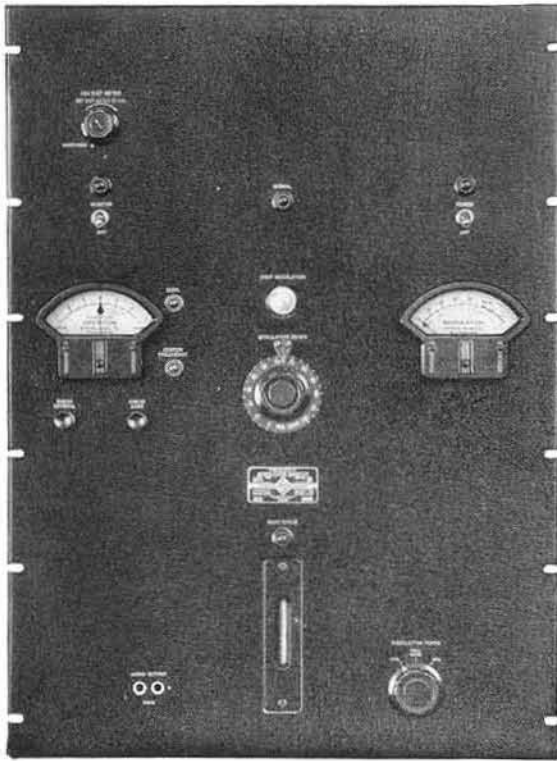

USES: This monitor gives a continuous indication of center-frequency and percentage modulation (frequency deviation) of f-m transmitters. It also furnishes a high-fidelity output for measuring distortion and noise, and a 600-ohm output for audio monitoring. The monitor is designed to operate at frequencies between 30 and 220 megacycles, covering both the f-m broadcasting bands and the frequencies used for audio transmitters in television broadcasting.

DESCRIPTION: The accompanying block diagram shows the functional operation of the monitor. A harmonic of a standard-frequency oscillator beats with the transmitter frequency to produce a nominal intermediate frequency of 150 kc plus or minus the transmitter frequency deviations. This signal is then passed through amplifiers and limiters which change the waveform to steep, square-topped pulses

of constant amplitude, which are applied to a counter-type discriminator. The d-c output of the discriminator is used to operate the center-frequency indicator. The a-c output, suitably amplified and filtered, operates the modulation indicators and is available at two output circuits: a 100,000-ohm circuit for distortion and noise measurements and a 600-ohm circuit for audio monitoring.

FEATURES: ▶ The use of a low intermediate frequency and a counter-type discriminator results in a high degree of stability, so that a continuous indication of center frequency is achieved without reference to a second crystal for setting zero.

▶ Highly stable crystal oscillator. Same circuit as is used in GR a-m monitors.

▶ Because the counter-type discriminator is inherently linear, accurate center-frequency indications are obtained even in periods of heavy modulation.

▶ Discriminator is linear to better than 0.1%, permitting accurate distortion measurements.

▶ Can be operated at 25 kc = 100% modulation, for television audio channels.

▶ Distortion-and-noise-measuring output includes standard 75 microsecond de-emphasis circuit.

▶ Residual noise level is down at least 75 db referred to ± 75 kc deviation, and 65 db for ± 25 kc (television) deviation.

▶ Modulation meter reads positive or negative peaks or peak-to-peak, as selected by a switch.

▶ Overmodulation lamp flashes when modulation exceeds level as set by a dial.

▶ R-F sensitivity is 1.0 volt or better.

▶ Adjustable input attenuator, with input level meter.

▶ Pilot lamp indicates when input level is adequate.

▶ Terminals are provided for connecting external meters and overmodulation indicators.

▶ Regulated power supply.

▶ Chassis arranged for maximum heat dissipation and easy servicing.

▶ A zero correction is provided to compensate for long-time drift.

SPECIFICATIONS

Transmitter Frequency Range: 30 to 162 Mc with Type 1170-P1 R-F Tuning Unit; 160 to 220 Mc with Type 1170-P2 R-F Tuning Unit.

R-F Input Impedance: High impedance, with Type 774 Coaxial Connector. A capacitance attenuator is provided for adjusting the input level. The monitor can be used with standard R M A transmitter monitoring output.

Input Sensitivity: 1 volt r-f, or better.

Input Level Indicators: A meter for indicating r-f input level is provided at the rear of the chassis. Signal pilot lamp and center-frequency-meter pilot glow when input level is adequate, and are extinguished when level drops below the usable minimum.

Intermediate Frequency: 150 kc.

Discriminator: Pulse-counter type, linear to better than 0.1% over a range of ± 100 kc (133% modulation).



Center Frequency:

Indication: Meter is calibrated in 100-cycle divisions from -3000 to +3000 cycles per second. No zero set is necessary for each reading and no second crystal is provided.

Accuracy: Crystal frequency, when monitor is received, is within ± 10 parts per million of specified channel frequency. Center-frequency reading is adjustable over ± 3000 -cycle range to bring monitor into agreement with frequency-measuring service. Center-frequency indication then is accurate to ± 200 cycles.

Stability: ± 400 parts per million, or better, over-all, for long periods.

Percentage Modulation:

Indication: Meter is calibrated from 0 to 133%. Additional db scale is provided. Switch selects positive or negative peaks, or full-wave (peak-to-peak) indication. 100% modulation corresponds to 75 kc deviation for f-m bands. Internal adjustment of meter circuit changes calibration to read 100% at 25 kc deviation, for television audio monitoring. Meter ballistics meet FCC requirements.

Accuracy: $\pm 5\%$ modulation.

Overmodulation Indicator: Lamp flashes when predetermined modulation level, as set on a dial, is exceeded. Range of dial is 0 to 120% modulation.

Output Circuits:

1. Distortion and Noise Measurements: Terminals are provided for connecting a TYPE 1932 Distortion and Noise Meter, and a gain control is provided.

Residual Distortion: Less than 0.2% at 100-kc swing (133% modulation).

Response: 50 to 30,000 cycles per second $\pm 1/2$ db. Standard 75 microsecond de-emphasis circuit is included.

Maximum Output: 1.5 volts into 100,000 ohms.

Residual Noise Level: -75 db or better referred to 75 kc deviation; -65 db or better for 25 kc deviation.

Sensitivity: Full output can be obtained down to 8% of 75 kc deviation. Sensitivity varies with modulation frequency in accordance with standard de-emphasis characteristic.

2. Audio Monitoring Output:

Impedance: 600 ohms, unbalanced.

Output: Zero dbm at 75 kc deviation, 100% modulation.

Response: 50 to 15,000 cycles per second $\pm 1/4$ db.

Crystal Oscillator: General Radio high-stability circuit. Crystal is temperature-controlled at $(60 \pm 0.15)^\circ$ C. Temperature coefficient of crystal is 2 parts per million or less per degree C. Crystal oscillator output level can be read on panel meter by pressing a push-button switch. A jack is mounted at the rear of the chassis for connecting a milliammeter to check crystal oscillator plate current.

Remote Indicators: Circuits and terminals are provided for connecting the following indicators externally:

- Center-frequency indicator
- Percentage-modulation meter
- Over-modulation lamp
- 600-ohm unbalanced aural monitor

Vacuum Tubes: The following tubes are used and are supplied with the monitor:

- | | |
|-----------|-------------|
| 1-6AK6 | 2-6C4 |
| 2-6AG7 | 1-S15 |
| 1-6AB7 | 2-0D3/VR150 |
| 2-6SN7-GT | 1-6J6 |
| 1-6BE6 | 1-991 |
| 1-6AG5 | 1-6SK7 |
| 2-2050 | 1-6AS7-G |
| 1-6SJ7 | 1-0C3/VR105 |
| 6-6AL5 | 2-3-4 |
| 4-6SL7-GT | |

Accessories Supplied: All tubes, coaxial connector for r-f input, power line connection cord, power supply plug.

Power Supply: 105 to 125 volts, 50 to 60 cycles. Power-transformer-primary connections can be changed to permit operation on 210 to 250 volts. Rated power input 300 watts.

Mounting: 19-inch relay-rack panel with dust cover.

Panel Finish: Standard General Radio black crackle lacquer. Certain standard grays and other finishes that can be processed in quantity can be furnished at an extra charge of \$20.00.

Dimensions: Panel, 19 x 26 1/4 inches, depth behind panel, 13 1/4 inches, over-all.

Net Weight: 88 pounds.

| Type | Code Word | Price |
|----------------------|-----------|-----------|
| 1170-A F-M Monitor | AHEAD | \$1625.00 |

PATENT NOTICE. See Note 1, page vi.

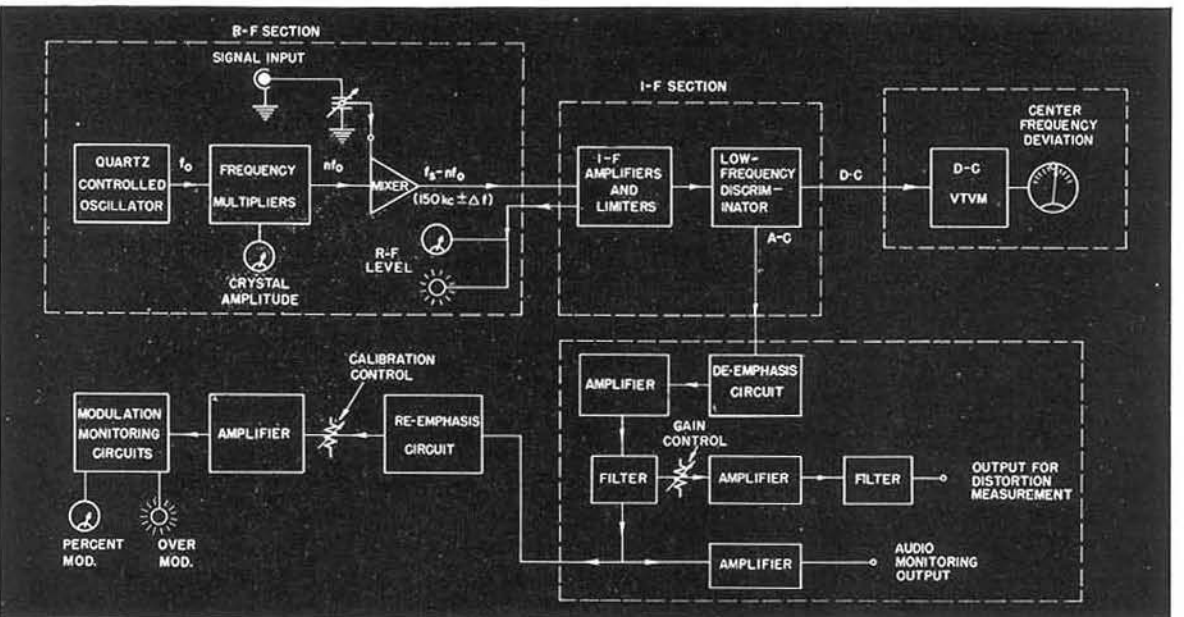

FREQUENCY

TYPE 1175-B FREQUENCY MONITOR



USES: The TYPE 1175-B Frequency Monitor is designed to monitor the carrier frequency of amplitude-modulated radio transmitters in the high-frequency range, particularly those operated by police, fire, and other municipal departments. It is a high-sensitivity monitor and hence can be used to monitor low-frequency mobile transmitters from a distance as well as for monitoring the main transmitter.

Used either singly or in groups, it provides an excellent means of monitoring the frequencies used by airlines and airports.

Television transmitters operating at frequencies up to 220 megacycles can use the TYPE 1175-BT Frequency Monitor for continuously monitoring the video carrier frequency.

A voltage of the audio beat frequency is available at an output jack. Where a continuous indication of frequency deviation is desired, the TYPE 1176-A Frequency Meter should be used.

DESCRIPTION: The monitor consists of a temperature-controlled piezo-electric oscillator with mounting facilities for 4 crystals; 2 buffer amplifiers, one for the crystal frequency and one for the transmitter frequency; a mixer; and an audio-frequency amplifier. In the TYPE 1175-BT Frequency Monitor the crystal buffer amplifier is tuned and so the monitor becomes essentially a single-channel instrument although four crystals can be mounted in the oven.

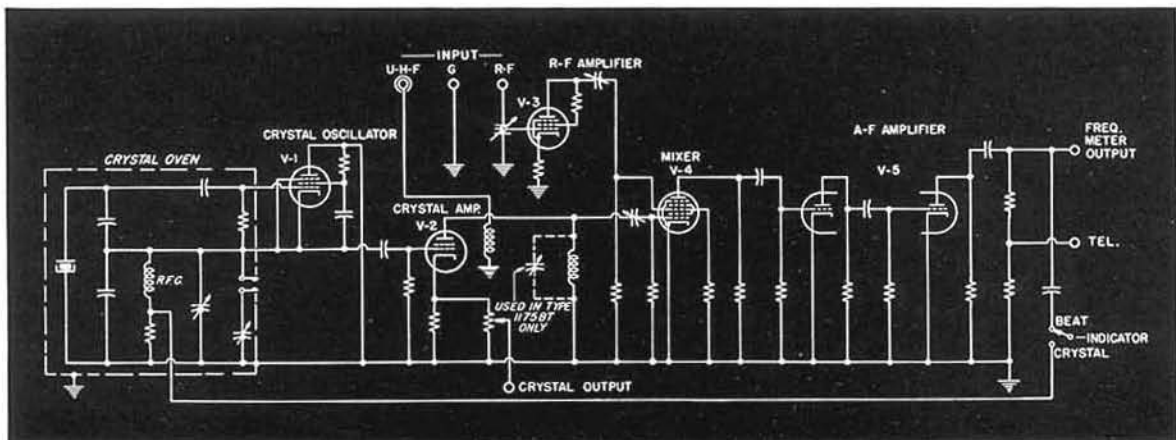

The crystal oscillator circuit is one developed in the General Radio laboratories specifically for use in monitoring where a high degree of stability and reliability is required. It differs from older types in one important respect: no tuned elements are used in the circuit except the crystal itself. The crystal operates much nearer to its true series resonant frequency than is possible in conventional circuits, and the stability achieved is correspondingly higher.

The beat-frequency output is available at a telephone jack on the panel, and the output of the crystal oscillator is available at panel terminals for calibrating or adjusting other equipment, such as receivers and mobile transmitters. A low-pass filter is provided with the TYPE 1175-BT for use between the monitor and the TYPE 1176-A Frequency Meter. This filter is used to eliminate the picture line-frequency component of 15,750 cycles and its harmonics.

A panel switch allows the monitor to be kept in a stand-by condition, where the vacuum-tube circuits are not operating but temperature control is maintained.

FEATURES: ▶ Television transmitter-frequency monitoring on all channels from 1 to 13, inclusive, is simple and convenient with this monitor.

▶ The high sensitivity of the monitor makes it possible to use it for low-power services and remote monitoring.

▶ Crystal oscillator output is available at panel terminals and an output level control is provided.

▶ Two buffer stages are used, one for the crystal oscillator and one for the transmitter input.

▶ Stand-by operation is available by simply turning a switch on the panel.

▶ A test for deviation direction is provided, as well as tests for crystal and beat output.

▶ Deviation frequency magnitude, completely unaffected by amplitude modulation of the transmitter carrier, is given directly when a TYPE 1176-A Frequency Meter is used with the monitor.

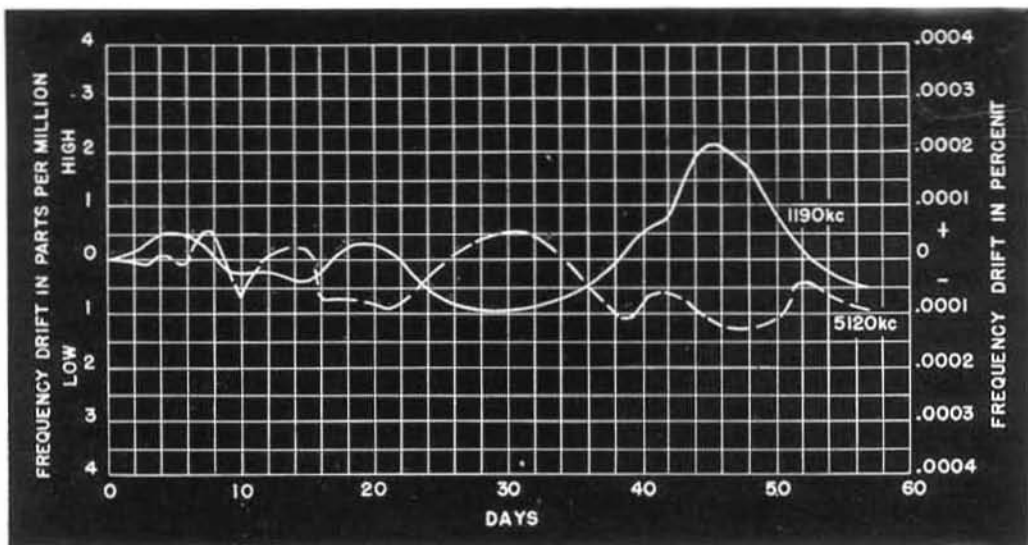

Actual records of crystal oscillator stability over a period of several weeks. The frequencies indicated on the plot are fundamentals; harmonics are used for monitoring.

SPECIFICATIONS

Carrier Frequency Range: 1600 kc to 162 Mc for TYPE 1175-B; 1600 kc to 220 Mc for TYPE 1175-BT.

Accuracy: With TYPE 376-M Quartz Plate, 0.001%.

Quartz Plate: No crystals are included in the price. See price list below. Crystals are ground to an integral sub-multiple of the channel frequency, unless offset operation is specified.

Number of Monitoring Channels: A maximum of four different channels for TYPE 1175-B; one only for TYPE 1175-BT.

Power Supply: 105 to 125 volts, 50 to 60 cycles. By

changing connections on the power transformer, the monitor can be operated from a 210- to 250-volt line.

Power Input: 75 watts, including temperature control.

Accessories Supplied: Line connector cord, multi-point connector, and TYPE 774-M Cable Jack.

Vacuum Tubes:

- | | |
|-----------|-------------|
| 1-6AC7 | 1-6SJ7 |
| 1-6AG7 | 1-6X5 |
| 1-6E5 | 1-6BE6 |
| 1-6SN7-GT | 1-0D3/VR150 |

All vacuum tubes are supplied.



FREQUENCY

Panel Finish: Standard General Radio black crackle. Certain standard grays which can be processed in quantity can be supplied at a price increase of \$11.00.

Mounting: Standard 19-inch relay-rack panel. Walnut end frames are available for adapting the instrument

for table mounting. (See price list below.)

Dimensions: Panel, 19 x 7 inches; depth behind panel, 11 1/4 inches.

Net Weight: 22 pounds.

| Type | | Code Word | Price |
|-------------|--|------------|------------|
| 1175-B | Frequency Monitor 1600 kc to 162 Mc | TIPSY | \$325.00 |
| 1175-BT | Frequency Monitor 1600 kc to 220 Mc | TUNIC | 340.00 |
| 376-M | Quartz Plate | LABOR | 70.00 |
| ZFRI-410-P1 | End Frames for Type 1175-B (or -BT) | ENDFRAMDAY | 16.50 pair |
| ZFRI-710-P5 | End Frames for Type 1176-A mounted with Type 1175-B (or -BT) as a single unit . . | ENDFRAMGAS | 17.00 pair |

PATENT NOTICE: See Notes 1, 8, 12, 20, page vi.

TYPE 1176-A FREQUENCY METER



USES: The TYPE 1176-A Frequency Meter can be used as a general-purpose instrument for determining the frequency of an unknown source, or continuously monitoring the frequency of a system.

For the electronics laboratory it provides a convenient means of measuring audio and supersonic frequencies up to 60 kc, regardless of waveform. For monitoring radio transmitters, it can be used in conjunction with a crystal monitor, such as the TYPE 1175-B, to indicate continuously the deviation from assigned channel frequency.

DESCRIPTION: The circuit consists of (1) an input amplifier followed by (2) a series of clipping and limiting amplifiers, and (3) a frequency-indicating circuit composed of a capacitor, a diode, and a d-c microammeter. The function of the clippers and limiters is to convert the input signal to a square waveform

so that the indication is not affected by changes in amplitude or waveform of the input signal.

FEATURES: ▶ Direct-reading scales, and a single range-selector switch, permit rapid frequency measurements to be made.

▶ A well-regulated power supply eliminates all effects of line voltage changes.

▶ Individual scale calibration adjustments are provided for each range.

▶ An external meter can be connected to the instrument through a multipoint connector on the rear of the unit.

▶ Two sets of input terminals are provided on the panel and, on the rear of the unit, a multipoint connector provides a means of attaching more permanent connections. Plugging into the W. E. panel jacks automatically disconnects the rear terminals.

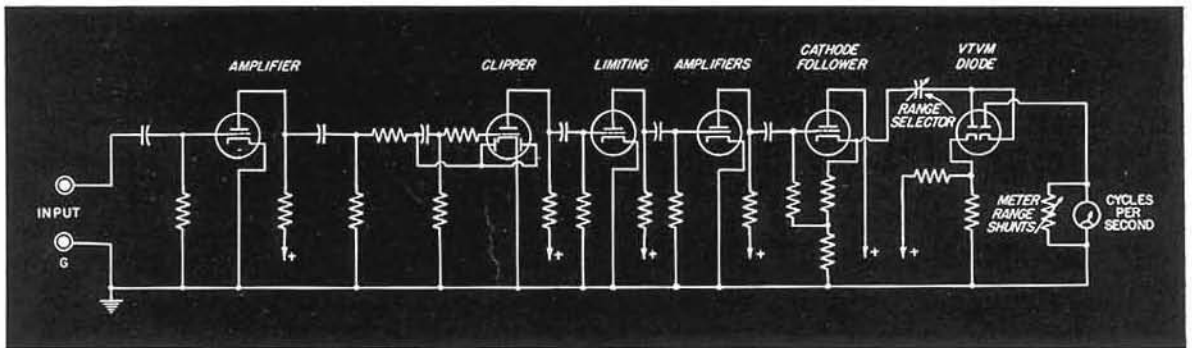

SPECIFICATIONS

Range: 25-60,000 cycles per second in six ranges. Full-scale values are 200, 600, 2000, 6000, 20,000, 60,000 cycles.

Accuracy: $\pm(2\%$ of full scale + 2 cycles), for all ranges. When operating on the 60,000-cycle range, with less than 0.5 volt input, the accuracy becomes $\pm 3\%$ of full scale.

Input Voltages: 0.25-150 volts.

Input Resistance: 500,000 ohms, for all ranges. One side grounded.

Input Waveform: The readings are substantially independent of waveform, so long as the dissymmetry of the positive and negative portions of the wave is less than 8:1.

Power Supply: 105-125 (or 210 to 250) volts, 50-60 cycles.

Power Input: 50 watts.

Vacuum Tubes:

- 1-6H6
- 1-6SQ7
- 1-6X5
- 1-6V6
- 1-6SN7-GT
- 1-6J5
- 2-6SJ7
- 1-0A3/VR75

1-Amperite 3-4

All vacuum tubes are supplied.

Mounting: Standard 19-inch relay-rack panel; walnut end frames are available to convert to table mounting. (See price list below).

Panel Finish: Standard General Radio black crackle. Certain standard grays which can be processed in quantity can be supplied at a price increase of \$11.00.

Accessories Supplied: Line connector cord and multi-point connector.

Dimensions: Panel, 19 x 5 1/4 inches, depth behind panel, 11 1/4 inches.

Net Weight: 19 1/2 pounds.

| Type | | Code Word | Price |
|-------------|--|------------|------------|
| 1176-A | Frequency Meter | TIM1D | \$265.00 |
| ZFRI-310-P1 | End Frames for Type 1176-A | ENDFRAMCAT | 16.50 pair |
| ZFRI-710-P5 | End Frames for Type 1176-A mounted with Type 1175-B (or -BT) as a single unit . . | ENDFRAMGAS | 17.00 pair |

PATENT NOTICE. See Notes 1, 26, page vi.

The TYPE 1175-B Frequency Monitor and the TYPE 1176-A Frequency Meter are shown here assembled with end frames for use as a deviation monitor. Either instrument can be purchased and used separately.



TYPE 1141-A AUDIO-FREQUENCY METER



USES: The TYPE 1141-A Audio-Frequency Meter is a convenient instrument for measuring the frequency of oscillators and other audio-frequency signal sources. In radio-frequency measurements it can be used to measure the frequency of the audio beat between the unknown frequency and a 10-kilocycle standard-frequency harmonic.

DESCRIPTION: This meter uses the Wien bridge frequency-selective circuit with a null method of identification. The bridge circuit contains only capacitances and resistances. The calibrated dial controls a ganged assembly

of two precision variable resistors, while the changes in range are accomplished by switching the fixed capacitors.

FEATURES: ▶ Very accurate audio-frequency measurements can be made easily.

▶ A wide frequency range from 20 to 20,000 cycles is covered in three decade ranges.

▶ A logarithmic dial scale is made possible by using variable resistors with tapered elements.

▶ Magnetic pickup is negligible because the circuit uses only resistances and capacitances.

SPECIFICATIONS

Frequency Range: 20 to 20,000 cycles in three ranges, 20 to 200 cycles, 200 to 2000 cycles, and 2000 to 20,000 cycles.

Accuracy: $\pm 0.5\%$ over the entire frequency range. The null point is sharp enough so that the dial can be set to 0.1% provided the waveform is reasonably pure and the supply voltage or detector sensitivity is sufficiently high to provide the necessary over-all sensitivity.

Dial: The 6-inch dial, which has a slow-motion drive, turns through an angle of about 320° giving a scale

length of about 17 inches for each 10 to 1 frequency range. The total scale length is thus over 4 feet.

Input Impedance: 3 to 10 kilohms, the smaller value corresponding to the higher frequencies.

Input Voltage: 110 volts rms, maximum.

Output Impedance: 1 to 4 kilohms, the smaller value corresponding to the higher frequencies.

Controls: Frequency dial, range selector switch, and resistance-balance control.

Accessories Required: A null detector is needed to operate the meter. Head telephones, such as the Western Electric 1002-C, or an amplifier-meter combination, such as the TYPE 1231-B Amplifier and Null Detector, can be used. Even with head telephones an amplifier and filter section will prove useful.

Mounting: The instrument is mounted on an aluminum panel in a shielded cabinet.

Dimensions: (Length) 12 x (width) 8¾ x (height) 9 inches over-all.

Net Weight: 15¼ pounds.

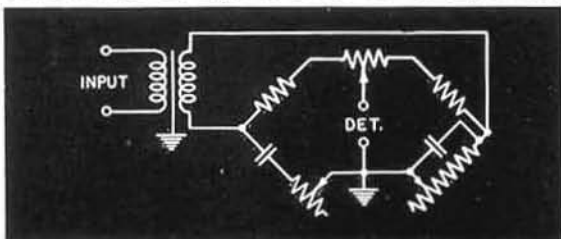

| Type | Code Word | Price |
|------------------------------------|-----------|----------|
| 1141-A Audio-Frequency Meter | COLOR | \$215.00 |

PATENT NOTICE. See Note 18, page vi.



TYPE 815 PRECISION FORK

USES: The TYPE 815 Precision Fork is designed for such uses as timing in geophysical exploration, rating clocks and watches, synchronizing facsimile transmission, and low-frequency standardization. It is also an excellent source for accurately timing stroboscopic flashes.

DESCRIPTION: The fork is made of low-temperature-coefficient stainless steel. It is mounted at the heel on a metal panel which is attached to the main base by means of rubber shock absorbers to reduce energy dissipation through the mounting. The fork is driven by an electromagnet mounted between the tines.

Separate microphone buttons are used for the driving and output circuits. One microphone button is mounted on each tine near the heel of the fork, where the amplitude of vibration is low. This minimizes the damping action which the presence of the microphones exerts on the fork. At the end of each tine, adjusting screws are provided for equalizing the loading on the tines, an important factor in reducing the decrement.

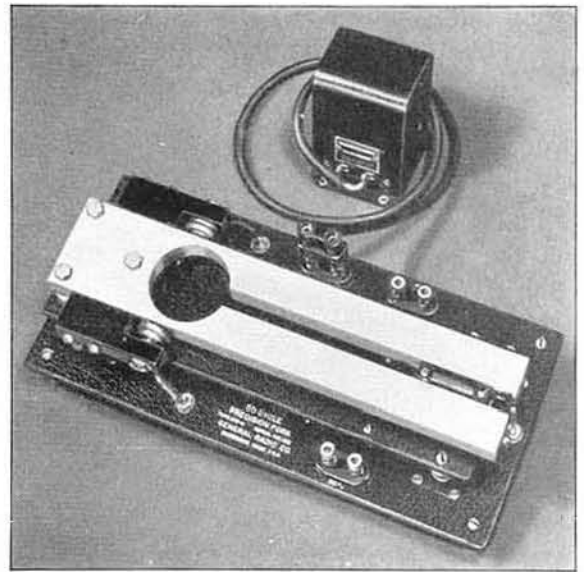

FEATURES: ▶ Accuracy and stability are combined with simplicity of construction and operation.

▶ Small size and low power requirements make the fork easily portable.

SPECIFICATIONS

Frequency: Three models, operating at 50, 60, and 100 cycles, respectively, are listed.

Calibration: The fork will be exactly on frequency at some temperature between 70 and 80 degrees Fahrenheit. The measured value, with a driving voltage of 4 volts, at a stated temperature between 70 and 80 degrees Fahrenheit is given on the calibration certificate to $\pm 0.001\%$.

Stability: The over-all stability of the fork is about 1 part in 10,000 under normal operating conditions.

Temperature Coefficient: Between 60 and 80 degrees Fahrenheit the temperature coefficient of frequency is about 0.001% per degree Fahrenheit and is negative. The actual measured value is given on the calibration certificate.

Voltage Coefficient: The voltage coefficient of frequency is about 0.005% per volt and is given for each fork on the calibration certificate.

Waveform: Harmonics are about 30% of the output voltage at all loads.

Output: The internal output impedance is about 50 ohms, and the maximum output power about 25 milliwatts when a 6-volt battery is used in the output circuit. The TYPE 815-P1 Transformer has a step-up ratio of 1 to 27.8 and an open-circuit output of about 50 volts can be obtained from it when connected to the fork output. This transformer is recommended for use between

the fork output and any relatively high load impedance such as the input to a power amplifier.

Power Supply: A 4-volt battery is recommended as the driving source and a 4- to 6-volt battery in the output circuit. The battery can be common to both circuits. Driving current is less than 50 milliamperes.

Accessories Supplied: A "phasing" capacitor with plug-in leads.

Mounting: The fork assembly is mounted on a metal base, which should be horizontal when the fork is operating.

Dimensions: 13 x 6 x 3 inches, over-all.

Weight: 10 $\frac{3}{4}$ pounds.

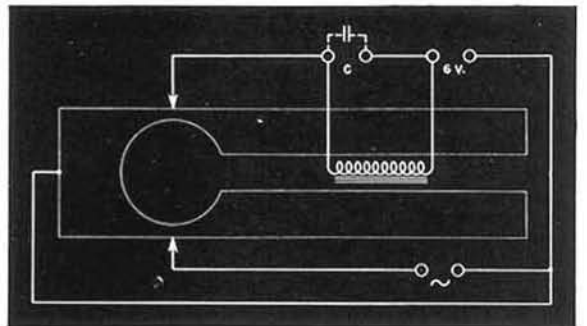

| Type | Frequency | Code Word | Price |
|--------|------------------|-----------|----------|
| 815-A | 50 cycles..... | FAUNA | \$195.00 |
| 815-B | 60 cycles..... | FATAL | 195.00 |
| 815-C | 100 cycles..... | FELON | 195.00 |
| 815-P1 | Transformer..... | TARDY | 12.00 |

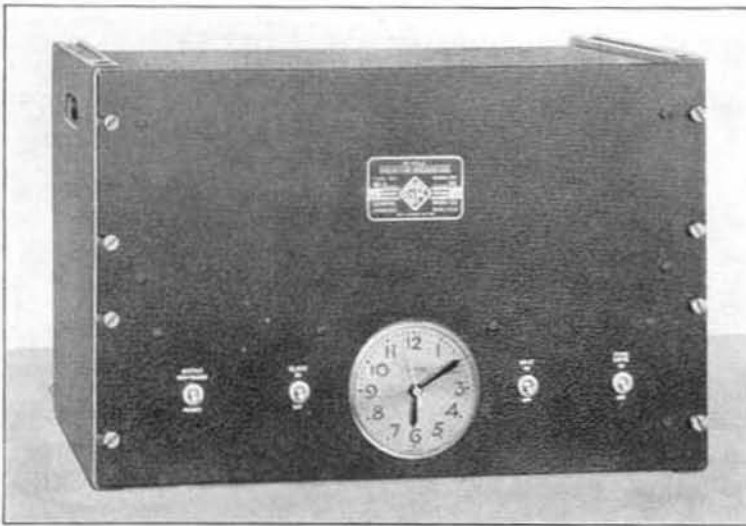

**TYPE 816
VACUUM-TUBE
PRECISION FORK**

USES: The TYPE 816 Vacuum-Tube Precision Fork is a primary standard of frequency. It can be used for the same purposes as TYPE 815 Precision Fork but its higher precision and stability make it adaptable to considerably more accurate measurements and, in addition, to timekeeping and chronographic measurements.

DESCRIPTION: The complete instrument consists of a tuning fork similar to that used in TYPE 815 Precision Fork, a temperature control system, a vacuum-tube amplifier, and a synchronous motor clock. The fork is made of low-temperature-coefficient stainless steel. It is mounted at the heel on a metal panel, which is attached to the base of the temperature-control box by means of four vertical helical springs to reduce energy dissipation through the mounting. The fork is driven electro-magnetically, and the drive and pickup coils are symmetrically placed with respect to the tines in order to keep the decrement low and give a Q of the order of 20,000.

A two-stage amplifier couples the pickup and the driving coils. An a-v-c circuit is

included, and a fourth vacuum tube supplies output power at the fork frequency. The general circuit is shown in the accompanying schematic diagram.

The temperature-controlled chamber in which the fork is mounted is a metal box enclosed in a balsa-wood case.

The synchronous clock is designed to register correct time when the fork is exactly on its rated frequency. Comparison of the readings of this clock with standard time signals as transmitted by radio provides a means of checking the frequency of the fork over 24-hour periods of continuous operation.

FEATURES: ▶ Excellent accuracy and a high degree of frequency stability are the important characteristics of this fork.

▶ Power output is kept constant and a number of convenient output impedances are available for connection to various loads.

▶ The hour and minute hands are resettable from the rear of the instrument.

▶ Power for running the fork can be obtained from either an a-c or d-c source, so field as well as laboratory operation is possible.

SPECIFICATIONS

Frequency: 50 cycles per second or 60 cycles per second.

Calibration: The frequency is adjusted within 0.0005% of its rated value and is measured to 0.0001% in our standardizing laboratory.

Screws are provided in the ends of the tines of the fork for adjusting the frequency. These are accessible from the outside of the temperature-control box. Minute changes are accomplished by adjusting the a-v-c circuit while in operation.

Stability: When the temperature-control system is operating, the frequency is within one part in 100,000 (0.001%) of its mean value, thus timing to better than

(Right) Plot of a 10-day frequency record of TYPE 816 Vacuum-Tube Precision Fork. The full line shows the observed frequency, the dotted line the frequency after the barometer correction was applied.

one second per day. Without temperature control, the frequency will follow (with a considerable lag) variations in ambient temperature. At ordinary room temperatures, the temperature coefficient of frequency is negative and is between 10 and 20 parts in 10^6 per degree

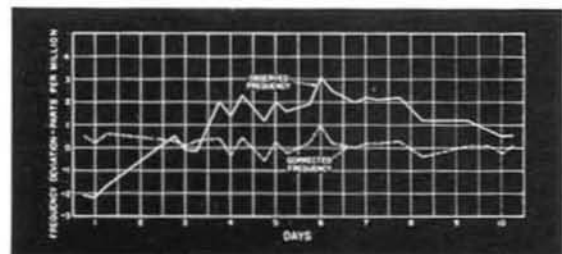

Centigrade. This coefficient is smaller at the controlled operating temperature. Frequency changes with supply voltage and atmospheric pressure are usually negligible in comparison to the rated accuracy of the fork.

Power Supply: The amplifier circuit and the heaters for temperature control are arranged to operate on either of two types of power supply, selection being made by plug and jack terminals:

- (1) a-c line, 105 to 125 volts, 50 to 60 cycles.
- (2) d-c line, 105 to 125 volts.

Power Input: For temperature control, 30 watts, intermittent; for fork and amplifier, 45 watts, constant. Separate line switches control the heater and fork circuits.

Output: Peaked or sinusoidal, as selected by a switch. When the synchronous clock is operated, maximum output is 1 watt. When clock is not used, maximum output is 2 watts. Output circuit is not grounded and is free from any d-c polarization. Various output impedances between 200 and 30,000 ohms are provided. Operating frequency is not affected by change in output load.

Maximum peaked open-circuit output voltage is 350 volts.

Tubes: Supplied with instrument:

- 2—6J7-G
- 1—6Q7-G
- 1—25L6-GT/G
- 1—25Z6
- 1—TYPE 2LAG-949A

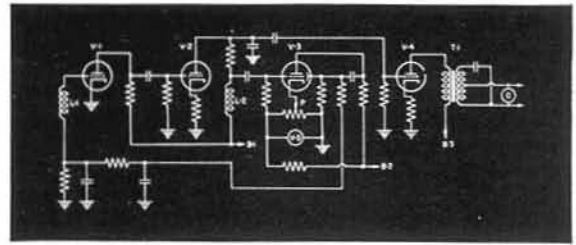

Schematic circuit diagram of the fork amplifier and output circuits. L_1 and L_2 are the pickup and driving coils.

Accessories Supplied: Spare fuses, multipoint connector, line connector cord.

Mounting: The entire assembly is mounted on a standard 19-inch relay-rack panel, which can be adapted for table mounting by the use of the wooden end frames supplied. The instrument is readily portable in an operating condition if kept in approximately its operating position (panel vertical).

Dimensions: Panel, 19 x 12 1/4 inches; depth, 12 1/2 inches.

Net Weight: 56 pounds.

| Type | Frequency | Code Word | Price |
|-------|-----------|-----------|----------|
| 816-A | 50 c | FERRY | \$575.00 |
| 816-B | 60 c | FABLE | 575.00 |

TYPE 566-A WAVEMETER

USES: The TYPE 566-A Wavemeter is a wide-range, general-purpose, absorption-type instrument intended for rapid frequency checks in the laboratory or the field.

DESCRIPTION: The wavemeter consists of a variable air capacitor mounted in a walnut cabinet, a set of five plug-in inductors, and an incandescent lamp, which is used to indicate resonance. A friction-type slow-motion-drive dial is provided on the capacitor and carries three scales calibrated directly in frequency.

FEATURES: ▶ Compactness and moderate price are important features of this wide-range wavemeter.

▶ The plug-in terminals are so arranged that the inductor can be rotated to vary the coupling to the source under measurement.

▶ A rack is provided on the side of the cabinet for storing the coils when the wavemeter is not in use.



SPECIFICATIONS

Frequency Range: 0.5 to 150 Mc (600 to 2 meters) using the five plug-in inductors furnished with the instrument. The capacitor dial is direct reading in frequency.

Accuracy: The accuracy of dial indication is $\pm 2\%$, 0.5 to 16 Mc; and $\pm 3\%$, 16 to 150 Mc.

Accessories Supplied: One spare indicator lamp.

Dimensions: 4 3/4 x 5 3/8 x 5 3/4 inches, over-all.

Net Weight: 3 pounds.

| Type | Code Word | Price |
|-------|-----------|---------|
| 566-A | WAGON | \$60.00 |



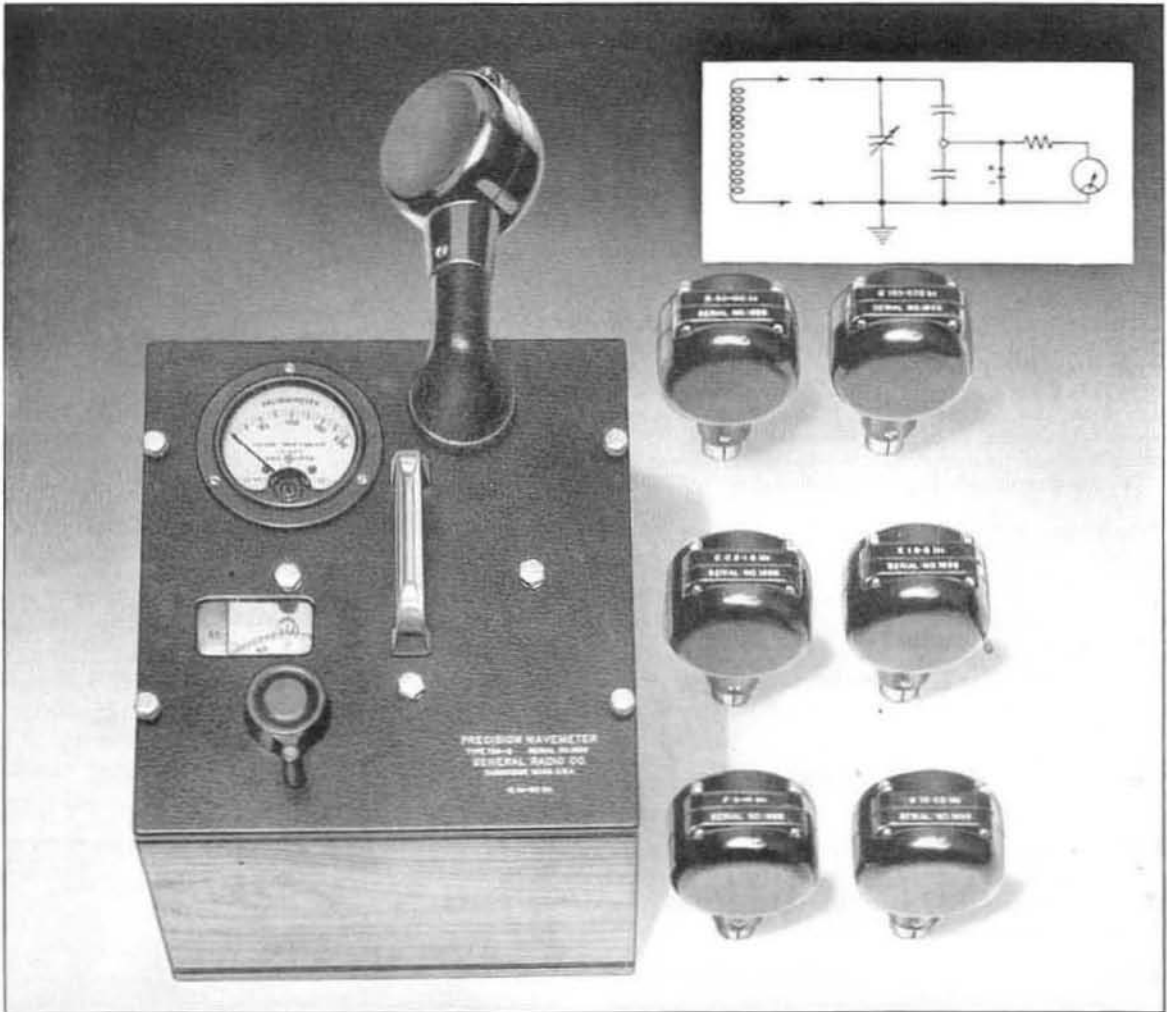

TYPE 724-B PRECISION WAVEMETER

USES: The precision wavemeter fills a definite need in the field of frequency measurement. Its accuracy is sufficient for many measurements which require a fairly close knowledge of the frequency, but where more precise heterodyne methods are neither necessary nor convenient. Among these applications is the preliminary lining up of radio transmitters and checking the frequency span of oscillators.

DESCRIPTION: The TYPE 724-B Precision Wavemeter is a tuned-circuit instrument, consisting of a precision capacitor, a resonance indicator, and a set of inductors. The capacitor is similar in constructional details to TYPE 722. (See page 44.)

FEATURES: ▶ No cumbersome calibration curves are needed because of the straight-line-frequency capacitor. The calibration data are in tabular form, and specific frequencies are found by interpolating between the points in the table.

▶ All inductors have been designed to have very low losses and a high degree of stability.

▶ The plug-in coil mounting allows the coil to be rotated to obtain different degrees of coupling. This feature is a considerable convenience in operation, making it unnecessary to hold the wavemeter in awkward positions to couple it to oscillator tuned circuits.

▶ A germanium crystal rectifier is used as the resonance indicator with a microammeter.

SPECIFICATIONS

Frequency Range: 16 kilocycles to 50 megacycles.

Accuracy: $\pm 0.25\%$.

Calibration: The calibration is supplied in the form of a table of calibrated points. Linear interpolation between these points is used to obtain settings for other frequencies.

Capacitor: Precision worm-drive type similar to TYPE 722. The capacitor setting is indicated on the dial and drum and is controlled from the front of the panel. There are 7500 divisions for the entire 270-degree angular rotation of the capacitor rotor. The precision of setting is better than one part in 25,000. The plates are shaped to give an approximately linear variation in frequency with scale setting.

Inductors: Coils are wound on steatite forms and enclosed in molded phenolic cases. Seven coils are used to cover a frequency range between 16 kilocycles and 50 megacycles.

Resonance Indicator: A germanium crystal rectifier is used with a microammeter to indicate resonance. The indicator is coupled to the tuned circuit through a capacitive voltage divider.

Crystal: A 1N34 germanium crystal rectifier is used.

Mounting: A wooden storage case, fitted with lock and carrying handle, is furnished. This has compartments for holding the capacitor, inductors, and calibration charts.

Dimensions: Carrying case, 17 $\frac{3}{4}$ x 13 x 12 $\frac{1}{2}$ inches, over-all.

Net Weight: With carrying case, 34 pounds; without carrying case, 18 pounds.

| Type | | Code Word | Price |
|-------|--------------------------|-----------|----------|
| 724-B | Precision Wavemeter..... | WOMAN | \$275.00 |

TYPE 758-A WAVEMETER

USES: In the very-high-frequency range, 55 to 400 Mc, this wavemeter provides a convenient and accurate means of measuring the frequencies of oscillators.

DESCRIPTION: TYPE 758-A Wavemeter is a tuned-circuit absorption type of instrument, in which the capacitance and inductance are varied simultaneously. This permits a wide range of frequency to be covered with a single coil. The coil is connected permanently into the circuit. The resonance indicator is an incandescent lamp.

FEATURES: ▶ A wide frequency range is covered without the bother of changing coils.

▶ A transparent material is used to enclose the circuit elements so that they can be seen at all times. This feature is of help in coupling the wavemeter to a circuit.

▶ The indicator lamp will glow when measuring the frequency of an oscillator with about two watts output. For low-power oscillators the reaction on the plate or grid current can be used to indicate resonance.

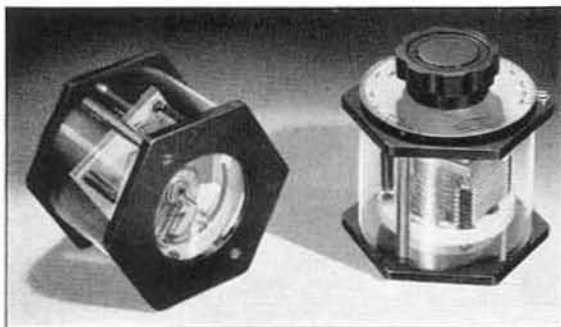
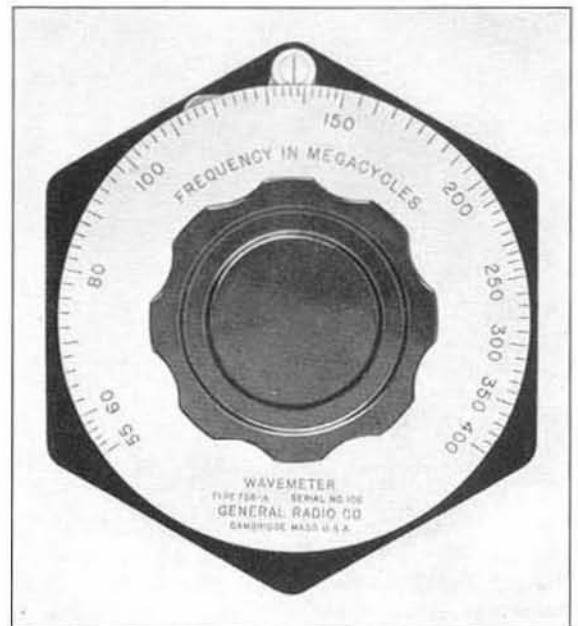

SPECIFICATIONS

Range: 55 Mc to 400 Mc, direct reading.

Accuracy: ±2%.

Temperature and Humidity: The accuracy of this wavemeter is completely independent of temperature and humidity effects over the ranges normally encountered.

Resonance Indicator: Incandescent lamp.

Accessories Supplied: One spare indicator lamp.

Dimensions: 5 x 5 x 4 $\frac{3}{4}$ inches, over-all.

Net Weight: 1 $\frac{3}{4}$ pounds.

| Type | | Code Word | Price |
|-------|----------------|-----------|---------|
| 758-A | Wavemeter..... | WITTY | \$35.00 |

FREQUENCY

TYPE 1140-A U-H-F WAVEMETER



USES: This instrument fills the need for a frequency measuring instrument of moderate accuracy in the ultra-high frequency range. It will measure to $\pm 2\%$ the frequency of oscillators and other sources between 250 and 1200 megacycles.

DESCRIPTION: The frequency-determining element in the TYPE 1140-A Wavemeter is a butterfly circuit in which capacitance and inductance are varied simultaneously by a single control. The resonance-indicating circuit consists of a crystal detector and a microammeter. These elements, together with the direct-reading drum-type frequency scale and a slow-motion drive, are mounted in a convenient molded phenolic case.

- FEATURES:**
- ▶ Low losses and permanence of calibration are assured by the butterfly circuit, which requires no moving contacts.
 - ▶ A wide frequency range is covered by a single rotation of the dial.
 - ▶ The small detector cartridge is easily replaced, if burned out or damaged, without affecting the calibration.
 - ▶ Sensitivity is sufficient to give a meter reading with oscillators having only 20 milliwatts output.

(Left) View of wavemeter showing tuning control and resonance indicator. A window is provided at the rear through which the butterfly circuit is visible.

SPECIFICATIONS

Range: 250 to 1200 Mc.

Accuracy: $\pm 2\%$.

Temperature and Humidity: The accuracy of this wavemeter is independent of temperature and humidity effects over the range of room temperatures and humidities normally encountered in the laboratory.

Detector: The detector is mounted in a standard cartridge and can be replaced if damaged by overloading. A 1N22 Silicon crystal detector is used.

Dimensions: 4 x 4 $\frac{1}{2}$ x 7 $\frac{1}{4}$ inches, over-all.

Net Weight: 3 $\frac{1}{4}$ pounds.

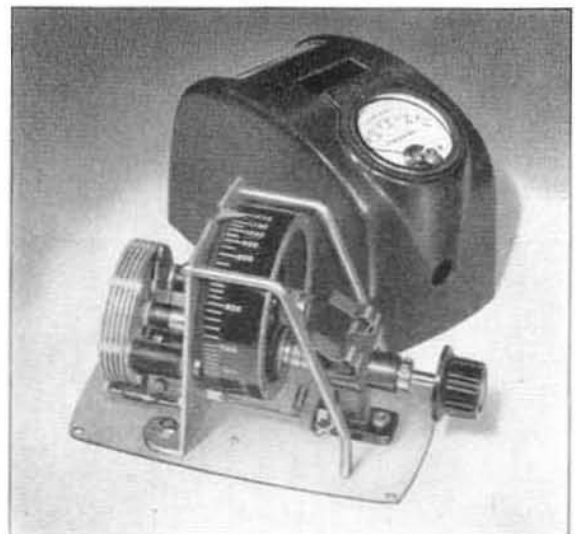

(Right) View with case removed. The two clips shown above the shaft bearing make contact with the meter terminals when the case is on.

| Type | Code Word | Price |
|-----------------------|-----------|---------|
| 1140-A Wavemeter..... | WAGER | \$70.00 |

PATENT NOTICE. See Note 10, page vi.

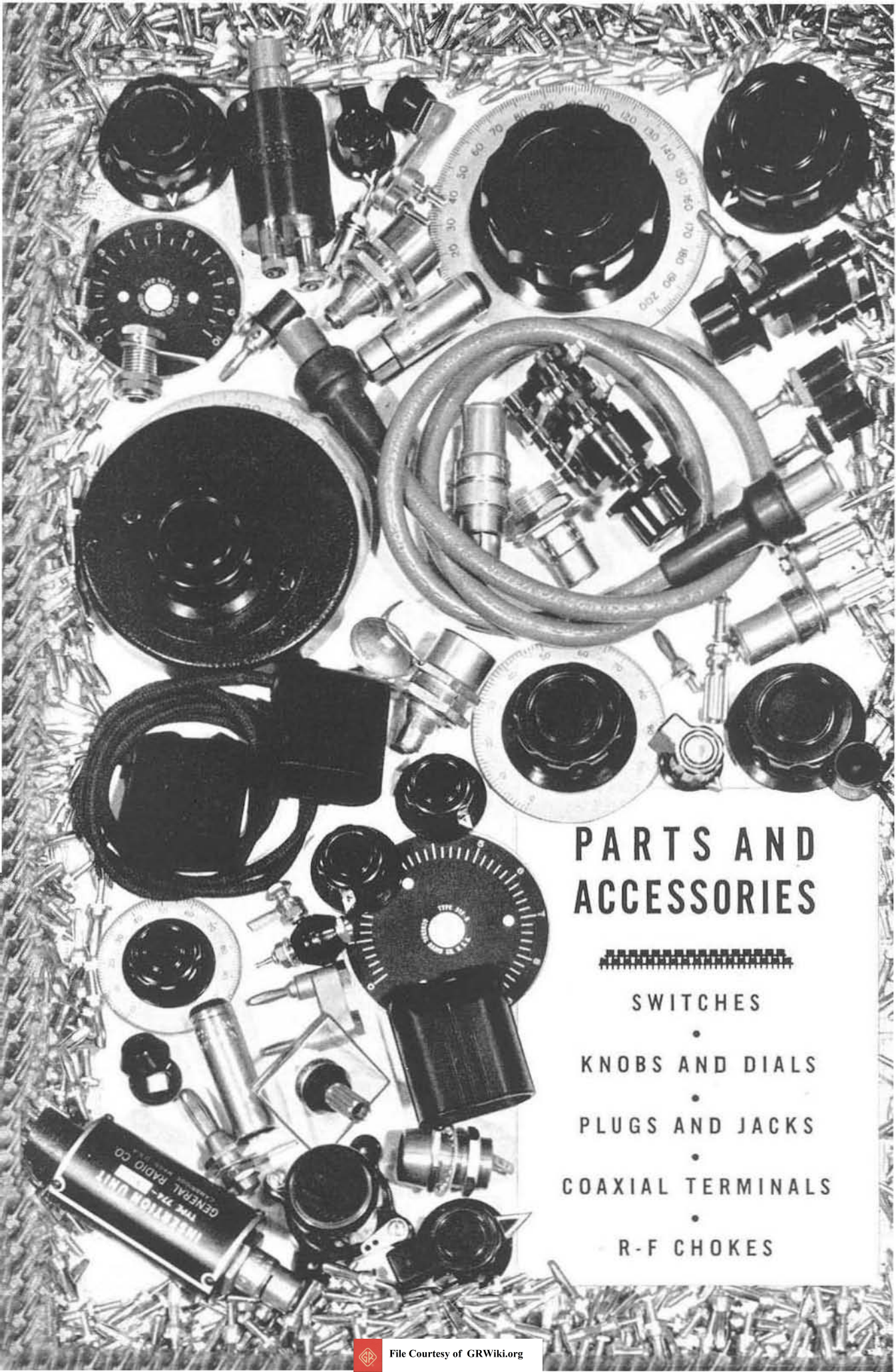

PARTS AND ACCESSORIES



SWITCHES

•
KNOBS AND DIALS

•
PLUGS AND JACKS

•
COAXIAL TERMINALS

•
R-F CHOKES



PARTS AND ACCESSORIES

TYPE 907 GEAR-DRIVE PRECISION DIALS



(Left) TYPE 907-LA Gear-Drive Precision Dial, front-of-panel model, and (right) TYPE 907-LB Gear-Drive Precision Dial designed for back-of-panel mounting.

The TYPE 907 Gear-Drive Precision Dials have 4-inch diameter frosted chrome scales individually engraved on an automatic self-indexing engraving machine. The fine, radial, accurately located lines divide the complete circumference into 360 divisions numbered from 0 to 360.

Settings of these dials can consistently be duplicated to one-fifth of a division, allowing a precision of resetting of better than 0.06% of full scale. Parallax is eliminated by the use of an indicator that always remains flush with the surface of the dial, and which at the same time absorbs, through the flexibility of its mounting arm, any slight eccentricities of the main shaft.

The ring gear and drive pinion are precision cut gears, spring pressed to eliminate any backlash. The drive ratio is 10:1, and it is possible to use a calibrated vernier or incre-

ment dial on the pinion shaft if desired. Any standard TYPE 901 dial (page 201) can be adapted for use on the pinion shaft. The drive pinion is held in a stainless steel collet which runs in a phosphor-bronze bushing. The collet allows the drive to be adjusted for any panel thickness up to $\frac{3}{16}$ inch.

The main dials are set permanently and securely to their shafts through the use of two set-screws 90° apart; this procedure eliminates any dial backlash which might otherwise occur. The dial hubs are bored to receive a $\frac{3}{8}$ -inch shaft, but a split bushing is provided for use with $\frac{1}{4}$ -inch shafts. The 360-division dial plate is held by three screws, and can be easily replaced with other 4-inch dial plates such as the TYPE 904 (page 201).

The dial indicator, knob, and all necessary mounting parts are supplied, as are complete drilling and mounting instructions.

► 4-INCH DIAMETER GEAR-DRIVE PRECISION DIALS

| Type | Mounting | Dial | | Gear-Drive Ratio | Net Weight | Code Word | Price |
|--------|----------------|------|-----------|------------------|------------|-----------|--------|
| | | Arc | Divisions | | | | |
| 907-LA | Front-of-panel | 360° | 360 | 10:1 | 11 oz. | DITAB | \$9.50 |
| 907-LB | Back-of-panel | 360° | 360 | 10:1 | 11 oz. | DITOP | 9.50 |

PATENT NOTICE. See Note 17, page vi.



TYPE 520-A DIAL LOCK

Any General Radio direct- or friction-drive dial can be firmly clamped in any position by means of the TYPE 520-A Dial Lock. This lock holds the edge of the dial in a vise-like grip without exerting appreciable force on the shaft on which the dial is mounted. The lock does not alter the dial setting and can be unclamped by loosening the knurled knob when it is desired to change the dial to a new setting.

Dimensions: (Length) 2 x (width) 1 x (height) 1½ inches, over-all. Height above panel, 1 inch.

Mounting: Two No. 28 holes, ¾ inch apart, are required for mounting.

Net Weight: 1½ ounces.

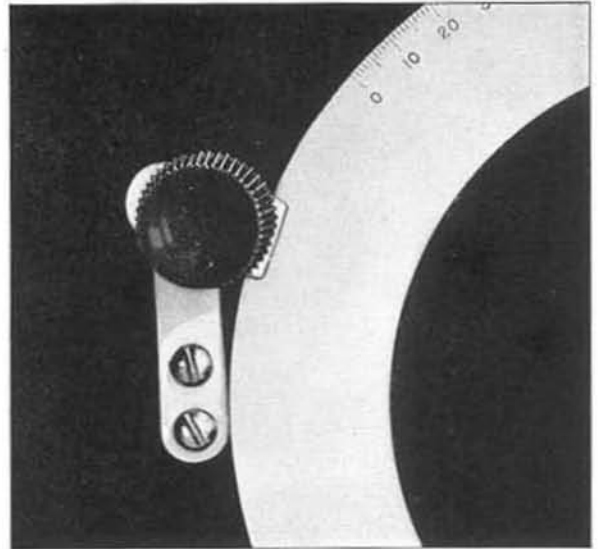

View of TYPE 520-A Dial Lock installed on a precision dial.

| Type | Code Word | Price |
|-------|-----------|--------|
| 520-A | ABATE | \$0.75 |

TYPE 318-B AND TYPE 522-A DIAL PLATES

These dial plates are designed for use with the Rheostats and Voltage Dividers described on pages 38 to 40. Each dial plate is attached to the panel with the same mounting screws that hold the rheostat with which it is used. These screws and the necessary knob are furnished with the rheostat and are not supplied with the dial plates.

The TYPE 318-B Dial Plate is a 3-inch diameter plate marked with 50 divisions

around 298°. It is drilled for standard 3-hole mounting and is suitable for use with rheostat-voltage dividers such as TYPES 214, 314, 371, and 471.

The TYPE 522-A Dial Plate is a 2½-inch diameter plate marked with 20 divisions around 254°. It is designed for use with the TYPE 301 Rheostat-Voltage Divider and is drilled for mounting with that unit.

| Type | | Net Weight | Code Word | Price |
|-------|------------------|------------|-----------|--------|
| 318-B | Dial Plate | ¾ oz. | DEVIL | \$0.65 |
| 522-A | Dial Plate | ½ oz. | DOGMA | .50 |

TYPE 318-B

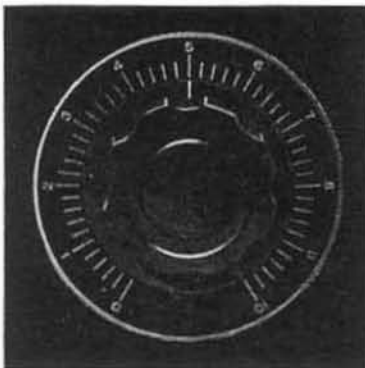

TYPE 522-A



OTHER DIALS

Direct- and friction-drive dials are described and shown on the next two pages.



PARTS AND ACCESSORIES



902-HF



901-LD

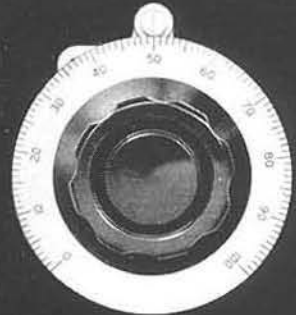

902-JD

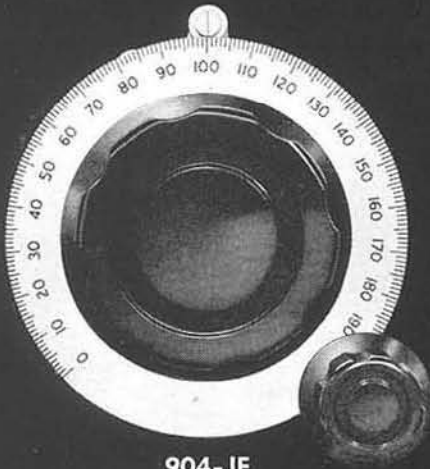

904-JF

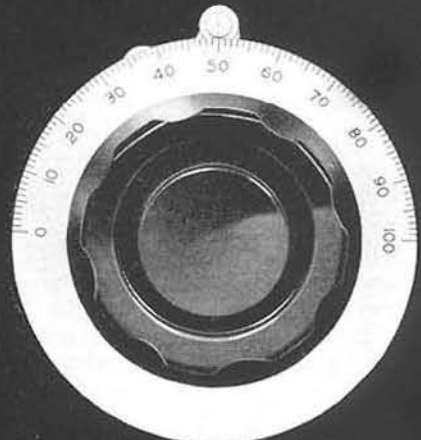

904-HD



905-JF



906-JF

ONE-HALF ACTUAL SIZE



FRICTION-DRIVE AND DIRECT-DRIVE DIALS

Four different dial sizes are available in this series of dials extending from 2 inches to 6 inches in diameter. The TYPES 901, 902, and 904 have scales with photo-etched characters and divisions, and are designed for applications where extreme precision is not required.

Where a precision friction-drive dial is required, the TYPES 905 and 906 are very well suited. The scales for these dials are individually engraved on an automatic engraving machine, which produces fine, accurately located lines. Settings of these dials can be duplicated consistently to one-fifth of a division, allowing a precision of resetting for the TYPE 906-JF Precision Dial of better than 0.05% of full scale.

The precision dials, TYPES 905 and 906, are available only with a friction drive. The dial plates have a horseshoe-shaped slot into which the drive is mounted. The tension of the friction drive is adjustable to suit the load and the preference of the operator, and the position of the friction-drive shaft can be adjusted by means of an eccentric bushing to compensate for any errors in the centering of the main shaft in the center hole.

The smallest dials, TYPE 901, are available only with direct drive, but the TYPES 902 and 904 are available with both direct and friction drives. The friction-drive mechanism used on these dials consists of a thin disc, which is mounted on the back of the dial plate, gripped and driven by two small discs attached to the friction-drive shaft. This drive shaft is mounted in an eccentric bushing so that the tension of the drive can be easily adjusted after the dial and drive are mounted.

All of the dials with the exception of the TYPES 905 and 906 Precision Dials have the dial plates insulated from the shaft. All models are secured to their shafts by the use of two setscrews separated by 90°, and are supplied bored to receive a 3/8-inch shaft. Bushings are provided so that the dials can be easily arranged for mounting on 1/4-inch shafts.

The indicators shown in the photographs are designed to remain flush with the surface of the dial, thus eliminating parallax and absorbing any slight eccentricities of the main shaft. The indicators, necessary mounting screws, drive knobs, and mounting templates are furnished with the dials.

▶ 6-INCH DIAMETER — TYPE 906 PRECISION DIALS

| Type | Dial | | Drive | Net Weight | Code Word | Price |
|--------|------|-----------|---------------|------------|-----------|---------|
| | Arc | Divisions | | | | |
| 906-HF | 180° | 300 | Friction, 8:1 | 15 oz. | DIROT | \$12.00 |
| 906-JF | 270° | 450 | Friction, 8:1 | 15 oz. | DIRAP | 12.00 |

▶ 4-INCH DIAMETER — TYPE 905 PRECISION DIALS

| | | | | | | |
|--------|------|-----|---------------|-------|-------|---------|
| 905-HF | 180° | 200 | Friction, 6:1 | 9 oz. | DIRUG | \$10.00 |
| 905-JF | 270° | 300 | Friction, 6:1 | 9 oz. | DIRIM | 10.00 |

▶ 4-INCH DIAMETER — TYPE 904 DIALS

| | | | | | | |
|--------|------|-----|---------------|-------|-------|--------|
| 904-HD | 180° | 100 | Direct | 5 oz. | DIPAR | \$3.25 |
| 904-JD | 270° | 200 | Direct | 5 oz. | DIPOD | 3.25 |
| 904-HF | 180° | 100 | Friction, 5:1 | 8 oz. | DIPEN | 4.25 |
| 904-JF | 270° | 200 | Friction, 5:1 | 8 oz. | DIPUT | 4.25 |

▶ 2 3/4-INCH DIAMETER — TYPE 902 DIALS

| | | | | | | |
|--------|------|-----|-----------------|-----------|-------|--------|
| 902-HD | 180° | 100 | Direct | 2 1/2 oz. | DIMAP | \$2.75 |
| 902-JD | 270° | 100 | Direct | 2 1/2 oz. | DIMID | 2.75 |
| 902-HF | 180° | 100 | Friction, 3.3:1 | 4 oz. | DIMOB | 3.75 |
| 902-JF | 270° | 100 | Friction, 3.3:1 | 4 oz. | DIMUG | 3.75 |

▶ 2-INCH DIAMETER — TYPE 901 DIALS

| | | | | | | |
|--------|------|-----|--------|-------|--------|--------|
| 901-HD | 180° | 100 | Direct | 2 oz. | DHLOG | \$2.75 |
| 901-JD | 270° | 100 | Direct | 2 oz. | DH LAP | 2.75 |
| 901-LD | 360° | 100 | Direct | 2 oz. | DHLD | 2.75 |

PATENT NOTICE. See Note 17, page vi.



TYPE KN FLUTED KNOBS

These molded phenolic knobs are designed for use on General Radio apparatus. However, they are also made available for sale separately because they are well suited for use on measuring instruments of all kinds. The bar knobs are especially convenient for use on switches, and the TYPE ZKNU-3 Spinner Knob has been designed with an auxiliary finger spinner for use on slow-motion drives.

All of the knobs except the TYPE ZKNU-3 Spinner Knob are molded in one piece with a brass insert bored for a $\frac{3}{8}$ -inch shaft. Bushings are furnished with all models to allow their use on $\frac{1}{4}$ -inch shafts. Two set-screws spaced 90° apart are provided on all of the knobs.

All models except the TYPES ZKNU-3 Spinner Knob and KNS-12 Fluted Knob have molded, filled, white pointers. The diameters given below are the diameters of the skirts.

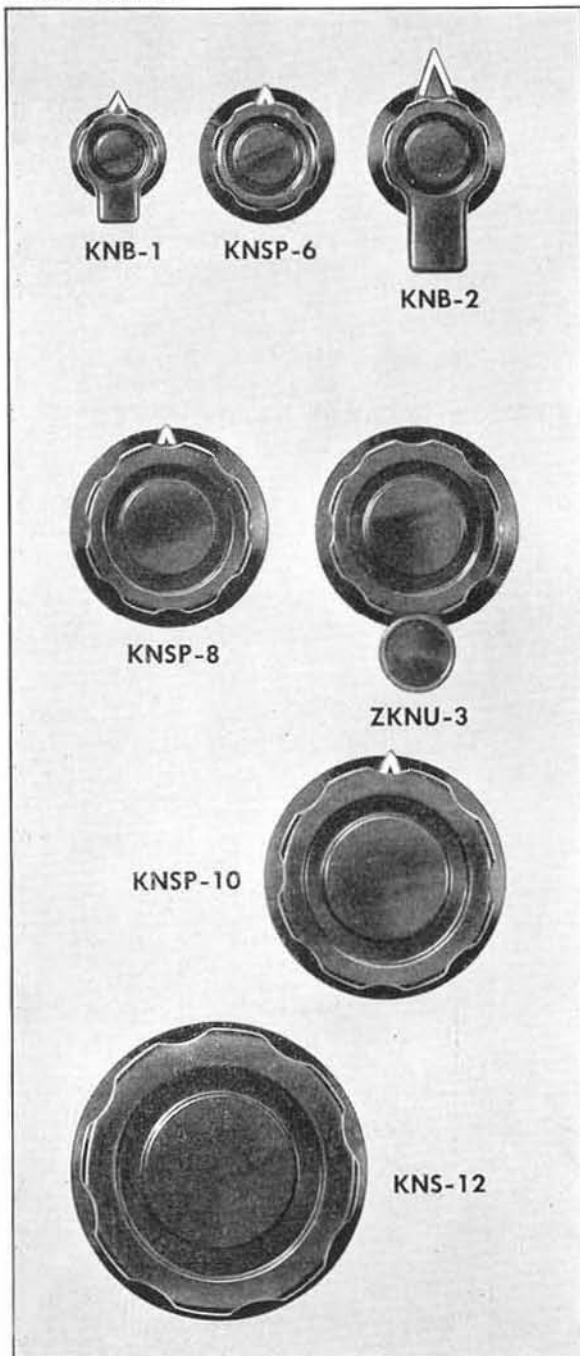

► **1-INCH DIAMETER — WITH BAR**

| Type | Net Weight for 5 | Code Word | Package of 5 | Package of 20 |
|-------|---------------------|------------|-----------------|------------------|
| KNB-1 | 3¾ oz. . . . | BARKNOBONE | \$3.50 | \$13.00 |

► **1 3/8-INCH DIAMETER — WITH BAR**

| Type | Net Weight for 5 | Code Word | Package of 5 | Package of 20 |
|-------|---------------------|------------|-----------------|------------------|
| KNB-2 | 6 oz. | BARKNOBTWO | \$3.75 | \$14.00 |

► **1 3/8-INCH DIAMETER**

| Type | Net Weight for 5 | Code Word | Package of 5 | Package of 20 |
|--------|---------------------|------------|-----------------|------------------|
| KNSP-6 | 5½ oz. | NURLNOBSIX | \$3.00 | \$11.00 |

► **2-INCH DIAMETER**

| Type | Net Weight for 5 | Code Word | Package of 5 | Package of 20 |
|--------|---------------------|------------|-----------------|------------------|
| KNSP-8 | 8 oz. | NURLNOBATE | \$4.25 | \$16.00 |

► **2-INCH DIAMETER — WITH SPINNER**

| Type | Net Weight | Code Word | Unit Price |
|--------|----------------|------------|------------|
| ZKNU-3 | 2¾ oz. | SPINNOBTRE | \$3.00 |

► **2 3/8-INCH DIAMETER**

| Type | Net Weight for 5 | Code Word | Package of 5 | Package of 20 |
|---------|---------------------|------------|-----------------|------------------|
| KNSP-10 | 12½ oz. . . . | NURLNOBTEN | \$5.50 | \$21.00 |

► **2 7/8-INCH DIAMETER — WITHOUT POINTER**

| Type | Net Weight for 5 | Code Word | Package of 5 | Package of 20 |
|--------|---------------------|------------|-----------------|------------------|
| KNS-12 | 17 oz. | NURLNOBDOZ | \$5.75 | \$22.00 |

PATENT NOTICE. See Note 17, page vi.

THE QUANTITY DISCOUNTS MENTIONED ON PAGE IV ALSO APPLY TO QUANTITIES OF PACKAGES.

The TYPE KN Fluted Knobs are shown approximately one-half actual size in the photograph.



TYPE 874 COAXIAL CONNECTORS

The new TYPE 874 Coaxial Connector is designed for the high-frequency laboratory where good electrical performance and convenience in use are equally important. The characteristic impedance of the connector is 50 ohms. If used with cables and other coaxial elements of proper design, reflections at the connector junction are small at all frequencies up to 3000 megacycles.

Only one universal basic connector is required for all purposes. Two of these connectors plug smoothly into each other without any intermediate elements, and the

complication of male and female ends is completely eliminated. For added convenience the inner connector is designed to receive a TYPE 274 Plug. A double-shielded low-loss 50-ohm cable, and several connectors, are available at present, and other coaxial elements will be announced later.

All metal parts are finished in Bright-Alloy plate. The insulating bead is polystyrene, and is molded with keyways for positive alignment of the inner and outer conductors.

SPECIFICATIONS

Type 874-B Basic Connector consists of inner and outer conductors, insulating bead, coupling nut, and retaining ring. This connector is designed for attachment to rigid, 50-ohm, air-dielectric, coaxial line made from $\frac{5}{8}$ " OD, $\frac{3}{16}$ " ID tubing and 0.244" D rod. The inner conductor is to be screwed into an 8-32 tapping in the end of the rod, and the retaining ring for the coupling nut is to be snapped into a $\frac{1}{64}$ " deep, 0.035"-wide groove cut in the $\frac{5}{8}$ " tubing.

Type 874-C Cable Connector contains the Basic Connector parts plus inner and outer transition pieces, a soft copper ferrule, and a rubber guard. The transition pieces are designed to attach to TYPE 874-A2 Polyethylene Cable and are tapered so as to maintain the 50-ohm characteristic impedance of the connector and cable throughout the change in diameters. The cable inner conductor is to be soldered to the inner transition piece, and the cable braid is attached to the outer transition piece by crimping the ferrule. The rubber guard provides a protective handle.

Type 874-P Panel Connector is similar to the Cable Connector, including transition pieces for TYPE 874-A2 Cable, except that a panel adaptor and nut are supplied in place of the rubber guard. The panel adaptor fits into a $\frac{15}{16}$ " D hole in panels from $\frac{1}{16}$ " to $\frac{1}{4}$ " thick and is designed to clamp the connector in any desired orientation.

Type 874-PC Panel Connector with Cap is similar to the TYPE 874-P except that the panel adaptor is equipped with a captive, hinged, spring cap that effectively shields the open connector when not in use.

Type 874-Q2 Adapter is designed for making the output of a coaxial system available at a pair of $\frac{3}{4}$ -inch spaced binding posts or plugs.

Type 874-Q7 Adapter is used to connect from a TYPE 874 Coaxial Connector to any TYPE 774 Coaxial Connector.

Type 874-A2 Polyethylene Cable consists of a No. 14 stranded inner conductor, separated from a double-braid tinned-copper shield by 0.244" OD Polyethylene N1 insulation, and with an outer gray Plastex jacket 0.365" OD. The characteristic impedance is 50 ohms $\pm 5\%$, and the nominal capacitance is 32 μf per foot. The attenuation at 100 Mc is about 2.6 db per 100 feet, and at 1000 Mc about 10.5 db per 100 feet.

Type 874-R20 Patch Cord consists of three feet of TYPE 874-A2 Polyethylene Cable with a TYPE 874-C on each end.

| Type | Net Weight | Code Word | Price |
|---------|-------------------------|------------|---------|
| 874-B | $\frac{3}{8}$ oz. | COAXBRIDGE | \$1.50 |
| 874-C | 1 $\frac{1}{4}$ oz. | COAXCABLER | 2.00 |
| 874-P | 2 $\frac{1}{4}$ oz. | COAXPEPPER | 2.25 |
| 874-PC | 2 $\frac{1}{4}$ oz. | COAXCAPPER | 2.75 |
| 874-Q2 | 2 $\frac{1}{4}$ oz. | COAXTIPPER | 3.00 |
| 874-Q7 | 2 $\frac{1}{4}$ oz. | COAXPASSER | 3.75 |
| 874-A2 | 1 $\frac{1}{2}$ oz./ft. | COAXCUTTER | 0.50/ft |
| 874-R20 | 7 oz. | COAXHATTER | 6.25 |

PATENT NOTICE. See Note 31, page vi.

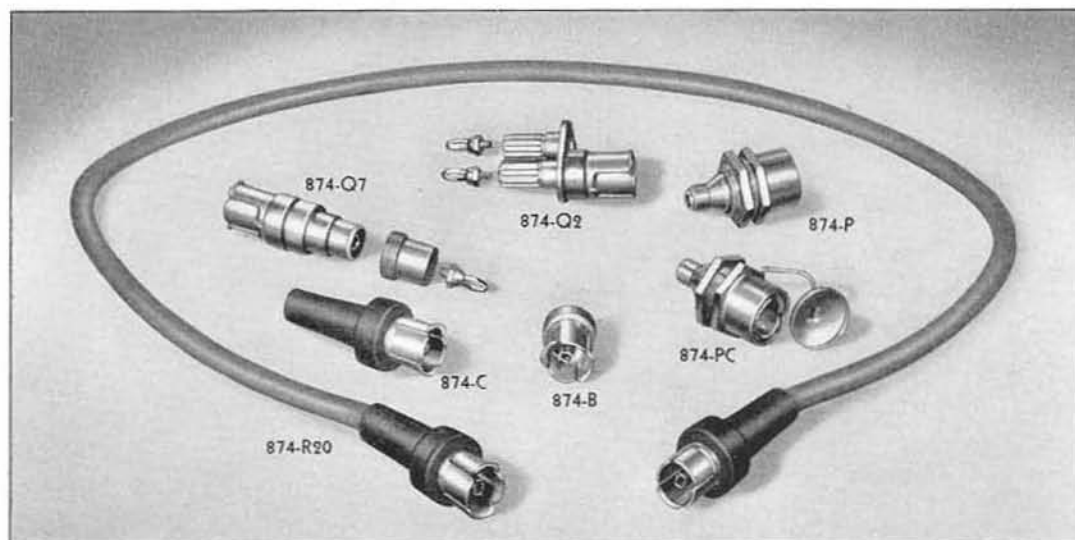

PARTS AND ACCESSORIES

TYPE 774 COAXIAL TERMINALS

At high and ultra-high frequencies, the interconnection of the various elements in a measuring system is best accomplished by means of coaxial lines. TYPE 774 Coaxial Terminals are concentric plug-and-jack units intended for use with coaxial lines. They are used in a number of General Radio instruments, among them the TYPE 821-A Twin-T, the TYPE 916-A Radio-Frequency Bridge, and the TYPE 805-C Standard-Signal Generator.

In order to reduce impedance mismatch with any line having a different characteristic impedance, TYPE 774 Coaxial Terminals have been made with short internal conductors

and with low capacitance. In order to provide as continuous an external shield as possible, lugs have been provided for four connections to the outer shell from the cable sheath at points uniformly distributed around the circumference.

The solid dielectric is polystyrene, which has both a low dielectric constant and a low dissipation factor.

A plug unit and a jack unit are available for mounting on panels, and a similar pair of units for terminating coaxial cables. The plug connector and the jack connector make it possible to join two cables having identical terminations, that is, two plugs or two jacks.

SPECIFICATIONS

Capacitance: For many applications the capacitance of these units is the factor to be considered in determining their suitability. The capacitance for each TYPE 774 Unit is given in the description on the next page. In addition to the total capacitance there is given, for many units, a figure called "insertion capacitance," which is the capacitance added to a circuit when that particular unit is plugged in. This is lower than the total capacitance because of the overlapping when a plug unit is plugged into a jack.

Materials: Metallic parts are of nickel-plated brass; insulation is polystyrene.

Cable: The cable consists of a standard beryllium-copper conductor, separated from a braided tinned-copper shield by Anhydrex A insulation, with an over-all covering of abrasion-resistant rubber. The nominal characteristic impedance is 72 ohms $\pm 10\%$; the nominal capacitance is 26 μf per foot; and the dissipation factor is 0.02 or less at 1000 cycles.

Dimensions: All drawings are approximately $\frac{1}{2}$ scale. **Net Weight:** See descriptions on next page.

PATCH CORDS

The TYPE 774-R Patch Cords consist of a 3-foot section of concentric-shielded cable (see specifications above) terminated in TYPE 774 Coaxial Cable Terminals.

The TYPE 774-R1 has a TYPE 774-M Cable Jack at one end and a TYPE 774-E Cable Plug at the other. The TYPE 774-R2 has a TYPE 774-M Cable Jack at each end.

| Type | | Net Weight | Code Word | Price |
|--------|------------|------------|------------|--------|
| 774-R1 | Patch Cord | 5 oz. | ACCESSORIM | \$5.50 |
| 774-R2 | Patch Cord | 5 oz. | ACCESSORAT | \$5.50 |

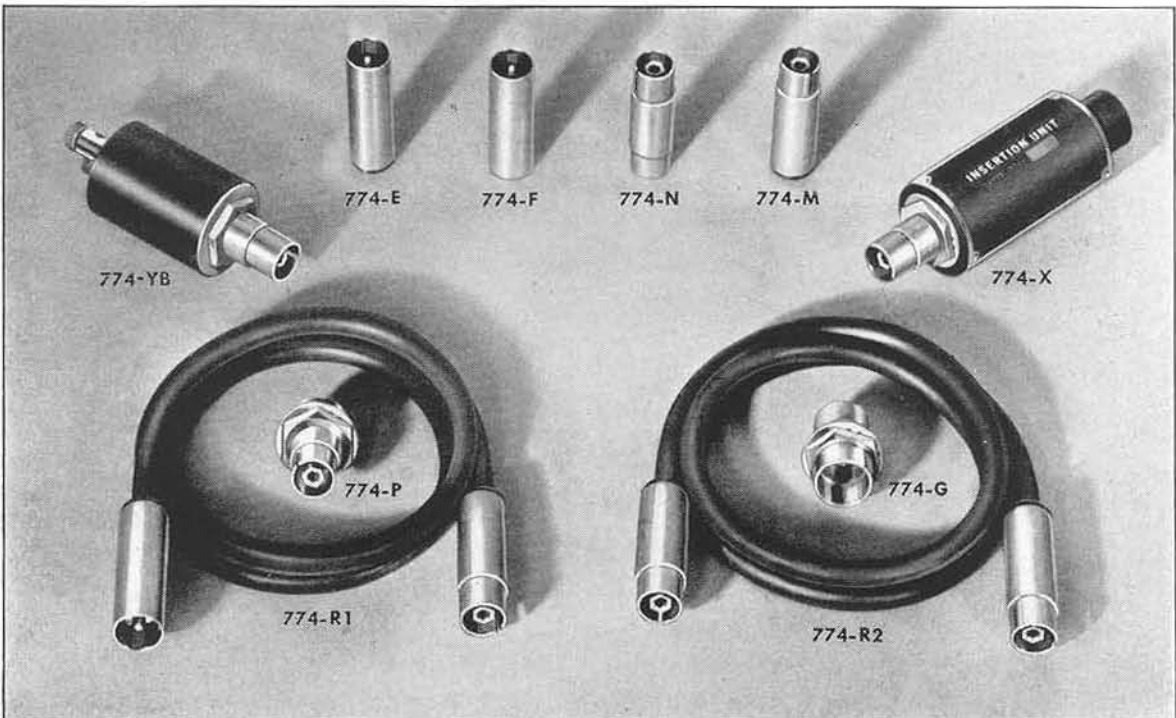

TYPE 774-E CABLE PLUG

This is a plug connector unit for use with concentric shielded cables ($\frac{3}{16}$ inch or less in diameter). The connection of the inner conductor is made by means of a TYPE 274 Plug, while the outer sleeve fits snugly around the split sleeves of the jack terminals or connectors. Four soldering lugs are provided for connecting to the shield of a concentric cable, as is a lug for the inner conductor.

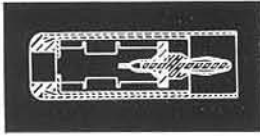

Total Capacitance: 2.5 μ f.
 Insertion Capacitance: 1.4 μ f.
 Net Weight: 1 $\frac{1}{2}$ oz.
 Code Word: ACCESSOEYE
 Price: \$1.75

TYPE 774-P PANEL JACK

A metal stud, supported by a polystyrene strip, is mounted concentrically with the outer shell, and is recessed to receive the TYPE 274 Plug of the plug connector units. The outer conductor is a split sleeve which grounds to the panel on which the jack is mounted. In conjunction with the sleeve of a cable plug or connector unit it very effectively shields the high lead connection.

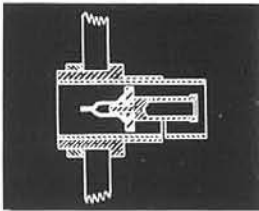

Total Capacitance: 2.8 μ f.
 Insertion Capacitance: 1.7 μ f.
 Net Weight: 1 $\frac{3}{4}$ oz.
 Code Word: ACCESSOPOD
 Price: \$2.00

TYPE 774-M CABLE JACK

This is the jack unit for connecting a concentric cable to a TYPE 774-G Panel Plug. Similar in construction to the cable plug, a recessed stud takes the TYPE 274 Plug, while a split sleeve fits into the outer sleeve of the plug terminals.

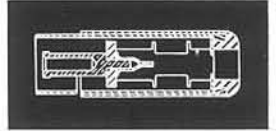

Total Capacitance: 2.8 μ f.
 Insertion Capacitance: 1.7 μ f.
 Net Weight: 1 $\frac{1}{2}$ oz.
 Code Word: ACCESSOMUD
 Price: \$1.75

TYPE 774-G PANEL PLUG

This unit consists of a TYPE 274 Plug mounted axially in the center of a brass shell. The plug is supported on a polystyrene insulating strip which serves to isolate it from the outer conductor. The assembly requires a $\frac{3}{4}$ -inch mounting hole and may be mounted on any panel thickness up to $\frac{1}{2}$ inch. The entire plug assembly is nickel plated. A tinned soldering terminal is provided for the central plug, while the outer conductor grounds to the metal panel.

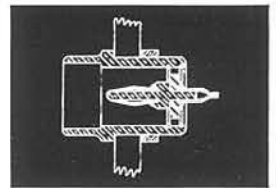

Total Capacitance: 2.4 μ f.
 Insertion Capacitance: 1.3 μ f.
 Net Weight: 1 $\frac{3}{4}$ oz.
 Code Word: ACCESSOGOD
 Price: \$1.75

CONCENTRIC CONNECTORS

To obtain maximum flexibility with the cable and panel terminals described above, it is desirable to have adapters available to connect between two terminals of the same kind. The TYPE 774-F Plug Connector and TYPE 774-N Jack Connector are two-way units designed for this purpose.

The plug connector has a plug terminal at either end and may thus be used to connect a jack-terminated cable to a panel jack, or to connect two cable jacks together. In a similar manner the jack connector makes possible connection of two plug-type terminals.

TYPE 774-N JACK CONNECTOR

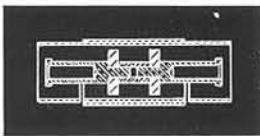

Total Capacitance: 4.2 μ f.
 Insertion Capacitance: 2.0 μ f.
 Net Weight: 1 oz.
 Code Word: ACCESSONUT
 Price: \$2.00

TYPE 774-F PLUG CONNECTOR



Total Capacitance: 3.6 μ f.
 Insertion Capacitance: 1.3 μ f.
 Net Weight: 1 oz.
 Code Word: ACCESSOFIG
 Price: \$2.00

TYPE 774-X INSERTION UNIT

This unit is designed for housing dummy antennas, impedance-matching networks, attenuators, and similar circuits. It consists essentially of a hollow cylindrical aluminum casting with a plug connector at one end and a jack connector at the other. One side is partially cut away to permit the connection of circuit elements between the two terminals. A nickel-silver nameplate covers this opening, completing the shielding of the high potential terminals.

Total Capacitance: 6.0 μ f.
 Insertion Capacitance: 4.9 μ f.

| Type | Net Weight | Code Word | Price |
|-------|---------------------|------------|--------|
| 774-X | 4 $\frac{1}{2}$ oz. | ACCESSOXEB | \$7.50 |

TYPE 774-YB TERMINAL UNIT

This unit provides a shielded housing for terminating resistors, at the same time making the output of a coaxial system available at a pair of $\frac{3}{4}$ -inch spaced binding posts. As shown in the accompanying sketch, it consists of a coaxial jack, a pair of binding posts, and a metal housing.

Total Capacitance: 5.1 μ f.
 Insertion Capacitance: 4.0 μ f.

| Type | Net Weight | Code Word | Price |
|--------|------------|------------|--------|
| 774-YB | 4 oz. | ACCESSOYAM | \$6.00 |

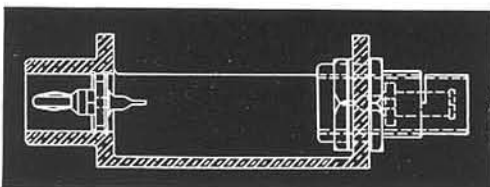

ALL
 DRAWINGS
 ARE $\frac{1}{2}$ SIZE

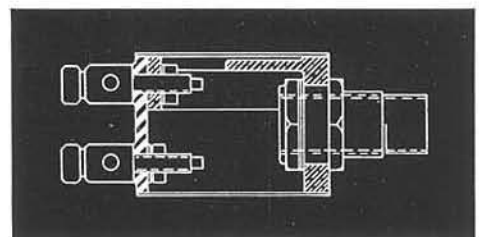

TYPE 938 STANDARD PARTS

The TYPE 938 Standard Parts have been designed primarily for use in General Radio equipment. Below are listed several of the most useful items, which are being made available to manufacturers and experimenters for use in the assembly of laboratory and experimental equipment.

Type 938-A Binding Post

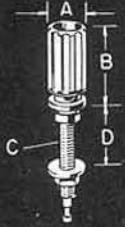

938-A

- A = 3/8 inch
- B = 23/32 inch min.
- C = 6-32
- D = Panel = 15/16 inch max.

Code Word: STANPARASP
 Package of 10 \$3.20
 Package of 100 28.00

Type 938-B Insulators



938-B

- A = 3/4 inch
- B = 5/16 inch
- C = 1/4 inch square

Code Word: STANPARAUK
 Package of 10 Sets . . . \$1.00
 Package of 100 Sets . . . 8.50

Type 938-J Jack

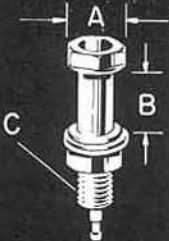

938-J

- A = 3/8 inch hex.
- B = Panel = 3/8 inch max.
- C = 1/4 - 28

Code Word: STANPARACT
 Package of 10 \$1.75
 Package of 100 15.00

Type 938-W Binding Post Assembly

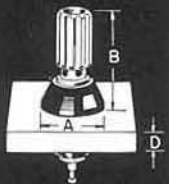

938-W

- A = 3/4 inch
- B = 1 inch min.
- D = Panel = 5/16 inch max.

Code Word: STANPARANT
 Package of 10 \$4.20
 Package of 100 36.50

Type 938-X Jack Assembly

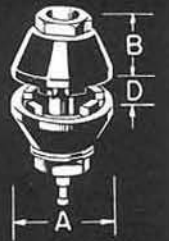

938-X

- A = 3/4 inch
- B = 7/16 inch
- D = Panel = 5/16 inch max.

Code Word: STANPARART
 Package of 10 \$2.75
 Package of 100 23.50

BINDING POST

The TYPE 938-A Binding Post is made of Bright-Alloy-plated brass. Connection can be made to this post in a number of different ways. The bottom of the base is cross-drilled to take phone tips or wire ends directly, while the top is drilled axially to receive the TYPE 274 Plugs. Spade terminals can be secured firmly between the base and fluted nut.

INSULATORS

The TYPE 938-B Insulators are hollow conical insulators molded of black polystyrene. They have been designed specifically for use with the TYPE 938-A Binding Post and the TYPE 938-J Jack (see "Assemblies" below), and the interlocking design allows their use on panels of any thickness.

JACK

The TYPE 938-J Jack is similar to the TYPE 274-J Jack, but is made with a longer shank so that it can be used with the TYPE 938-B Insulators (see TYPE 938-X Jack Assembly below). This jack can also be used without the insulators if it is mounted on a thick panel, or mounted with spacers.

ASSEMBLIES

The TYPE 938-W Binding Post Assembly and the TYPE 938-X Jack Assembly are convenient, bushing-type, jack-top terminals designed for mounting on any panel up to 5/16 inch thick. Both assemblies use the TYPE 938-B Insulators to provide low-loss insulation and a low terminal capacitance. The TYPE 938-W uses the TYPE 938-A Binding Post so that connections to it can be made in several different ways, while the TYPE 938-X uses the TYPE 938-J Jack to which connection can be made by any TYPE 274 Plug. A set of two of either assembly can be mounted with 3/4 inch spacing to take the TYPE 274-M Double Plug. A square shoulder on the binding post keys to the insulator which in turn can be keyed to the panel.

The d-c leakage resistance of the polystyrene insulators is greater than 10 megamegohms, and the dissipation factor less than 0.0005. The direct capacitance between two TYPE 938-W Binding Post Assemblies mounted 3/4 inch apart on a 1/4-inch metal panel is about 0.7 μμf. The capacitance of one post to the panel is about 2.2 μμf. Although not primarily intended for high voltage use, these binding posts can be used safely at voltages up to 4000 volts peak.



TYPE 274 PLUGS AND JACKS

The TYPE 274 parts have become almost indispensable in laboratories everywhere as a simple and flexible means of interconnecting equipment in temporary or semi-permanent setups. In addition to being used on General Radio instruments, they are used by many other manufacturers of laboratory equipment.

JACKS

The basic jack unit is the TYPE 274-J which is made of nickel-plated brass. All TYPE 274-J Jacks are furnished with tinned terminals and nuts. TYPES 274-U and 274-D Plugs and all double plugs are recessed in the top, thus making jacks for other plugs.

SINGLE PLUGS

The TYPE 274-P, the basic unit, consists of a threaded nickel-plated brass stud which is fitted with a beryllium-copper spring. A nut and terminal are furnished. TYPE 274-X is similar to TYPE 274-P, except the stud is not threaded but has a tubular rivet top. TYPE 274-U has a larger threaded stud which is recessed to take a TYPE 274 Plug. TYPE 274-D is similar to TYPE 274-U but has an insulating phenolic sleeve and a thumbscrew.

All plugs will carry a maximum current of 15 amperes on a resistive load.

TYPE 274 Plugs and Jacks are shipped un-assembled.

DOUBLE PLUG

The TYPE 274-M Double Plug consists of two plugs set $\frac{3}{4}$ inch between centers in a molded polystyrene form. The top is recessed, forming a double jack, so that these units can be stacked in parallel. The plugs are drilled to take cord tips, or wire leads, lock nuts being provided for fastening.

The use of polystyrene as the molding material insures high leakage resistance and low dielectric losses. The capacitance between pins is about $0.8 \mu\mu\text{f}$ at a dissipation factor of less than 0.001. The direct-current leakage resistance is greater than 10^8 megohms.

SHORT-CIRCUIT PLUG

The TYPE 274-SB Short-Circuit Plug consists of two TYPE 274-U Plugs and a nickel-plated brass bar.

THE QUANTITY DISCOUNTS MENTIONED ON PAGE IV ALSO APPLY TO QUANTITIES OF PACKAGES.

Type 274-P Plug

A = Panel = $\frac{1}{4}$ inch max.
B = $\frac{1}{16}$ inch C = 6-32
D = $\frac{3}{32}$ inch

Code Word: STANPARCAT

Package of 10 \$1.25
Package of 100 8.50
1000-1999 78.00/M
2000-19,999 73.00/M

Type 274-J Jack

A = $\frac{3}{8}$ inch hex.
B = Panel = $\frac{3}{8}$ inch max.
C = $\frac{1}{4}$ -28

Code Word: STANPARTOP

Package of 10 \$0.75
Package of 100 4.95
1000-1999 46.75/M
2000-19,999 44.00/M

Type 274-X Plug

A = 0.135 inch diam.
B = $\frac{1}{32}$ inch C = $\frac{1}{8}$ inch
D = $\frac{1}{16}$ inch

Code Word: STANPARTIN

Package of 10 \$0.85
Package of 100 6.70
1000-1999 61.00/M
2000-19,999 57.50/M

Type 274-U Plug

A = $\frac{3}{8}$ inch hex. nut.
B = Panel = $\frac{3}{8}$ inch max.
C = $\frac{1}{4}$ -28 D = $\frac{1}{4}$ inch

Code Word: STANPARGOT

Package of 10 \$1.50
Package of 100 13.00

Type 274-D Insulated Plug

A = $\frac{1}{2}$ inch B = $\frac{1}{8}$ inch

Code Word: STANPAREYE

Package of 5 \$2.50
Package of 10 4.00

Type 274-M Double Plug

A = $1\frac{3}{8}$ inches B = $1\frac{3}{8}$ inches

Code Word: STANPARBUG

Unit Price \$0.65
Package of 10 5.50

Type 274-SB Short-Circuit Plug

A = $1\frac{1}{8}$ inches B = $1\frac{1}{4}$ inches

Code Word: STANPARZIP

Unit Price \$1.00

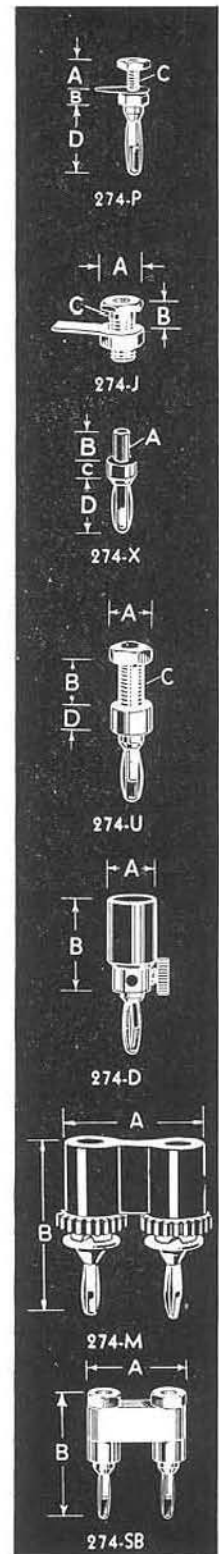

PARTS AND ACCESSORIES

TYPE 274-ND SHIELDED PLUG

This assembly consists of a pair of TYPE 274 Plugs mounted at standard $\frac{3}{4}$ -inch spacing on a yellow phenolic support. A black finish cast-aluminum shield fits over the plugs and is connected to the ground terminal. The assembly is designed to plug into and over

a pair of TYPE 938-W Binding Post Assemblies, mounted on a metal panel.

| Type | Net Weight | Code Word | Price |
|--------|------------|------------|--------|
| 274-ND | 2 OZ. | STAPLUGDOG | \$1.50 |

TYPE 274-NE SHIELDED CONNECTOR

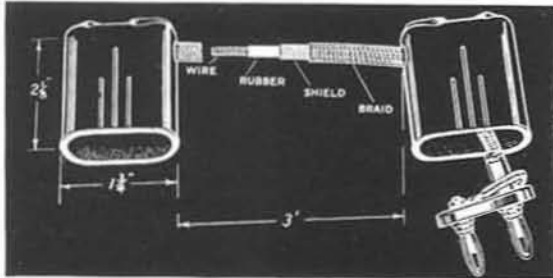

The TYPE 274-NE Shielded Connector consists of a pair of TYPE 274-ND Shielded Plugs with a 3-foot length of shielded concentric cable. The cable has a characteristic impedance of about 40 ohms and the total capacitance of the assembly is of the order of 160 μf .

This connector is useful in high-frequency work and in measurements where precautions in regard to shielding must be observed.

| Type | Net Weight | Code Word | Price |
|--------|---------------------|------------|--------|
| 274-NE | 5 $\frac{3}{4}$ OZ. | STAPLUGEYE | \$4.00 |

TYPE 274-NC SHIELDED CONNECTOR

This assembly is similar to the TYPE 274-NE except that the plugs are the standard TYPE 274-M Double Plug. It is useful in applications where the shielding requirements are not sufficiently severe to justify the use of the TYPE 274-NE but where unshielded leads cannot safely be used.

| Type | Net Weight | Code Word | Price |
|--------|---------------------|------------|--------|
| 274-NC | 2 $\frac{3}{4}$ OZ. | STANPARZOO | \$2.75 |

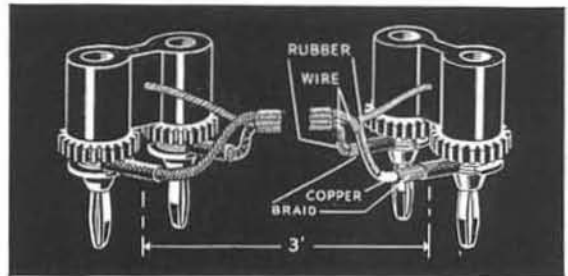

TYPE 674 JUMBO PLUGS AND JACKS

These are rugged, heavy-duty parts designed for use in circuits carrying relatively large currents. They make safe and convenient connectors for currents of 35 amperes or less.

The TYPES 674-P and 674-J are very useful as the plug and jack elements for plug-in units, such as oscillator coils.

Except for size, these parts are very similar in design to the TYPE 274 Plugs and Jacks. Nickel-plated brass is used in the construction except for the plug springs, which are made of specially tempered beryllium copper. Nuts and tinned soldering terminals are supplied.



Type 674-P Jumbo Plug

A = $\frac{3}{4}$ inch
 B = Panel = $\frac{3}{16}$ inch max.
 C = $\frac{3}{8}$ -32 D = $1\frac{1}{16}$ inches

Code Word: STANPARAPE

Package of 10 \$2.50

Type 674-J Jumbo Jack

A = $\frac{3}{4}$ inch
 B = Panel = $\frac{3}{16}$ inch max.
 C = $\frac{3}{2}$ -20

Code Word: STANPARAYE

Package of 10 \$2.20

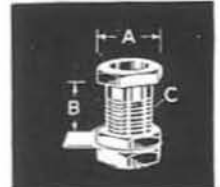

THE QUANTITY DISCOUNTS MENTIONED ON PAGE IV ALSO APPLY TO QUANTITIES OF PACKAGES

TYPE 920 SWITCH

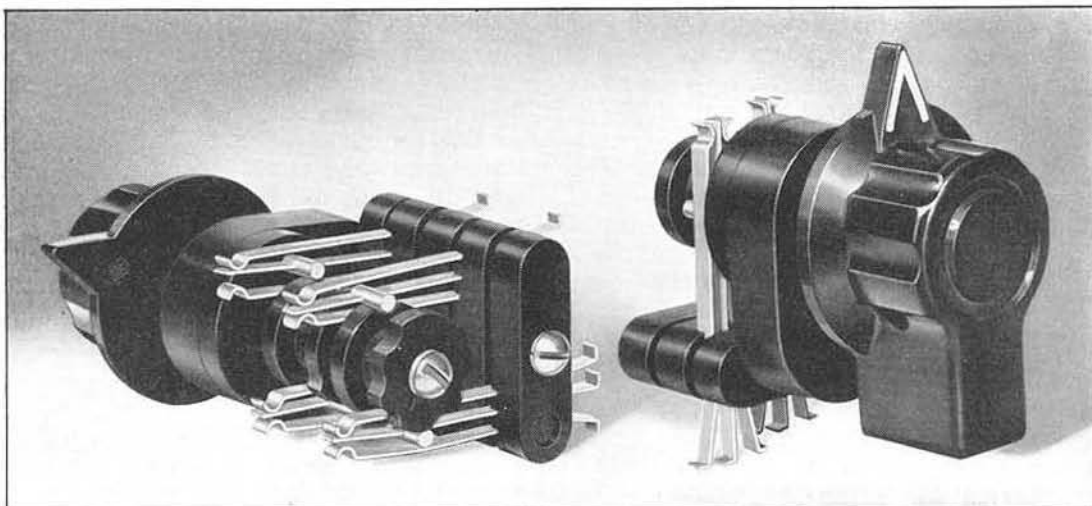

The TYPE 920 Switch is a rotary, cam-actuated, blade-type switch having one cam and one single-pole, double-throw switch per section. A ball detent and limiting stops are built into the switch body; detent positions are $22\frac{1}{2}^\circ$ apart.

The switch body, shaft, cams, and blade holders are molded phenolic. Cams and blade holders are keyed together and held by standard 6-32 machine screws so that sections can be added or removed easily. The switch blades are rolled fine silver on spring-temper phos-

phor-bronze, and are clamped in slots in the blade holders. The blades can be bent to achieve a wide variety of switching arrangements.

The TYPE 920-A is a four-pole switch having 11 positions and so arranged that decade steps (of, say, resistance or capacitance) are obtained when four units having relative magnitudes of 1, 2, 2, and 5 are connected to the four poles. The switch is arranged so that the units can be added in parallel or series combinations.

SPECIFICATIONS

Insulation: Molded phenolic.

Resistance: The d-c resistance of two switch blades plus the contact between them is about 5 milliohms.

Capacitance: The capacitance between two switch blades is about $2.5 \mu\text{f}$.

Voltage and Current Ratings: The breakdown voltage of the insulation is greater than 2000 volts peak, thus allowing a safe operating maximum of 500 volts r-m-s on low-current work. The switch will break the circuit at 500 volts if turned rapidly to the new setting, but voltages above 150 volts may cause destructive arcing if the switch is set between detent positions and the current broken is more than a few milliamperes.

Currents up to 5 amperes can be carried by the switch at low voltage levels.

Terminals: Soldering terminals are an integral part of the switch blades.

Mounting: Two panel holes, one $\frac{5}{8}$ -inch diameter for the shaft boss, and one for the single 10-32 mounting screw. Switch will fit on panels up to $\frac{5}{16}$ inch thick, and knob is supplied.

Dimensions: Panel space, $1\frac{1}{8} \times 1\frac{1}{4}$ inches over-all; depth behind panel, TYPE 920-B, $1\frac{3}{8}$ inches; TYPES 920-A and -C, 2 inches.

Net Weight: TYPE 920-B, $2\frac{1}{2}$ ounces; TYPES 920-A and -C, 3 ounces.

| Type | | Code Word | Price |
|-------|-------------------------------|-----------|--------|
| 920-A | 4-Pole, Decade (1-2-2-5)..... | NINNY | \$5.50 |
| 920-B | 2-Pole, Double-Throw..... | NITRE | 3.50 |
| 920-C | 4-Pole, Double-Throw..... | NOBLE | 4.50 |

OTHER SWITCHES

Two other decade switches, TYPES 510-P3 and 380-P3, are listed on pages 29 and 55, respectively.



PARTS AND ACCESSORIES

TYPE 119 RADIO-FREQUENCY CHOKE

USES: TYPE 119 Choke is useful not only as a radio-frequency choke in vacuum-tube circuits, but also as an inductance element in filters and tuned circuits.

DESCRIPTION: The winding is the so-called helical type, composed of a large number of thin, spiral-wound pies. TYPE 119-B uses a dust-type core. The coil is mounted in a molded phenolic housing which is effectively sealed against moisture penetration.

FEATURES: There is only one significant point of resonance, all minor resonances being practically eliminated by the method of winding and assembling. The shunt capacitance is low, so that the choke can be used at frequencies as high as 40 megacycles. The use of an iron-dust core in TYPE 119-B makes possible a high-inductance unit with very little increase in capacitance and resistance. The capacitance and conductance of this choke as a function of frequency are shown on page 73.

SPECIFICATIONS

Accuracy of Inductance: $\pm 20\%$.

Maximum Current: 60 ma.

Dimensions: (Height) 2 inches; for base dimensions, see sketch.

Net Weight: TYPE 119-A, 2½ oz.; TYPE 119-B, 3 oz.

| Type | Inductance | Capacitance | D-C Resistance |
|-------|------------|--------------------|----------------|
| 119-A | 0.25 h | 4 $\mu\mu\text{f}$ | 450 Ω |
| 119-B | 0.5 h | 5 $\mu\mu\text{f}$ | 450 Ω |

At the left is a view of the TYPE 119 Choke and at the right a sketch of the base dimensions.

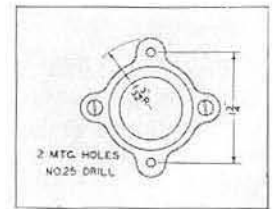
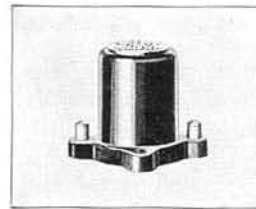

| Type | Code Word | Price |
|-------|-----------------------------|--------|
| 119-A | Radio-Frequency Choke | IMAGE |
| 119-B | Radio-Frequency Choke | IMBED |
| | | \$2.25 |
| | | 3.00 |

TYPE CAP-35 POWER CORD

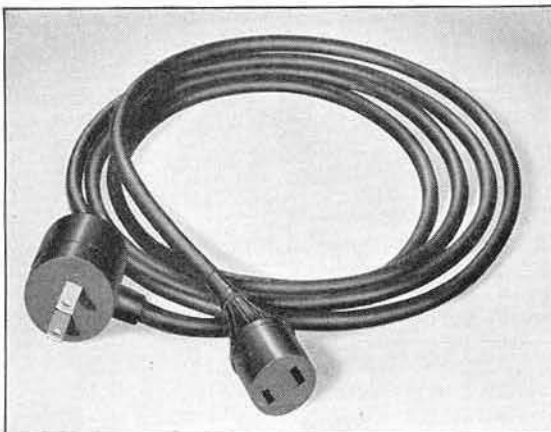

This power cord is supplied with almost all General Radio a-c operated instruments, and is listed here for the convenience of those customers who require occasional replacements.

The TYPE CAP-35 Power Cord is seven feet long, and has the plug and connector bodies molded in rubber directly to the two-conductor, No. 18, TYPE SJ, stranded cord.

| Type | Net Weight | Code Word | Price |
|--------|------------|-----------|--------|
| CAP-35 | Power Cord | 8 oz. | CORDY |
| | | | \$1.75 |

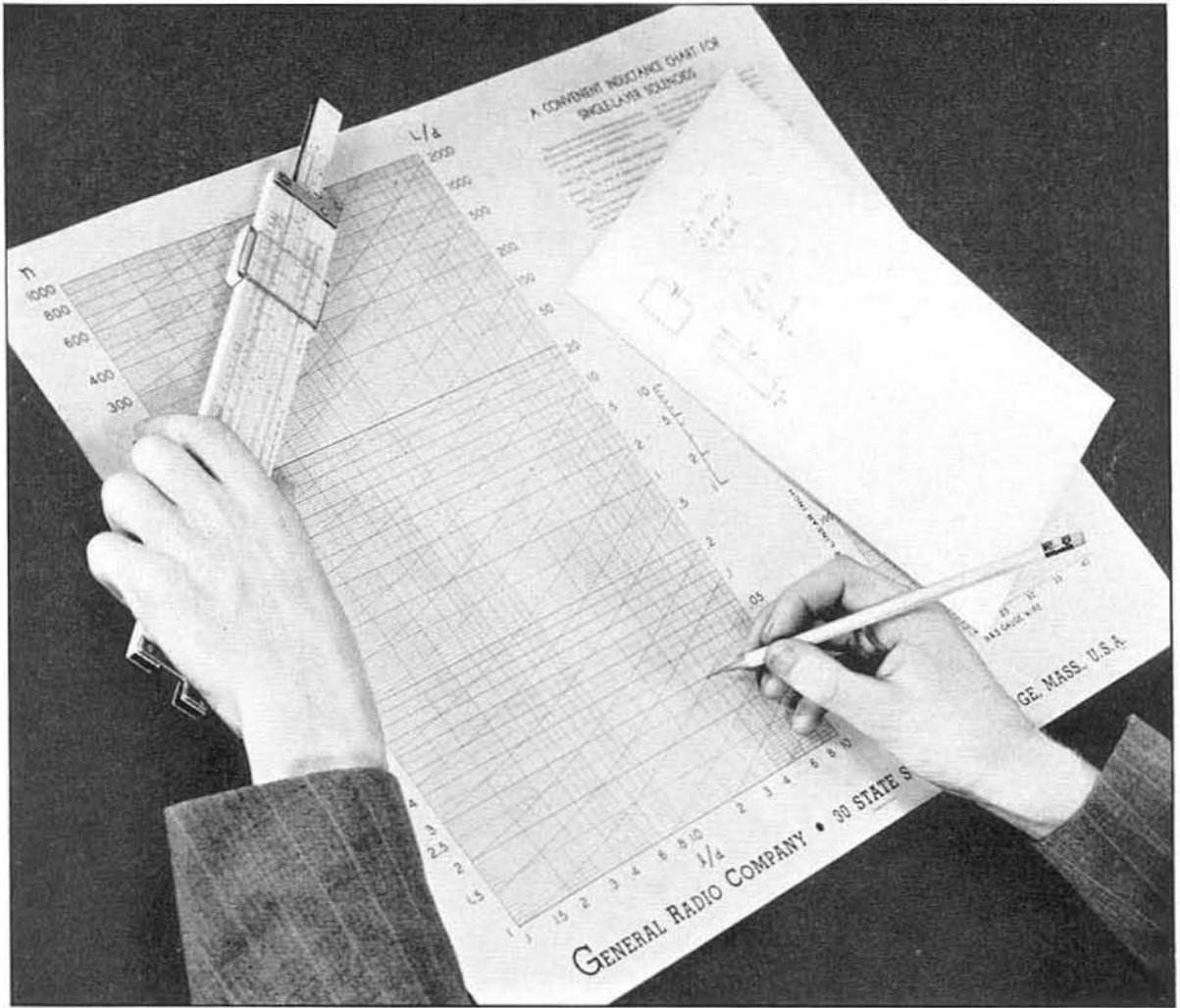

APPENDIX

REACTANCE CHARTS

•

INDUCTANCE CHART

•

WIRE CHART

•

DECIBEL CONVERSION TABLES



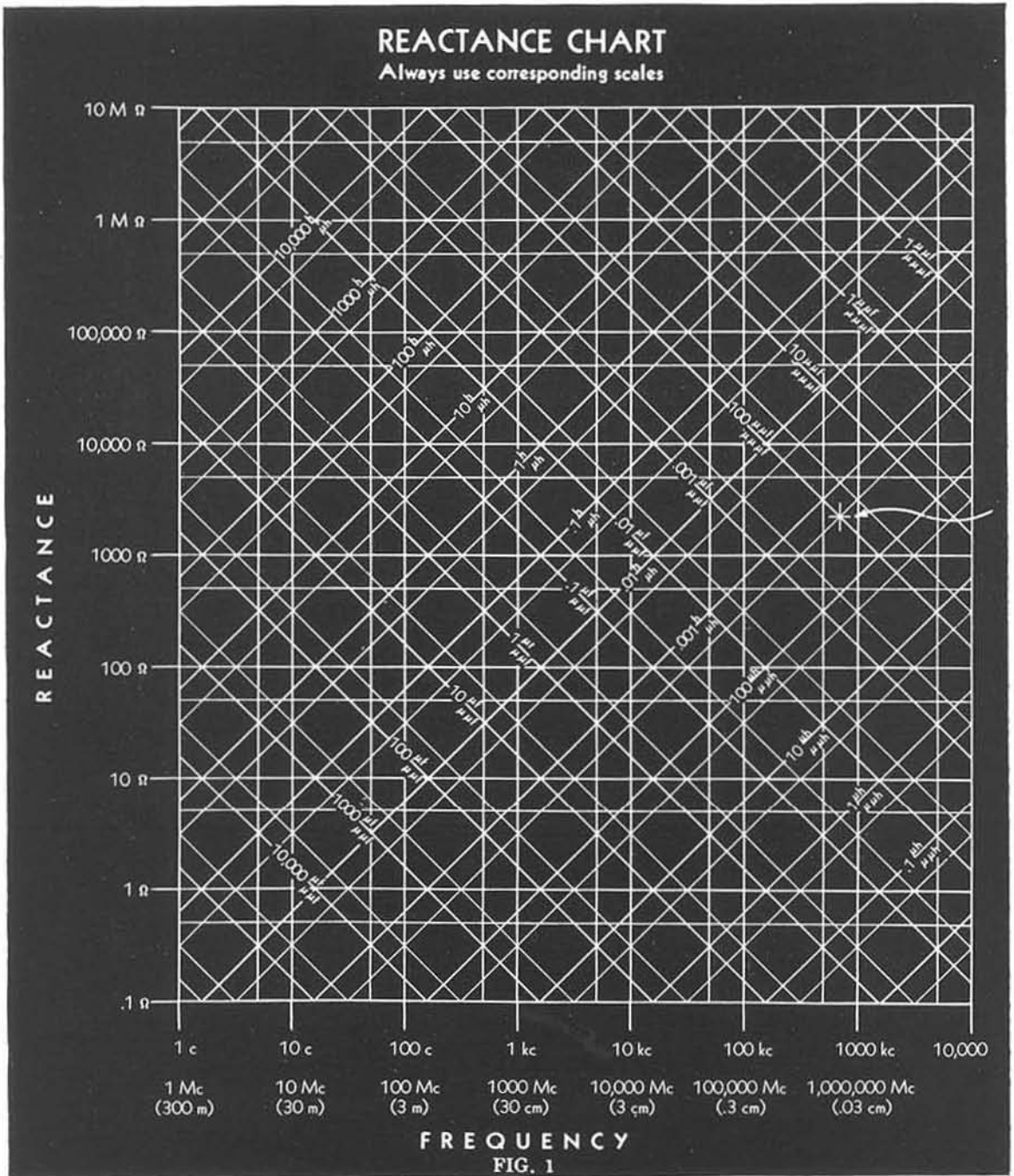

The accompanying chart may be used to find:

- (1) The reactance of a given inductance at a given frequency.
- (2) The reactance of a given capacitance at a given frequency.
- (3) The resonant frequency of a given inductance and capacitance.

In order to facilitate the determination of magnitude of the quantities involved to two or three significant figures the chart is divided into two parts. Figure 1 is the complete chart to be used for rough calculations. Figure

2, which is a single decade of Figure 1 enlarged approximately 7 times, is to be used where the significant two or three figures are to be determined.

TO FIND REACTANCE

Enter the charts vertically from the bottom (frequency) and along the lines slanting upward to the left (capacitance) or to the right (inductance). Corresponding scales (upper or lower) must be used throughout. Project horizontally to the left from the intersection and read reactance.

Write for Enlarged Copies of These Charts



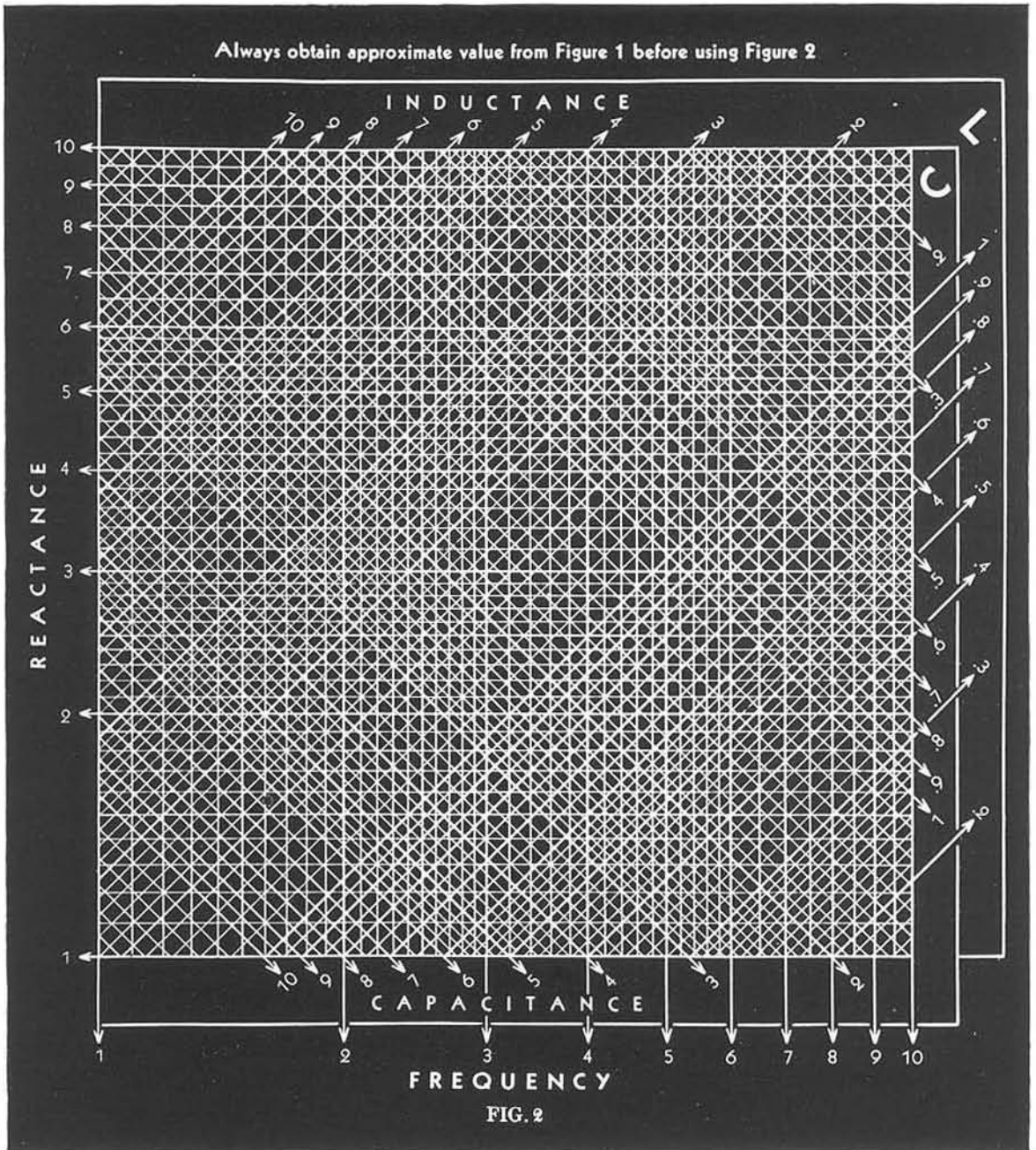

TO FIND RESONANT FREQUENCY

Enter the slanting lines for the given inductance and capacitance. Project downward from their intersection and read resonant frequency from the bottom scale. Corresponding scales (upper or lower) must be used throughout.

Example: The sample point indicated (Figure 1) corresponds to a frequency of about 700 kc and an inductance of 500 μ h, or a capacitance of 100 μ f, giving in either case a reactance of about 2000 ohms. The resonant frequency of a circuit containing these values of inductance and capacitance is, of course, 700 kc, approximately.

USE OF FIGURE 2

Figure 2 is used to obtain additional precision of reading but does not place the decimal point which must be located from a preliminary entry on Figure 1. Since the chart necessarily requires two logarithmic decades for inductance and capacitance for every single decade of frequency and reactance, unless the correct decade for L and C is chosen, the calculated values of reactance and frequency will be in error by a factor of 3.16.

Example: (Continued.) The reactance corresponding to 500 μ h or 100 μ f is 2230 ohms at 712 kc, their resonant frequency.

APPENDIX

A CONVENIENT INDUCTANCE CHART FOR SINGLE-LAYER SOLENOIDS

The chart on the next page is used for determining the number of turns necessary to obtain a given inductance on a given winding form. The chart below is plotted from standard winding data published by wire manufacturers and is used to determine the wire size.

The variables are n , the number of turns, and l/d the ratio of winding length to winding diameter. The ratio of inductance to diameter of winding L/d is used as a parameter.

The curves were computed from the expression given in Circular 74 of the U. S. Bureau of Standards,* which, using the terminology of the chart, may be written,

$$L = \frac{.02508 n^2 d^2}{l} K \quad (1)$$

where L is the inductance in μh , K is Nagaoka's constant, and d and l are in inches.

For a given inductance the number of turns is then,

$$n = \sqrt{\left(\frac{L}{d}\right) \left(\frac{l}{d}\right) (39.88) \left(\frac{1}{K}\right)} \quad (2)$$

This form of the expression is particularly convenient because, in designing coils, the engineer usually starts with a given coil form (l/d known) and needs a given inductance L (L/d easily calculated).

Since Nagaoka's constant depends on the ratio l/d , the use of this ratio for the horizontal scale makes all the curves parallel, so that, in plotting them, only one curve need be calculated. The others can be drawn from a template.

For interpolating between curves, a logarithmic scale covering one decade of L/d is shown at the right of the chart.

EXAMPLE

As an example of the use of these charts, consider the problem of designing a coil of $100 \mu\text{h}$ inductance on a winding form two inches in diameter, with an available winding space of two inches. The quantity l/d is unity and L/d is 50. Entering the chart at $L/d = 50$ and following down the curve at the vertical line $l/d = 1$, we find that n , as indicated by the left hand vertical scale, is 54 turns.

With a winding space of two inches, this is equivalent to 27 turns per linear inch, close wound. The second chart shows that No. 18 enamel or single-silk-, No. 20 double-silk-, or single-cotton- or No. 22 double-cotton-covered wire would be used close wound. No. 25 bare wire, double spaced, could also be used.

*"Radio Instruments and Measurements," p. 252.

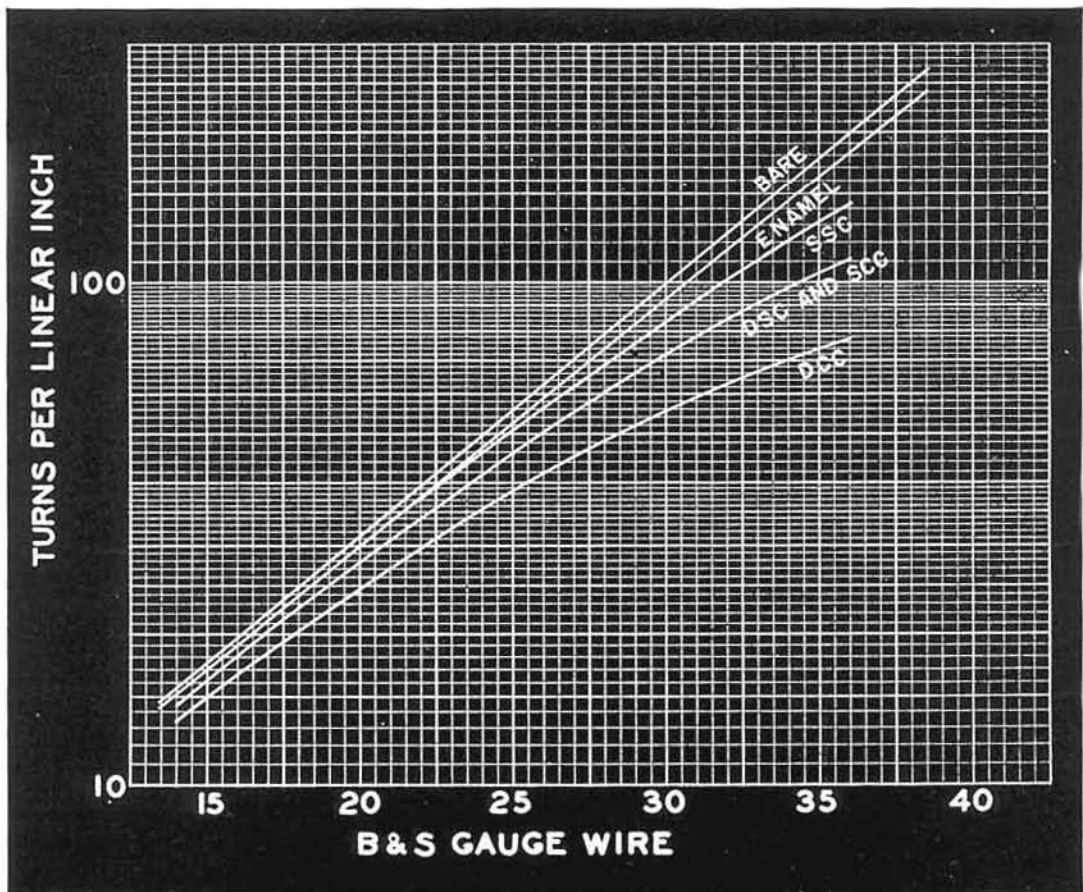

INDUCTANCE CHART

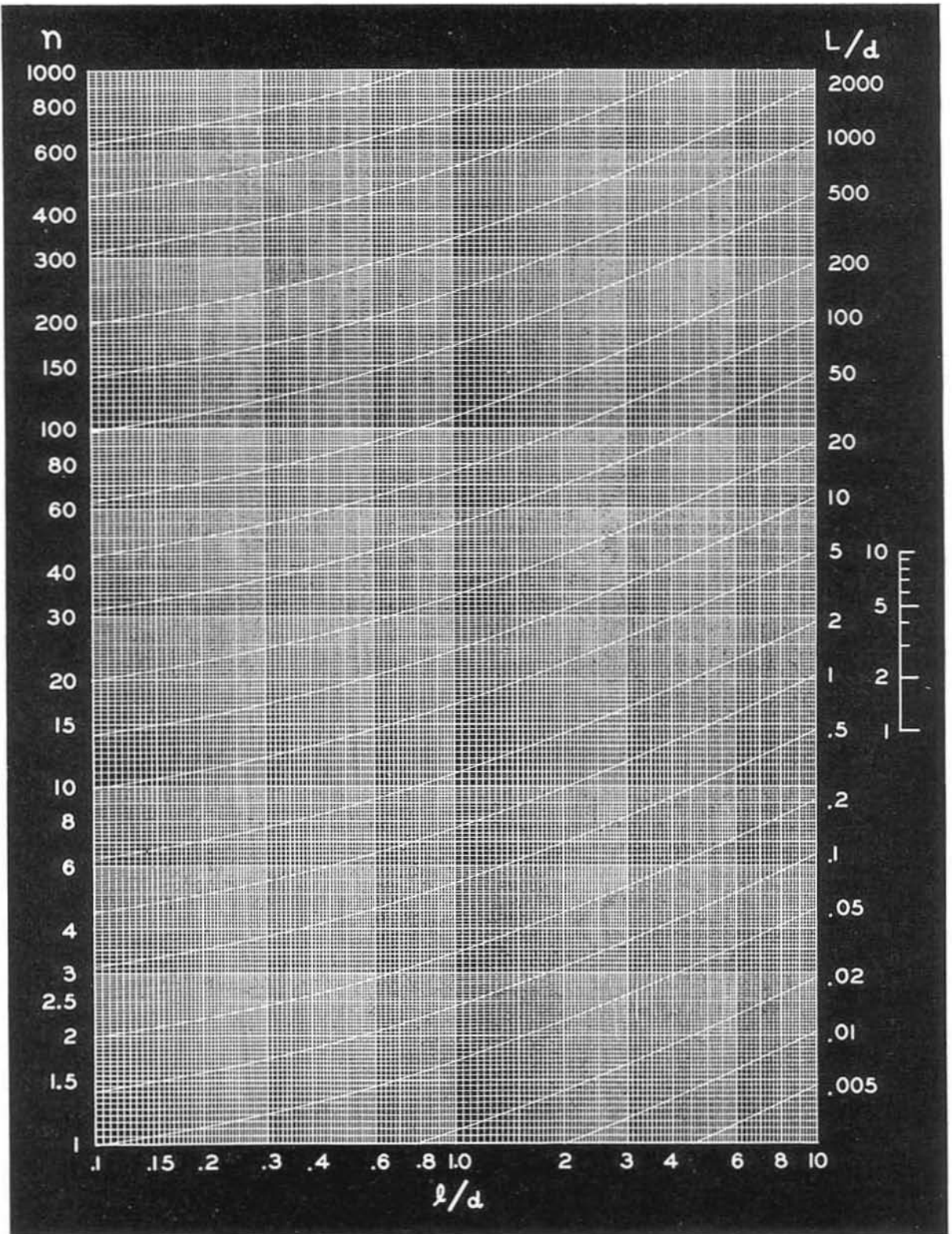

Write for Enlarged Copies of These Charts



DECIBEL CONVERSION TABLES

It is convenient in measurements and calculations on communications systems to express the ratio between any two amounts of electric or acoustic power in units on a logarithmic scale. The *decibel* (1/10th of the *bel*) on the briggisian or base-10 scale and the *neper* on the napierian or base-*e* scale are in almost universal use for this purpose.

Since voltage and current are related to power by impedance, both the *decibel* and the *neper* can be used to express voltage and current ratios, if care is taken to account for

the impedances associated with them. In a similar manner the corresponding acoustical quantities can be compared.

Table I and Table II on the following pages have been prepared to facilitate making conversions in either direction between the number of *decibels* and the corresponding power, voltage, and current ratios. Both tables can also be used for *nepers* and the *mile of standard cable* by applying the conversion factors from the table on the opposite page.

Decibel — The number of decibels N_{db} corresponding to the ratio between two amounts of power P_1 and P_2 is

$$N_{db} = 10 \log_{10} \frac{P_1}{P_2} \tag{1}$$

When two voltages E_1 and E_2 or two currents I_1 and I_2 operate in identical impedances,

$$N_{db} = 20 \log_{10} \frac{E_1}{E_2} \tag{2}$$

and
$$N_{db} = 20 \log_{10} \frac{I_1}{I_2} \tag{3}$$

If E_1 and E_2 or I_1 and I_2 operate in unequal impedances,

$$N_{db} = 20 \log_{10} \frac{E_1}{E_2} + 10 \log_{10} \frac{Z_2}{Z_1} + 10 \log_{10} \frac{k_1}{k_2} \tag{4}$$

and
$$N_{db} = 20 \log_{10} \frac{I_1}{I_2} + 10 \log_{10} \frac{Z_1}{Z_2} + 10 \log_{10} \frac{k_1}{k_2} \tag{5}$$

where Z_1 and Z_2 are the absolute magnitudes of the corresponding impedances and k_1 and k_2 are the values of power factor for the impedances. E_1 , E_2 , I_1 , and I_2 are also the absolute magnitudes of the corresponding quantities. Note that Table I and Table II

can be used to evaluate the impedance and power factor terms, since both are similar to the expression for power ratio, equation (1).

Neper — The number of nepers N_{nep} corresponding to a power ratio $\frac{P_1}{P_2}$ is

$$N_{nep} = \frac{1}{2} \log_e \frac{P_1}{P_2} \tag{6}$$

For voltage ratios $\frac{E_1}{E_2}$ or current ratios $\frac{I_1}{I_2}$

working in identical impedances,

$$N_{nep} = \log_e \frac{E_1}{E_2} \tag{7}$$

and
$$N_{nep} = \log_e \frac{I_1}{I_2}$$

When E_1 and E_2 or I_1 and I_2 operate in unequal impedances,

$$N_{nep} = \log_e \frac{E_1}{E_2} + \frac{1}{2} \log_e \frac{Z_2}{Z_1} + \frac{1}{2} \log_e \frac{k_1}{k_2} \tag{8}$$

and

$$N_{nep} = \log_e \frac{I_1}{I_2} + \frac{1}{2} \log_e \frac{Z_1}{Z_2} + \frac{1}{2} \log_e \frac{k_1}{k_2} \tag{9}$$

where Z_1 and Z_2 and k_1 and k_2 are as in equations (4) and (5).



DECIBEL CONVERSION TABLES

RELATIONS BETWEEN DECIBELS, NEPERS, AND MILES OF STANDARD CABLE

| <i>Multiply</i> | <i>By</i> | <i>To Find</i> |
|-------------------------|-----------|-------------------------|
| decibels | .1151 | nepers |
| decibels | 1.056 | miles of standard cable |
| miles of standard cable | .947 | decibels |
| miles of standard cable | .109 | nepers |
| nepers | 8.686 | decibels |
| nepers | 9.175 | miles of standard cable |

TO FIND VALUES OUTSIDE THE RANGE OF CONVERSION TABLES

Values outside the range of either Table I or Table II on the following pages can be

readily found with the help of the following simple rules:

TABLE I: DECIBELS TO VOLTAGE AND POWER RATIOS

Number of decibels positive (+): Subtract +20 decibels successively from the given number of decibels until the remainder falls within range of Table I. *To find the voltage ratio*, multiply the corresponding value from the right-hand voltage-ratio column by 10 for each time you subtracted 20 db. *To find the power ratio*, multiply the corresponding value from the right-hand power-ratio column by 100 for each time you subtracted 20 db.

Example — Given: 49.2 db.
 $49.2 \text{ db} - 20 \text{ db} - 20 \text{ db} = 9.2 \text{ db}$
Voltage ratio: 9.2 db \rightarrow 2.884
 $2.884 \times 10 \times 10 = 288.4 \rightarrow 49.2 \text{ db}$
Power ratio: 9.2 db \rightarrow 8.318
 $8.318 \times 100 \times 100 = 83180 \rightarrow 49.2 \text{ db}$

Number of decibels negative (-): Add +20 decibels successively to the given number of decibels until the sum falls within the range of Table I. *For the voltage ratio*, divide the value from the left-hand voltage-ratio column by 10 for each time you added 20 db. *For the power ratio*, divide the value from the left-hand power-ratio column by 100 for each time you added 20 db.

Example — Given: -49.2 db
 $-49.2 \text{ db} + 20 \text{ db} + 20 \text{ db} = -9.2 \text{ db}$
Voltage ratio: -9.2 db \rightarrow .3467
 $.3467 \times 1/10 \times 1/10 = .003467 \rightarrow$
 -49.2 db
Power ratio: -9.2 db \rightarrow .1202
 $.1202 \times 1/100 \times 1/100 = .00001202 \rightarrow$
 -49.2 db

TABLE II: VOLTAGE RATIOS TO DECIBELS

For ratios smaller than those in table—Multiply the given ratio by 10 successively until the product can be found in the table. From the number of decibels thus found, subtract +20 decibels for each time you multiplied by 10.

Example—Given: Voltage ratio = .0131
 $.0131 \times 10 \times 10 = 1.31$
 From Table II, 1.31 \rightarrow 2.345 db
 $2.345 \text{ db} - 20 \text{ db} - 20 \text{ db} = -37.655 \text{ db}$

For ratios greater than those in table—Divide the given ratio by 10 successively until the remainder can be found in the table. To the number of decibels thus found, add +20 db for each time you divided by 10.

Example—Given: Voltage ratio = 712
 $712 \times 1/10 \times 1/10 = 7.12$
 From Table II, 7.12 \rightarrow 17.050 db
 $17.050 \text{ db} + 20 \text{ db} + 20 \text{ db} = 57.050 \text{ db}$

APPENDIX

TABLE I

GIVEN: Decibels

TO FIND: Power and $\left\{ \begin{matrix} \text{Voltage} \\ \text{Current} \end{matrix} \right\}$ Ratios

TO ACCOUNT FOR THE SIGN OF THE DECIBEL

For positive (+) values of the decibel—Both voltage and power ratios are greater than unity. Use the two right-hand columns.

For negative (-) values of the decibel—Both voltage and power ratios are less than unity. Use the two left-hand columns.

Example—Given: ± 9.1 db. Find:

| | Power Ratio | Voltage Ratio |
|---------|-------------|---------------|
| +9.1 db | 8.128 | 2.851 |
| -9.1 db | 0.1230 | 0.3508 |

| ← -db+ → | | | | | ← -db+ → | | | | |
|---------------|-------------|-----|---------------|-------------|---------------|-------------|-----|---------------|-------------|
| Voltage Ratio | Power Ratio | db | Voltage Ratio | Power Ratio | Voltage Ratio | Power Ratio | db | Voltage Ratio | Power Ratio |
| 1.0000 | 1.0000 | 0 | 1.000 | 1.000 | .5623 | .3162 | 5.0 | 1.778 | 3.162 |
| .9886 | .9772 | .1 | 1.012 | 1.023 | .5559 | .3090 | 5.1 | 1.799 | 3.236 |
| .9772 | .9550 | .2 | 1.023 | 1.047 | .5495 | .3020 | 5.2 | 1.820 | 3.311 |
| .9661 | .9333 | .3 | 1.035 | 1.072 | .5433 | .2951 | 5.3 | 1.841 | 3.388 |
| .9550 | .9120 | .4 | 1.047 | 1.096 | .5370 | .2884 | 5.4 | 1.862 | 3.467 |
| .9441 | .8913 | .5 | 1.059 | 1.122 | .5309 | .2818 | 5.5 | 1.884 | 3.548 |
| .9333 | .8710 | .6 | 1.072 | 1.148 | .5248 | .2754 | 5.6 | 1.905 | 3.631 |
| .9226 | .8511 | .7 | 1.084 | 1.175 | .5188 | .2692 | 5.7 | 1.928 | 3.715 |
| .9120 | .8318 | .8 | 1.096 | 1.202 | .5129 | .2630 | 5.8 | 1.950 | 3.802 |
| .9016 | .8128 | .9 | 1.109 | 1.230 | .5070 | .2570 | 5.9 | 1.972 | 3.890 |
| .8913 | .7943 | 1.0 | 1.122 | 1.259 | .5012 | .2512 | 6.0 | 1.995 | 3.981 |
| .8810 | .7762 | 1.1 | 1.135 | 1.288 | .4955 | .2455 | 6.1 | 2.018 | 4.074 |
| .8710 | .7586 | 1.2 | 1.148 | 1.318 | .4898 | .2399 | 6.2 | 2.042 | 4.169 |
| .8610 | .7413 | 1.3 | 1.161 | 1.349 | .4842 | .2344 | 6.3 | 2.065 | 4.266 |
| .8511 | .7244 | 1.4 | 1.175 | 1.380 | .4786 | .2291 | 6.4 | 2.089 | 4.365 |
| .8414 | .7079 | 1.5 | 1.189 | 1.413 | .4732 | .2239 | 6.5 | 2.113 | 4.467 |
| .8318 | .6918 | 1.6 | 1.202 | 1.445 | .4677 | .2188 | 6.6 | 2.138 | 4.571 |
| .8222 | .6761 | 1.7 | 1.216 | 1.479 | .4624 | .2138 | 6.7 | 2.163 | 4.677 |
| .8128 | .6607 | 1.8 | 1.230 | 1.514 | .4571 | .2089 | 6.8 | 2.188 | 4.786 |
| .8035 | .6457 | 1.9 | 1.245 | 1.549 | .4519 | .2042 | 6.9 | 2.213 | 4.898 |
| .7943 | .6310 | 2.0 | 1.259 | 1.585 | .4467 | .1995 | 7.0 | 2.239 | 5.012 |
| .7852 | .6166 | 2.1 | 1.274 | 1.622 | .4416 | .1950 | 7.1 | 2.265 | 5.129 |
| .7762 | .6026 | 2.2 | 1.288 | 1.660 | .4365 | .1905 | 7.2 | 2.291 | 5.248 |
| .7674 | .5888 | 2.3 | 1.303 | 1.698 | .4315 | .1862 | 7.3 | 2.317 | 5.370 |
| .7586 | .5754 | 2.4 | 1.318 | 1.738 | .4266 | .1820 | 7.4 | 2.344 | 5.495 |
| .7499 | .5623 | 2.5 | 1.334 | 1.778 | .4217 | .1778 | 7.5 | 2.371 | 5.623 |
| .7413 | .5495 | 2.6 | 1.349 | 1.820 | .4169 | .1738 | 7.6 | 2.399 | 5.754 |
| .7328 | .5370 | 2.7 | 1.365 | 1.862 | .4121 | .1698 | 7.7 | 2.427 | 5.888 |
| .7244 | .5248 | 2.8 | 1.380 | 1.905 | .4074 | .1660 | 7.8 | 2.455 | 6.026 |
| .7161 | .5129 | 2.9 | 1.396 | 1.950 | .4027 | .1622 | 7.9 | 2.483 | 6.166 |
| .7079 | .5012 | 3.0 | 1.413 | 1.995 | .3981 | .1585 | 8.0 | 2.512 | 6.310 |
| .6998 | .4898 | 3.1 | 1.429 | 2.042 | .3936 | .1549 | 8.1 | 2.541 | 6.457 |
| .6918 | .4786 | 3.2 | 1.445 | 2.089 | .3890 | .1514 | 8.2 | 2.570 | 6.607 |
| .6839 | .4677 | 3.3 | 1.462 | 2.138 | .3846 | .1479 | 8.3 | 2.600 | 6.761 |
| .6761 | .4571 | 3.4 | 1.479 | 2.188 | .3802 | .1445 | 8.4 | 2.630 | 6.918 |
| .6683 | .4467 | 3.5 | 1.496 | 2.239 | .3758 | .1413 | 8.5 | 2.661 | 7.079 |
| .6607 | .4365 | 3.6 | 1.514 | 2.291 | .3715 | .1380 | 8.6 | 2.692 | 7.244 |
| .6531 | .4266 | 3.7 | 1.531 | 2.344 | .3673 | .1349 | 8.7 | 2.723 | 7.413 |
| .6457 | .4169 | 3.8 | 1.549 | 2.399 | .3631 | .1318 | 8.8 | 2.754 | 7.586 |
| .6383 | .4074 | 3.9 | 1.567 | 2.455 | .3589 | .1288 | 8.9 | 2.786 | 7.762 |
| .6310 | .3981 | 4.0 | 1.585 | 2.512 | .3548 | .1259 | 9.0 | 2.818 | 7.943 |
| .6237 | .3890 | 4.1 | 1.603 | 2.570 | .3508 | .1230 | 9.1 | 2.851 | 8.128 |
| .6166 | .3802 | 4.2 | 1.622 | 2.630 | .3467 | .1202 | 9.2 | 2.884 | 8.318 |
| .6095 | .3715 | 4.3 | 1.641 | 2.692 | .3428 | .1175 | 9.3 | 2.917 | 8.511 |
| .6026 | .3631 | 4.4 | 1.660 | 2.754 | .3388 | .1148 | 9.4 | 2.951 | 8.710 |
| .5957 | .3548 | 4.5 | 1.679 | 2.818 | .3350 | .1122 | 9.5 | 2.985 | 8.913 |
| .5888 | .3467 | 4.6 | 1.698 | 2.884 | .3311 | .1096 | 9.6 | 3.020 | 9.120 |
| .5821 | .3388 | 4.7 | 1.718 | 2.951 | .3273 | .1072 | 9.7 | 3.055 | 9.333 |
| .5754 | .3311 | 4.8 | 1.738 | 3.020 | .3236 | .1047 | 9.8 | 3.090 | 9.550 |
| .5689 | .3236 | 4.9 | 1.758 | 3.090 | .3199 | .1023 | 9.9 | 3.126 | 9.772 |



APPENDIX

TABLE II

GIVEN: $\left\{ \begin{matrix} \text{Voltage} \\ \text{Current} \end{matrix} \right\}$ Ratio

TO FIND: Decibels

POWER RATIOS

To find the number of decibels corresponding to a given power ratio—Assume the given power ratio to be a voltage ratio and find the corresponding number of decibels from the table. The desired result is exactly one-half of the number of decibels thus found.

Example—Given: a power ratio of 3.41.
Find: 3.41 in the table:

3.41 → 10.655 db (voltage)
10.655 db × ½ = 5.328 db (power)

| Voltage Ratio | .00 | .01 | .02 | .03 | .04 | .05 | .06 | .07 | .08 | .09 |
|---------------|--------|--------|--------|--------|--------|--------|--------|--------|--------|--------|
| 1.0 | .000 | .086 | .172 | .257 | .341 | .424 | .506 | .588 | .668 | .749 |
| 1.1 | .828 | .906 | .984 | 1.062 | 1.138 | 1.214 | 1.289 | 1.364 | 1.438 | 1.511 |
| 1.2 | 1.584 | 1.656 | 1.727 | 1.798 | 1.868 | 1.938 | 2.007 | 2.076 | 2.144 | 2.212 |
| 1.3 | 2.279 | 2.345 | 2.411 | 2.477 | 2.542 | 2.607 | 2.671 | 2.734 | 2.798 | 2.860 |
| 1.4 | 2.923 | 2.984 | 3.046 | 3.107 | 3.167 | 3.227 | 3.287 | 3.346 | 3.405 | 3.464 |
| 1.5 | 3.522 | 3.580 | 3.637 | 3.694 | 3.750 | 3.807 | 3.862 | 3.918 | 3.973 | 4.028 |
| 1.6 | 4.082 | 4.137 | 4.190 | 4.244 | 4.297 | 4.350 | 4.402 | 4.454 | 4.506 | 4.558 |
| 1.7 | 4.609 | 4.660 | 4.711 | 4.761 | 4.811 | 4.861 | 4.910 | 4.959 | 5.008 | 5.057 |
| 1.8 | 5.105 | 5.154 | 5.201 | 5.249 | 5.296 | 5.343 | 5.390 | 5.437 | 5.483 | 5.529 |
| 1.9 | 5.575 | 5.621 | 5.666 | 5.711 | 5.756 | 5.801 | 5.845 | 5.889 | 5.933 | 5.977 |
| 2.0 | 6.021 | 6.064 | 6.107 | 6.150 | 6.193 | 6.235 | 6.277 | 6.319 | 6.361 | 6.403 |
| 2.1 | 6.444 | 6.486 | 6.527 | 6.568 | 6.608 | 6.649 | 6.689 | 6.729 | 6.769 | 6.809 |
| 2.2 | 6.848 | 6.888 | 6.927 | 6.966 | 7.008 | 7.044 | 7.082 | 7.121 | 7.159 | 7.197 |
| 2.3 | 7.235 | 7.272 | 7.310 | 7.347 | 7.384 | 7.421 | 7.458 | 7.495 | 7.532 | 7.568 |
| 2.4 | 7.604 | 7.640 | 7.676 | 7.712 | 7.748 | 7.783 | 7.819 | 7.854 | 7.889 | 7.924 |
| 2.5 | 7.959 | 7.993 | 8.028 | 8.062 | 8.097 | 8.131 | 8.165 | 8.199 | 8.232 | 8.266 |
| 2.6 | 8.299 | 8.333 | 8.366 | 8.399 | 8.432 | 8.465 | 8.498 | 8.530 | 8.563 | 8.595 |
| 2.7 | 8.627 | 8.659 | 8.691 | 8.723 | 8.755 | 8.787 | 8.818 | 8.850 | 8.881 | 8.912 |
| 2.8 | 8.943 | 8.974 | 9.005 | 9.036 | 9.066 | 9.097 | 9.127 | 9.158 | 9.188 | 9.218 |
| 2.9 | 9.248 | 9.278 | 9.308 | 9.337 | 9.367 | 9.396 | 9.426 | 9.455 | 9.484 | 9.513 |
| 3.0 | 9.542 | 9.571 | 9.600 | 9.629 | 9.657 | 9.686 | 9.714 | 9.743 | 9.771 | 9.799 |
| 3.1 | 9.827 | 9.855 | 9.883 | 9.911 | 9.939 | 9.966 | 9.994 | 10.021 | 10.049 | 10.076 |
| 3.2 | 10.103 | 10.130 | 10.157 | 10.184 | 10.211 | 10.238 | 10.264 | 10.291 | 10.317 | 10.344 |
| 3.3 | 10.370 | 10.397 | 10.423 | 10.449 | 10.475 | 10.501 | 10.527 | 10.553 | 10.578 | 10.604 |
| 3.4 | 10.630 | 10.655 | 10.681 | 10.706 | 10.731 | 10.756 | 10.782 | 10.807 | 10.832 | 10.857 |
| 3.5 | 10.881 | 10.906 | 10.931 | 10.955 | 10.980 | 11.005 | 11.029 | 11.053 | 11.078 | 11.102 |
| 3.6 | 11.126 | 11.150 | 11.174 | 11.198 | 11.222 | 11.246 | 11.270 | 11.293 | 11.317 | 11.341 |
| 3.7 | 11.364 | 11.387 | 11.411 | 11.434 | 11.457 | 11.481 | 11.504 | 11.527 | 11.550 | 11.573 |
| 3.8 | 11.596 | 11.618 | 11.641 | 11.664 | 11.687 | 11.709 | 11.732 | 11.754 | 11.777 | 11.799 |
| 3.9 | 11.821 | 11.844 | 11.866 | 11.888 | 11.910 | 11.932 | 11.954 | 11.976 | 11.998 | 12.019 |
| 4.0 | 12.041 | 12.063 | 12.085 | 12.106 | 12.128 | 12.149 | 12.171 | 12.192 | 12.213 | 12.234 |
| 4.1 | 12.256 | 12.277 | 12.298 | 12.319 | 12.340 | 12.361 | 12.382 | 12.403 | 12.424 | 12.444 |
| 4.2 | 12.465 | 12.486 | 12.506 | 12.527 | 12.547 | 12.568 | 12.588 | 12.609 | 12.629 | 12.649 |
| 4.3 | 12.669 | 12.690 | 12.710 | 12.730 | 12.750 | 12.770 | 12.790 | 12.810 | 12.829 | 12.849 |
| 4.4 | 12.869 | 12.889 | 12.908 | 12.928 | 12.948 | 12.967 | 12.987 | 13.006 | 13.026 | 13.045 |
| 4.5 | 13.064 | 13.084 | 13.103 | 13.122 | 13.141 | 13.160 | 13.179 | 13.198 | 13.217 | 13.236 |
| 4.6 | 13.255 | 13.274 | 13.293 | 13.312 | 13.330 | 13.349 | 13.368 | 13.386 | 13.405 | 13.423 |
| 4.7 | 13.442 | 13.460 | 13.479 | 13.497 | 13.516 | 13.534 | 13.552 | 13.570 | 13.589 | 13.607 |
| 4.8 | 13.625 | 13.643 | 13.661 | 13.679 | 13.697 | 13.715 | 13.733 | 13.751 | 13.768 | 13.786 |
| 4.9 | 13.804 | 13.822 | 13.839 | 13.857 | 13.875 | 13.892 | 13.910 | 13.927 | 13.945 | 13.962 |
| 5.0 | 13.979 | 13.997 | 14.014 | 14.031 | 14.049 | 14.066 | 14.083 | 14.100 | 14.117 | 14.134 |
| 5.1 | 14.151 | 14.168 | 14.185 | 14.202 | 14.219 | 14.236 | 14.253 | 14.270 | 14.287 | 14.303 |
| 5.2 | 14.320 | 14.337 | 14.353 | 14.370 | 14.387 | 14.403 | 14.420 | 14.436 | 14.453 | 14.469 |
| 5.3 | 14.486 | 14.502 | 14.518 | 14.535 | 14.551 | 14.567 | 14.583 | 14.599 | 14.616 | 14.632 |
| 5.4 | 14.648 | 14.664 | 14.680 | 14.696 | 14.712 | 14.728 | 14.744 | 14.760 | 14.776 | 14.791 |
| 5.5 | 14.807 | 14.823 | 14.839 | 14.855 | 14.870 | 14.886 | 14.902 | 14.917 | 14.933 | 14.948 |
| 5.6 | 14.964 | 14.979 | 14.995 | 15.010 | 15.026 | 15.041 | 15.056 | 15.072 | 15.087 | 15.102 |
| 5.7 | 15.117 | 15.133 | 15.148 | 15.163 | 15.178 | 15.193 | 15.208 | 15.224 | 15.239 | 15.254 |
| 5.8 | 15.269 | 15.284 | 15.298 | 15.313 | 15.328 | 15.343 | 15.358 | 15.373 | 15.388 | 15.402 |
| 5.9 | 15.417 | 15.432 | 15.446 | 15.461 | 15.476 | 15.490 | 15.505 | 15.519 | 15.534 | 15.549 |



DECIBEL CONVERSION TABLES

TABLE II (continued)

| <i>Voltage Ratio</i> | .00 | .01 | .02 | .03 | .04 | .05 | .06 | .07 | .08 | .09 |
|----------------------|--------|--------|--------|--------|--------|--------|--------|--------|--------|--------|
| 6.0 | 15.563 | 15.577 | 15.592 | 15.606 | 15.621 | 15.635 | 15.649 | 15.664 | 15.678 | 15.692 |
| 6.1 | 15.707 | 15.721 | 15.735 | 15.749 | 15.763 | 15.778 | 15.792 | 15.806 | 15.820 | 15.834 |
| 6.2 | 15.848 | 15.862 | 15.876 | 15.890 | 15.904 | 15.918 | 15.931 | 15.945 | 15.959 | 15.973 |
| 6.3 | 15.987 | 16.001 | 16.014 | 16.028 | 16.042 | 16.055 | 16.069 | 16.083 | 16.096 | 16.110 |
| 6.4 | 16.124 | 16.137 | 16.151 | 16.164 | 16.178 | 16.191 | 16.205 | 16.218 | 16.232 | 16.245 |
| 6.5 | 16.258 | 16.272 | 16.285 | 16.298 | 16.312 | 16.325 | 16.338 | 16.351 | 16.365 | 16.378 |
| 6.6 | 16.391 | 16.404 | 16.417 | 16.430 | 16.443 | 16.456 | 16.469 | 16.483 | 16.496 | 16.509 |
| 6.7 | 16.521 | 16.534 | 16.547 | 16.560 | 16.573 | 16.586 | 16.599 | 16.612 | 16.625 | 16.637 |
| 6.8 | 16.650 | 16.663 | 16.676 | 16.688 | 16.701 | 16.714 | 16.726 | 16.739 | 16.752 | 16.764 |
| 6.9 | 16.777 | 16.790 | 16.802 | 16.815 | 16.827 | 16.840 | 16.852 | 16.865 | 16.877 | 16.890 |
| 7.0 | 16.902 | 16.914 | 16.927 | 16.939 | 16.951 | 16.964 | 16.976 | 16.988 | 17.001 | 17.013 |
| 7.1 | 17.025 | 17.037 | 17.050 | 17.062 | 17.074 | 17.086 | 17.098 | 17.110 | 17.122 | 17.135 |
| 7.2 | 17.147 | 17.159 | 17.171 | 17.183 | 17.195 | 17.207 | 17.219 | 17.231 | 17.243 | 17.255 |
| 7.3 | 17.266 | 17.278 | 17.290 | 17.302 | 17.314 | 17.326 | 17.338 | 17.349 | 17.361 | 17.373 |
| 7.4 | 17.385 | 17.396 | 17.408 | 17.420 | 17.431 | 17.443 | 17.455 | 17.466 | 17.478 | 17.490 |
| 7.5 | 17.501 | 17.513 | 17.524 | 17.536 | 17.547 | 17.559 | 17.570 | 17.582 | 17.593 | 17.605 |
| 7.6 | 17.616 | 17.628 | 17.639 | 17.650 | 17.662 | 17.673 | 17.685 | 17.696 | 17.707 | 17.719 |
| 7.7 | 17.730 | 17.741 | 17.752 | 17.764 | 17.775 | 17.786 | 17.797 | 17.808 | 17.820 | 17.831 |
| 7.8 | 17.842 | 17.853 | 17.864 | 17.875 | 17.886 | 17.897 | 17.908 | 17.919 | 17.931 | 17.942 |
| 7.9 | 17.953 | 17.964 | 17.975 | 17.985 | 17.996 | 18.007 | 18.018 | 18.029 | 18.040 | 18.051 |
| 8.0 | 18.062 | 18.073 | 18.083 | 18.094 | 18.105 | 18.116 | 18.127 | 18.137 | 18.148 | 18.159 |
| 8.1 | 18.170 | 18.180 | 18.191 | 18.202 | 18.212 | 18.223 | 18.234 | 18.244 | 18.255 | 18.266 |
| 8.2 | 18.276 | 18.287 | 18.297 | 18.308 | 18.319 | 18.329 | 18.340 | 18.350 | 18.361 | 18.371 |
| 8.3 | 18.382 | 18.392 | 18.402 | 18.413 | 18.423 | 18.434 | 18.444 | 18.455 | 18.465 | 18.475 |
| 8.4 | 18.486 | 18.496 | 18.506 | 18.517 | 18.527 | 18.537 | 18.547 | 18.558 | 18.568 | 18.578 |
| 8.5 | 18.588 | 18.599 | 18.609 | 18.619 | 18.629 | 18.639 | 18.649 | 18.660 | 18.670 | 18.680 |
| 8.6 | 18.690 | 18.700 | 18.710 | 18.720 | 18.730 | 18.740 | 18.750 | 18.760 | 18.770 | 18.780 |
| 8.7 | 18.790 | 18.800 | 18.810 | 18.820 | 18.830 | 18.840 | 18.850 | 18.860 | 18.870 | 18.880 |
| 8.8 | 18.890 | 18.900 | 18.909 | 18.919 | 18.929 | 18.939 | 18.949 | 18.958 | 18.968 | 18.978 |
| 8.9 | 18.988 | 18.998 | 19.007 | 19.017 | 19.027 | 19.036 | 19.046 | 19.056 | 19.066 | 19.075 |
| 9.0 | 19.085 | 19.094 | 19.104 | 19.114 | 19.123 | 19.133 | 19.143 | 19.152 | 19.162 | 19.171 |
| 9.1 | 19.181 | 19.190 | 19.200 | 19.209 | 19.219 | 19.228 | 19.238 | 19.247 | 19.257 | 19.266 |
| 9.2 | 19.276 | 19.285 | 19.295 | 19.304 | 19.313 | 19.323 | 19.332 | 19.342 | 19.351 | 19.360 |
| 9.3 | 19.370 | 19.379 | 19.388 | 19.398 | 19.407 | 19.416 | 19.426 | 19.435 | 19.444 | 19.453 |
| 9.4 | 19.463 | 19.472 | 19.481 | 19.490 | 19.499 | 19.509 | 19.518 | 19.527 | 19.536 | 19.545 |
| 9.5 | 19.554 | 19.564 | 19.573 | 19.582 | 19.591 | 19.600 | 19.609 | 19.618 | 19.627 | 19.636 |
| 9.6 | 19.645 | 19.654 | 19.664 | 19.673 | 19.682 | 19.691 | 19.700 | 19.709 | 19.718 | 19.726 |
| 9.7 | 19.735 | 19.744 | 19.753 | 19.762 | 19.771 | 19.780 | 19.789 | 19.798 | 19.807 | 19.816 |
| 9.8 | 19.825 | 19.833 | 19.842 | 19.851 | 19.860 | 19.869 | 19.878 | 19.886 | 19.895 | 19.904 |
| 9.9 | 19.913 | 19.921 | 19.930 | 19.939 | 19.948 | 19.956 | 19.965 | 19.974 | 19.983 | 19.991 |

| <i>Voltage Ratio</i> | 0 | 1 | 2 | 3 | 4 | 5 | 6 | 7 | 8 | 9 |
|----------------------|--------|--------|--------|--------|--------|--------|--------|--------|--------|--------|
| 10 | 20.000 | 20.828 | 21.584 | 22.279 | 22.923 | 23.522 | 24.082 | 24.609 | 25.105 | 25.575 |
| 20 | 26.021 | 26.444 | 26.848 | 27.235 | 27.604 | 27.959 | 28.299 | 28.627 | 28.943 | 29.248 |
| 30 | 29.542 | 29.827 | 30.103 | 30.370 | 30.630 | 30.881 | 31.126 | 31.364 | 31.596 | 31.821 |
| 40 | 32.041 | 32.256 | 32.465 | 32.669 | 32.869 | 33.064 | 33.255 | 33.442 | 33.625 | 33.804 |
| 50 | 33.979 | 34.151 | 34.320 | 34.486 | 34.648 | 34.807 | 34.964 | 35.117 | 35.269 | 35.417 |
| 60 | 35.563 | 35.707 | 35.848 | 35.987 | 36.124 | 36.258 | 36.391 | 36.521 | 36.650 | 36.777 |
| 70 | 36.902 | 37.025 | 37.147 | 37.266 | 37.385 | 37.501 | 37.616 | 37.730 | 37.842 | 37.953 |
| 80 | 38.062 | 38.170 | 38.276 | 38.382 | 38.486 | 38.588 | 38.690 | 38.790 | 38.890 | 38.988 |
| 90 | 39.085 | 39.181 | 39.276 | 39.370 | 39.463 | 39.554 | 39.645 | 39.735 | 39.825 | 39.913 |
| 100 | 40.000 | — | — | — | — | — | — | — | — | — |

To find ratios outside the range of this table, see page 217



INDEX BY TYPE NUMBER

| <i>Type</i> | <i>Name</i> | <i>Page</i> | <i>Type</i> | <i>Name</i> | <i>Page</i> |
|-------------|--|-------------|-------------|--|-------------|
| CAP-35 | Power Cord | 210 | 583-A | Output-Power Meter | 154 |
| KN | Fluted Knobs | 202 | 602 | Decade-Resistance Box | 26 |
| V-5 | Variac | 18 | 620-A | Heterodyne Frequency Meter and Calibrator | 178 |
| V-5 | Ganged Variacs | 22 | 631-B | Strobotac | 2 |
| V-10 | Variac | 18 | 631-P1 | Strobotron | 3 |
| V-10 | Ganged Variacs | 22 | 648-A | Strobolux | 4 |
| V-20 | Variac | 18 | 650-A | Impedance Bridge | 76 |
| V-20 | Ganged Variacs | 22 | 650-P1 | Oscillator-Amplifier | 78 |
| 50 | Variac | 18 | 651-AE | Oscillograph Recorder | 136 |
| 50 | Ganged Variacs | 22 | 651-AG | Camera | 6 |
| 50-P1 | Choke | 22 | 654-A | Decade Voltage Divider | 33 |
| 106 | Standard Inductance | 60 | 663 | Resistor | 36 |
| 107 | Variable Inductor | 58 | 667-A | Inductance Bridge | 79 |
| 119 | Radio-Frequency Choke | 210 | 668 | Compensated Decade-Resistance Unit | 31 |
| 200-B | Variac | 18 | 670-F | Compensated Decade Resistor | 30 |
| 214-A | Rheostat and Voltage Divider | 38 | 674 | Plugs and Jacks | 208 |
| 219 | Decade Condenser | 53 | 700-A | Wide-Range Beat-Frequency Oscillator | 116 |
| 274 | Plugs and Jacks | 207 | 700-P1 | Voltage Divider | 117 |
| 274 | Shielded Plugs and Cables | 208 | 707-A | Cathode-Ray Null Detector | 95 |
| 301-A | Rheostat and Voltage Divider | 38 | 707-P | Tuning and Phasing Units | 96 |
| 314-A | Rheostat and Voltage Divider | 38 | 715-A | Direct-Current Amplifier | 98 |
| 318-B | Dial Plate | 199 | 716-C | Capacitance Bridge | 70 |
| 371 | Rheostat and Voltage Divider | 38 | 720-A | Heterodyne Frequency Meter | 180 |
| 380 | Decade-Capacitor Unit | 54 | 722 | Precision Condenser | 44-46 |
| 471-A | Rheostat and Voltage Divider | 38 | 723 | Vacuum-Tube Fork | 126 |
| 483-F | Output Meter | 153 | 723-P | Power Supply | 127 |
| 500 | Resistor | 37 | 724-B | Precision Wavemeter | 194 |
| 505 | Capacitor | 51 | 726-P1 | Multiplier | 148 |
| 509 | Standard Condenser | 49 | 727-A | Vacuum-Tube Voltmeter | 148 |
| 510 | Decade-Resistance Unit | 28 | 728-A | D-C Vacuum-Tube Voltmeter | 150 |
| 520-A | Dial Lock | 199 | 729-A | Megohmmeter | 151 |
| 522-A | Dial Plate | 199 | 736-A | Wave Analyzer | 130 |
| 530-A | Band-Pass Filter | 140 | 740-B | Capacitance Test Bridge | 82 |
| 544-B | Megohm Bridge | 88 | 758-A | Wavemeter | 195 |
| 546-C | Microvolter | 158 | 759-B | Sound-Level Meter | 10 |
| 549 | Contactator | 5 | 759-P21 | Extension Cable and Tripod | 11 |
| 561-D | Vacuum-Tube Bridge | 86 | 759-P35 | Vibration Pickup | 12 |
| 566-A | Wavemeter | 193 | | | |
| 572-B | Microphone Hummer | 128 | | | |
| 578 | Shielded Transformer | 80 | | | |



INDEX BY TYPE NUMBER (continued)

| <i>Type</i> | <i>Name</i> | <i>Page</i> | <i>Type</i> | <i>Name</i> | <i>Page</i> |
|-------------|--|-------------|-------------|---|-------------|
| 759-P36 | Control Box | 12 | 1108-A | Coupling Panel | 175 |
| 760-A | Sound Analyzer | 13 | 1109-A | Comparison Oscilloscope | 174 |
| 761-A | Vibration Meter | 15 | 1110-A | Interpolating Frequency Standard | 176 |
| 762-B | Vibration Analyzer | 17 | 1110-P1 | Multivibrator | 176 |
| 774 | Coaxial Connectors (Terminals) . | 204 | 1140-A | U-H-F Wavemeter | 196 |
| 783-A | Output-Power Meter | 155 | 1141-A | Audio-Frequency Meter | 190 |
| 805-C | Standard-Signal Generator | 110 | 1170-A | F-M Monitor | 184 |
| 813-A | Audio Oscillator | 127 | 1175-B | Frequency Monitor | 186 |
| 815 | Precision Fork | 191 | 1175-BT | Frequency Monitor | 186 |
| 816 | Vacuum-Tube Precision Fork | 192 | 1176-A | Frequency Meter | 188 |
| 821-A | Twin-T Impedance-Measuring Circuit | 72 | 1181-A | Frequency Deviation Monitor | 182 |
| 829 | Decade Attenuator Unit | 34 | 1205-A | Unit Power Supply | 105 |
| 830 | Wave Filters | 138 | 1206-A | Unit Amplifier | 105 |
| 846 | Variable Air Capacitor | 48 | 1207-A | Unit Oscillator | 106 |
| 847 | Variable Air Capacitor | 48 | 1207-P | Coils and Tuning Units | 106 |
| 848 | Variable Air Capacitor | 47 | 1231-B | Amplifier and Null Detector | 100 |
| 857-A | U-H-F Oscillator | 122 | 1231-P | Tuned Circuit | 101 |
| 869-A | Pulse Generator | 124 | 1260-A | Variac-Rectifier | 104 |
| 874 | Coaxial Connectors (Terminals) . | 203 | 1261-A | Power Supply | 102 |
| 901 | Direct-Drive Dial | 200 | 1301-A | Low-Distortion Oscillator | 118 |
| 902 | Direct- and Friction-Drive Dial | 200 | 1301-P1 | Range Extension Unit | 118 |
| 904 | Direct- and Friction-Drive Dial | 200 | 1302-A | Oscillator | 120 |
| 905 | Precision Dial | 200 | 1450 | Decade Attenuator | 34 |
| 906 | Precision Dial | 200 | 1490 | Decade Inductor | 57 |
| 907 | Gear-Drive Precision Dial | 198 | 1500-A | Counting-Rate Meter | 156 |
| 913-C | Beat-Frequency Oscillator | 114 | 1500-P | Counter Tubes | 157 |
| 916-A | Radio-Frequency Bridge | 74 | 1530-A | Microflash | 8 |
| 920 | Switch | 209 | 1533-A | High-Speed Motion-Picture Assembly | 7 |
| 938 | Binding Posts and Insulators | 206 | 1611-A | Capacitance Test Bridge | 84 |
| 940 | Decade-Inductor Unit | 56 | 1612-A | R-F Capacitance Meter | 92 |
| 1001-A | Standard-Signal Generator | 112 | 1614-A | Capacitance Bridge | 90 |
| 1100-A | Frequency Standard | 164 | 1631-A | Inductance Bridge | 91 |
| 1101-A | Piezo-Electric Oscillator | 165 | 1670-A | Magnetic Test Set | 93 |
| 1102-A | Multivibrator and Power Supply Unit | 165 | 1800-A | Vacuum-Tube Voltmeter | 146 |
| 1103-A | Synchrometer | 165 | 1800-P2 | Multiplier | 148 |
| 1105-A | Frequency Measuring Equipment | 167 | 1802-A | Crystal Galvanometer | 144 |
| 1106 | Frequency Transfer Unit | 170 | 1861-A | Megohmmeter | 152 |
| 1107-A | Interpolation Oscillator | 172 | 1931-A | Modulation Monitor | 132 |
| | | | 1932-A | Distortion and Noise Meter | 134 |



INDEX BY TITLE

| | <i>Page</i> | | <i>Page</i> |
|---|--|--|---------------|
| Adjustable transformer (Variac) | 18-22 | Cathode-ray null detector | 95 |
| Air capacitors | 44-49 | Choke (for Variacs) | 22 |
| Amplifiers | 78, 95, 98, 100, 105 | Choke, radio-frequency | 210 |
| Amplifier, bridge | 78, 95, 100 | Coaxial connectors | 203-205 |
| direct-current | 98 | Comparison oscilloscope | 174 |
| unit | 105 | Compensated decade-resistance unit. | 31 |
| Amplifier and null detector | 100 | Compensated decade resistor | 30 |
| Amplifier-oscillator | 78 | Condensers (see Capacitors) | 41-55 |
| Analyzer, noise | 13 | Connectors, coaxial | 203-205 |
| sound | 13 | shielded | 203-205, 208 |
| vibration | 17 | Constant-inductance resistors | 30, 31 |
| wave | 13, 17, 130 | Contactor, hand | 5 |
| Attenuator, decade | 34, 35 | stroboscope | 5 |
| Audio-frequency meter | 188-190 | Control box and vibration pickup | 12 |
| Audio-frequency oscillator | 78, 106, 114-121, 126-128, 172, 191, 192 | Copper-oxide rectifier voltmeter | 153 |
| Autotransformer (Variac) | 18-22 | Cord, patch | 203-205 |
| Band-pass filter | 101, 138, 140 | power | 210 |
| Bar knobs | 202 | Counter tubes | 157 |
| Beat-frequency oscillators | 114-117, 172 | Counting-rate meter | 156 |
| Beat-frequency oscillator, wide-range | 116 | Coupling panel | 175 |
| Binding posts and assemblies | 206 | Crystal galvanometer (voltmeter) | 144 |
| Bridges | 61-96 | Decade attenuator | 34, 35 |
| Bridge, capacitance | 70-77, 82-85, 90, 92 | Decade capacitor unit | 54 |
| capacitance test | 82-85 | Decade condenser | 53 |
| high-resistance | 88 | Decade resistance box | 26, 30 |
| impedance | 76 | Decade resistance unit | 28 |
| inductance | 76, 79, 91 | Decade resistance unit, compensated | 31 |
| megohm | 88 | Decade switches | 29, 55, 209 |
| power-factor | 70, 76, 82-85, 90 | Decade voltage divider | 33 |
| radio-frequency | 72-75, 92 | Detector, heterodyne | 170 |
| resistance | 74, 76, 88 | Dial, direct-drive | 200 |
| Schering | 70 | friction-drive | 200 |
| vacuum-tube | 86 | gear-drive | 198 |
| Bridge amplifier | 78, 95, 100 | precision | 198, 200 |
| Bridge amplifier-oscillator | 78 | Dial lock | 199 |
| Bridge transformer | 80 | Dial plate | 199 |
| Broadcast frequency monitor | 182 | Direct-current amplifier | 98 |
| Broadcast monitor, F-M | 184 | Direct-current vacuum-tube voltmeter | 150 |
| Cable, extension, and tripod | 11 | Distortion and noise meter | 134 |
| shielded | 203-205, 208 | F-M monitor | 184 |
| Cable jack | 203-205 | Filter, band-pass | 101, 138, 140 |
| Cable plug | 203-205 | high-pass | 138 |
| Calibrator, piezo-electric | 178 | low-pass | 138 |
| Camera, continuous-film stroboscope | 6 | wave | 101, 138, 140 |
| Capacitance bridge | 70-77, 82-85, 90, 92 | Fixed capacitor | 49-51 |
| Capacitance test bridge | 82-85 | Fixed inductor | 60, 210 |
| Capacitors | 41-55 | Fixed resistor | 36, 37 |
| Capacitor, air dielectric | 44-49 | Flash, high-speed | 8 |
| decade | 53, 54 | Fluted knobs | 202 |
| fixed | 49-51 | Fork, precision | 191, 192 |
| mica dielectric | 49, 51, 53, 54 | vacuum-tube driven | 126, 192 |
| paper dielectric | 53, 54 | Frequency deviation monitor | 182 |
| precision | 44-46 | Frequency measuring equipment. | 159-196 |
| standard | 44-46, 49 | Frequency meter, audio | 188-190 |
| variable air | 44-49 | heterodyne | 170, 178, 180 |



INDEX BY TITLE (continued)

| | <i>Page</i> | | <i>Page</i> |
|---|-------------------|--|---|
| Frequency monitor | 182-189 | Megohmmeter | 151, 152 |
| Frequency standard | 164-166, 176 | Meters | 141-158 |
| Frequency transfer unit | 170 | Meter, alternating-current | 144-149, 153-155, 158 |
| Friction-drive dial | 200 | audio-frequency | 188-190 |
| Galvanometer, crystal | 144 | battery-operated | 144, 148-151 |
| Ganged Variacs | 22 | counting-rate | 156 |
| Gear-drive dial | 198 | distortion and noise | 134 |
| Geiger-Mueller counter | 156 | frequency deviation | 182-189 |
| Generator, pulse | 124 | heterodyne frequency | 170, 178, 180 |
| standard-signal | 110-113 | megohm | 151, 152 |
| Hand contactor | 5 | noise | 10 |
| Harmonic analyzer | 13, 17, 130 | output | 153 |
| Heterodyne detector | 170 | output-power | 154, 155 |
| Heterodyne frequency meter | 170, 178, 180 | r-f capacitance | 92 |
| High-frequency resistor | 36 | sound-level | 10 |
| High-pass filter | 138 | vibration | 15 |
| High-speed light source | 8 | Microflash | 8 |
| High-speed motion picture assembly | 7 | Microphone hummer | 128 |
| High-speed recorder | 6, 136 | Microvolter, audio-frequency | 158 |
| Hummer, microphone | 128 | Modulation monitor | 132 |
| Impedance bridge | 76 | Monitor, frequency | 182-189 |
| Impedance-measuring network, Twin-T | 72 | Motion-picture assembly | 7 |
| Inductance bridge | 76, 79, 91 | Multiplier (for vacuum-tube voltmeter) | 148 |
| Inductance standard | 60 | Multivibrators | 165, 176 |
| Inductors | 56-60, 210 | Mutual inductance standard | 58 |
| Inductor, decade | 56, 57 | Network, attenuation | 34, 35 |
| fixed | 60, 210 | Noise meter | 10, 134 |
| standard | 60 | Null detector, and amplifier | 100 |
| variable | 56-59 | cathode-ray | 95 |
| Industrial instruments | 1-22 | Oscillators | 78, 106, 110-128, 165, 172, 176, 191, 192 |
| Insertion unit, coaxial | 204 | Oscillator, audio | 78, 106, 114-121, 126-128, 172, 191, 192 |
| Insulated plugs | 207 | beat-frequency | 114, 116, 172 |
| Insulators, panel terminal | 206 | electro-mechanical | 126-128, 191, 192 |
| Interpolating frequency standard | 176 | interpolation | 172 |
| Interpolation equipment | 167-176 | inverse feedback | 118-121 |
| Interpolation oscillator | 172 | piezo-electric | 165, 176 |
| Inverse-feedback oscillator | 118-121 | radio-frequency | 106, 110-113, 116, 122 |
| Jack connector, coaxial | 203-205 | resistance-capacitance-tuned | 118-121 |
| Jacks and plugs | 203, 204, 206-208 | tuning-fork-driven | 126, 127, 191, 192 |
| Jumbo jacks | 208 | ultra-high frequency | 122 |
| Jumbo plugs | 208 | unit | 106 |
| Knobs | 202 | Oscillator-amplifier | 78 |
| Knob, bar | 202 | Oscillograph recorder | 136 |
| fluted | 202 | Oscilloscope, comparison | 174 |
| spinner | 202 | Output meter | 153 |
| switch | 202 | Output-power meter | 154, 155 |
| Lock, dial | 199 | Panel jack, coaxial | 203-205 |
| Losses in capacitors | 42 | Panel plug, coaxial | 203-205 |
| Low-distortion oscillator | 118 | Panel terminal insulators | 206 |
| Low-pass filter | 138 | Parts and accessories | 197-210 |
| Magnetic test set | 93 | Patch cord | 203-205 |
| Megohm bridge | 88 | Pickup, vibration | 12 |
| | | Piezo-electric oscillator | 165, 176 |



INDEX BY TITLE (continued)

| | <i>Page</i> |
|---|------------------------|
| Plate, dial | 199 |
| Plug connector, coaxial | 203-205 |
| Plugs and jacks | 203, 204, 207, 208 |
| Power cord | 210 |
| Power meter, output | 154, 155 |
| Power stroboscope | 7 |
| Power supply | 102-105 |
| Precision condenser | 44-46 |
| Precision dial | 198, 200 |
| Precision fork | 191, 192 |
| Precision wavemeter | 194 |
| Primary frequency standard | 164-166 |
| Pulse generator | 124 |
| | |
| Radio-frequency bridge | 72-75 |
| Radio-frequency capacitance meter | 92 |
| Radio-frequency choke | 210 |
| Radio-frequency oscillator | 106, 110-113, 116, 122 |
| Range-extension unit | 118 |
| Recorder, oscillograph | 136 |
| stroboscopic | 6 |
| Resistance, compensated decade | 30, 31 |
| decade | 26-32 |
| Resistance bridge | 74, 76, 88 |
| Resistance meter | 151, 152 |
| Resistance-capacitance-tuned oscillator | 118-121 |
| Resistors | 23-40 |
| Resistor, compensated decade | 30, 31 |
| constant-inductance | 30, 31 |
| decade | 26-32 |
| fixed | 36, 37 |
| high-frequency | 36 |
| variable | 26-32, 38-40 |
| Rheostat and voltage divider | 38-40 |
| | |
| Schering bridge | 70 |
| Secondary frequency standard | 164-166 |
| Shielded conductors | 203-205, 208 |
| Shielded plug and cable | 203-205, 208 |
| Shielded transformer | 80 |
| Signal generator, standard | 110-113 |
| Sound analyzer | 13 |
| Sound-level meter | 10 |
| Spinner knob | 202 |
| Standard, inductance | 60 |
| interpolating frequency | 176 |
| mutual inductance | 58 |
| primary frequency | 164-166 |
| secondary frequency | 164-166 |
| Standard condenser | 44-46, 49 |
| Standard-signal generator | 110-113 |
| Strobolux | 4 |
| Stroboscope | 2-9 |
| Stroboscope contactor | 5 |
| Stroboscope recorder | 6 |
| | |
| Strobotac | 2 |
| Strobotron | 3 |
| Switch knob | 202 |
| Switches | 29, 55, 209 |
| Synchronous-motor contactor | 5 |
| Synchrometer | 165 |
| | |
| Television frequency monitor | 186 |
| Temperature-control box | 165 |
| Terminal insulators, panel | 206 |
| Terminal unit, coaxial | 203-205 |
| Test bridge, capacitance | 82-85 |
| Test set, magnetic | 93 |
| Transfer unit, frequency | 170 |
| Transformer, adjustable (Variac) | 18-22 |
| bridge | 80 |
| shielded | 80 |
| Tripod and extension cable | 11 |
| Tuned circuit | 101 |
| Tuning fork, precision | 191, 192 |
| vacuum-tube driven | 126, 192 |
| Tuning-fork oscillators | 126, 127, 191, 192 |
| Twin-T impedance-measuring network | 72 |
| | |
| U-H-F heterodyne frequency meter | 180 |
| U-H-F oscillator | 122 |
| U-H-F wavemeter | 195, 196 |
| Unit instruments | 105, 106 |
| | |
| Vacuum-tube bridge | 86 |
| Vacuum-tube driven fork | 126, 192 |
| Vacuum-tube voltmeter | 144-150 |
| Vacuum-tube voltmeter, d-c | 150 |
| Variable air capacitor | 44-49 |
| Variable inductor | 56-59 |
| Variable resistor | 26-32, 38-40 |
| Variac | 18-22 |
| Variac rectifier | 104 |
| Variometer | 58 |
| Vibration analyzer | 17 |
| Vibration meter | 15 |
| Vibration pickup | 12 |
| Voltage divider (decade) | 33 |
| Voltage divider (rheostat) | 38-40 |
| Voltmeter, crystal | 144 |
| oxide-rectifier | 153 |
| vacuum-tube | 144-150 |
| | |
| Wave analyzer | 13, 17, 130 |
| Wave filter | 101, 138, 140 |
| Waveform-measuring instruments | 13, 17, 130, 134 |
| Wavemeters (see Frequency meter, heterodyne) | 193-196 |
| Wavemeter, precision | 194 |
| Wide-range beat-frequency oscillator | 116 |



FOREIGN DISTRIBUTORS

AUSTRALIA

HAYWARD C. PARISH
Box 2148 G.P.O.
Sydney, Australia
WARBURTON FRANKI, LIMITED
380 Bourke Street
Melbourne, Australia

BELGIUM

A. A. POSTHUMUS
Vondellaan 15 & 17
Baarn, Holland

BRITISH ISLES

CLAUDE LYONS, LIMITED
76 Old Hall Street
Liverpool, England
CLAUDE LYONS, LIMITED
180-182A Tottenham, Court Road
London W. 1, England

CANADA

CANADIAN MARCONI COMPANY
P.O. Box 1690
Montreal, Quebec, Canada

CHINA

CHINA SCIENTIFIC INSTRUMENT COMPANY
131 Museum Road
Shanghai, China

CZECHOSLOVAKIA

ELFLOMETA COMPANY, LTD.
Palackeho 42
Praha XVI, Czechoslovakia

EGYPT

THEODORE T. CASDAGLI & CO., LTD.
16, Sharia Sheikh Hamza
P.O. Box 885
Cairo, Egypt

FINLAND

K. L. NYMAN
9 Meritullinkata
Helsingfors, Finland

FRANCE

RADIOPHON
50, Rue du Faubourg Poissonniere
Paris 10, France

HOLLAND

A. A. POSTHUMUS
Vondellaan 15 & 17
Baarn, Holland

INDIA

EASTERN ELECTRIC & ENGINEERING CO.
129 Mahatma Gandhi Road
P.O. Box 459
Bombay, India

ITALY

ING. S. BELOTTI & CO.
Piazza Trento, 8
Milan (VII), Italy

NEW ZEALAND

HAYWARD C. PARISH
Box 2148 G.P.O.
Sydney, Australia
SPEDDING, LIMITED
Cor. Beach Road & Anzac Avenue
Auckland, C.1, New Zealand

NORWAY

MASKIN-AKTIESELSKAPET ZETA
Drummensveien 26
Oslo 22, Norway

SOUTH AFRICA

BARTLE AND COMPANY
Post Office Box 2466
Johannesburg, South Africa

SOUTH AMERICA

AD. AURIEMA, INC.
89 Broad Street
New York 4, New York

SPAIN

AD. AURIEMA, INC.
89 Broad Street
New York 4, New York

SWEDEN

JOHN C. LAGERCRANTZ
Vartavagen 57
Stockholm, Sweden

SWITZERLAND

SEYFFER AND COMPANY
Kanzleistrasse 126
Zurich, Switzerland

TURKEY

ETABLISSEMENT MEHMET VASFI
Boite Postale Istanbul 143
Istanbul, Turkey



QUICK INDEX

| | | |
|-----|-------|--|
| iv | | HOW TO ORDER |
| 2 | | INDUSTRIAL INSTRUMENTS |
| 24 | | RESISTORS |
| 42 | | CAPACITORS |
| 56 | | INDUCTORS |
| 62 | | BRIDGES AND ACCESSORIES |
| 98 | | AMPLIFIERS AND POWER SUPPLIES |
| 108 | | OSCILLATORS AND STANDARD-SIGNAL GENERATORS |
| 130 | | WAVEFORM-MEASURING INSTRUMENTS |
| 142 | | METERS |
| 160 | | FREQUENCY-MEASURING EQUIPMENT |
| 198 | | PARTS AND ACCESSORIES |
| 212 | | REACTANCE CHARTS |
| 216 | | DECIBEL TABLES |
| 222 | | INDEX BY TYPE NUMBER |
| 224 | | INDEX BY TITLE |





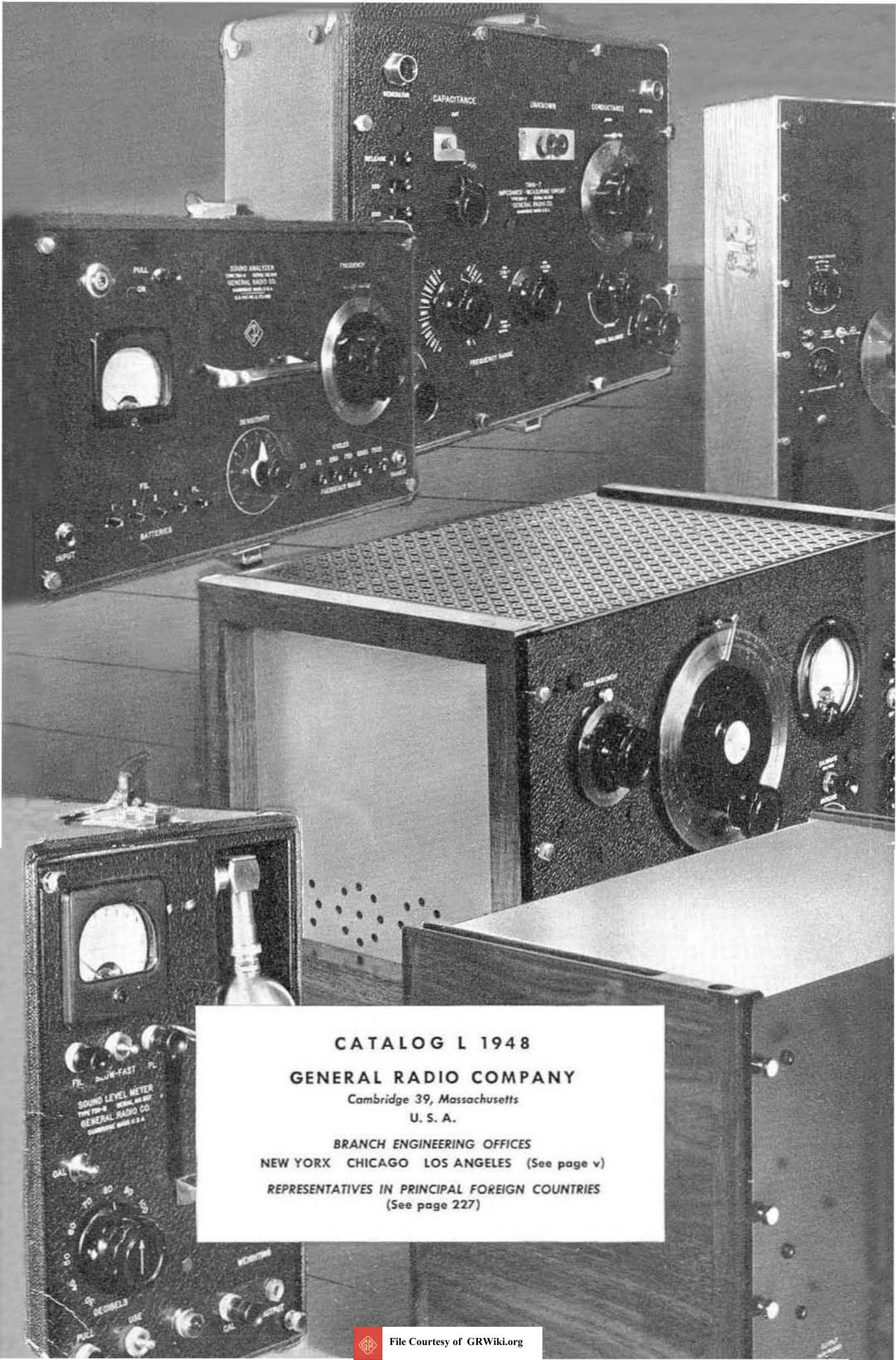

CATALOG L 1948

GENERAL RADIO COMPANY

Cambridge 39, Massachusetts

U. S. A.

BRANCH ENGINEERING OFFICES

NEW YORK CHICAGO LOS ANGELES (See page v)

REPRESENTATIVES IN PRINCIPAL FOREIGN COUNTRIES
(See page 227)

