

**OPERATING INSTRUCTIONS**



**TYPE 1213-D**

**UNIT TIME/FREQUENCY  
CALIBRATOR**

**G E N E R A L R A D I O C O M P A N Y**

Corrections for Operating Instructions

Type 1213-D Unit Time/Frequency Calibrator

Page 13, paragraph 4.2.3.2c, line 5: Change "90 kc" to "85 kc".

Page 17, paragraph 4.3.10, line 4: Change "D101" to "D103".

Page 19, Figure 7, 1-Mc Multivibrator-Triggered, b:

0.2  $\mu$ sec/cm; 10.0 volts/cm. TP3.

GENERAL RADIO COMPANY  
West Concord, Massachusetts

Printed in U.S.A.

Form 786-F



# OPERATING INSTRUCTIONS

## TYPE **1213-D**

---

# UNIT TIME/FREQUENCY CALIBRATOR



Form 786-F  
October, 1959

GENERAL RADIO COMPANY  
WEST CONCORD, MASSACHUSETTS, USA



# CONDENSED OPERATING INSTRUCTIONS

The standard frequencies of the Type 1213-D can be used in any of these ways:

- 1 - directly at high level.
- 2 - as a harmonic spectrum fed from the RF OUTPUT HARMONIC SERIES connector.
- 3 - as a beat-frequency detector and amplifier for calibrating externally generated signals mixed with standard-frequency spectrum.

## 1 - DIRECT OPERATION ON FUNDAMENTALS

- a. Turn power supply on and let instrument warm up.
- b. Set AUDIO BEAT SIGNAL-TIMING MARKERS switch to TIMING MARKERS.
- c. Connect system or indicator to OUTPUT terminals.
- d. Set FUNDAMENTAL FREQUENCY switch to STANDBY, then to desired frequency.

## 2 - HARMONIC SPECTRUM

- a. Turn power supply on and let instrument warm up.
- b. Set AUDIO BEAT SIGNAL-TIMING MARKERS switch to AUDIO BEAT SIGNAL.
- c. Connect external system to RF OUTPUT HARMONIC SERIES connector.
- d. Set FUNDAMENTAL FREQUENCY switch to STANDBY, then to desired frequency.

## 3 - FREQUENCY CALIBRATION

- a. Turn power supply on and let instrument warm up.
- b. Set AUDIO BEAT SIGNAL-TIMING MARKERS switch to AUDIO BEAT SIGNAL.
- c. Apply signal to be calibrated at RF INPUT TO DETECTOR connector.
- d. Set AUDIO GAIN control fully clockwise.
- e. Connect earphones (or other suitable detector) to OUTPUT terminals.
- f. Set FUNDAMENTAL FREQUENCY switch to STANDBY, then to desired frequency.
- g. Vary externally applied frequency slowly to produce audible beats with harmonic spectrum.

**NOTE:** To obtain standard frequencies from the Type 1213-D, be sure to set the FUNDAMENTAL FREQUENCY switch first to STANDBY, then to a frequency setting, in order to start the dividers.



## SPECIAL REQUEST TO THE USER OF THIS INSTRUMENT

We believe that the most effective way to make our products more useful is to learn from the experience and opinions of those who use them. For this reason we have included a questionnaire at the rear of this manual. Your answers to the questions contained, based on your experience in using this instrument, will be of great value to General Radio engineers and other personnel concerned with new products. Such comments will have a strong influence on the direction of future development work. The resulting better products will benefit our customers as well as ourselves.

The questionnaire sheet is its own postage-paid envelope. Simply cut it out, fold as directed, staple, and mail.

Any information you supply will not go outside our company without your specific authorization. May we have your opinions?



# TABLE OF CONTENTS

	Page
Section 1 INTRODUCTION . . . . .	1
1.1 Purpose . . . . .	1
1.2 Description . . . . .	1
1.3 Auxiliary Equipment . . . . .	3
Section 2 PRINCIPLES OF OPERATION . . . . .	3
2.1 Oscillator and Buffer Circuits . . . . .	3
2.2 Multivibrators . . . . .	5
2.3 Harmonic Generator and Mixer Circuit . . . . .	6
2.4 Audio-Video Amplifier . . . . .	6
Section 3 OPERATING PROCEDURE . . . . .	7
3.1 General . . . . .	7
3.2 Calibration by a Primary Frequency Standard . . . . .	7
3.3 Oscilloscope Calibration . . . . .	8
3.4 Variable-Frequency-Oscillator Calibration by Type 1213-D Internal Mixer-Amplifier System . . . . .	8
3.5 Setting Fixed-Frequency Oscillators Exactly to a Harmonic of the Type 1213-D . . . . .	9
3.6 Calibration by Means of the Output Harmonic Series of the Type 1213-D . . . . .	10
3.7 Interpolation Method of Calibration . . . . .	11
Section 4 CALIBRATION, SERVICE AND MAINTENANCE . . . . .	12
4.1 General . . . . .	12
4.2 Circuit Adjustments . . . . .	12
4.3 Trouble-Shooting Procedure . . . . .	14
TABLE OF VOLTAGES AND RESISTANCES . . . . .	20
PARTS LIST . . . . .	21
SCHEMATIC DIAGRAM OF TYPE 1213-D. . . . .	23



## SPECIFICATIONS

**Output Frequencies:** 10 Mc, 1 Mc, 100 kc, 10 kc.

**Output Amplitudes:** 10 Mc: 5 v peak-to-peak; 30 v peak-to-peak at lower output frequencies from pulse amplifier; rf harmonics usable to 1000 Mc from 10-Mc output, to 500 Mc from 1-Mc output, to 100 Mc from 100-kc output, and to 10 Mc from 10-kc output.

**Output Impedance:** Video cathode-follower, 300 ohms; rf output obtained from crystal-diode harmonic generator.

### Frequency Stability:

#### 1. Temperature

##### a. Warm-up Characteristics:

For ambient temperatures of 25°C, or over, the warm-up drift will not exceed  $-2 \times 10^{-7}/^{\circ}\text{C}$ . With ambient 0–10°C crystal may not operate until instrument attains operating temperature. Minimum operating ambient 0°C.

##### b. Operating Characteristics:

In ambient range 20–40°C, the oscillator drift is between  $-1 \times 10^{-7}/^{\circ}\text{C}$  and  $+2 \times 10^{-7}/^{\circ}\text{C}$ .

#### 2. Line Voltage Effects

Momentary line voltage changes of  $\pm 10\%$  affect frequency by less than  $5 \times 10^{-8}$ . Changing line voltage will affect frequency per

temperature specification above. ( $\pm 10\%$  line will change temperature  $\pm 4^{\circ}\text{C}$ .)

### 3. Switching and Loading Effects

The combined effects of switching and loading due to external connections are less than  $1 \times 10^{-7}$ .

**Sensitivity:** Usable beat notes can be produced with 50 millivolts signal input to mixer over the harmonic ranges specified above under "Output amplitudes."

**Tubes:** One each 6AK5, 6AH6WA, 6922, 6AN8, 6U8, 5651; two 5964.

**Power Required:** 6.3 v ac, 3 amp; 300 v dc, 60 ma. TYPE 1203-B Unit Power Supply is recommended.

**Accessories Supplied:** TYPE 1213-P1 Differentiator, TYPE 874 Coaxial Connector, and multi-point connector.

**Mounting:** Aluminum panel and sides finished in gray; aluminum cover finished in clear lacquer. Relay rack panel (TYPE 480-P4U3) is available for mounting both calibrator and power supply.

**Dimensions:** Width 10½, height 5¾, depth 7 in., over-all.

**Weight:** 4 lb., 10 oz.

\*U. S. Patent 2,548,457; licensed under patents of the American Telephone and Telegraph Co., of Radio Corporation of America, and of G. W. Pierce (pertaining to piezo electric crystals and associated circuits).

*General Radio Experimenter* reference: Vol 33, No. 10, October, 1959



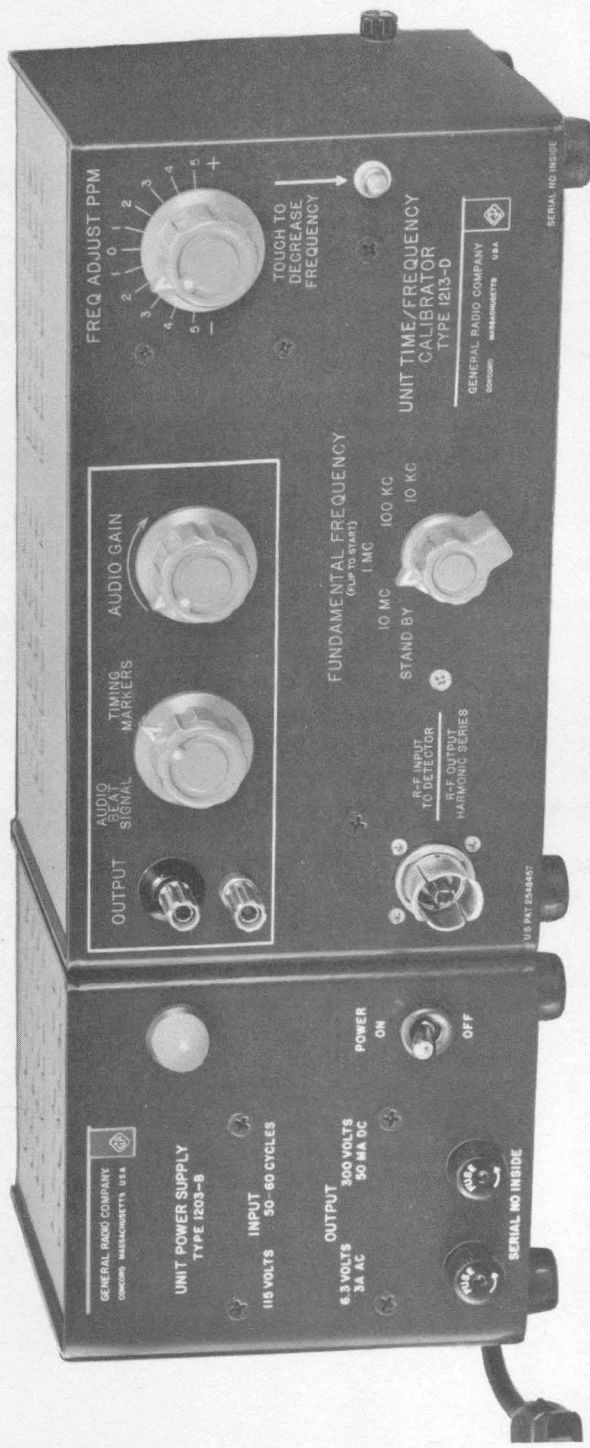

Figure 1. Type 1213-D Unit Time/Frequency Calibrator with Type 1203-B Unit Power Supply.



# TYPE 1213-D

## UNIT TIME/FREQUENCY CALIBRATOR

### Section 1 INTRODUCTION

**1.1 PURPOSE.** The Type 1213-D Unit Time/Frequency Calibrator (Figure 1) comprises, in a small, unit-type case, a stable secondary frequency-time standard useful in the frequency calibration of oscillators, receivers, and other wide-range devices at frequencies up to 1000 Mc. It can also be used for the sweep-time calibration of oscilloscopes at intervals from 0.1 to 100 microseconds.

#### 1.2 DESCRIPTION.

**1.2.1 GENERAL.** The basic circuits, shown in Figure 2, are:

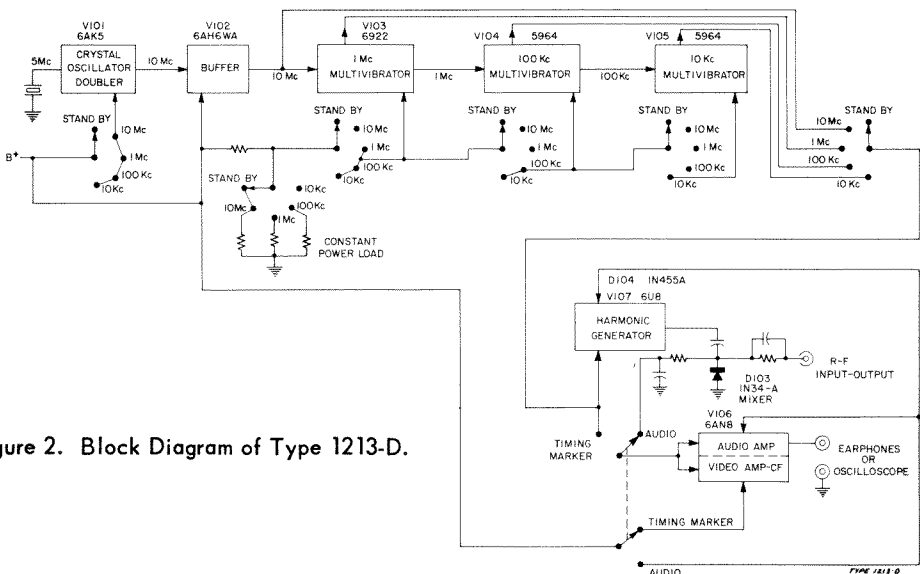

Figure 2. Block Diagram of Type 1213-D.

## GENERAL RADIO COMPANY

- a. a 5-Mc crystal-controlled oscillator-doubler,
- b. a 10-Mc buffer stage,
- c. three multivibrators, controlled by a panel switch, dividing the 10-Mc crystal-controlled frequency by factors of 10, 100, and 1000,
- d. a harmonic generator that produces a continuous harmonic spectrum of the 10-Mc, 1-Mc, 100-kc, and 10-kc signals,
- e. a crystal mixer to couple the harmonics out of the instrument through a coaxial lead or to detect a beat against another input signal,
- f. an amplifier stage to amplify the beat signal from the mixer to drive earphones or to produce video signals for oscilloscope calibration.

The FUNDAMENTAL FREQUENCY and AUDIO BEAT SIGNAL-TIMING MARKERS switches connect various circuit combinations to produce desired output frequencies and specialized amplifier characteristics. Power input to the unit is kept nearly constant by dummy load resistors so that the heating is uniform, and switching operations have little effect on the standard frequency.

1.2.2 CONTROLS. The following controls are on the panel of the Type 1213-D Unit Time/Frequency Calibrator:

<u>Name</u>	<u>Description</u>	<u>Function</u>
AUDIO BEAT SIGNAL-TIMING MARKERS	2-position selector switch	Provides for audio amplification of beat note from mixer, or timing markers for oscilloscope calibration from same stages.
AUDIO GAIN	Continuous rotary control	Varies amplifier gain with mode switch in AUDIO BEAT SIGNAL position.
FREQUENCY ADJUST	Continuous rotary control	Sets output frequency and fundamental component of standard rf spectrum.
FUNDAMENTAL FREQUENCY	5-position selector switch	Sets output frequency and fundamental component of standard rf spectrum.
TOUCH TO DECREASE FREQUENCY	Touch button	Momentarily changes standard frequency without disturbing crystal oscillator center frequency.

1.2.3 CONNECTORS. The following connectors are on the Type 1213-D Unit Time/Frequency Calibrator:

## TYPE 1213-D UNIT/TIME FREQUENCY CALIBRATOR

<u>Name</u>	<u>Description</u>	<u>Function</u>
OUTPUT	Jack-top binding posts (2)	Audiobeat note from internal mixer or timing markers for oscilloscope calibration.
RF INPUT TO DETECTOR RF HARMONIC SERIES	Type 874 Coaxial Connector	Input for rf to be calibrated or output for rf standard harmonics.
Power	Multipoint male connector	Power supply connections.

1.3 AUXILIARY EQUIPMENT. An external source of 300-volt power and a 6.3-volt heater supply are necessary. Either the Type 1201 or Type 1203 Unit Power Supply is satisfactory. The Type 1201, a regulated power supply, is recommended for a slight increase in crystal frequency stability in the face of varying line voltage, and 120-cycle hum is materially reduced in the audio amplifier. The Unit Power Supply plugs directly into the mating Jones socket on the left-hand side of the Unit Time/Frequency Calibrator.

For power supplies other than General Radio Unit Types, the requirements are 300 volts at 60 ma and 6.3 volts at 3 amperes. A multipoint connector is supplied to adapt the power supply to the power connector on the Type 1213-D. On this connector, terminal 15 is for B+, terminal 13 for the heater supply, and terminals 14 and 16 ground.

## Section 2 PRINCIPLES OF OPERATION

2.1 OSCILLATOR AND BUFFER CIRCUITS (see Figure 8). The 5-Mc crystal, X101, controls the frequency of a triode oscillator formed by the screen grid, control grid, and cathode of V101. C104 is an internal, coarse frequency adjustment; C101, the FREQUENCY ADJUST panel control, is a fine frequency adjustment. The calibration of C101 is accurate to approximately one-half part per million. The plate circuit of the oscillator (L101, C109) is tuned to 10 Mc and selects the second harmonic.

The frequency stability characteristics of the oscillator are determined chiefly by the characteristics of the quartz crystal. No tempera-

## GENERAL RADIO COMPANY

ture control is provided, hence particular attention has been paid to the design of the crystal with respect to its temperature characteristics. When the instrument has reached thermal equilibrium (after approximately one hour), the crystal temperature is about  $20^{\circ}\text{C}$  above the ambient temperature. The crystal is designed so that its smallest frequency excursion occurs over the temperature range from  $20^{\circ}\text{C}$  to  $60^{\circ}\text{C}$ , with a zero temperature coefficient at approximately  $45^{\circ}\text{C}$  (see Figure 3). Therefore, at normal room temperature ( $25^{\circ}\text{C}$ ) the crystal operates near its point of zero temperature coefficient.

The frequency-versus-temperature characteristic for a typical crystal is shown by the solid line curve of Figure 3. The two broken lines represent the maximum possible deviation from the ideal characteristic due to manufacturing tolerances. Note that for  $45^{\circ}\text{C}$  at the two extremes of the tolerance, the temperature coefficient does not exceed  $1 \times 10^{-7}$  per degree centigrade; under laboratory conditions, a minute-to-minute stability of better than  $1 \times 10^{-7}$  can be expected.

If the temperature at the crystal is below  $20^{\circ}\text{C}$ , it may not oscillate; but after the instrument has reached thermal equilibrium, the crystal will have risen by about  $20^{\circ}\text{C}$  above the ambient temperature. Therefore, the instrument can be operated down to about  $0^{\circ}$  ambient temperature. Other circuit elements limit the maximum permissible ambient temperature to about  $40^{\circ}\text{C}$ . Figure 3 shows that at  $60^{\circ}\text{C}$  crystal temperature, the temperature coefficient can be as high as  $3 \times 10^{-7}/^{\circ}\text{C}$ . The approximate warm-up characteristic can be determined from Figure 3. Remember that the crystal temperature increases about  $20^{\circ}\text{C}$  during warmup under normal 115-volt line conditions.

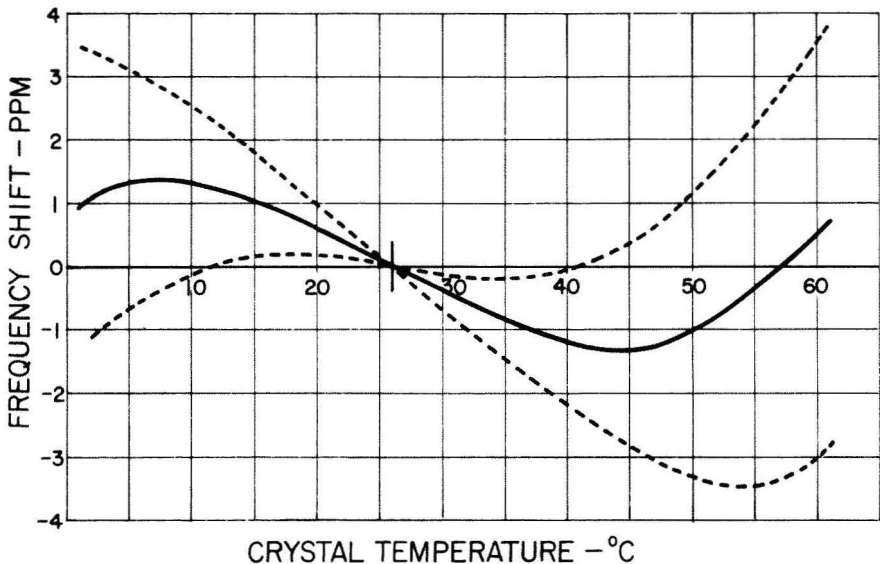

Figure 3. Temperature Characteristic of Crystal.

## TYPE 1213-D UNIT/TIME FREQUENCY CALIBRATOR

Momentary line-voltage changes of up to  $\pm 10\%$  will affect the frequency by less than  $5 \times 10^{-8}$ . Since line-voltage changes affect the power input to the instrument, a line-voltage change will eventually cause a frequency change owing to a change in crystal temperature. A 10% increase in line voltage causes a change in crystal temperature of about  $4^\circ\text{C}$ , affecting frequency as shown in Figure 3.

The effects of function switching and external circuit connections on the standard frequency are less than  $1 \times 10^{-7}$ . In some switch positions, dummy loads are substituted for internal circuits so that the instrument temperature remains nearly constant. In the STANDBY position there is no r-f output, but the heaters are on and dummy loads maintain correct crystal operating temperature.

A buffer stage, V102, is connected between the oscillator and the circuits driven at 10 Mc. This stage provides the power necessary to drive the 1-Mc multivibrator and the harmonic-generating stages. It also acts as a limiter to maintain constant trigger amplitude on the 1-Mc multivibrator under conditions of varying crystal-oscillator output. Since both the plate and grid circuits of V102 are tuned to 10 Mc, neutralization is necessary. C111 and C112 provide the external feedback path for this neutralization. R105 in the grid of V102 isolates rf so that the oscillator output can be checked at test point 1 with a dc vacuum-tube voltmeter, and the buffer output can be measured at test point 2 with an ac vacuum-tube voltmeter without affecting the tuning of the plate circuit. R107, the buffer screen-voltage adjustment, is set to produce correct trigger amplitude at the grids of the 1-Mc multivibrator.

**2.2 MULTIVIBRATORS.** The three frequency-dividing multivibrators are all of similar design, each consisting of a dual-triode tube with its two sections connected as a symmetrical multivibrator. In the absence of an input signal, each multivibrator is set to operate at a free-running frequency less than the locked frequency. This frequency is set by a pair of trimmer capacitors (C119, C122) across the plate-to-grid coupling capacitors in the 1-Mc multivibrator (V103). The timing network for the 1-Mc multivibrator consists of C120, C123, C119, C122, R114, and R115. Crystal diodes D101 and D102 decouple the discharging grids of V103 from the trigger pulse injecting circuit. In each of the three multivibrators, the right-hand plate waveform drives the grids of the succeeding multivibrator, and the left-hand plate is connected to the FUNDAMENTAL FREQUENCY switch through a coupling capacitor.

As the FUNDAMENTAL FREQUENCY switch is set successively from the STANDBY position to 10 Mc, 1 Mc, etc, either the buffer signal or the signal from a multivibrator is connected to the harmonic generator, and, by means of the AUDIO BEAT SIGNAL-TIMING MARKERS switch (S102), to the video amplifier. When the FUNDAMENTAL FREQUENCY switch (S101) is set to a frequency, contacts 201R and 211R switch the power on. The front section of this switch maintains the constant power load and switches the B+ supply to the selected multivibrator.

Contacts 109F and 103F on the front section of S101 produce transients which start the 1-Mc multivibrator.

**2.3 HARMONIC GENERATOR AND MIXER CIRCUIT.** When the AUDIO BEAT SIGNAL-TIMING MARKERS switch is in the AUDIO BEAT SIGNAL position, plate voltage is supplied to the harmonic generator stage, V107. The buffer or the multivibrator selected by the FUNDAMENTAL FREQUENCY switch is connected to the control grid of the pentode section of V107, and the amplified signal from the network at the plate is applied through a coupling capacitor (C150) to the triode section of V107. When the FUNDAMENTAL FREQUENCY switch is in the 10-Mc position, C148 is grounded, and the plate circuit of V107 is tuned to 10 Mc by L106 and circuit strays. In the 1-Mc position, L105 and L106, with the stray capacitance at the plate of V107, form a tuned circuit resonant at 1 Mc. With the switch in the 100-kc or 10-kc position, V107 uses the full network consisting of R135, L105, and L106 as plate load.

The output from the plate of the pentode section of V107 overdrives the triode section. Pulses of plate current in this triode produce voltage spikes across the harmonic generator, D104. These pulses, which produce the standard-frequency harmonic series, are coupled through C152 to D103, the high-frequency mixer, and to the coaxial connector, J101.

A signal fed into J101 is added to the standard-frequency spectrum across D103 and rectified. The rf voltage is filtered by R143 and C154, and the audio beat frequency appears across R146, the diode load resistor. This audio beat signal is coupled through S102, C156, and R145 to the control grid of the pentode section of V106, the audio amplifier.

**2.4 AUDIO-VIDEO AMPLIFIER.** V106 serves either as an audio amplifier for the beat note from the mixer, or as a video-amplifier-limiter and cathode follower to produce timing markers at the OUTPUT binding post. The AUDIO BEAT SIGNAL-TIMING MARKERS switch, S102, when in the AUDIO BEAT SIGNAL position, connects R148 and R149 as plate and screen resistors, respectively. The switch in this position also connects R151 as the plate load resistor for the triode section of V106, and R155 as its cathode resistor. The two sections of V106 then act as an audio amplifier with a gain of about 80 db. The sensitivity of this amplifier is controlled by R153, the AUDIO GAIN control. The rectified signal voltage at the grid of the triode section of V107 is filtered by R140 and C161 and used to produce the d-c audio gain control voltage for the grid of the triode section of V106.

When V106 is used as a video amplifier to produce standard time intervals (S102 in TIMING MARKERS position), the grid of the pentode section of V106 is connected to the buffer or to a selected multivibrator. S102 connects R150 to increase the screen voltage on the pentode section of V106, and connects R147 as the plate load resistor for the pentode. Contacts on the rear section of S102 place R157 in parallel with R151 to increase the plate voltage on the triode section, connect the cathode section of the triode to the output terminals, and add R154 as an additional cathode load resistance. V106 is then converted to a pentode amplifier and limiter followed by a cathode follower to drive the OUTPUT terminals.

## Section 3

# OPERATING PROCEDURE

**3.1 GENERAL.** To turn the Time/Frequency Calibrator on, simply apply power through the power input connector (refer to paragraph 1.3), and set the FUNDAMENTAL FREQUENCY switch to the desired frequency setting.

The following instructions are in five major sections, representing the four basic output calibrating operations and the standardization procedure using a primary frequency standard, either remote (e.g., WWV signals) or local.

### NOTE

When beginning operation, always move the FUNDAMENTAL FREQUENCY switch to start dividers. For this purpose, any position will do.

### 3.2 CALIBRATION BY A PRIMARY FREQUENCY STANDARD.

**3.2.1 GENERAL.** There are two methods of standardizing the crystal frequency of the Unit Time/Frequency Calibrator. One method, described in paragraph 3.2.2, is calibration by zero beat with WWV transmissions. Auxiliary equipment required are a radio receiver to receive the 5-, 10-, or 15-Mc WWV transmissions and either earphones or an oscilloscope to detect the beat note. The other method, described in paragraph 3.2.3, consists of calibration with a local frequency standard. Equipment required is an oscilloscope with which to view the Lissajous figure produced by the local standard against the Type 1213-D.

#### 3.2.2 CALIBRATION AGAINST WWV.

a. Turn on the Unit Time/Frequency Calibrator and the radio receiver, tuning the latter to a WWV transmission on 5, 10, or 15 Mc. Allow both instruments to warm up for about an hour.

b. Couple the radiation from the RF OUTPUT HARMONIC SERIES connector to the antenna terminals of the radio receiver. Set the FUNDAMENTAL FREQUENCY switch to 1 Mc, the AUDIO BEAT SIGNAL-TIMING MARKERS switch to AUDIO BEAT SIGNAL. Adjust the coupling so that a good, clean, beat note is established. (Refer to NOTE, paragraph 3.1.)

c. Set the FREQUENCY ADJUST control of the Type 1213-D to produce a zero beat as indicated either on the earphones or an oscilloscope.

d. If the FREQUENCY ADJUST control will not permit a zero beat setting, adjust the internal series capacitor (C104), with the panel control

## GENERAL RADIO COMPANY

centered, to produce zero beat. Adjust C104 by reaching through the instrument dust cover, with this cover left on.

**3.2.3 CALIBRATION BY A LOCAL FREQUENCY STANDARD.** The only requirement in the choice of a local standard for calibration is that it be able to produce recognizable Lissajous figures at some setting of the FUNDAMENTAL FREQUENCY switch. The procedure is as follows:

a. After allowing the Type 1213-D about one hour's warmup, feed the output from the OUTPUT binding posts to one set of oscilloscope deflection plates. Set the AUDIO BEAT SIGNAL-TIMING MARKERS switch to the TIMING MARKERS position. (Refer to NOTE, paragraph 3.1.)

b. Adjust the FREQUENCY ADJUST control to obtain a stationary Lissajous figure with a ratio appropriate to the two frequencies.

c. If a stationary pattern cannot be obtained, set the FREQUENCY ADJUST control to center scale and reset C104 as described in paragraph 3.2.2 d above.

**3.3 OSCILLOSCOPE CALIBRATION.** The Type 1213-P1 Differentiator Unit, supplied with the Type 1213-D, produces brief (0.15- $\mu$ sec) pulses, both positive and negative going, which can be used as convenient markers for oscilloscope calibration. The use of this device is optional, because the rapid transitions of the square-wave outputs will also serve as a time index.

The 10-kc (100- $\mu$ sec) square wave from the Type 1213-D has no overshoot nor appreciable ramp-off; it can therefore be used to check an oscilloscope amplifier and to probe low-frequency compensation. (The 100-kc and 10-kc outputs of the Type 1213-D have a rise time of about 0.3  $\mu$ sec.)

Since the trace linearity of most oscilloscopes is about a few percent, the Type 1213-D need not be calibrated against a primary frequency standard for this use. The procedure is as follows:

a. Turn on the oscilloscope and the Type 1213-D.

b. Connect the oscilloscope vertical input to the Type 1213-D OUTPUT terminals.

c. Set the AUDIO BEAT SIGNAL-TIMING MARKERS switch to the TIMING MARKERS position.

d. Set the FUNDAMENTAL FREQUENCY switch to the frequency appropriate to the oscilloscope time base to be calibrated. (Refer to NOTE, paragraph 3.1.)

e. Synchronize the oscilloscope either on its own internal signal or connect its synchronizing terminals to the Type 1213-D OUTPUT terminals.

**3.4 VARIABLE-FREQUENCY-OSCILLATOR CALIBRATION BY TYPE 1213-D INTERNAL MIXER-AMPLIFIER SYSTEM.**

a. Turn on the Type 1213-D and the oscillator, and allow them to warm up. If the precision desired warrants, standardize the Type 1213-D by one of the methods described in paragraph 3.2.

b. Connect the oscillator output to the R-F INPUT TO DETECTOR terminals of the Type 1213-D.



## TYPE 1213-D UNIT/TIME FREQUENCY CALIBRATOR

c. Set the AUDIO BEAT SIGNAL-TIMING MARKERS switch to AUDIO BEAT SIGNAL, and set the FUNDAMENTAL FREQUENCY switch to the desired frequency, depending on the dial frequency increments to be established. (Refer to NOTE, paragraph 3.1.)

d. Plug earphones into the Type 1213-D OUTPUT binding posts. Audible beats will be heard as the oscillator dial is rotated.

e. When checking the oscillator calibration using this technique, observe the following two precautions:

(1) The accuracy of the oscillator dial calibration must be relied upon to identify the harmonic used for dial calibration. For example, in order to establish a calibration point correctly at 1000 Mc, the oscillator calibration must be known to within 0.5 percent in order to determine that the 100th 10-Mc harmonic is being used, rather than the 99th or 101st. The frequency of an uncalibrated oscillator can be set to 1000 Mc if equipment is available for calibration of a 100-Mc oscillator using the 10-Mc harmonics and for beating the 10th harmonic of this oscillator against the 1000-Mc oscillator. In the calibration of 1-Mc points (one-percent increments at 100 Mc), the 100-Mc point can be established by the use of the 10-Mc harmonic spectrum if the oscillator calibration is known to within 10 percent.

(2) Care must also be taken to insure that the beat note being heard is not caused by harmonics of the unknown beating against the standard frequency spectrum generated within the Type 1213-D. For instance, suppose an oscillator is being calibrated in the 50- to 100-Mc region against 10-Mc standard harmonic spectrum lines. It is possible that beat notes will be heard at 50, 55, 60 Mc, etc. The second harmonic of 55 Mc (at 110 Mc), if strong enough, will beat against the 11th 10-Mc harmonic to produce a weak but audible signal. The AUDIO GAIN control has deliberately been made nonlinear so that these weaker, spurious signals can usually be eliminated, and the control should be so adjusted.

**3.5 SETTING FIXED-FREQUENCY OSCILLATORS EXACTLY TO A HARMONIC OF THE TYPE 1213-D.** In the adjustment of fixed-frequency oscillators that are to be tuned to exact zero beat with a harmonic of the Type 1213-D (as, for example, in a-m, f-m, and television transmitters), it is often useful to determine the sense of the signal frequency error. The TOUCH TO DECREASE FREQUENCY button is provided for this purpose. Touching this button lowers the frequency of the crystal oscillator of the Type 1213-D by about 2 parts per million. Thus, if the frequency of the fixed oscillator is slightly above a zero-beat point with an output harmonic of the Type 1213-D, the beat note will increase in frequency if the button is touched. If the frequency of the fixed oscillator is below the zero-beat point, the beat note will decrease in frequency when the button is touched. This method will almost always yield a sensing, but one possibility of false indication should be recognized. If the standard frequency harmonic is above the unknown by exactly one-half  $\Delta f$ , where  $\Delta f$  is the deviation of the touch button, there will be no apparent change in beat. In this case, either the unknown or the Type 1213-D crystal frequency must be moved slightly.

# GENERAL RADIO COMPANY

3.6 CALIBRATION BY MEANS OF THE OUTPUT HARMONIC SERIES OF THE TYPE 1213-D. The spectrum of standard frequency harmonics can be connected to an external detector or receiver for calibration or monitoring purposes through the RF OUTPUT-HARMONIC SERIES connector. For instance, the dial calibration of a radio receiver can be checked as follows:

- a. Turn on the Type 1213-D and the receiver, and allow them to warm up for about an hour.
- b. Loosely couple the output of the Type 1213-D from the RF OUTPUT-HARMONIC SERIES connector to the receiver antenna terminals.
- c. Tune the receiver. The harmonic spectrum of the frequency selected by the FUNDAMENTAL FREQUENCY switch should be heard in the receiver output. (Refer to NOTE, paragraph 3.1.)
- d. It is possible that a low-order harmonic will block the i-f amplifiers of certain high-frequency receivers and lower their sensitivity. Determine whether the intermediate frequency is harmonically related to the fundamental frequency selected for calibration. If so, a high-pass filter with sufficient rejection at the intermediate frequency will be required. If the radio receiver has an automatic volume control, the presence of blocking will be evidenced by a steady AVC voltage reading almost independent of rf tuning.

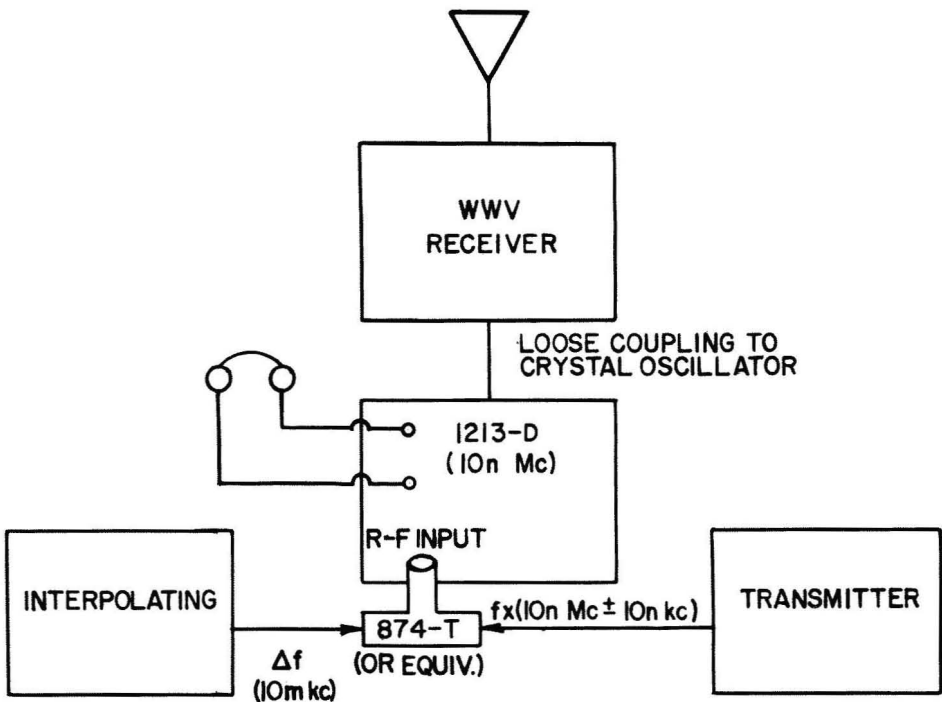

Figure 4. Interpolation Method of Calibration.

## TYPE 1213-D UNIT/TIME FREQUENCY CALIBRATOR

**3.7 INTERPOLATION METHOD OF CALIBRATION.** The 10-kc harmonic series generated by the Type 1213-D permits direct calibration at 10-kc intervals up to 10 Mc. However, with an interpolation oscillator connected as shown in Figure 4, it is possible to calibrate at any multiple of 10 kc up to 1000 Mc. Thus, any broadcast transmitter, for instance, can be standardized directly against WWV on any assigned channel up to 1000 Mc. An oscillator with a frequency range of 10 kc to 5 Mc, with an output of about 1 volt, will interpolate between successive harmonics of the 10-Mc series up to 1000 Mc. The Type 1330-A Bridge Oscillator or the Type 1001-A Standard Signal Generator are recommended. Below 500 Mc an oscillator with a frequency range of 10 kc to 500 kc (such as the Type 1210-C Unit R-C Oscillator) will interpolate between successive harmonics of the 1-Mc series.

Suppose an unknown frequency,  $f_x$ , is spaced  $\Delta f$  kc away from the nearest harmonic of the internally applied harmonic series. If a signal of frequency  $\Delta f$  is simultaneously applied by the interpolation oscillator, the sideband ( $f_x + \Delta f$  or  $f_x - \Delta f$ ) will fall upon this nearest harmonic. If  $\Delta f$  is first standardized as described below,  $f_x$  can then be adjusted to zero-beat with this sideband, just as if  $\Delta f$  were not involved.

The following precautions must be observed in this method of interpolation:

a. The interpolating oscillator must be standardized at  $\Delta f$  kc against the 10-kc harmonic series of the Type 1213-D. Therefore,  $\Delta f$  must be an exact multiple of 10 kc, and must be equal to the frequency difference, in kilocycles, between the unknown ( $f_x$ ) and the nearest harmonic of 1 Mc (or of 10 Mc, when the latter is to be used in the first setting of  $f_x$ ).

b. To avoid spurious beats involving harmonics of the interpolating frequency ( $\Delta f$ ), the interpolating oscillator must be reasonably free of distortion, and its output must be kept below that at which harmonics are generated in the input circuit of the Type 1213-D. To obtain the correct level, set the Type 1213-D to 1 Mc, set the interpolation oscillator to 500 kc, and reduce the oscillator level to the point where no beat note is produced. (Even at this reduced level adequate beats will be produced against the 10-kc series, so that  $\Delta f$  can be standardized as above.)

c. Since the Type 1213-D will respond equally to either sideband, the undesired sideband constitutes the nearest spurious beat involving both  $f_x$  and  $\Delta f$ . This spurious beat is separated from the desired beat by  $2\Delta f$  or by  $(1 \text{ Mc} - 2\Delta f)^*$ , whichever is the smaller, when the 1-Mc harmonic series is used. An independent measurement must be made to assure that  $f_x$  is not in error by this amount.

---

\*In the case of the 10-Mc harmonic series, the nearest spurious beat is separated from the desired beat by  $2\Delta f$  or  $(10\text{Mc} - 2\Delta f)$ , whichever is the smaller.

## Section 4

# CALIBRATION, SERVICE AND MAINTENANCE

**4.1 GENERAL.** The two-year warranty given with every General Radio instrument attests the quality of materials and workmanship in our products. When difficulties do occur, our service engineers will assist in any way possible.

In case of difficulties that cannot be eliminated by the use of these service instructions, please write or phone our Service Department, giving full information of the trouble and of steps taken to remedy it. Be sure to mention the serial and type numbers of the instrument.

Before returning an instrument to General Radio for service, please write to our Service Department or nearest district office (see back cover), requesting a Returned Material Tag. Use of this tag will insure proper handling and identification. For instruments not covered by the warranty, a purchase order should be forwarded to avoid unnecessary delay.

### 4.2 CIRCUIT ADJUSTMENTS.

**4.2.1 GENERAL.** The following is the general procedure for the adjustment of this instrument in our laboratory. It should never be necessary to follow the entire procedure. Only adjustments necessitated by tube or component replacement need be made.

#### NOTE

Remember that the **FUNDAMENTAL FREQUENCY** switch must be moved to start dividers.

### 4.2.2 OSCILLATOR AND BUFFER CIRCUITS.

**4.2.2.1 Adjustment of Quartz-Crystal Oscillator.** The crystal coarse frequency adjustment is C104. Set the oscillator against a primary frequency standard as outlined in paragraph 3.2. Set the panel **FREQUENCY ADJUST** control to 0 (midscale) and adjust C104 (through the dust cover) to zero beat with the primary frequency standard.

**4.2.2.2 10-Mc Doubler Adjustment.** This adjustment should be made when either V101 or V102 is replaced. Connect a dc vacuum-tube voltmeter between TP1 and ground. Adjust C109 for maximum meter reading. The meter should read more than 3 volts.

## TYPE 1213-D UNIT/TIME FREQUENCY CALIBRATOR

**4.2.2.3 10-Mc Buffer Adjustment.** Connect either the vertical amplifier of an oscilloscope of 10-Mc bandwidth or an ac vacuum-tube voltmeter to TP2. With the FUNDAMENTAL FREQUENCY switch set at 10 Mc, adjust L102 for maximum amplitude. The buffer screen potentiometer, R107, should be set fully clockwise. After L102 is adjusted, the voltage reading on the vacuum-tube voltmeter should not be less than 0.4 volt. Reset R107 as described in paragraph 4.2.3.1 g.

### 4.2.3 MULTIVIBRATOR ADJUSTMENTS.

#### 4.2.3.1 1-Mc Multivibrator.

a. Set the AUDIO BEAT SIGNAL-TIMING MARKERS switch to AUDIO BEAT SIGNAL, and set the FUNDAMENTAL FREQUENCY switch to 1 Mc.

b. Connect a pair of headphones to the OUTPUT binding posts.

c. Set R107 fully counterclockwise to remove the 10-Mc trigger pulses from the multivibrator.

d. Connect an rf signal generator, set at 950 kc, to the R-F INPUT TO DETECTOR terminal.

e. Adjust C119 and C122 for a zero beat at 950 kc, while maintaining, as nearly as possible, an equal setting of these capacitors.

f. Connect the oscilloscope probe to the junction of D101, D102, R108 (TP7 in some instruments). Balance C119 and C122 so that the negative spikes have equal time intervals (see waveform, Figure 7). Try to keep the total capacitance constant by increasing one capacitance and decreasing the other. The linearity of the oscilloscope time base should be checked against the 10-Mc timing markers. As the probe capacitance of the oscilloscope has a slight effect, it should be removed after this symmetry adjustment and step e rechecked.

g. Now turn R107 clockwise until the multivibrator just locks and produces a beat note at 1.0 Mc. Note the value of the 10-Mc trigger voltage that corresponds to this just-locked condition. Increase the setting of R107 (turn further clockwise) to produce two to three times this minimum voltage. This voltage should now be between 0.4 and 0.45 volt.

#### 4.2.3.2 100-kc Multivibrator.

a. Disable the 1-Mc multivibrator by clipping TP3 to ground. (Do not remove the tube.)

b. Connect the vertical input of an oscilloscope with a calibrated time base to TP5 on the etched-circuit board or to contact 207R on S101. Use either a low-capacitance probe or a 4.7- $\mu$ f decoupling capacitor. (See waveform, Figure 7.)

c. Observe the plate waveform of V104, using a writing rate of 2 to 4 microseconds per division. Using C128 and C130, set the positive and negative plate excursions to be equal and 5.5 microseconds in duration. Or, using the method described in paragraph 4.2.3.1, set for zero beat against a signal generator at 90 kc while maintaining a symmetrical plate waveform with C128 and C130.

d. Remove the ground from TP3.

#### 4.2.3.3 10-kc Multivibrator.

a. Disable the 100-kc multivibrator by grounding pin 5 or 6 of V104.

b. Connect the oscilloscope probe to TP6 on the etched-circuit board.

## GENERAL RADIO COMPANY

c. Observe the plate waveform of V105 using a writing rate of 20 to 40 microseconds per division. (See waveform, Figure 7.) With C137 and C139, set the positive and negative plate excursions to be equal and 55 microseconds in duration.

d. Remove the ground from pin 5 or 6 of V104.

### 4.2.4 HARMONIC-GENERATOR ADJUSTMENTS.

4.2.4.1 General. L105 and L106 in the harmonic generator are adjusted to produce maximum drive for the harmonic generator. There are two methods of adjustment, described in the following paragraphs.

#### 4.2.4.2 Primary Method.

a. Connect either a dc vacuum-tube voltmeter or a 20,000-ohm-per-volt meter across R146, the 51-kilohm resistor on S102.

b. Set the FUNDAMENTAL FREQUENCY switch to 10 Mc and adjust L106 for maximum meter reading.

c. Set the FUNDAMENTAL FREQUENCY switch to 1 Mc and adjust L105 for maximum meter reading.

4.2.4.3 Secondary Method. The procedure outlined in paragraph 4.2.4.2 may not yield optimum harmonic output. An alternative method is to adjust L105 and L106 for the maximum extent of the harmonic spectrum as follows:

a. Connect an oscillator or signal generator producing a signal of about 1000 Mc to the mixer through the RF INPUT TO DETECTOR connector. Set the FUNDAMENTAL FREQUENCY switch to 10 Mc. Using earphones at the OUTPUT binding posts, adjust the frequency of the external oscillator to obtain an audible beat between a 10-Mc harmonic and the external signal.

b. Adjust L106 for maximum voltage across R146 (refer to paragraph 4.2.4.2 a, b). Then decrease the oscillator output until the beat note is barely audible. Retouch the adjustment of L106 for maximum loudness.

c. Repeat this procedure for the 1-Mc harmonic spectrum, setting the FUNDAMENTAL FREQUENCY switch to 1 Mc and retouching L105 for maximum loudness with an oscillator feeding a signal between 100 and 500 Mc into the mixer.

### 4.3 TROUBLE-SHOOTING PROCEDURE.

4.3.1 GENERAL. The flexibility offered by the switching system of the instrument greatly simplifies the isolation and correction of any failures that may occur. In the event of trouble, first use a radio receiver or oscillator to check the rf input-output system and an oscilloscope to observe the timing marker outputs. Having observed the symptoms of the malfunction, enter Table 1. Match the conditions with one of the vertical columns and refer to the paragraph given at the bottom of the column. A specific tube or component can then be located by reference to the test voltages and resistances, Table 2.

#### NOTE

Remember that the FUNDAMENTAL FREQUENCY switch must be moved to start dividers.

**TABLE 1**  
**TROUBLE-SHOOTING CHART**  
 (refer to paragraph 4.3.1)

Switch setting and equipment connection													
Radio receiver tuned to 5Mc and connected to TOUCH button	A	A	P	P	P	P	P	P	P	P	P	U	
S102 in TIMING MARKERS, rcvr or CRO connected to timing marker output													
S101 at 10 Mc	A	A	A	P	A	P	P	P	P	P	P	U	
S101 at 1 Mc	A	U	U	P	A	A	P	P	U	P	P	U	
S101 at 100 kc	A	U	U	P	A	U	A	P	U	U	P	U	
S101 at 10 kc	A	U	U	P	A	U	U	A	U	U	U	U	
S102 in AUDIO, rcvr or CRO connected to rf output													
S101 at 10 Mc	A	A	A	A	P	P	P	P	P	P	P	U	
S101 at 1-Mc	A	U	U	A	P	A	P	P	U	P	P	U	
S101 at 100 kc	A	U	U	A	P	U	A	P	U	U	P	U	
S101 at 10 kc	A	U	U	A	P	U	U	A	U	U	U	U	
Refer to paragraph	4.3.2	4.3.3	4.3.4	4.3.5	4.3.6	4.3.7	4.3.7	4.3.7	4.3.8	4.3.8	4.3.8	4.3.9	4.3.10
Probable Failure	Pwr Supply	V101	V102	V107	V106	V103	V104	V105	V103	V104	V105	V101	D101

A - Signal absent

P - Signal present

U - Signal present but unstable



**4.3.2 INSTRUMENT DEAD.** Check the power supply and connection. Measure the plate voltage at terminal 15 of PL101. Observe tube heaters for presence of heater potential.

**4.3.3 NO 5-MC OR 10-MC OUTPUT. MULTIVIBRATORS RUN FREE.** When the input signal to a multivibrator is lost, the multivibrator "runs free", and appears to be low in frequency by about 5 or 10 percent. Therefore, when the oscillator (V101) or the buffer (V102) fails, there will still be an output signal from the three multivibrators, but not on the correct frequency. Under these conditions, the output frequency or timing markers will lack stability. When there is no output at 5 Mc from the TOUCH TO DECREASE FREQUENCY button to a radio receiver antenna terminal, and no output from the 10-Mc buffer, the trouble must lie in the oscillator tube or its circuit components. Check the voltages around V101 against those given in Table 2, and check V101.

**4.3.4 5-MC OUTPUT PRESENT BUT NO 10-MC SIGNALS. MULTIVIBRATORS RUN FREE.** When a radio receiver or oscilloscope indicates the presence of a 5-Mc signal at the TOUCH TO DECREASE FREQUENCY button, but there is no 10-Mc signal from either the mixer or video output terminals, check the buffer stage, V102, and check the test voltages against those given in Table 2.

**4.3.5 NO OUTPUT AT RF TERMINALS. OUTPUT FROM TIMING MARKER TERMINALS PRESENT.** When an oscilloscope indicates output from the timing marker terminals but there is no signal present at the RF OUTPUT HARMONIC SERIES connector with the AUDIO BEAT SIGNAL-TIMING MARKERS switch in the AUDIO BEAT SIGNAL position, check the voltages in the harmonic-generator circuit, V107 and its components, against those given in Table 2.

**4.3.6 NO OUTPUT FROM TIMING MARKER TERMINALS. OUTPUT AT RF TERMINALS.** When an oscilloscope or radio receiver connected to the RF OUTPUT HARMONIC SERIES connector indicates the presence of radio frequency, but no signal can be obtained from earphones or from oscilloscope terminals, check the voltages of V106 and its components against those given in Table 2.

**4.3.7 ONE MULTIVIBRATOR OUTPUT (1 MC - 10 KC) MISSING IN BOTH AUDIO AND TIMING MARKER POSITIONS; ONE OR MORE MULTIVIBRATORS UNSTABLE.** When a 10-Mc harmonic spectrum and a 10-Mc timing signal both appear, but no output appears at the output terminal in the 1-Mc switch position, check the 1-Mc multivibrator, V103. Note that with the switch in the 100-kc and 10-kc positions there will be an unstable signal of incorrect frequency. Note that this symptom is characteristic of failure of the 1-Mc multivibrator to start when the FUNDAMENTAL FREQUENCY switch is set.

Correct 10-Mc and 1-Mc outputs with a missing 100-kc output and an unstable 10-kc output indicates difficulty in the 100-kc multivibrator unit only. With only the 10-kc output missing, it is necessary to test only V105 and its components.



## TYPE 1213-D UNIT/TIME FREQUENCY CALIBRATOR

**4.3.8 ALL MULTIVIBRATOR OUTPUTS PRESENT BUT ONE OR MORE OF INCORRECT FREQUENCY OR UNSTABLE.** Instability in the 1-Mc multivibrator output will cause the 100-kc and 10-kc units to be unstable also. When all three lower-frequency output signals are unstable, check V103 and adjust C119 and C122 to compensate for the aged tube or changed component responsible. Another possible cause of failure of V103 to synchronize properly is a loss of trigger voltage due to a gradual weakening of the buffer stage, V102.

Instability of the 100-kc and 10-kc units points to a failure of the 100-kc unit to synchronize. Replace V104 or adjust C128 and C130 for correct operation as outlined in paragraph 4.2.3.2.

**4.3.9 LACK OF FREQUENCY STABILITY IN ALL OUTPUT SIGNALS FROM INSTRUMENT.** A general lack of frequency stability throughout the instrument is an indication either of a defective quartz crystal unit or an unusual difficulty in the oscillator tube (V101 or its components). Replace V101, and if the trouble persists, check its associated components and voltages. At this point, if the oscillator is still malfunctioning, it will be necessary to order a replacement crystal from General Radio Company.

**4.3.10 ALL RF AND VIDEO OUTPUTS PRESENT, BUT INSTRUMENT LACKS SENSITIVITY TO INJECTED RF SIGNAL AT RF INPUT TO DETECTOR TERMINAL.** This is an indication of a lack of mixer efficiency. The component most worthy of inspection is D101, the germanium mixer crystal. Replace this component if necessary.

# GENERAL RADIO COMPANY

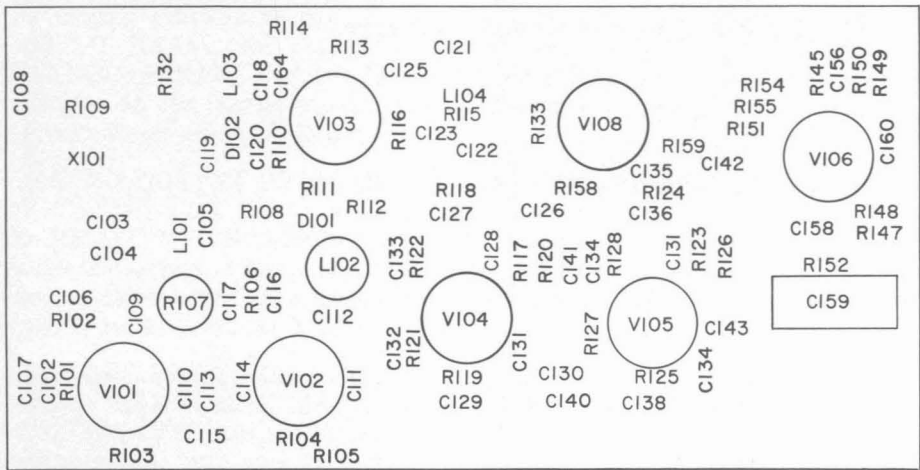
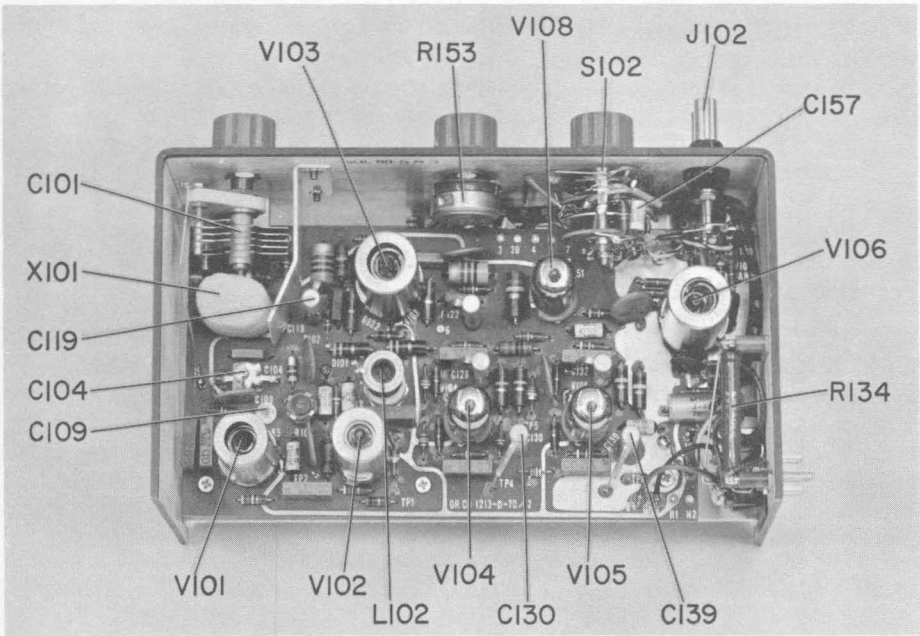

Figure 5.  
Top Interior View and Etched Board Layout.

# TYPE 1213-D UNIT TIME/FREQUENCY CALIBRATOR

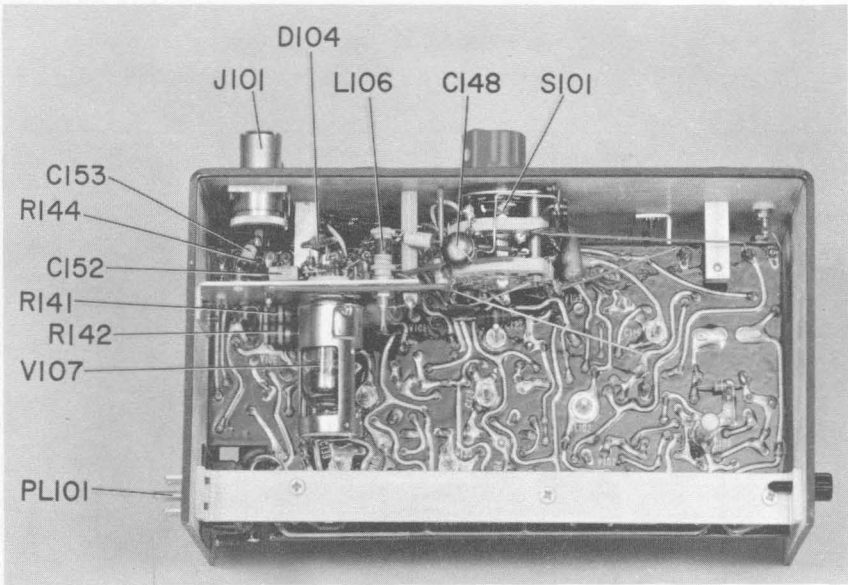
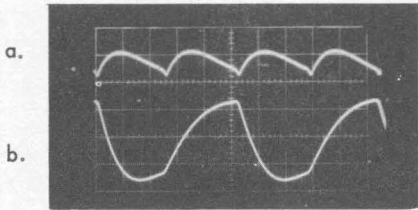
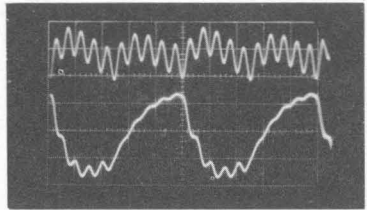

Figure 6.  
Bottom Interior View.



1-Mc Multivibrator - No trigger  
a.  $0.2\mu\text{sec/cm}$ , 5.0 volts/cm. Junction D101, D102  
b.  $0.2\mu\text{sec/cm}$ , 10.0 volts/cm. TP3



1-Mc Multivibrator - Triggered  
a.  $0.2\mu\text{sec/cm}$ , 5.0 volts/cm. Junction D101, D102  
b.  $0.2\mu\text{sec/cm}$ , 10.0 volts/cm.

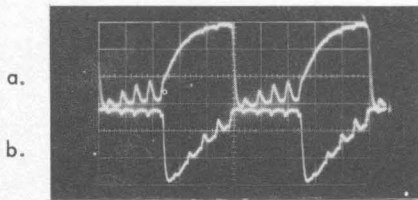

100-kc Multivibrator  
a.  $2\mu\text{sec/cm}$ , 25 volts/cm. TP5  
b.  $2\mu\text{sec/cm}$ , 20 volts/cm. V104 pin 6

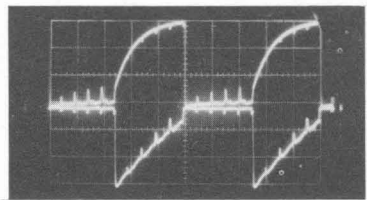

10-kc Multivibrator  
a.  $20\mu\text{sec/cm}$ , 25 volts/cm. TP6  
b.  $20\mu\text{sec/cm}$ , 25 volts/cm. V105 pin 6

Figure 7. Test Waveforms.

(All waveforms taken with 10-megohm,  $2\text{-}\mu\text{f}$  probe.)

# GENERAL RADIO COMPANY

TABLE 2.  
TABLE OF VOLTAGES AND RESISTANCES

TUBE (TYPE)	PIN	VOLTS	RES TO GROUND	TUBE (TYPE)	PIN	VOLTS	RES TO GROUND
V101 (6AK5)	1	-0.8	470 k	V105 (5964)  (Cont)	4	0	
	2	0	0		5	-18	1 M
	3	6.3 ac			6	-18	1 M
	4	0		7	0	0	
	5	115	12 k	V106 (6AN8) S102 at AUDIO BEAT	1	75	100 k
	6	54	32 k		2	0	10 M
	7	0	0		3	3	1.5 k
V102 (6AH6WA)	1	(A)	470 k		4	0	
	2	0	0		5	6.3 ac	
	3	6.3 ac		6	85	1.1 M	
	4	0		7	14	6.8 M	
	5	260	22 k	8	-0.6	1 M	
	6	(B)	(B)	9	0	0	
	7	0	0	V106 (6AN8) S102 at TIMING MARKER	1	195	19 k
V103 (6922)	1	120	16 k		2	0	10 M
	2	32	5.5 k (C)		3	15	3 k
	3	42	75 k (D)		4	0	
	4	0	3.3 k		5	6.3 ac	
	5	6.3 ac		6	230	9k	
	6	120	16 k	7	120	95 k	
	7	32	5.5 k (C)	8	-11	1 M	
8	42	75 k (D)	9	0	0		
V104 (5964)	1	50	45 k	V107 (6U8)	1	110	20 k (C)
	2	50	45 k		2	-13	1 M
	3	6.3 ac			3	110	20 k
	4	0			4	0	
	5	-12	300 k		5	6.3 ac	
	6	-12	300 k		6	90	20 k
	7	0	0		7	0	0
V105 (5964)	1	38	150 k		8	0	0
	2	38	150 k		9	0	370 k
	3	6.3 ac		V108 (5651)	5	82	30 k

NOTES:

(A) Depends on V101 characteristic; must be greater than 3 v dc.  
 (B) Depends on amount of sync signal required; approx 60 v dc, 65 k.  
 (C) Forward (D) Back  
 Except where otherwise noted, S102 is at AUDIO BEAT SIGNAL, AUDIO GAIN fully

clockwise, FUNDAMENTAL FREQUENCY at 10 kc.  
 All voltages are dc unless otherwise noted.  
 All resistances measured with B+ and B- shorted together from point indicated to ground.  
 All dc voltages measured with VTVM, with 1- megohm isolation.

# TYPE 1213-D UNIT TIME/FREQUENCY CALIBRATOR

## PARTS LIST

REF DES	PART NO. (NOTE A)				REF DES	PART NO. (NOTE A)			
<b>RESISTORS (NOTE B)</b>					<b>CAPACITORS (NOTE C)</b>				
R101	56k	± 5%	1/2w	REC-20BF	R157	22k	± 5%	1/2w	REC-20BF
R102	15k	± 5%	1/2w	REC-20BF	R158	11k	± 5%	1/2w	REC-20BF
R103	470k	± 5%	1/2w	REC-20BF	R159	47k	± 5%	1/2w	REC-20BF
R104	470k	± 5%	1/2w	REC-20BF	<b>CAPACITORS (NOTE C)</b>				
R105	1M	± 5%	1/2w	REC-20BF	C101				368-416
R106	150k	± 5%	1/2w	REC-20BF	C102	100	± 1%	500dcwv	COM-5F
R107	100k	±20%		POSC-22	C103	43	± 5%	500dcwv	COM-15D
R108	3.3k	± 5%	1 w	REC-30BF	C104	1.8-13			1213-D-42
R109	12k	± 5%	2 w	REC-41BF	C105	0.01µf		1000dcwv	COC-63
R110	5.1k	± 5%	1 w	REC-30BF	C106	0.01µf		1000dcwv	COC-63
R111	100	± 5%	1/2w	REC-20BF	C107	178	± 1%	500dcwv	COM-5F
R112	3.3k	± 5%	1 w	REC-30BF	C108	15	±10%	500dcwv	COC-21 N750
R113	100	± 5%	1/2w	REC-20BF	C109	1-12			COT-26-2
R114	68k	± 5%	1/2w	REC-20BF	C110	15	±10%	500dcwv	COC-21NPO
R115	68k	± 5%	1/2w	REC-20BF	C111	6.8	±10%	500dcwv	COC-1
R116	5.1k	± 5%	1 w	REC-30BF	C112	0.0022µf	± 5%	500dcwv	COM-5D
R117	22k	± 5%	1 w	REC-30BF	C113	0.01		1000dcwv	COC-63
R118	270k	± 5%	1/2w	REC-20BF	C114	22	±10%	500dcwv	COC-21NPO
R119	270k	± 5%	1/2w	REC-20BF	C115	0.001µf	±10%	500dcwv	COM-5B
R120	22k	± 5%	1 w	REC-30BF	C116	4.7	±10%	500dcwv	COC-21NPO
R121	100	± 5%	1/2w	REC-20BF	C117	47	±10%	500dcwv	COC-21 N750
R122	100	± 5%	1/2w	REC-20BF	C118	24	± 5%	500dcwv	COC-21 N750
R123	100k	± 5%	1 w	REC-30BF	C119	1-12			COT-26-2
R124	910k	± 5%	1/2w	REC-20BF	C120	18	±10%	500dcwv	COM-15B
R125	910k	± 5%	1/2w	REC-20BF	C121	0.01µf		1000dcwv	COC-63
R126	100k	± 5%	1 w	REC-30BF	C122	1-12			COT-26-2
R127	100	± 5%	1/2w	REC-20BF	C123	18	±10%	500dcwv	COM-15B
R128	100	± 5%	1/2w	REC-20BF	C124	24	± 5%	500dcwv	COC-21 N750
R129	120k	± 5%	1 w	REC-30BF	C125	100	±10%	500dcwv	COM-15B
R130	33k	± 5%	1 w	REC-30BF	C126	10	±10%	500dcwv	COC-21 N750
R131	6.2k	± 5%	10w	REPO-44	C127	33	± 5%	500dcwv	COM-5D
R132	10k	± 5%	1/2w	REC-20BF	C128	1-12			COT-26-2
R133	51k	± 5%	2 w	REC-41BF	C129	33	± 5%	500dcwv	COM-5D
R134	4.3k	± 5%	10w	REPO-44	C130	1-12			COT-26-2
R135	2.7k	± 5%	1/2w	REC-20BF	C131	2.2	±10%	500dcwv	COC-1
R136	100k	± 5%	1/2w	REC-20BF	C132	3.9	± 5%	500dcwv	COC-1
R137	10k	± 5%	1/2w	REC-20BF	C133	2.7	± 5%	500dcwv	COC-1
R138	51	± 5%	1/2w	REC-20BF	C134	0.01µf		500dcwv	COC-63
R139	1M	± 5%	1/2w	REC-20BF	C135	47	±10%	500dcwv	COC-21 N750
R140	120k	± 5%	1/2w	REC-20BF	C136	100	± 2%	500dcwv	COM-5E
R141	36k	± 5%	2 w	REC-41BF	C137	1-12			COT-26-2
R142	36k	± 5%	2 w	REC-41BF	C138	100	± 2%	500dcwv	COM-5E
R143	10k	± 5%	1/2w	REC-20BF	C139	1-12			COT-26-2
R144	100k	± 5%	1/2w	REC-20BF	C140	3.3	±10%	500dcwv	COC-1
R145	1M	± 5%	1/2w	REC-20BF	C141	3.3	±10%	500dcwv	COC-1
R146	51k	± 5%	1/2w	REC-20BF	C142	0.01µf		1000dcwv	COC-63
R147	8.2k	±10%	1 w	REC-30BF	C143	15	±10%	500dcwv	COC-21NPO
R148	1.1M	± 5%	1/2w	REC-20BF	C144	6.8	±10%	500dcwv	COC-1N750
R149	6.8M	± 5%	1/2w	REC-20BF	C145	39	± 5%	500dcwv	COC-21 N750
R150	91k	± 5%	1/2w	REC-20BF					
R151	100k	± 5%	1/2w	REC-20BF					
R152	10M	± 5%	1/2w	REC-20BF					
R153	250k	±10%		POSC-12					
R154	1.5k	± 5%	1/2w	REC-20BF					
R155	1.5k	± 5%	1/2w	REC-20BF					
R156	1M	± 5%	1/2w	REC-20BF					

# GENERAL RADIO COMPANY

## PARTS LIST (Cont)

REF DES	PART NO. (NOTE A)			REF DES	PART NO. (NOTE A)					
<b>CAPACITORS (NOTE C)</b>				<b>SWITCHES</b>						
C147	0.01μf		1000dcwv	COC-63	S101	SWRW-196				
C148	0.01μf		1000dcwv	COC-63	S102	SWRW-197				
C149	0.1μf	±10%	400dcwv	COW-25	<b>TUBES</b>					
C150	100	±10%	500dcwv	COC-21NM	V101	6AK5				
C151	0.001μf		500dcwv	COC-3	V102	6AH6-WA				
C152	47	±10%	500dcwv	COC-21 N750	V103	6922				
C153	10	±10%	500dcwv	COC-21NPO	V104	5964				
C154	0.0047μf	±10%	1000dcwv	COC-62	V105	5964				
C155	24	± 5%	500dcwv	COC-21 N750	V106	6AN8				
C156	0.01μf		1000dcwv	COC-63	V107	6U8				
C157	330	±10%	500dcwv	COC-21	V108	5651				
C158	0.0047μf		500dcwv	COC-62	<b>QUARTZ CRYSTAL</b>					
C159	0.1μf	±10%	400dcwv	COW-25	X101	1213-D-44				
C160	0.0047μf		500dcwv	COC-62	<b>NOTES</b>					
C161	0.0047μf		500dcwv	COC-62	<p>(A) Type designations for resistors and capacitors are as follows:</p> <p>COC - Capacitor, ceramic            COM - Capacitor, mica            COT - Capacitor, trimmer            COW - Capacitor, wax            POSC - Potentiometer, composition            REC - Resistor, composition            REPO - Resistor, power</p> <p>(B) All resistances are in ohms, except as otherwise indicated by k (kilohms) or M (megohms).</p> <p>(C) All capacitances are in μf, except as otherwise indicated by μf.</p>					
C162	0.01μf		1000dcwv	COC-63						
C163	0.047μf	±10%	200dcwv	COW-16						
C164	0.0047μf		1000dcwv	COC-62						
<b>INDUCTORS</b>										
L101	10μh	±10%	CHM-1							
L102			1213-201							
L103	560μh	±10%	CHM-6							
L104	560μh	±10%	CHM-6							
L105	515-830μh		CHA-59-13							
L106	14.5-22.5μh		CHA-59-6							
<b>DIODES</b>										
D101	1N191									
D102	1N191									
D103	1N34A									
D104	1N455A									



FUNDAMENTAL FREQUENCY  
 MOVE SWITCH TO START DIVIDER  
 10MC    100KC  
 IMC    10KC  
 STANDBY

R-F INPUT TO DETECTOR  
 R-F OUTPUT HARMONIC SERIES  
 J101 ENGRAVING

AUDIO BEAT SIGNAL  
 TIMING MARKERS  
 S102 ENGRAVING



NOTES:  
 RESISTORS 1/2 WATT, UNLESS OTHERWISE SPECIFIED.  
 RESISTANCE IN OHMS, UNLESS OTHERWISE SPECIFIED.  
 K = 1000 OHMS    M = 1 MEGOHM

CAPACITANCE VALUES ONE AND OVER IN MICRO MICROFARADS, LESS THAN ONE IN MICROFARADS, UNLESS OTHERWISE SPECIFIED

○ KNOB CONTROL  
 ⊗ SCREWDRIIVER ADJUSTMENT

File Courtesy of GRWiki.org  
 Figure 8. Schematic Diagram of the Type 1213-D Unit Time/Frequency Calibrator.

## TYPE 874 ACCESSORIES

ADAPTORS			CABLE (DOUBLE-SHIELDED)			
Type	Contains Type 874 Connector and	Fits	Type	Z	Attenuation/100 ft	
874-QBJ	BNC Jack	BNC Plug	874-A2	50Ω ±5%	2.6 db at 100 Mc	
874-QBP	BNC Plug	BNC Jack	874-A3	50Ω ±5%	5.3 db at 100 Mc	
874-QCJ	C Jack	C Plug	<b>CONNECTORS</b>			
874-QCP	C Plug	C Jack	<b>CABLE CONNECTORS</b>			
874-QHJ	HN Jack	HN Plug	<b>TYPE</b>		<b>FOR CABLE TYPE</b>	
874-QHP	HN Plug	HN Jack	874-C		874-A2	
874-QLJ	LC Jack	LC Plug	874-C8		RG8/U	
874-QLP	LC Plug	LC Jack	874-C9		RG9/U, RG116/U	
874-QLTJ	LT Jack	LT Plug	874-C58		874-A3, RG29/U, RG55/U, RG58/U, RG58A/U	
874-QLTP	LT Plug	LT Jack			RG59/U, RG62/U	
874-QNJ	N Jack	N Plug	874-C62			
874-QNP	N Plug	N Jack	<b>PANEL CONNECTORS</b>			
874-QSCJ	SC Jack	SC Plug	(-P -HEX NUT MTG, -PB -FLANGE MTG)			
874-QSCP	SC Plug	SC Jack	874-P, -PB		874-A2	
874-QTNJ	TNC Jack	TNC Plug	874-P8, -PB8		RG8/U	
874-QTNP	TNC Plug	TNC Jack	874-P9, -PB9		RG9/U, RG116/U	
874-QUJ	UHF Jack	UHF Plug	874-P58, -PB58		874-A3, RG29/U, RG55/U, RG58/U, RG58A/U	
874-QUP	UHF Plug	UHF Jack	874-P62, -PB62		RG59/U, RG62/U	
874-QUIA		7/8" 50Ω UHF rigid air line	<b>PATCH CORDS (3 FT)</b>			
874-QU2		1-5/8" 50Ω UHF rigid air line	TYPE	CONNECTOR	CABLE	CONNECTOR
874-QU3A		3-1/8" 50Ω UHF rigid air line	874-R20	874-C	874-A2	874-C
874-QV2A		1-5/8" 51.5Ω VHF rigid air line	874-R22	874-C58	874-A3	874-C58
874-QV3		3-1/8" 51.5Ω VHF rigid air line	874-R33	874-C58	Single-shielded	274-P
874-Q2	274 Jack	274 Plug	874-R34	874-C58	Single-shielded	274-NK
874-Q6	Pin & Sleeve	274-NF				
874-Q7	774 Jack	774 Plug				
<b>MISCELLANEOUS</b>						
TYPE 874-		TYPE 874-		TYPE 874-		
BM	300Ω Balanced Termination	LK	Constant-Z Adjust. Line	UB-P3	300Ω Balun Terminal Pad	
D	Adjustable Stubs	LR	Radiating Line	VC	Variable Capacitor	
EL	90° Ell	LT	Trombone-Constant-Z Line	W100	100Ω Coax. Standard	
F	Low-Pass Filter			W200	200Ω Coax. Standard	
FR	Rejection Filter	M	Component Mount	WM	50Ω Termination	
G	Fixed Attenuator	MA	Adjustable Coupling Probe	WN	Short-Circuit Termination	
GA	Adjustable Attenuator			WO	Open-Circuit Termination	
JR	Rotary Joint	MB	Coupling Probe	X	Insertion Unit	
K	Coupling Capacitor	T	Tee	XL	Series Inductor	
L	Air Line	UB	Balun	Y	Cliplock	
LA	Adjustable Line	UB-P2	200Ω Terminal Unit	Z	Stand	

The above is a partial listing. For complete list and specifications, refer to the General Radio Catalog.



# GENERAL RADIO COMPANY

WEST CONCORD, MASSACHUSETTS

EMerson 9-4400

CLearwater 9-8900

## DISTRICT OFFICES

### NEW YORK

Broad Ave. at Linden, Ridgefield, N. J.  
Telephone N.Y. WOrth 4-2722  
N.J. WHitney 3-3140

### PHILADELPHIA

1150 York Rd., Abington, Penna.  
Telephone HANcock 4-7419

### WASHINGTON

8055 13th St., Silver Spring, Md.  
Telephone JUniper 5-1088

### CHICAGO

6605 West North Ave., Oak Park, Ill.  
Telephone VillAge 8-9400

### LOS ANGELES

1000 N. Seward St., Los Angeles 38,  
Calif.  
Telephone HOLlywood 9-6201

### SAN FRANCISCO

1186 Los Altos Ave., Los Altos, Calif.  
Telephone WHitecliff 8-8233

### CANADA

99 Floral Pkwy., Toronto 15, Ont.  
Telephone CHerry 6-2171

## REPAIR SERVICES

### EAST COAST

General Radio Company  
Service Department  
22 Baker Ave., W. Concord, Mass.  
Telephone EMerson 9-4400

### NEW YORK

General Radio Company  
Service Department  
Broad Ave. at Linden, Ridgefield, N. J.  
Telephone N.Y. WOrth 4-2722  
N.J. WHitney 3-3140

### MIDWEST

General Radio Company  
Service Department  
6605 West North Ave., Oak Park, Ill.  
Telephone VillAge 8-9400

### WEST COAST

Western Instrument Co.  
826 N. Victory Blvd., Burbank, Calif.  
Telephone VICToria 9-3013

### CANADA

Bayly Engineering, Ltd.  
First Street, Ajax, Ontario  
Telephone Toronto EMpire 2-3741

Printed in USA

